

MODIFICATION AND EVALUATION OF RAW BANANA PEELING MACHINE

BY

MORADIYA RAHUL M.

B.Tech. (Agricultural Engineering)

(REG. NO. 04-2031-2012)

**COLLEGE OF FOOD PROCESSING TECHNOLOGY AND BIO-ENERGY
ANAND AGRICULTURAL UNIVERSITY
ANAND-388 110**

2014

**MODIFICATION AND EVALUATION OF RAW
BANANA PEELING MACHINE**

**A
THESIS**

**SUBMITTED TO THE
ANAND AGRICULTURAL UNIVERSITY
IN PARTIAL FULFILMENT OF THE REQUIREMENTS
FOR THE AWARD OF THE DEGREE
OF**

MASTER OF TECHNOLOGY

**IN
FOOD PROCESSING TECHNOLOGY**

BY

MORADIYA RAHUL M.

B.Tech. (Agricultural Engineering)

(REG. NO. 04-2031-2012)

**COLLEGE OF FOOD PROCESSING TECHNOLOGY AND BIO-ENERGY
ANAND AGRICULTURAL UNIVERSITY
ANAND-388 110**

2014

MODIFICATION AND EVALUATION OF RAW BANANA PEELING MACHINE

Name of the Student

Name of Major Guide

Moradiya Rahul M.

Dr. R. F. Sutar

**College of Food Processing Technology and Bio-Energy,
Anand Agricultural University, Anand-388 110**

ABSTRACT

Banana peeling is the primary and most important operation in banana processing. Manual peeling is relatively slow operation and involves substantial labor when a large number of peeled bananas are desired, so power operated banana peeling machine was designed and developed, suitable for small scale processing unit.

Robusta variety of banana was selected for the study. Some physical properties of unripe banana fruit were determined. The properties like weight, effective length, diameter of fruit (with peel and without peel), of banana were determined.

Banana peeling machine is modified and evaluated based on physical properties of banana fruit. The entire machine was divided into four units namely frame, conveying unit, peeling unit and power transmission unit. The conveying unit consisted of main components like belts, pulleys, belts support plate, pusher, guiding channel, slitting unit and pulp collection channel. The second important unit of modified banana peeling machine was peeling unit, consisting of telescopic channel, roller, pins, spring and separating unit. The power transmission unit consisted of electric motor and variable frequency drive.

The average respective values of weight, effective length of fruit were 93.64 g and 133.30 mm respectively for *Robusta*. The average diameter of banana with peel at top, middle and bottom of *Robusta* variety was found to be 31.60, 33.01 and 30.20 mm respectively. The average thickness of peel at top,

middle and bottom of *Robusta* variety was 3.72, 3.97 and 4.02 mm respectively. The average diameter of banana without peel at top, middle and bottom of *Robusta* variety was 24.16, 25.06 and 22.65 mm respectively. Pulley rpm were to be measured 27, 32, 37, 42, 48, 54, 59, 64, 70 and 75 respectively, for VFD reading from 1.3 to 2.2

Banana peeling machine was conceptualized, designed and fabricated by combination of gripping, slitting and scrapping mechanisms. The maximum and minimum feed rate of banana peeling machine was observed to be 118.07 kg/hr at 75 rpm and 78.19 kg/hr at 27 rpm respectively. The maximum and minimum effective capacity of banana peeling machine was observed to be 84.55 kg/hr at 64 rpm and 66.78 kg/hr at 54 rpm respectively. The peeling efficiency of machine increased as rpm of horizontal pulley increased up to 32 rpm. However, as the rpm was increased further peeling efficiency of machine decreased. The peeling efficiency of the machine was found to be minimum 75 % at 75 rpm and maximum 96 % at 32 rpm. The maximum and minimum damage banana peeling machine observed 25 % at 75 rpm and 4 % at 32 rpm respectively. Average power required to operate the machine under no load condition was observed to be 1.43 kW while average power required for operating the peeling machine was 2.06 kW under full load condition.

Keywords: Banana, Feed rate, Peeling, Peeled efficiency, Operating capacity, Damage percentage.

ACKNOWLEDGEMENT

*This investigation is dedicated to the **almighty god** who is everywhere. I also have heartiest gratitude and reverence to god.*

*God has created his mirror image in a guru and parents to live all together on the earth. I have pleasure and privilege to express these feelings to my advisor **Dr. R. F. Sutar**, Professor and Head, College of Food Processing Technology and Bio-energy, Agricultural University, Anand. His enthusiasm and optimism made this experience both rewarding and enjoyable. His feedback and editorial comments were also invaluable for the writing of this thesis. Without his inspiration, valuable guidance, blessings and facilities provided during the tenure of study it would have not been possible to reach at this stage.*

*Perhaps the best work I did in the course of this thesis was to choose an incredible committee. I am obliged to the Co-guide of advisory committee **Dr. S. S. Kapdi**, Professor and Head, Department of Bio-energy, College of Food Processing Technology and Bio-energy, Agricultural University, Anand and member of advisory committee **Er. R. Gupta** Assistant Professor, Department of Post Harvest Engineering and Technology, College of Food Processing Technology and Bio-energy, Agricultural University, Anand and **Er. M. Makwana**, Assistant Professor, Department of Food Engineering, College of Food Processing Technology and Bio-energy, Agricultural University, Anand for their valuable & timely guidance & suggestions during the course of studies and keenly reviewing the manuscript of the thesis.*

*I would express my thanks to **Dr. D. C. Joshi**, Principal and Dean, College of Food Processing Technology and Bio-energy, Agricultural University, Anand for providing facilities for research work. I wish to express my deep sense of gratitude with due regards to **Dr. S. H. Akbari**, Associate Professor, college of Food Processing Technology and Bio-energy, AAU, Anand, I shall be deeply indebted to him for his invaluable suggestions, encouragement and valuable guidance. He has supported me to solve literally every problem in my period of study.*

*I express my sincere thanks to **Mr. Arvind Parmar**, workshop incharge, College of Food Processing Technology and Bio-energy, Agricultural University, Anand to make project task, in completion. also I'm very thankful to co-workers of workshop*

Nileshbhai, Kureshbhai, Pintubhai, Ravajikaka, Maheshbhai, and Padhiyarbhai for their cooperation by various ways during my research

*Many minds and hands have worked together for fulfilment of this humble presentation. I would like to thank **Mr. Kedar Patil** (Sr. Research Fellow), **Mr. Hitesh** (lab technician), **Mr. Rekit, Mrs. Swati** (Sr. Research Assistant), **Ms. Hetal Bhatt** (Sr. Research Fellow), **Mr. Prafful Kamble** (Sr. Research Fellow), **Mr. Anil Pandey** (Research Associate) for showing their interest in my work and helping in analytical works.*

I wish to express my warm and sincere thanks to staff of College of Food Processing Technology, AAU, Anand for their ever willing co-operation and helpful suggestions during the course of the study.

*I wish to convey my special thanks to my friends, **Anilkumar, Anilkumar S.I, Piyush, Ajay, Romin, Mehul, Chandan, Gayatri, Srishti, Neel, Savan, Ashish**, because of their moral supports, everlasting love and encouragement, which made this dream a reality, as well as all my juniors for their co-operation and excellent company throughout my post graduate curriculum.*

*Last but not the least I express my profound respect and gratitude to my parents **Shri Manjibhai Moradiya and Smt. Sardaben Moradiya**. Brother **Mr. Mohit Moradiya** and all my family members for their ever-lasting love, encouragement, financial support, obstinate sacrifices, sincere prayers, expectations and blessings which have always been vital source of inspiration in my life and made this study possible*

Date:

Place: Anand

*(**Moradiya Rahul M.**)*

PARTICULARS

	Abstract	I
	Acknowledgement	iii
	List of Tables	vii
	List of Figures	ix
	List of Abbreviation	xii
I	Introduction	1
II	Review of Literature	5
	2.1 Banana	5
	2.1.1 Status of banana	5
	2.1.2 Health benefits and nutritional value of banana fruit	5
	2.1.3 Physical and mechanical properties	6
	2.2 Peeling Mechanism	7
III	Materials and Methods	19
	3.1 Measurement of Physical Properties of Banana Fruit	19
	3.1.1 Raw materials	19
	3.1.2 Dimensions of banana fruit	19
	3.1.3 Pulp to peel ratio	23
	3.2 Design Concept of Banana Peeling Machine	20
	3.3 Component of Banana Peeling Machine	22
	3.3.1 Frame	22
	3.3.2 Conveying unit	22
	3.3.2.1 <i>Belt and pulleys</i>	22
	3.3.2.2 <i>Belt support plate</i>	22
	3.3.2.3 <i>Pusher</i>	22
	3.3.2.4 <i>Guiding channel</i>	22
	3.3.2.5 <i>Slitting unit</i>	23
	3.3.2.6 <i>Pulp collection channel</i>	23
	3.3.3 Peeling unit	23
	3.3.3.1 <i>Telescopic Channel</i>	23
	3.3.3.2 <i>Rollers and pins</i>	23
	3.3.3.3 <i>Spring</i>	23
	3.3.3.4 <i>Separating unit</i>	24
	3.3.4 Power transmission unit	25
	3.3.4.1 Electric motor	25
	3.3.4.2 Vertical conveying pulley	25

3.4 Laboratory Equipment for Testing of Banana Peeling Machine	25
3.4.1 Variable frequency drive (VFD)	25
3.4.2 Power measuring instruments	27
3.4.3 Speed measuring instrument	28
3.4.4 Time measuring instrument	29
3.4.5 Weight measuring instrument	29
3.5 Performance evaluation of banana peeling machine	29
3.5.1 Capacity of machine	29
3.5.2 Damage percentage	30
3.5.3 Peeling efficiency	30
3.5.4 Effective capacity	30
3.5.5 Feed rate	31
IV Results and Discussion	32
4.1 Physical Properties of Banana	32
4.1.1 Weight	32
4.1.2 Effective length	32
4.1.3 Diameter	33
4.1.4 Thickness of peel	33
4.1.5 Pulp to peel ratio	36
4.2 Modified Banana Peeling Machine	36
4.3 Design and Its Components of Banana Peeling Machine	41
4.3.1 Frame and its components	41
4.3.2 Design of conveying unit and its components	42
4.3.2.1 Belts and pulleys	42
4.3.2.2 Belts support plate	43
4.3.2.3 Pusher	44
4.3.2.4 Guiding channel	45
4.3.2.5 Slitting unit	45
4.3.2.6 Pulp collection channel	46
4.3.3 Design of peeling unit and its components	46
4.3.3.1 Telescopic Channel	46
4.3.3.2 Rollers and pins	46
4.3.3.3 Spring	47
4.3.3.4 Separating unit	47
4.3.4 Design of power transmission unit and its components	49

4.4	Performance Evaluation of Banana Peeling Machine	54
4.4.1	Percentage of peeled fruits	54
4.4.2	Percentage of damage fruits	54
4.4.3	Capacity and feed rate of banana peeling machine	55
4.4.4	Effect of rpm with respect to VFD reading	55
4.4.5	Effect of rpm of pulley on peeling	55
4.4.6	Power consumption	59
V	Summary and Conclusions	60
VI	References	63
	Annexures	68

LIST OF TABLES

Table No	Caption	Page No.
2.1	Nutritional value of raw banana	6
2.2	Physical and mechanical properties of raw banana	7
4.1	Physical properties of raw banana fruit	34
4.2	Performance evaluation of banana peeling machine at VFD reading 1.3 - 1.7	56
4.3	Performance evaluation of banana peeling machine at VFD reading 1.8 – 2.2	57

LIST OF FIGURES

Figure No.	Caption	Page No.
2.1	Side elevation of pear peeler machine	8
2.2	Top view of fruit peeling machine	9
2.3	(a) Vertical central section of the rotary cutter (b) Cutting blade use in rotary cutter	10
2.4	Apparatus for feeding and guiding of banana to peeling unit	11
2.5	(a) Banana peeling machine (b) mechanism for peeling	12
2.6	Passageway of fruit with spring	13
2.7	Rotary blade with a cutting edge	14
2.8	Angled view of fruit peeling machine	14
2.9	Top view of a modified tool containing a retractable knife blade	15
2.10	Perspective view that shows peeling of green banana by hand	15
2.11	(a) Side view of plantain peeler (b) Adjustable cutting blade	16
2.12	Isometric view of banana peeling machine	18
3.1	Digital caliper	20
3.2	Banana peeling machine	21
3.3	Variable frequency drive (VFD)	26
3.4	Wattmeter	27
3.5	Ammeter	28
3.6	Digital tachometer	28
4.1	Isometric view of banana peeling machine	38
4.2	Side view of banana peeling machine	39
4.3	Top view of banana peeling machine	40
4.4	Existing frame	41
4.5	Isometric view horizontal pulley and shaft assembly	43
4.6	Different angle view of pusher	44
4.7	Isometric view of peeling unit	48
4.8	Side view of slitting unit	49

4.9	Top view of slitting unit	50
4.10	Sample preparation for peeling	51
4.11	After peeling banana fruit	51
4.12	Slitting operation	52
4.13	Peeling operation	52
4.14	Pusher with belts	53
4.15	After peeling flesh of fruit transferred by pusher	53
4.16	Effect of rpm of pulley on peeling efficiency	58
4.17	Effect of rpm of pulley on damage (%)	58
4.18	Effect on effective capacity and feed rate with respect to rpm of pulley	59

LIST OF ABBREVIATIONS AND SYMBOLS

Anon.	Anonymous
A	Ampere
°B _x	Degree brix
°C	Degree Celsius
cm	Centimeter
db	Dry basis
etc.	<i>et cetera</i>
<i>et al.</i>	<i>et ally</i>
Fig.	Figure
g	Gram (s)
g/cm ³	Gram per cubic centimeter
h	Hour (s)
hp	Horse power
ICAR	Indian Council of Agricultural Research
i.e.	that is
%	Per cent
kg	Kilogram
kg/cm ²	Kilogram per square centimeter
kgf	Kilogram-force
kg/h	Kilogram per hour
kg/m ³	Kilogram per cubic meter
kWh	Kilo watt hour

l	Liter
m	Meter
m ³	Cubic meter
min	Minute (s)
mg	Milligram (s)
ml	Milliliter (s)
mm	Millimeter
N	Newton
NHB	National Horticulture Board
RH	Relative humidity
rpm	Revolution per minute
s	second (s)
T	Tonnes
TA	Texture analyser
V	Volt
W	Watt

**COLLEGE OF FOOD PROCESSING TECHNOLOGY & BIO-ENERGY
ANAND AGRICULTURAL UNIVERSITY
ANAND – 388110**

**Dr. R. F. Sutar
Professor and Head (FPT&BE)**

**Tel. No. (02692) 261302
Email: rfsutar@aau.in**

CERTIFICATE

This is to certify that the thesis entitled “**MODIFICATION AND EVALUATION OF RAW BANANA PEELING MACHINE**” submitted by Mr. Moradiya Rahul M. in partial fulfillment of the requirement for the award of the degree of **Master of Technology in Food Processing Technology** to the Anand Agricultural University is a record of bonafide research work carried out by him under my guidance and supervision.

Place: Anand

(R. F. Sutar)

Date: / /2014

Major Advisor

CHAPTER I

INTRODUCTION

Banana (*Musa paradisiaca*) is called as “Apple of Paradise” because it is the one of oldest cultivated fruit known to mankind (Sonawane *et al.*, 2011). Banana is a commercially important tropical fruit crop in the world trade. Banana is considered to be one of the most important sources of energy in the diet of people living in tropical humid regions (Aurore *et al.*, 2009). Banana is one of the widely grown and consumed fruits due to their distinct aroma and taste, in all parts of the world.

The banana fruit is not seasonal in nature like many fruits and is available in fairly large quantity throughout the year. It is the staple food and economic life line for many countries. Banana is cultivated over 130 countries, along the tropics and sub tropic of Capricorn. It is now cultivated throughout the tropics. It is cheap source of carbohydrate and rich source of potassium, calcium, antioxidants and other micronutrients (Aparicio *et al.*, 2007). *Musa sapientum* which is commonly called banana is herbaceous plant of the family Musaceae (Pawar, 2011).

India ranks first in production of banana (17%) of world production. India is the largest producer of banana and plantains in the world with a production of 16.82 million tonnes from an area of 0.49 million ha (Sonawane *et al.*, 2011). The major banana producing states are Maharashtra, Kerala, Tamilnadu, Gujarat, Bihar, West Bengal, Assam, Andhra Pradesh and Karnataka (Mohapatra *et al.*, 2010). Bulk of the production caters mostly to the domestic need, with an estimated domestic consumption of 13445130 MT (FAO, 2009). The large quantity of unmarketable fruits available in all banana growing regions in India wasted due to improper post harvest handling and lack of processing technology for value addition (Kajuna *et al.*, 1997).

Banana is a fast growing and high biomass-yielding plant. There are approximately 1200 seedless fleshy fruit varieties. They are cultivated primarily for their fruit, and to a lesser extent to make fibre and as ornamental plants. The fruit stalk or bunch is the organ of interest for banana cultivation, primarily for food purposes. A period of about 8-13 months exists between planting the banana tree and harvesting bunches, which can contain 100-400 fruit (Pawar, 2011).

The *Musa sapientum* grows up to a height of about 2-8 m with leaves of about 3.5 m in length. The stem which is also called pseudo stem produces a single bunch of banana before dying and replaced by new pseudo stem. The fruit grows in hanging cluster, with twenty fruits to a tier and 3–20 tiers to a bunch. The fruit is protected by its peel which is discarded as waste after the inner fleshy portion is eaten (Molla *et al.*, 2009). An industrial single-cropping, without rotation, which employs many inputs, producing for export, Banana plants ratio is 900-2000 individuals per hectare. Fruit yields may reach 50-70 tonnes/ha (Aurore *et al.*, 2009).

Banana fruits are in the shape of a long curving cylinder. The bottom end narrows to a point and the top end has a thick stem that attaches the fruit to the inflorescence stalk. A small group of banana is termed "hands". Hands are collectively known as "bunches". Banana skin is smooth and thick, and often has a few vertical ridges that run the length of the fruit. The flesh is creamy white and soft. Banana fruits are usually yellow (green when unripe), but there are also red and brown cultivars (Nelson *et al.*, 2006).

Banana fruits are harvested in the unripe stage when the fruits are still green and firm. The harvested banana pass through three physiological developmental stages, namely the pre-climacteric or 'green life' stage, the climacteric or ripening stage which covers the eat-ripe, and finally the senescence stage when the fruits are over-ripe and dying (Pawar, 2011).

Banana is consumed directly as raw, ripe fruit or processed into pulp-liquid fruit, canned slice, deep-fried wafers, toffees, fruit bars, brandy, etc. Deep-fried wafers of raw as well as ripe banana are a popular snack food in southern India (Kachru *et al.*, 1994).

The waste due to surplus banana production can be minimized by preparing banana wafers and other snack products from the excess banana fruits (Mohapatra *et al.*, 2010). There is tremendous scope of banana processing unit to flourish further with increased acceptance of snack foods. The technology of banana chips making has been developed by CFTRI, Mysore and suggested that two varieties 'Nendran' and 'Dwarf Cavendish' are good for making chip. Four major unit operations are involved in the banana chip making process viz. peeling of banana, cutting into slices, frying and packaging of chips. Out of these unit operations both peeling and slicing are done manually (Anon, 1993).

At present, the chips are made by hand peeling raw banana and slicing the pulp portion in a wooden platform type slicer with mild steel blades and then deep frying in oil. The method is cumbersome, unhygienic and does not produce chips of uniform thickness. Besides it may inflict injury to the operator while slicing (Kachru *et al.*, 1994).

Banana is considered as critical fruit for peeling due to uneven, irregular shape and certain kind of cellular fibre around flesh as peel. However, peeling by hand is a relatively slow operation and involves substantial labour when a large number of peeled banana are desired. Manual peeling is not only tedious and time consuming, but is also difficult to manage, because of labour scarcity and maintaining hygiene (Pawar, 2011).

Banana peeling machine was designed and fabricated at the College of Food Processing Technology and Bioenergy, AAU, Anand (Pawar, 2011), to peel the banana by considering basic data of physical and mechanical properties of banana fruit. Mechanised banana peeling machine has many advantages like higher capacity of peeling, it saves energy and hygiene banana processing operation can be achieved, effectively than traditional manual peeling.

The performance evaluation of the machine was carried out. It was found to have a capacity of about 100 kg/h and peeling efficiency from 76.19 % to 93.18 % (Pawar, 2011). The machine was evaluated using mature semi ripe and slightly soft banana fruits since the peeling mechanism is not effective on hard raw banana fruits. The banana fruit being curved in nature could not be used directly and was cut into two pieces to facilitate proper cutting and peeling. Moreover, it is found that the peeling mechanism caused considerable damage to the flesh of the fruit. Hence, this machine needs modification to reduce the damage to peeled fruit. The research work is proposed with the following specific objectives.

- To modify the developed banana peeling machine to improve its performance.
- To design an effective mechanism for feeding, guiding and maintaining depth of peeling for reduction in fruit damage.
- To evaluate the performance of the modified banana peeling machine for different size of banana fruits.

CHAPTER II

REVIEW OF LITERATURE

This chapter deals with brief review of relevant literature pertaining to various parameter involved in present investigation. The review covers the general information regarding banana fruit and various peeling mechanism used to peel the banana fruit.

2.1 Banana

2.1.1 Status of banana

India is the largest producer of banana and plantains in the world with a production of 16.82 million tonnes from an area of 0.49 million ha (Sonawane *et al.*, 2011). The major banana producing states are Maharashtra, Kerala, Tamilnadu, Gujarat, Bihar, West Bengal, Assam, Andhra Pradesh and Karnataka (Mohapatra *et al.*, 2010). Bulk of the production caters mostly to the domestic need, with an estimated domestic consumption of 1.3×10^7 MT (FAO, 2009). Large quantity of fruits are wasted due to improper post harvest handling and lack of processing technology for value addition (Narayana *et al.*, 2002).

2.1.2 Health benefits and nutritional value of banana fruit

Bananas are an excellent source of vitamin B₆, soluble fiber, and contain moderate amounts of vitamin C, manganese and potassium (Molla *et al.*, 2009). Along with other fruits and vegetables, consumption of bananas may be associated with a reduced risk of colorectal cancer and in women, breast cancer and renal cell carcinoma (Deneo *et al.*, 1996).

Bananas are used in special diets where ease of digestibility, low fat, minerals and vitamin content are required. These special diets are used for babies, the elderly and patients with stomach problems, gout and arthritis. Green

bananas possess anti-diarrheal action. It is traditionally used to cure intestinal disorders (Aurore *et al.*, 2009).

Table 2.1 Nutritional value of raw banana

Nutritional value per 100 g (Liggins <i>et al.</i> , 2000)					
Proximate			Vitamins		
Water	g	65.28	Vitamin C, total ascorbic acid	mg	18.4
Energy	kcal	122	Thiamin	mg	0.052
Energy	kJ	510	Riboflavin	mg	0.054
Protein	g	1.3	Niacin	mg	0.686
Total lipid (fat)	g	0.37	Pantothenic acid	mg	0.26
Ash	g	1.17	Vitamin B ₆	mg	0.299
Carbohydrate	g	31.89	Choline, total	mg	13.5
Fiber, total dietary	g	2.3	Vitamin E (alpha-tocopherol)	mg	0.14
Sugars, total	g	15			
Minerals			Lipids		
Calcium, Ca	mg	3	Fatty acids, total saturated	g	0.143
Iron, Fe	mg	0.6	Fatty acids, total monounsaturated	g	0.032
Magnesium, Mg	mg	37	Fatty acids, total polyunsaturated	g	0.069
Phosphorus, P	mg	34			
Potassium, K	mg	499			
Sodium, Na	mg	4			
Zinc, Zn	mg	0.14			
Copper, Cu	mg	0.081			

2.1.3 Physical and mechanical properties

Kachru *et al.*, (1995) studied physical and mechanical properties of two varieties of green banana fruit namely, Dwarf Scavendish and Nendran. Maximum energy of 686.81 J/m² for Dwarf Scavendish and 724.46 J/m² for

Nendran was required to cut a slice of the fruit. The banana kept in a convex position required the most energy to cut, whereas the plain position was observed to be the best position as for the energy requirement and consumer preference of chip shape (Mwonga *et al.*, 2001).

Table 2.2 Physical and mechanical properties of raw banana

Sr. No.	Properties	Banana Varieties	
		Dwarf Cavendish	Nendran
1.	Dia. (without peel, Max), mm	23.34	37.08
2.	Length (Max), mm	137.00	194.50
3.	Width (Max), mm	66.50	50.00
4.	Peel thickness, mm	3.65	2.95
5.	Single fruit weight (Average)	97.84	201.43
6.	Pulp/peel ratio (Average)	1.39	2.32
7.	Specific gravity (Average)	0.933	1.005
8.	Load required to cut (Max), N	22.40	28.20
9.	Cutting Load per unit width, N/mm	0.754	0.821

2.2 Peeling Mechanism

Sleeper (1927) invented relates to apparatus for peeling pears, or other fruit and vegetables which was firm enough to be impaled and rotated against peeling cutters, and the objects of the invention are to provide special apparatus and cutters, which will effectively peel unsymmetrically shaped fruit and vegetables such as pears or potatoes with minimum hand labour, and with minimum waste

of food material with the skins removed. According to research apparatus comprises first a revolving cutter for centring and reaming out the bloom end of the pear as well as removing an area of skin adjacent the bloom end, and second a revolving impaling spindle upon which the reamed pears are advanced and presented to a special high speed revolving peeling cutter or cutters which rise and fall over the entire surface of the fruits while removing the skin only therefrom along a spiral swaths. Automatic features are incorporated with the above to stop and start actuation of the pear spindle and to discharge the peeled fruit, also a multiple spindle machine is provided to increase the output presided over by a given operative.

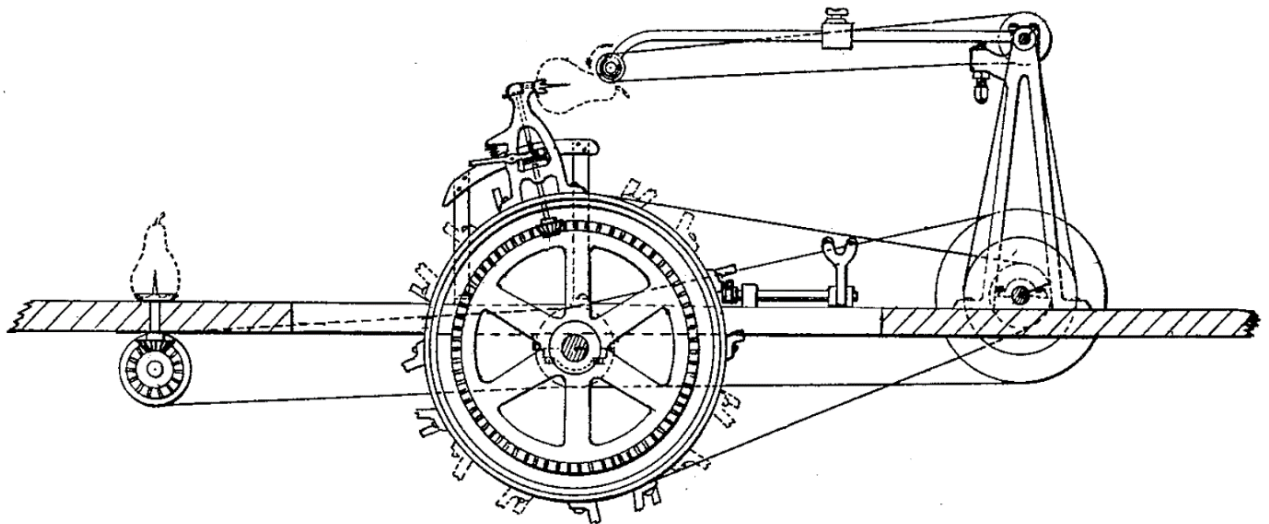

Fig 2.1 Side elevation of pear peeler machine

Casey (1927) made invention related to fruit peeling machine. The machine is only applicable to the peeling of fruit of more or less regular contour from which it was desired to remove a peel of minimum thickness. Because of curved knife being more difficult and dangerous for a person to handle than ordinary flat knife, so a curved knife is much preferable to the ordinary flat knife usually used, since it conforms more nearly to the rounded shape of the fruit and cuts a more uniform thickness of peel, and wastes much less of the fruit. The depth of cut of each knife being controlled automatically the finished fruit has a very neat and finished appearance, and by cutting successively in the manner

disclosed there is much less strain and tension on the ripe pulp of the individual fruits with the result that the fruit is much less mutilated during the cutting operation than is possible under other conditions.

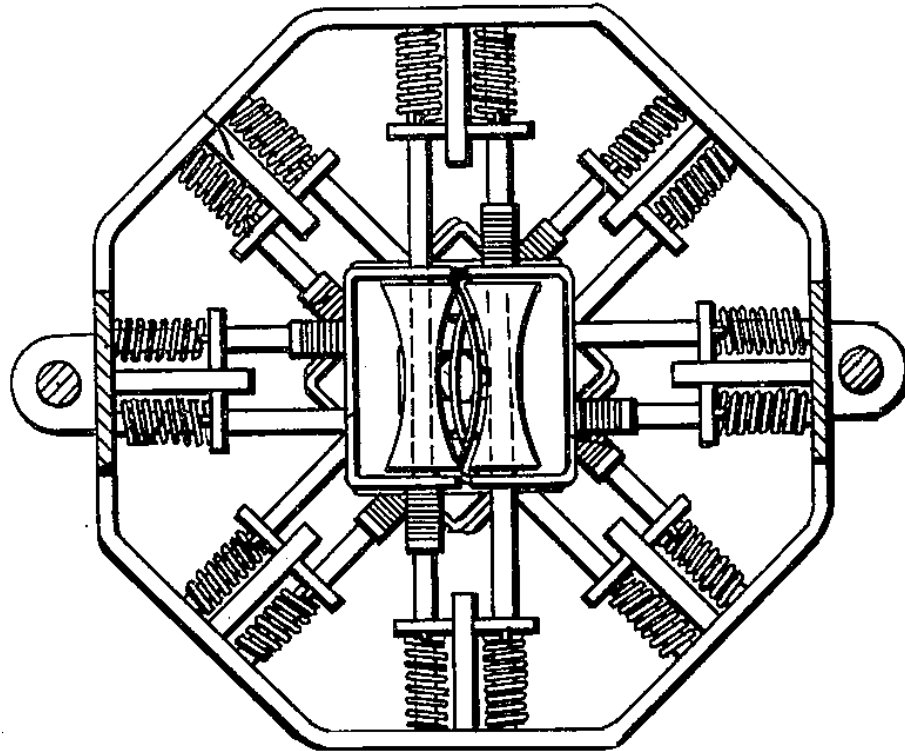

Fig 2.2 Top view of fruit peeling machine

Boyce (1962) invented machinery for processing fruit, and more particularly relates to rotary cutters for peeling fruit, such as pears or the like. The commercial peeling of fruit by means of rotary cutter has not been entirely satisfactory due, in a large measure, to the fact that it is difficult to control the depth of cut of rapidly rotating cutters as they move over the more or less irregular surface of the fruit. Some cutters dig deeply into the fruit at points where the contour of the surface of the fruit changes rapidly, while other cutters skip across such surface leaving unpeeled areas. According to research machinery has provided a rotary cutter assembly particularly adapted to efficient peel the skin from the surface of fruit. The rotary cutter having gauge means adapted to efficient control the depth of the peeling cut.

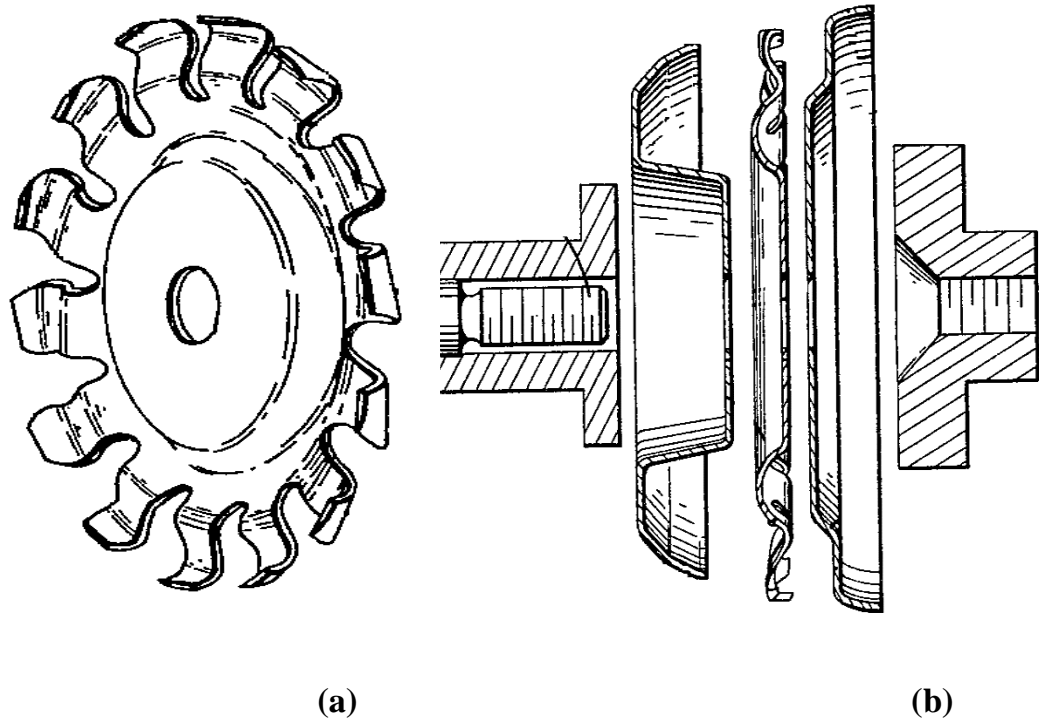

Fig 2.3 (a) Vertical central section of the rotary cutter (b) Cutting blade use in rotary cutter

Harvey and Joseph (1967) made apparatus and method of removing pulp from banana. The apparatus able to take a whole banana and introduce one end of it into a gap between a pair of counter-rotating cylinders. The cylinders pull the peel of the banana there between and in so doing, brush the banana peel and extrude the banana pulp therefrom. The cylinders draw the banana peel through the gap formed there between and deposit it into a suitable receptacle. The banana pulp is directed by the front of the cylinders on to a conveyor where it is moved to a subsequent processing station.

Ralph (1969) developed a method and machine for peeling whole banana so as to obtain whole peeled fruit. In this method for peeling banana included positioning the banana fruit in a predetermined plane and maintaining it there, cutting off the bottom end of the fruit in the predetermined plane, gripping the cut ends of the slit peel segments, and after releasing the holding of the fruit in the predetermined plane, pulling the peel segments in opposite directions from the predetermined plane to strip it from the fruit. The machine has a turret mounting,

having multiple peeling heads rotatable in an orbit and having provision to insert a banana into the head, clamp it in position centred on a reference plane, cut the end from the fruit and split peel from the fruit.

John and Granada (1970) studied apparatus for removing peel from the fruit of banana includes means to guide and position the banana after it is fed into the apparatus and peeling means which cause a plurality of grip members to engage and grip longitudinal segment of the peel and, as the fruit of the banana moves past the peeling means, the grip members pull each segment from the fruit and continue to pull until the peel is completely removed. The peeling mechanism had four resiliently supported rotatable wheels, which self-adjust according to the shape of banana. The wheels grip and pull the peel from fruit of banana, when the banana passes adjacent to the peeling mechanism. The peels which is sliced longitudinally to assist in the removal of peel, is generally engaged and gripped between slices by the peeling units by multiple movable grip members which hold the peel until it is completely removed from the fruit and then release the peel for subsequent disposal.

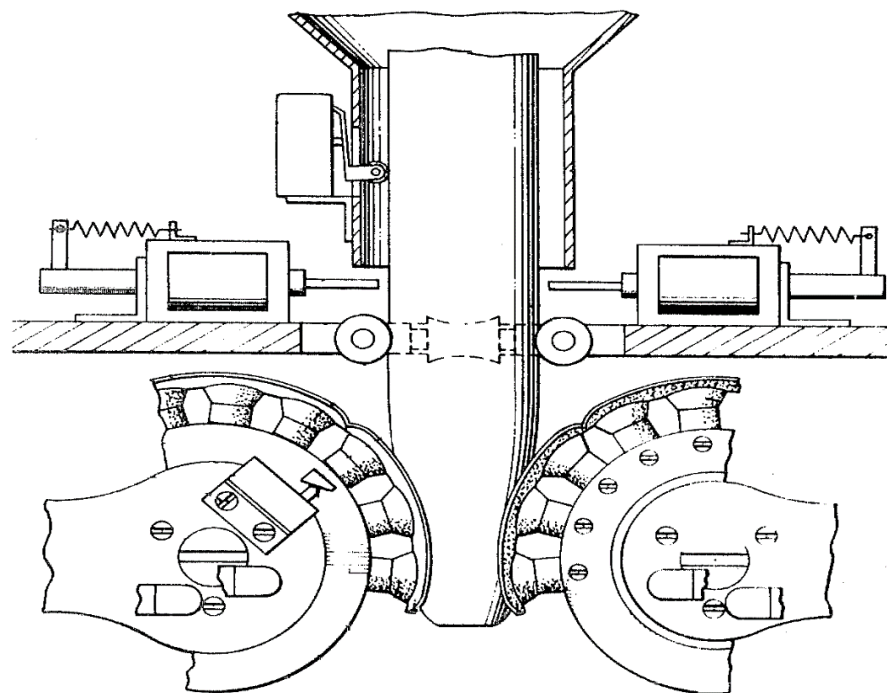

Fig 2.4 Apparatus for feeding and guiding of banana to peeling unit

Leslie (1984) developed banana peeling machine, in which the skin of banana is engaged by impinging spikes on the periphery of three resiliently supported rotatable wheels with separating and cutting means adjacent a narrowest gap location to assist the skin being pulled away from the flesh to effect peeling of banana.

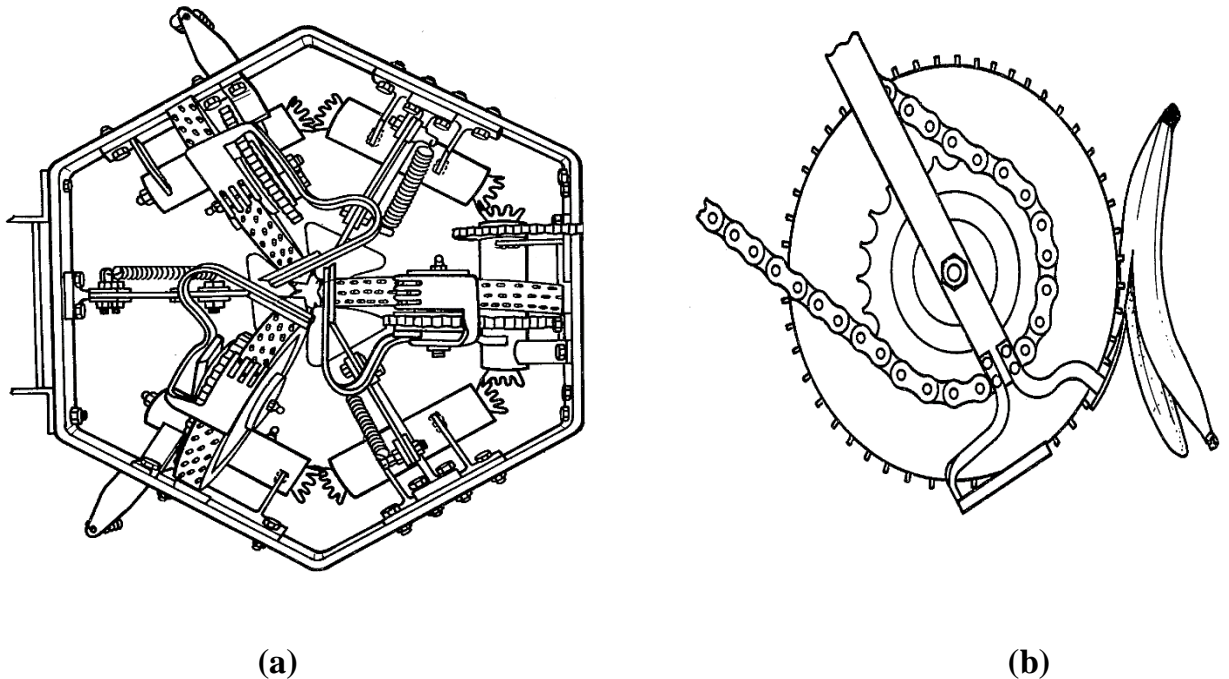

Fig 2.5 (a) Banana peeling machine (b) mechanism for peeling

Berube *et al.*, (1988) developed a machine for cutting strips of peel from citrus fruit, particularly for the purpose of producing twists of lemon and lime, employs a cutting assembly with a circular array of cutter. The cutter have upwardly oriented, transversely extending cutting edge to simultaneously produce a multiplicity of peel strips, they are biased to radially inward position and are automatically retractable so as to accommodate passage of the fruit axially between them. The machine includes a cup for receiving and permitting the convenient retrieval of the fruit and strip from the machine and normally a plunger mechanism will be provided for manually forcing the fruit through the array of cutter.

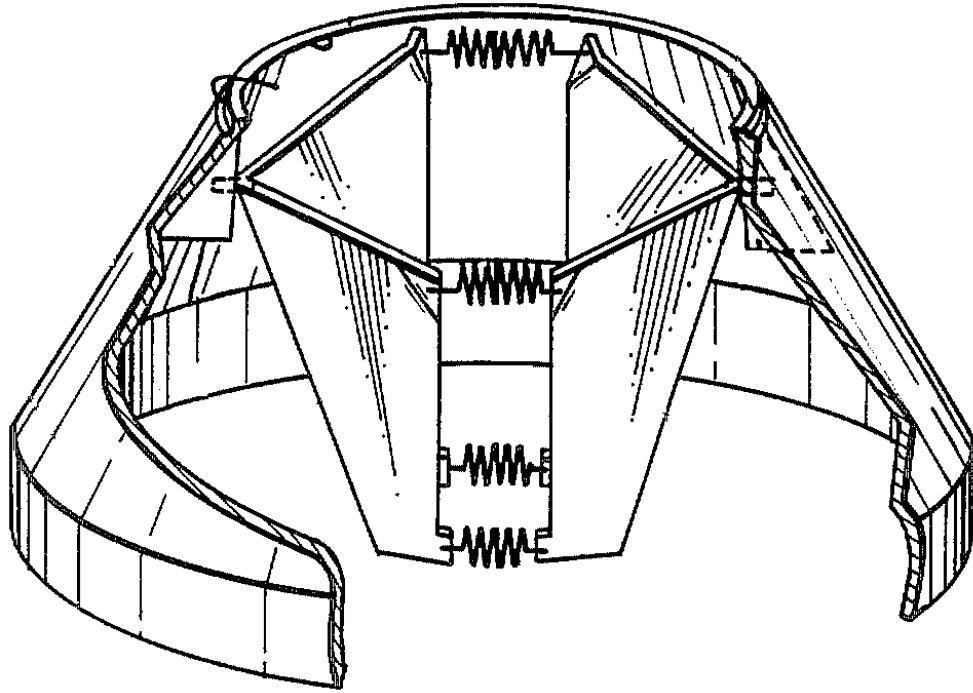

Fig 2.6 Passageway of fruit with spring

Ishikawa (1988) invented a peeling machine for stripping skin and other inedible portions from a fruit or vegetables, more particularly, a peeling machine which can be used effectively for peeling an object which has a soft layer between an outer skin and flesh. This invention is based on a finding that a blade is generally imparted with a better incisive quality when it is pressed against an object and moved in the direction of its cutting edge, as compared with a case where it is simply pressed against the object. Namely, according to the invention, a cup shaped rotary blade with a cutting edge along the brim of a cup-shaped body is put in rotation and moved along the profile of a fruit or vegetable.

The main object of this research is to provide a peeling machine which is adjustable to a position suitable for the size of fruits or vegetable to be peeled, promptly in a facilitated manner according to the average dimensions of the fruits or vegetables.

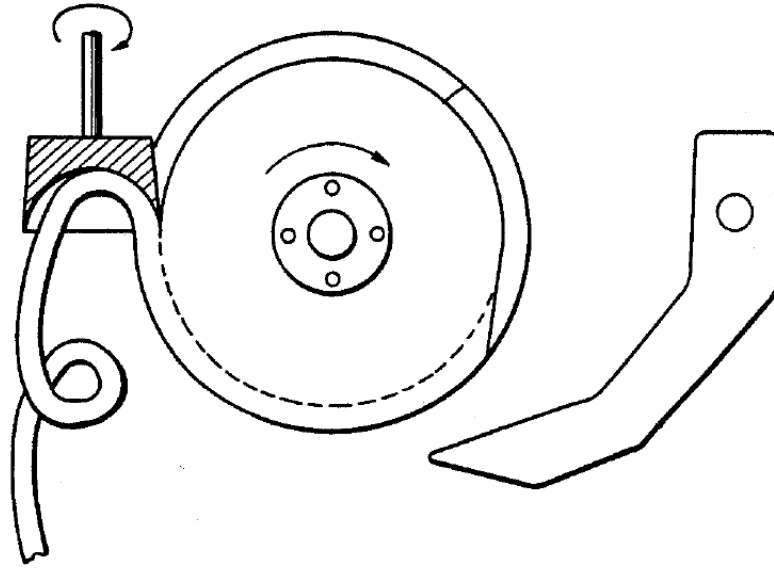

Fig 2.7 Rotary blade with a cutting edge

Gonzalvo (1992) perfected machine for peeling orange and similar fruits. This machine consists of a chassis equipped with two arms, at the ends of which are devices for holding the fruit and turning it. The cutter can be fixed, with the fruit being kept in contact out by angling the axis of the fruit, or it can move round the fruit, and in this case of fruit is fixed. The movement of the cutter in relation to the fruit or vice versa is proportional, so the fruits remain centred in relation to the arms which support it.

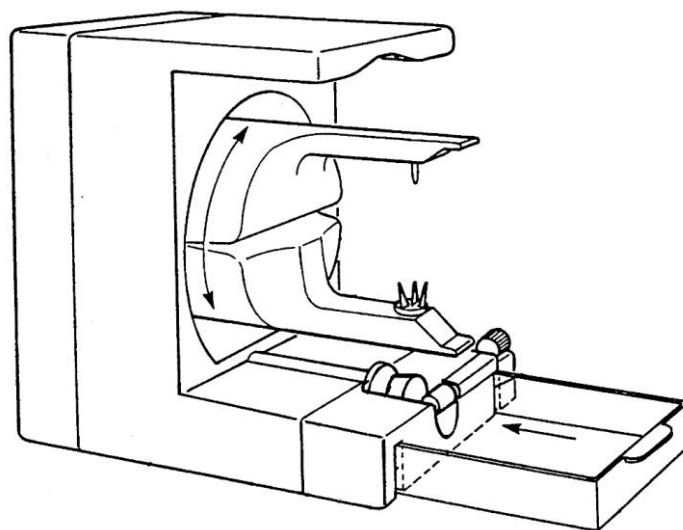

Fig 2.8 Angled view of fruit peeling machine

Rodriguez (1995) developed a device for peeling a green banana, comprising a handle to be grasped by hand of a person. A curved peeling tip extends outwardly from an end of the handle to fit under a skin of the green banana and plantain, in which both ends are cut off and the skin has a plurality of lengthwise slits. A curved shield extends at a rearward angle up from a top surface of the curved peeling, so as to protect a nail of a thumb of the first hand grasping the handle when pushing forward to peel the skin off of the green banana and plantain held in a second hand of the person.

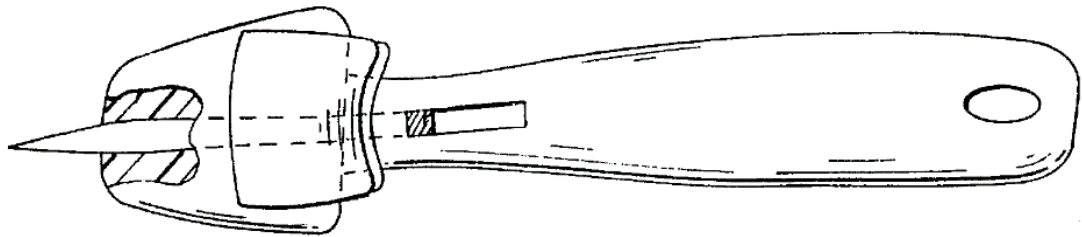

Fig 2.9 Top view of a modified tool containing a retractable knife blade

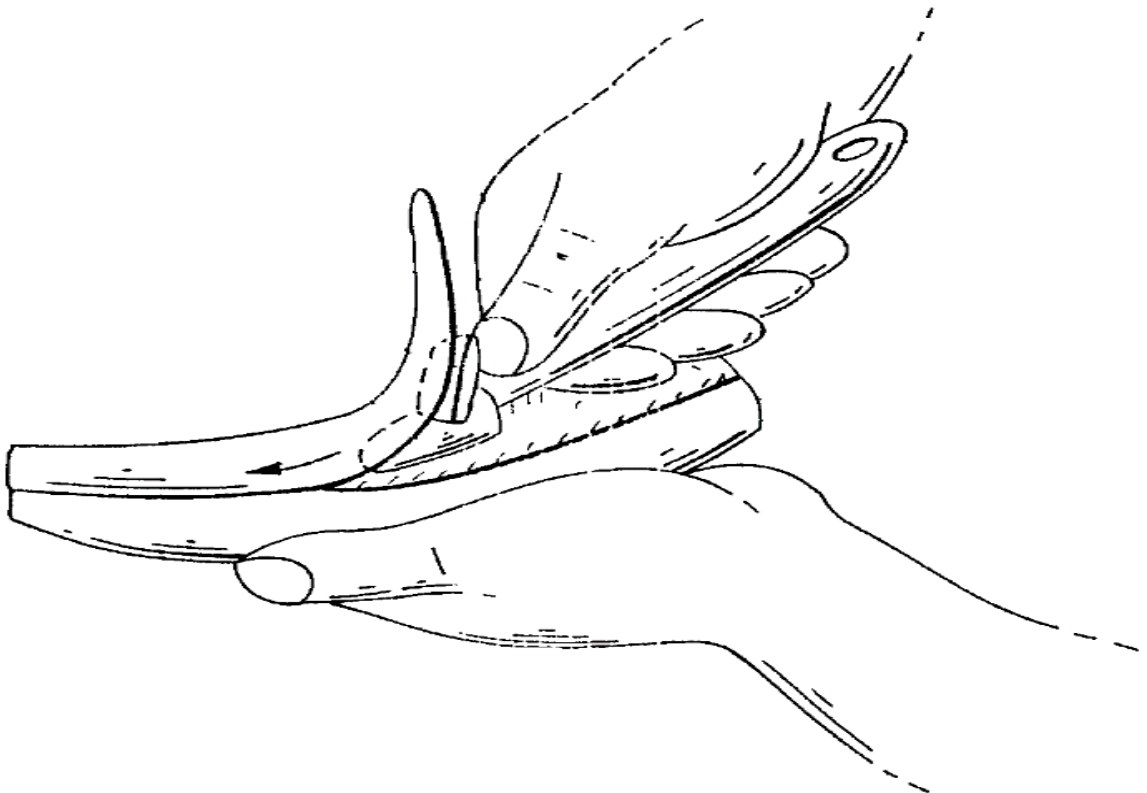

Fig 2.10 Perspective view that shows peeling of green banana by hand

Anaiboni (2003) designed plantain peeler that allows a person to easily and efficiently remove the skin from the plantains. The device would consist of a slicing mechanism and peeling mechanism integrated into housing with a discard tray at the bottom and a plastic backslash surrounding the peeling mechanism. The peeling mechanism would consist of four accurate blades arranged in a circular manner that would force the peel from the plantain as it passes through the mechanism. The discard tray is provided at the bottom of the device to catch the peel, tip retrieval opening would be provided in the housing behind the slicing mechanism, and plantain retrieval passage would be provided in the housing behind the peeling mechanism as shown in the Fig 2.11.

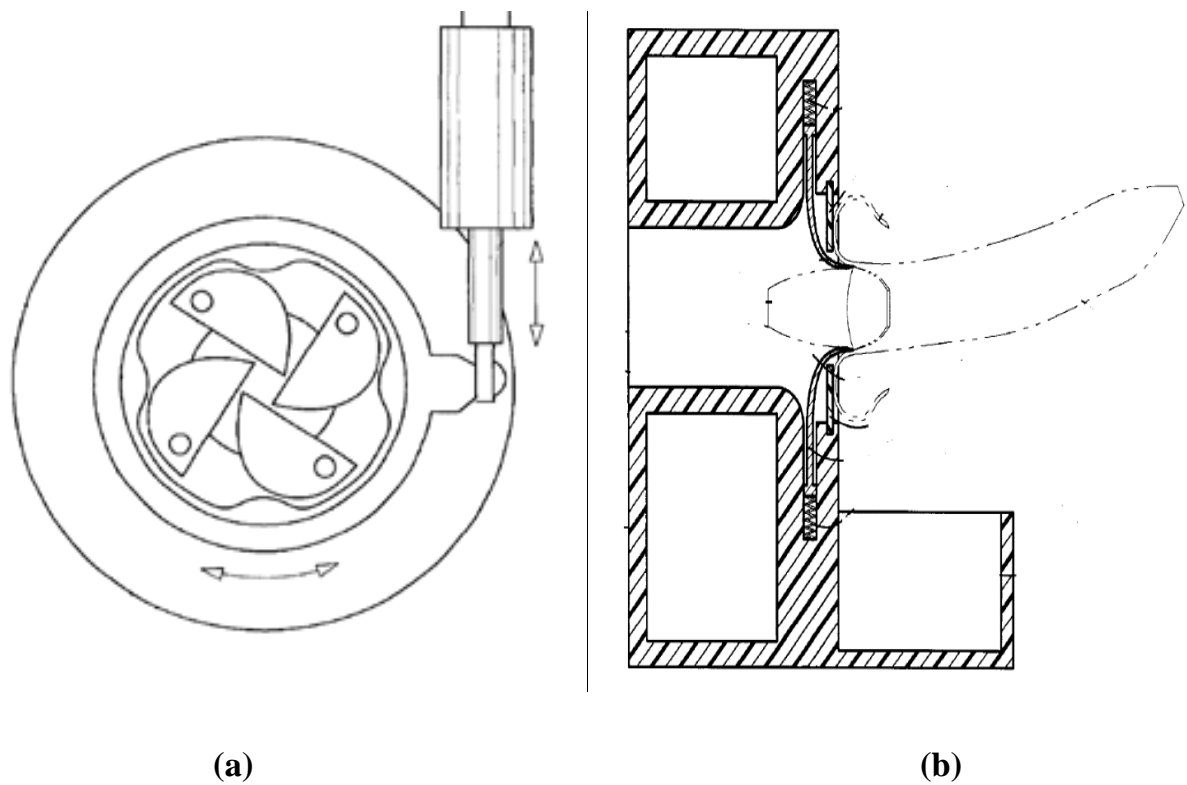

Fig 2.11 (a) Side view of plantain peeler (b) Adjustable cutting blade

Lenscott (2004) invented a green banana safety cutter that consists of a safety cutter for peeling green banana or plantain wherein a handle portion is provided adjacent to a head portion which carries a peeling element with dual opposing peeling blades. The dual opposing peeling blades are relatively widely

spaced apart at approximately 5/6” to allow the peeling element to cut through the tough, thick skins of a green banana or plantain. The cutter is also provided with an elongate retractable cutting blade which is used to first cut off either end of the green banana or plantain to allow it to be easily peeled. The plantain or green banana peeler is preferably provided into two halves secured by a bolt which allows either, the peeling element and/or the retractable blade to be changed by the user when they become dull or worn.

Rafael (2007) worked on method for separating banana pulp from its peel and a device for the implementation of this method. In this method banana is separated into two parts (generally in transverse direction), each part having a tip and a cut end. A compression force is applied to those banana parts such that the force increases from the tip end to the cut end. A device which implements process comprising a cutting device, a means for feeding banana into the cutting device and two processing conveyor devices (to apply the compression force to banana parts).

Pawar (2011) designed and developed a continuous banana peeling machine. The machine consists of two endless belt rotating on pulleys, between which the banana fruit is conveyed. The fruit is first slit and then two projected blades removed and separate the peel from the fruit. The average operating capacity at speed ranges 35-50 rpm, 50-60 rpm, 60-70 rpm and 70-80 rpm were 91.39 kg/h, 107.76 kg/h, 109.65 kg/h and 140.82 kg/h respectively. The peeling efficiency of machine was increased from 76.19 % to 93.18 % as speed of conveying pulley increased up to 70 rpm, above 70 rpm the peeling efficiency of machine was decreased. Damage percent was found in between 6.81 % to 23.8 %. Damage percentage was 23.8 % when machine operated at high speed 80 rpm.

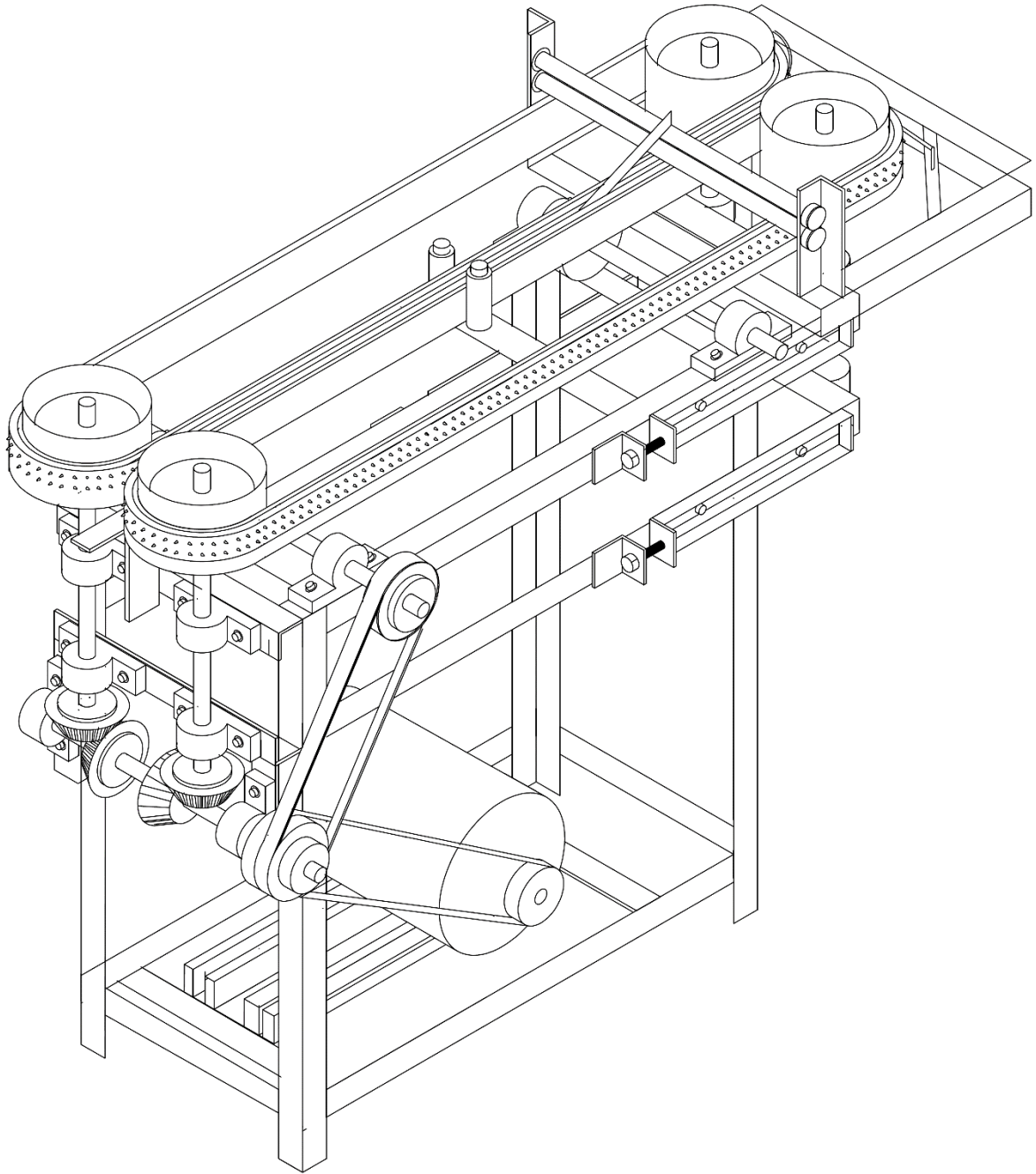

Fig 2.12 Isometric view of banana peeling machine

CHAPTER III

MATERIALS AND METHODS

This chapter deals with design and development aspects of the banana peeling machine. This chapter describes methodology for determination of some engineering properties of banana fruit, design consideration of various components of the machine, constructional details of developed banana peeling machine and the performance evaluation of the developed machine.

3.1 Measurement of Physical Properties of Banana Fruit

Physical and engineering properties of banana like effective length, unit mass, diameter of banana, thickness of peel, etc, are essential for designing of machine. These physical and engineering properties were used to design the different component of banana peeling machine.

These properties were determined by using method suggested by Mohesenin (1980). The different procedures followed for measurement of physical properties are described as below.

3.1.1 Raw materials

Robusta variety of banana was selected and procured from Anand fruit market and *Gana* village, Anand, for determination of their physical and engineering properties. The fruits were washed and then grouped according to their size from the same bunch of that variety. The tests were performed in five replications.

3.1.2 Dimensions of banana fruit

The dimensions of banana fruit, effective length (L), thickness of peel (t), diameter with peel (D) and without peel (d) were measured with the help of vernier caliper (Fig 3.1). Since banana fruit does not have uniform diameter, it was cut into three pieces, i.e. top, middle and tail end.

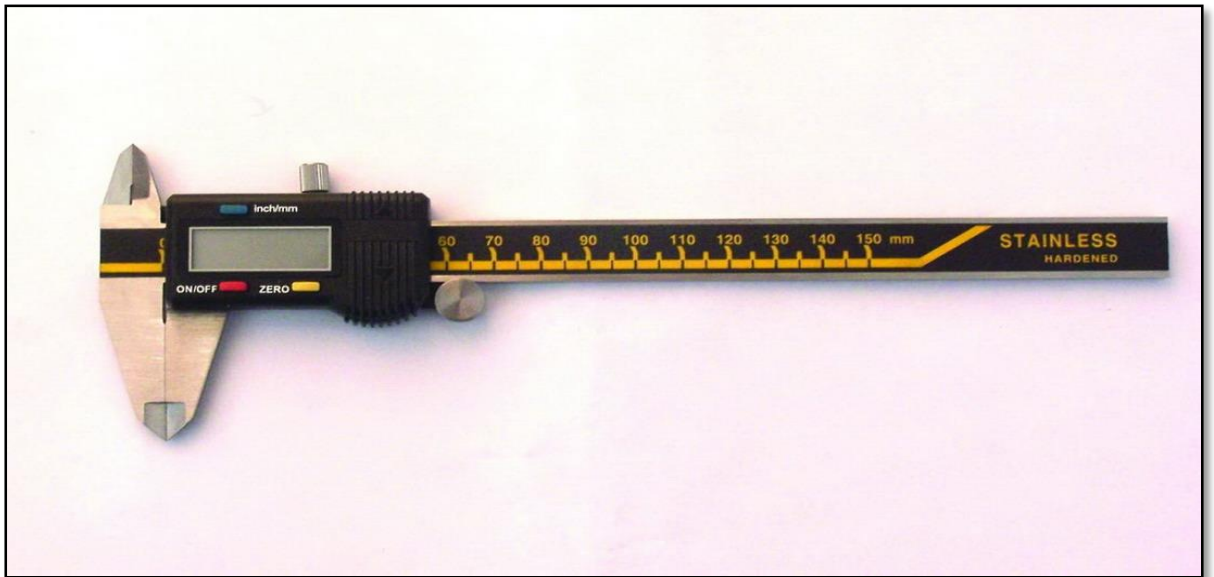

Fig 3.1 Digital caliper

3.1.3 Pulp to peel ratio

The weight of whole bananas, pulp weight and peel weight were determined individually using an electronic precision top pan balance having least count of 0.01 g. The data was used to determine pulp to peel ratio of banana. Pulp to peel ratio of banana were determined by using following equation (3.1).

$$\text{Pulp to peel ratio} = \frac{\text{Weight of pulp}}{\text{weight of peel}} \quad \dots (3.1)$$

3.2 Design Concept of Banana Peeling Machine

The banana peeling machine will consist of a feeding, conveying, peeling and power transmission mechanisms. Based on earlier studies the major modifications will be on improving the peeling mechanism and simplifying the conveying mechanism. In order to reduce damage to the fruit the slitting and peeling mechanism will have adjustable platform.

The following modification were considered

- i. Guiding channel to be provided at the feeding and discharge end
- ii. Slitting mechanism to be provided on both top and bottom sides
- iii. Conveying belts will be horizontal with suitable pusher and guide rollers to avoid slippage
- iv. Peeling will be achieved by a specially designed nib mounted on roller mechanism with provision to adjust the spacing based on thickness of banana fruit
- v. The peeling unit will be adjustable to accommodate different sizes of banana fruit
- vi. The nib will penetrate in two halves of the banana fruit at the centre of the fruit made on the skin. The forward motion of the fruit will help to separate the skin from the hard pulp.
- vii. Mechanical drive is provided from the electric motor, situated at the base of machine. Power transmission is given by v-belt drive from motor to horizontal conveying pulley.



Fig 3.2 Banana peeling machine

3.3 Component of Banana Peeling Machine

Banana peeling machine is divided in to four major units

3.3.1 Frame

Frame is the part on which the whole assembly is placed hence, frame should be strong enough to bear the load of the other components under operating condition without vibration and instability. Frame should be rectangular in shape to provide the strength and firmness to peeling operation, and stability to moving parts during working. The frame of the peeling machine fabricated earlier was used for mounting the other components of the new design concept.

3.3.2 Conveying unit

3.3.2.1 Belt and pulleys

Two canvas flat belts were used for banana peeling machine. The two belts were placed side by side and move on vertical pulleys. Belts and pulleys assembly were design according to physical properties of banana.

3.3.2.2 Belt support plate

At the bottom side of the top part of the frame a small piece of metal plate is provided for supporting belt. Belt support plate reduces the side slipping of the belts, from the bottom.

3.3.2.3 Pusher

This device is fitted over belt surface for connecting two canvas belts. It was placed horizontally on the belt. Main object of the pusher is to push pieces of the banana and convey it toward the peeling unit.

3.3.2.4 Guiding channel

Two vertical plates were fitted over the surface of the belt. These plates work as guiding channel for the banana pieces. These plates also give support and proper direction to the banana piece. As size of the banana varies, the guiding

channel also has mechanism which helps to adjust it manually. There are nuts and bolts provided with plates with which space between two plates can be adjusted.

3.3.2.5 Slitting unit

Slitting unit was placed in the way of conveying path of banana pieces. Two slitting blades were provided which were placed at the upper and lower sides. Slitting blades are sharp enough which cuts the skin of banana effectively. The clearance between two blades can be adjusted manually which controls the penetration of blades in the banana with minimum damage.

3.3.2.6 Pulp collection channel

After the peeling unit there is a provision to collect the peeled banana fruit.

3.3.3 Peeling unit

3.3.3.1 Telescopic Channel

The telescopic channels consist of two M.S channels, one inside the other, sliding over metal balls that roll easily. According to size of banana pieces whole assembly adjust itself and reduces the damage. Rollers were mounted on the telescopic channel with the pins.

3.3.3.2 Rollers and pins

Rollers are most important part in peeling unit. Two equal size rollers of mild steel are placed on the adjustable telescopic channel. Ball bearings were fitted in the inner side of the rollers for smooth movement over the surface of banana pieces.

3.3.3.3 Spring

A spring is an elastic object used to store mechanical energy. Springs are usually made out of spring steel. When a spring is compressed or stretched, the

force it exerts is proportional to its change in length. As long as they are not stretched or compressed beyond their elastic limit, most springs obey Hooke's law, which states that the force with which the spring pushes back is linearly proportional to the distance from its equilibrium length:

$$F = -kx, \quad \dots (3.2)$$

Where

x is the displacement vector – the distance and direction the spring is deformed from its equilibrium length.

F is the resulting force vector – the magnitude and direction of the restoring force the spring exerts.

k is the rate, spring constant or force constant of the spring, a constant that depends on the spring's material and construction.

The negative sign indicates that the force the spring exerts is in the opposite direction from its displacement.

When the pieces of banana passes through the rollers, both rollers adjusts the clearance between them automatically. Spring plays important role in this operation. The spring was made up with mild steel spring grade material.

3.3.3.4 Separating unit

Separating unit consist of two specially designed nib connected to two bars. It should have enough strength to sustain the load of banana while separating the peel. The nib should penetrate between peel and flesh of fruit. The depth was designed to be adjustable.

3.3.4 Power transmission unit

3.3.4.1 Electric motor

In banana peeling machine suitable 3-ph 3-HP AC electric motor was used. The motor will be used for driving the pulley and conveyor belt arrangement with pusher. Banana peeling machine was driven by three phase AC motor as shown in the Appendix-E.

3.3.4.2 Vertical conveying pulley

Power transmission was done by vertical conveying flat belt pulley. The vertical conveying pulley was connected to motor with the help of v-belt, for reducing slippage.

3.4 Laboratory Equipment for Testing of Banana Peeling Machine

The laboratory test set up consists of the following accessories, equipment's and instruments for conducting laboratory tests of banana peeling machine.

1. Variable frequency drive
2. Power measuring instruments (ammeter, wattmeter)
3. Speed measuring instrument (tachometer)
4. Time measuring instrument (digital stop watch)
5. Weight measurement instrument (weighing balance)

3.4.1 Variable frequency drive (VFD)

A variable-frequency drive (VFD) (also termed adjustable-frequency drive, variable-speed drive, AC drive, micro drive or inverter drive) is a type of adjustable speed drive used in electro-mechanical drive systems to control AC motor speed and torque by varying motor input frequency and voltage.

A variable frequency drive is a device used in a drive system consisting of the following three main sub-systems: AC motor, main drive controller assembly, and drive operator interface.

The AC electric motor used in a VFD system is usually a three-phase induction motor. Motors that are designed for fixed-speed operation are often used. Elevated voltage stresses imposed on induction motors that are supplied by VFDs. The VFD controller is a solid state power electronics conversion system consisting of three distinct sub-systems: a rectifier bridge converter, a direct current (DC) link, and an inverter. Voltage-source inverter (VSI) drives are by far the most common type of drives. In a VSI drive, the DC link consists of a capacitor which smooth's out the converter's DC output and provides input to the inverter. This filtered DC voltage is converted to AC voltage output using the inverter's active switching elements.

The operator interface provides a means for an operator to start and stop the motor and adjust the operating speed. Additional operator control functions might include reversing, and switching between manual speed adjustment and automatic control from an external process control signal. Specifications of VFD as shown in the Appendix-F.

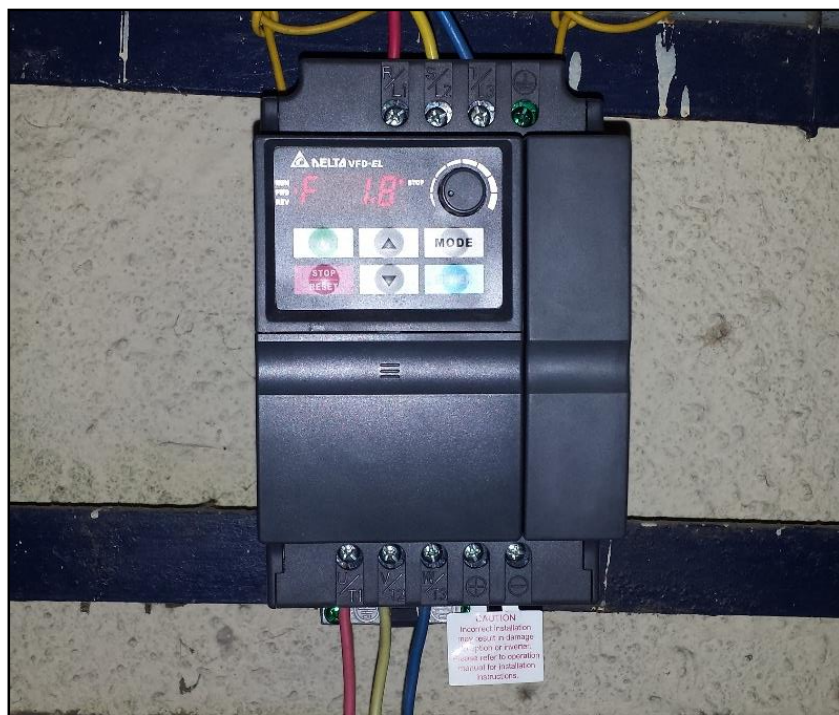

Fig 3.3 Variable frequency drive (VFD)

3.4.2 Power measuring instruments

The input power to the banana peeling machine was calculated by measuring the input power to the motor. Input power to motor is determined with the help of ammeter, voltmeter and wattmeter. Ammeter was used to measure the input electric current per phase while voltmeter was used for measuring the line voltage. The ammeter and voltmeter were connected to the power supplying line in parallel connection.

Specification of Ammeter

Range : 0-5 Amp

Least count : 0.01 Amp

Phase : single \emptyset

Specification of Wattmeter

Range : 0-75 W

Single phase element electrostatics



Fig 3.4 Wattmeter

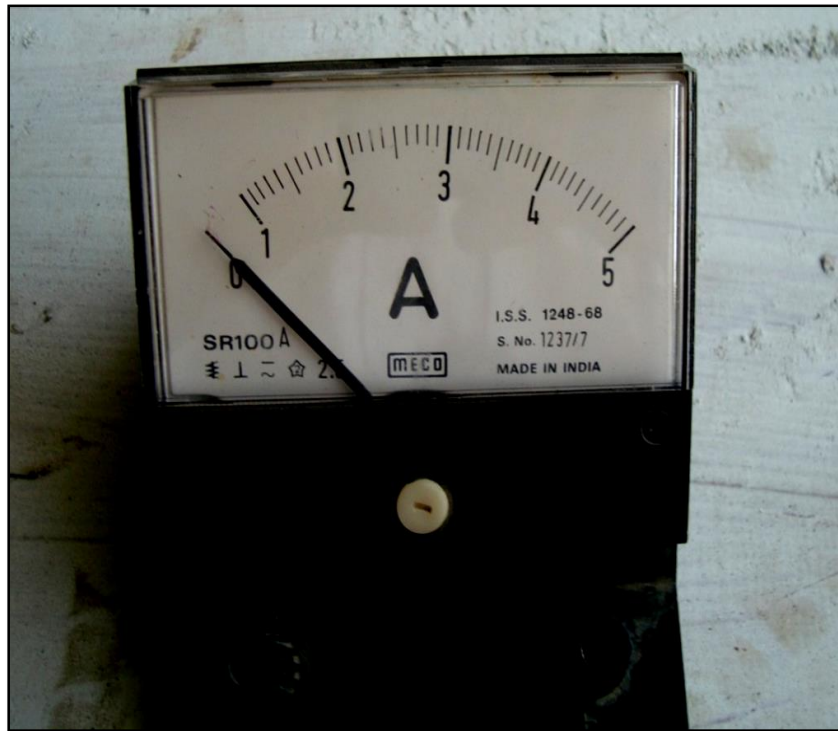

Fig 3.5 Ammeter

3.4.3 Speed measuring instrument

Non contact, digital photo type Tachometer (Fig 3.6) was used to measure the rpm of horizontal conveying pulleys.



Fig 3.6 Digital tachometer

3.4.4 Time measuring instrument

Digital stop watch was used to measure the time required in peeling of bananas at different speed range of machine, for evaluating the actual capacity of the machine.

3.4.5 Weight measuring instrument

An electronic weighing balance of 0-10 kg range capacity having least count 0.001 kg was used for weighing of bananas, for evaluating the capacity and performance of the machine.

3.5 Performance Evaluation of Banana Peeling Machine

Performance evaluation of banana peeling machine was done by using raw matured banana in terms of peeling efficiency, output capacity and damage percentage as function of operating speed. The peeling efficiency was measured on the basis of average number of banana fruit effectively peeled.

The peeling efficiency was measured at four different speeds range i.e. 27-75 rpm of the conveying pulley of the machine. These speeds were selected on the basis of preliminary investigation conducted in the previous project.

3.5.1 Capacity of machine

The operating capacity of the machine was determined at different speed ranges, by feeding the half cut bananas into the machine and weighing these banana pieces and time taken by the machine, irrespective of the damage. Before feeding, the total weight and number of fed banana pieces were observed. Effective capacity of machine was measured by considering number of damaged pieces after peeling. The capacity of banana peeling machine is expressed as kg of banana fed per unit time i.e. kg per hour.

3.5.2 Damage percentage

Damage percentage is defined as the ratio of number of damaged peeled banana pieces to the total number of banana pieces before peeling.

$$\text{Damage percentage} = \frac{\text{Number of damaged banana pieces}}{\text{Total number of fed banana pieces}} \times 100 \quad \dots (3.3)$$

The uneven penetration of separating bars may cause damage to the banana fruit. The damaged pieces or broken pieces are defined as those fruits which have deep scraped surfaces or separated into two parts or remain unpeeled.

3.5.3 Peeling efficiency

Peeling efficiency is the inversely proportional to damage percentage. Peeling efficiency can be defined as; ratio of number of peeled banana pieces to the total number of fed banana pieces. The efficiency of peeling was determined by following expression.

$$k = \frac{W_t - W_d}{W_t} \quad \dots (3.4)$$

Where,

K = Peeling efficiency, %

W_t = Total number of fed banana pieces

W_d = Number of damaged banana pieces after peeling.

3.5.4 Effective capacity

Peeling efficiency is useful in the determination of effective capacity of the machine. The effective capacity of machine can be determined by following expression.

$$\text{Effective capacity} = \frac{OC \times k}{100} \quad \dots (3.5)$$

Where,

E. C. = Effective capacity, kg/h

O. C. = Operating capacity, kg/h

k = Peeling efficiency, %.

3.5.5 Feed rate

Feed rate is defined as the ratio of weight of banana pieces to time taken for peel banana pieces.

$$R = \frac{w}{t} \quad \dots (3.6)$$

Where,

R = Feed rate, kg/h

w = Weight of banana pieces, kg

t = time, h

CHAPTER IV

RESULTS AND DISCUSSION

The banana peeling machine was redesigned and fabricated at the workshop of College of Food Processing Technology and Bioenergy, AAU, Anand, considering basic data of physical and mechanical properties of banana fruit. The modified banana peeling machine is evaluated for its performance on basis of its capacity, peeling efficiency, damage percentage and power consumption.

4.1 Physical Properties of Banana

The physical properties of banana fruit were estimated using 150 kg of banana fruit. *Robusta* variety procured from local market, this variety was chosen since it is the most popular for use in preparation of banana chips.

4.1.1 Weight

Weight of the fruit varies depending on variety, maturity of fruit, size etc. The weights of fruits were measured and mentioned in Table 4.1. The weight of banana varies from 83.14 g to 103.1 g, the average being 93.64 g.

Weight of the pulp of banana fruit varies from 60.94 to 74.99 g and average pulp weight banana fruit was 69.03. Weight of the peel of banana fruit varies from 17.68 to 32.96 g. Average peel weight of banana fruit was 24.61.

4.1.2 Effective length

Effective length of banana fruit were measured and presented in Table 4.1. Effective length of banana fruit varies from 121.1 to 142.2 mm. Average effective length of 50 banana fruits was 133.30 mm.

4.1.3 Diameter

Table 4.1 shows the range of average diameter at various planes of cut at top (a), middle (b) and bottom (c) of the banana fruit with and without peel for Robusta variety. It can be observed that the diameter of fruit is less at both the ends and maximum in the middle portion.

The maximum and minimum observed diameters of top cut for banana fruit without peel were 24.87 mm, 22.92 mm respectively and its average was 24.16 mm. The maximum and minimum observed diameters of middle cut for banana fruit without peel were 25.83 mm, 23.73 mm respectively and its average was 25.06 mm. The maximum and minimum observed diameters of bottom cut for banana fruit without peel were 23.31 mm, 21.52 mm respectively and its average was 22.65 mm.

4.1.4 Thickness of peel

Peel thickness varies with variety and maturity of fruit. It also varies along its length. The banana peel is formed by 3-5 longitudinal planes and the joint of these planes forms a ridge. The thickness of peel is more at these ridges than at the other places. Thicknesses of peel for both varieties are tabulated in Table 4.1.

The maximum and minimum observed peel thickness at top cut for banana fruit were 4.01 mm, 3.23 mm respectively and its average was 3.72 mm. The maximum and minimum observed peel thickness at middle cut for banana fruit were 4.26 mm, 3.48 mm respectively and its average was 3.97 mm. The maximum and minimum observed peel thickness at bottom cut for banana fruit were 4.31 mm, 3.53 mm respectively and its average was 4.02 mm. It is observed that thickness of peel were higher at bottom of fruit.

Table 4.1 Physical properties of raw banana fruit

	Effective Length (mm)	Weight banana (g)	Weight of pulp (g)	Weight of peel (g)	Pulp to peel ratio	Diameter of banana with peel (mm)			Diameter of banana without peel (mm)			Thickness of peel (mm)		
						A	B	C	A	B	C	A	B	C
Average	133.30	93.64	69.03	24.61	2.86	31.60	33.01	30.20	24.16	25.06	22.65	3.72	3.97	4.02
Maximum	142.2	103.1	74.99	32.96	3.76	32.88	34.34	31.42	24.87	25.83	23.31	4.01	4.26	4.31
Minimum	121.1	83.14	60.94	17.68	2.03	29.38	30.69	28.08	22.92	23.73	21.52	3.23	3.48	3.53
S. D. (±)	0.56	4.77	3.14	3.55	0.42	0.60	0.63	0.58	0.33	0.36	0.31	0.13	0.14	0.13

4.1.5 Pulp to peel ratio

Pulp to peel ratio were calculated on the basis of weight of pulp and weight of peel as shown in Table 4.1. The maximum pulp to peel ratio of banana fruit was 3.76 and minimum pulp to peel ratio was 2.03 with an average value of 2.86.

4.2 Modified Banana Peeling Machine

The entire mechanism has been modified to obtain effective peeling operation of banana fruit. The modified machine consists of four sub units namely (a) frame (b) conveying unit (c) power transmission unit (d) peeling unit.

Banana peeling machine has been provided with the feeding channel at the entrance through which half cut banana pieces are to be fed. In feeding unit, the machine consists of horizontal conveying belts unit with pusher on it, for the conveying of half banana pieces. Pusher carries the fed banana pieces from the feeding unit to peeling unit as shown in the Fig 4.12.

For maintaining the position and accurate displacement of the banana, guiding channel is provided at the beginning of the conveyor. This guiding channel consists of two vertical roller and guiding plates as shown in the Fig 4.8 and 4.9.

Two vertical guiding rollers are used for keeping the conveyer belt in desired position throughout the peeling operation. The belt support plate also helped in maintaining the position during conveying process.

From earlier trials, it was concluded that for effective peeling it is necessary to slit peel from both side. During conveying of banana pieces, banana peel gets slit from both sides over the top and bottom surface by slitting blades as shown in the Fig 4.12. Due to slitting operation, banana peels get divided into

two portions. In the earlier developed machine the slitting mechanism was provided only for one side.

The separating unit assembly is welded at the middle of conveying unit with the peeling unit and consists of pin and roller assembly mounted on telescopic channel as shown in the Fig 4.7. The rollers helps to adjust telescopic channel according to the size and shape of banana as shown in Fig 4.13. Due to slitting action, banana peel is divided into two parts, this will help to remove peel effectively.

The manually adjustable separating bar assembly is mounted on telescopic channel which helps to remove the peel. To make more efficient separation, separation bars are provided at the discharge end, which is also adjustable. Separation bars penetrates in between peel and pulp and makes it easy to separate pulp and peel as shown in the Fig 4.13.

Power transmission is given by v-belt drive from motor to horizontal conveying pulley as shown in the Fig 4.2. Variable frequency drive (VFD) attached with 3-phase AC electric motor, which is situated at the base of machine as shown in the Fig 4.2 and it helps the machine to be operated at different rpm.

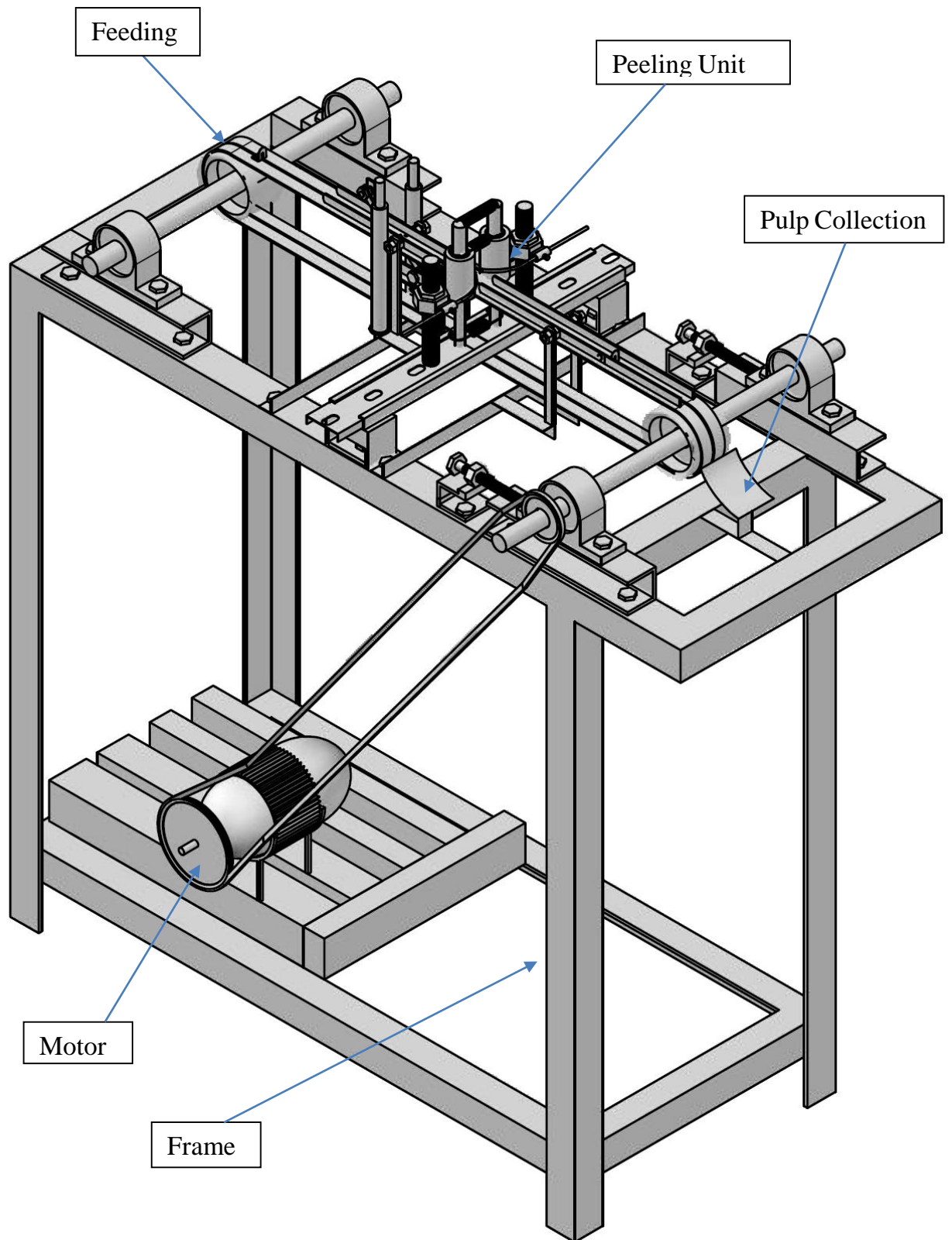

Fig 4.1 Isometric view of banana peeling machine

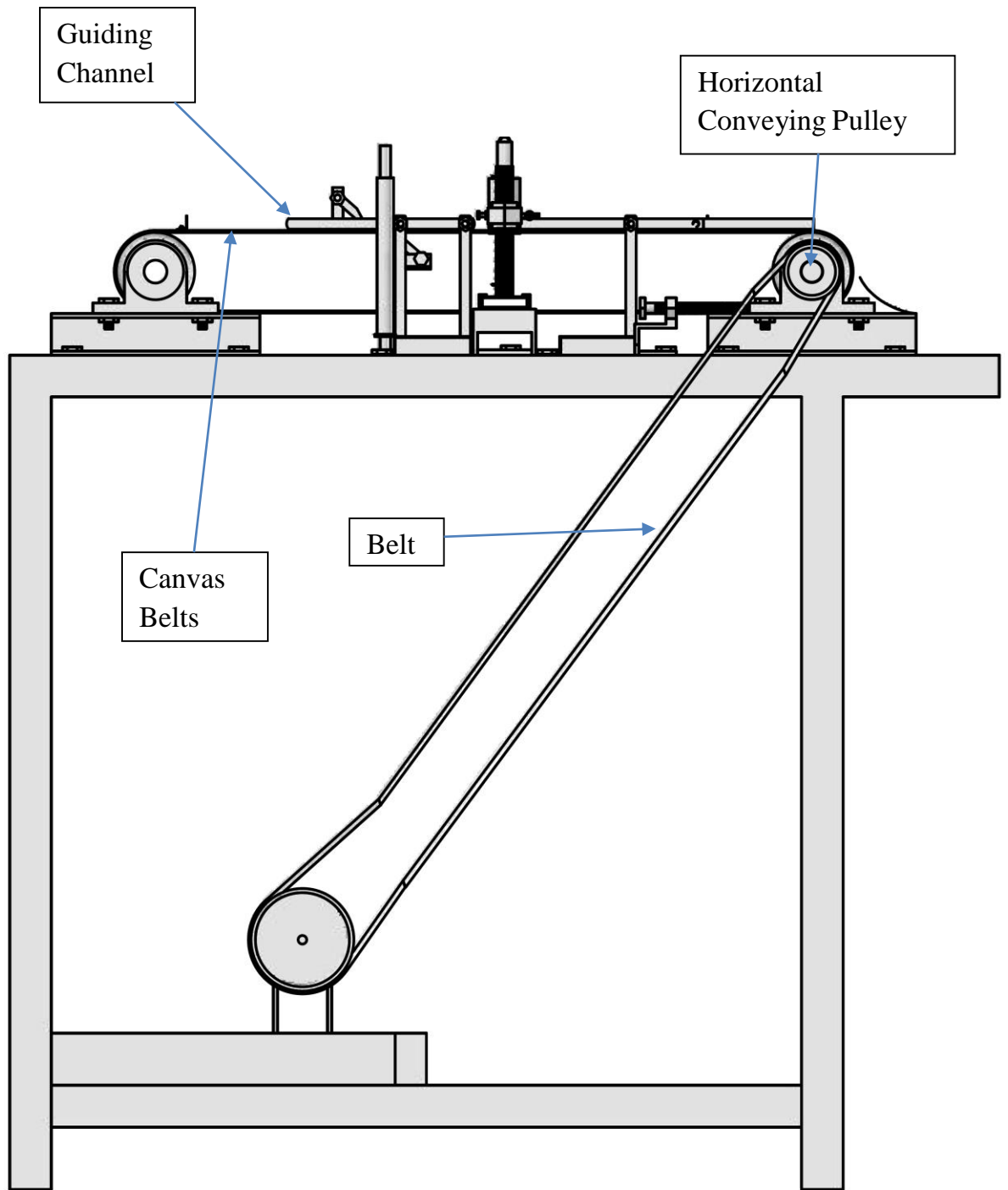

Fig 4.2 Side view of banana peeling machine

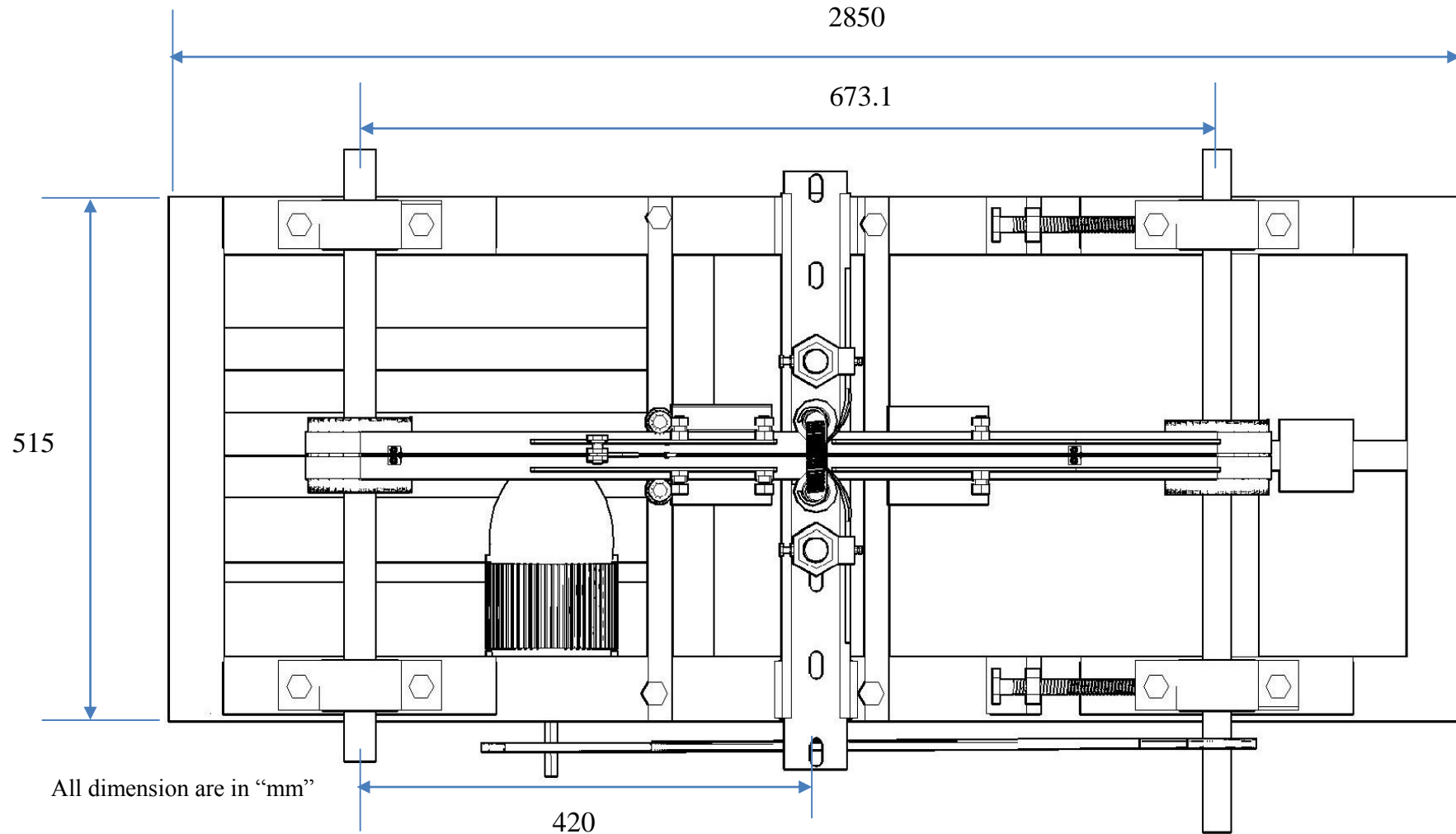

Fig 4.3 Top view of banana peeling machine

4.3 Design and Components of Banana Peeling Machine

4.3.1 Frame and its components

Frame is the main part on which entire peeling assembly and motor is placed. The frame should be strong enough to bear the load of the other components under operating condition without vibration and instability. Existing frame of the earlier designed machine was used without any modification.

To support all components of the conveying unit and peeling unit, the rectangular frame is fabricated from $40 \times 40 \times 5$ mm size mild steel angle sections. Height of upper end of the frame from the ground is taken 800 mm for the convenience during feeding of banana. Hence the length of main frame worked out to be 760 mm. Width of frame is equal to pulleys diameter on both side plus the banana diameter. Thus, the overall dimensions of the frame are $760 \times 370 \times 800$ mm (Fig 4.4).

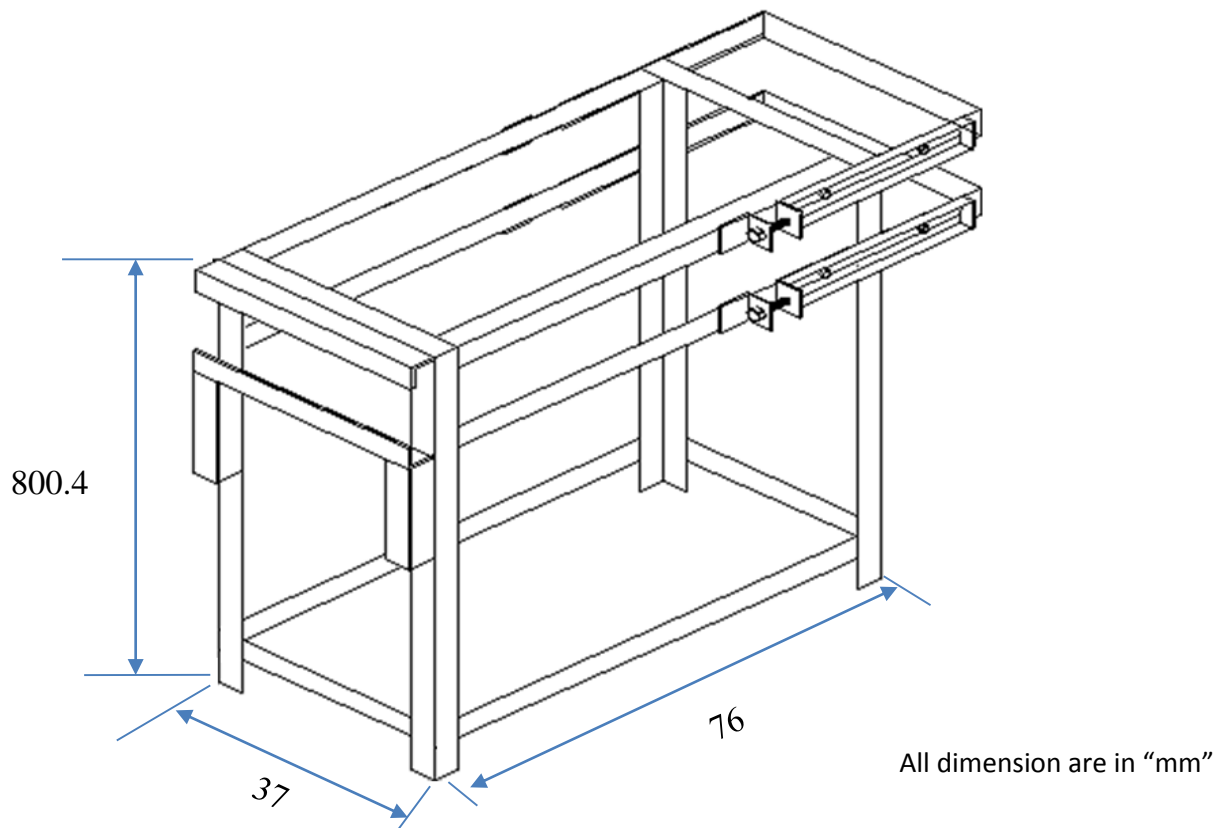

Fig 4.4 Existing frame

4.3.2 Design of conveying unit and its components

4.3.2.1 Belts and pulleys

Conveying unit consists of two canvas belts as shown in the Fig 4.2 and horizontal conveying pulleys as shown in Fig 4.5. The main function of horizontal canvas belts is to convey, guide and pass the bananas through the peeling mechanism.

The width of canvas belt was decided on the basis of maximum diameter of banana and free space for rolling over the pulleys. The maximum diameter of banana with peel was observed to be 34.34 mm as shown in Table 1. The space was given between two belts 4 mm and 12 mm extra width was provided for slippage of belts. So actual width of canvas belt required is diameter of banana plus clearance provided between two belts plus extra for slippage,

$$= 34.34 \text{ mm} + 4 \text{ mm} + 12 \text{ mm}$$

$$= 54.34 \text{ mm.}$$

So width of each canvas belt were selected approximately 25 mm according to above calculation.

The length of canvas belt was decided on the basis of the centre to centre distance between two canvas belt pulleys and diameter of pulley. The length of belt was decided by considering the numbers of bananas carried over the belt during the single path operation.

Considering the existing pulley diameter 152.4 mm, the calculations were made to determine actual length of belt required. Considering 8 half pieces to be carried during operation and distance between two pushers keeping 210 mm for effective feeding operation. The centre to centre distance between canvas belt pulleys was found 673.1 mm.

$$\textbf{Total belt length} = \pi(d) + 2 \times l$$

Where,

d = diameter of pulley (mm).

l = center to center distance between two pulleys

Hence, total length of belt is estimated to be

$$= 3.14 \times 152.4 + 2 \times 673.1$$

$$= 1824.73 \text{ mm.}$$

The nearest belt size available in the market is 1890 mm.

4.3.2.2 Belts support plate

At the bottom side of the canvas belt small piece of angle section of about 60 mm length is provided for supporting the belts. Belt support plate reduces the side slippage of the belts.

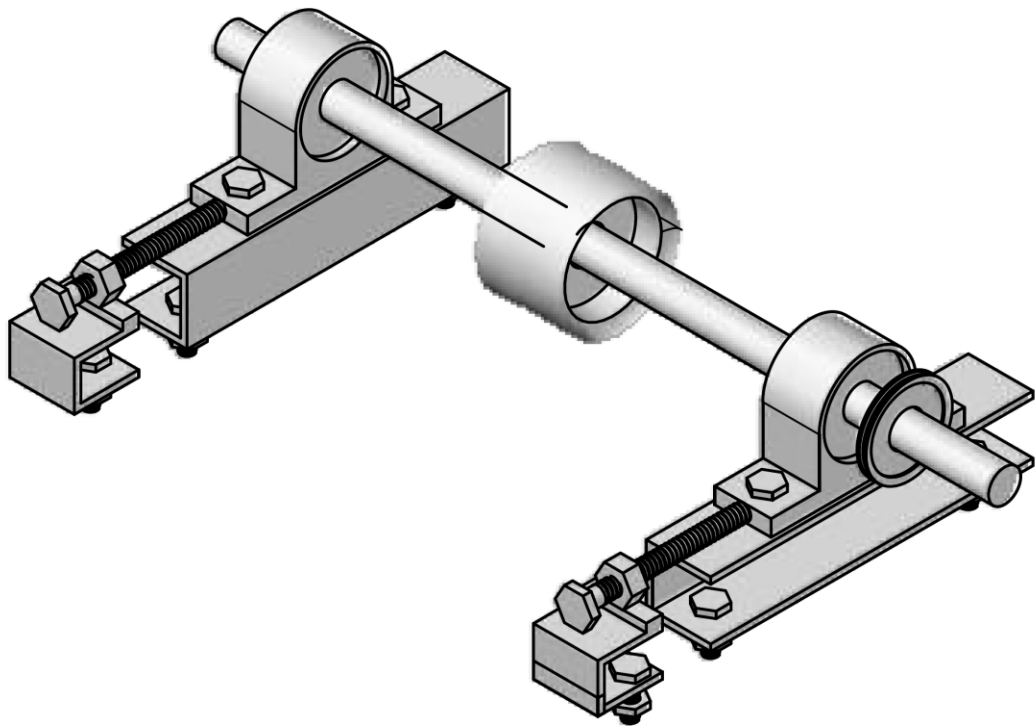

Fig 4.5 Isometric view horizontal pulley and shaft assembly

4.3.2.3 Pusher

Main objective of the pusher is to push the banana pieces and convey it towards the peeling unit. This device is fitted over belt surface for connecting two canvas belts. It is placed horizontally on the belts as shown in the Fig 4.6. The pusher is designed taking in to consideration the cutting knives that, it will encounter along the passage through the peeling mechanism.

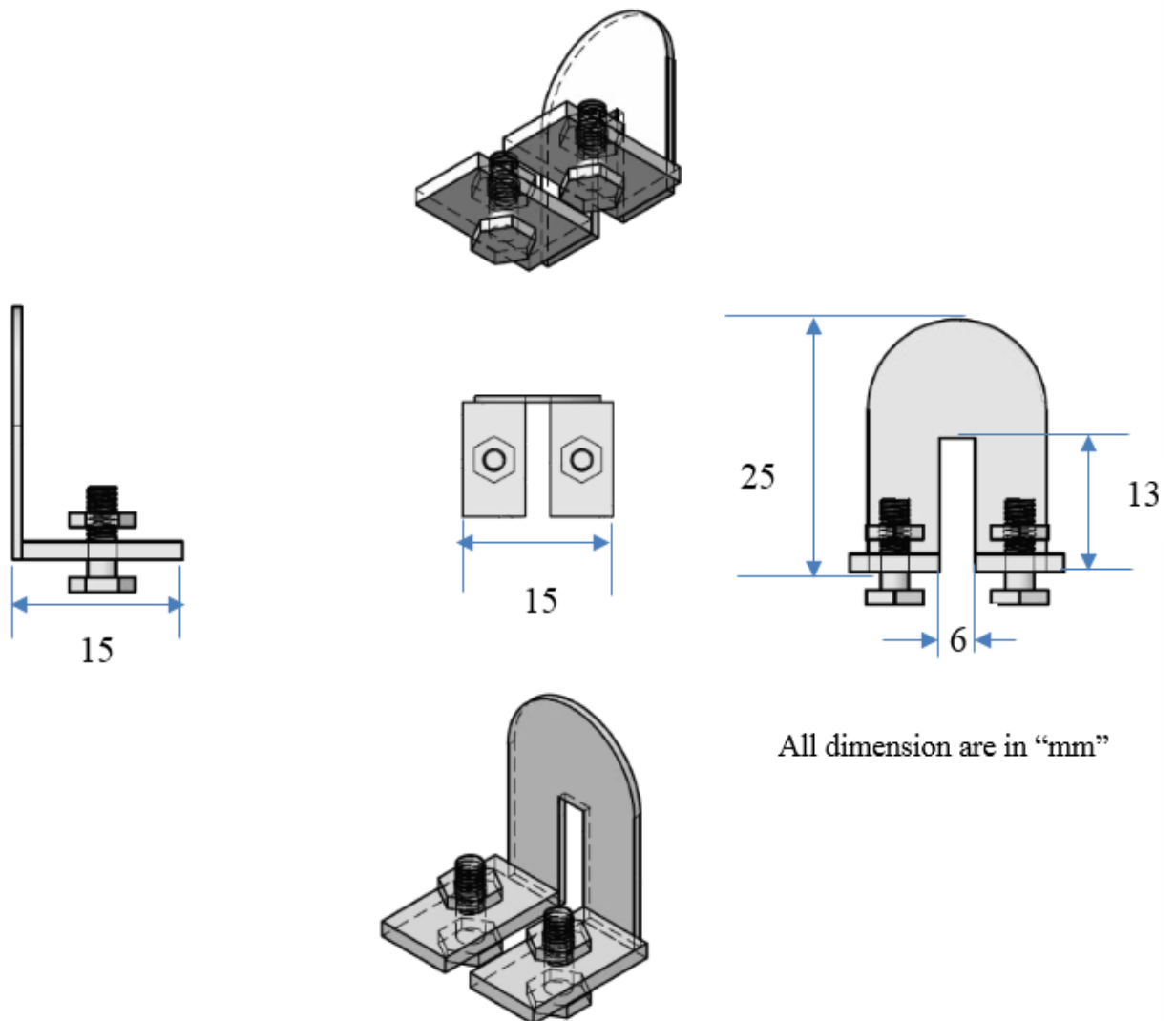

Fig 4.6 Different angle view of pusher

Height and width of the pusher is 25 mm and 15 mm respectively. A section of 13×6 mm is cut from middle of this pusher plate to accommodate the slitting blades.

The pusher is fixed on the two belts using two sets of nut bolts. Distance between two pushers is 210 mm. All the dimensions are chosen according to maximum and minimum value of physical properties that are shown in Table 4.1.

4.3.2.4 Guiding channel

Guiding channel (Fig 4.9) is used for guiding the unpeeled banana on to peeling mechanism. It consists of two rollers and a channel. Guide rollers are fixed to frame with the help of supporting shaft. To maintain the distance of the canvas belt along the path, two guide rollers are fitted along the path of conveying canvas belt. The diameter of the roller shaft is 20 mm and inside diameter of the roller pipe is 22 mm. To reduce friction between the shaft and rolling pipe, grease is applied at all contacts points. Dimensions and respective position of rollers are as shown in Fig 4.7.

Two vertical plates (Fig 4.8 and 4.9) are fitted over the surface of the belts. These work as the guiding channel and also gives support and provides proper direction to the banana piece. The design data for channel dimension is taken from Table 4.1 and is based on maximum diameter of unpeeled banana. If the size of the banana varies, the guiding channel also has a mechanism which can adjust it manually. There are nuts and bolts provided with plates with which space between two plates can be adjusted as shown in Fig 4.8.

4.3.2.5 Slitting unit

The slitting unit consists of two blades made of hardened steel (0.5 mm). The blades are placed at the upper and lower side of the guiding channel, which designed in such a way that two slits are made in the peel. The blade position can be adjusted depending on thickness of banana fruit.

The upper blade is 150 mm in length and 24 mm in width and lower blade is 60 mm in length and 24 mm in width. Both the blade have longitudinal slots by which the depth of the cut can be adjusted. Both the blade are attached to the frame with suitable supports.

4.3.2.6 Pulp collection channel

Pulp (peeled banana) is collected with the help of a collection channel as shown in the Fig 4.1. Peeling unit separates the peels from the hard pulp. The collector is provided at the end of machine. The pulp collector is fabricated using 16 gauge G.I. sheet, in curved channel shape as shown in Fig 4.1. Collector is mounted near the belt end. The overall dimension of collector is 235.2 mm × 95 mm.

4.3.3 Design of peeling unit and its components

4.3.3.1 Telescopic Channel

The telescopic channel consist of two main units namely roller pin unit and separating bar unit, both mounted on the telescopic channel with pins. The commercial available roller channels of 43×15 mm has been used. The telescopic channel is placed above 101 mm from top surface of the machine (Fig 4.7). The telescopic channel two M.S. flat channels with metal balls at the side making the channels to move very smooth. The whole assembly adjust itself according to the size of the banana pieces, with the help of a spring described in the following section.

4.3.3.2 Rollers and pins

Two equal size rollers 100 mm length and 50 mm diameter made up of mild steel are placed on telescopic channel. Ball bearings are fitted on the inner side of the rollers for smooth rotating movement over the surface of banana

pieces. The rollers are mounted on specially designed pins. The diameter of each pin is 20 mm at the bottom side and 15 mm at top side of the roller. The whole rollers and pin assembly is placed 40 mm above the telescopic channel as shown in Fig 4.7.

4.3.3.3 Spring

Springs are made up of hardened steel material. In banana peeling machine, two springs are used. One is placed above and other is placed below the rollers for reducing the vibration as shown in Fig 4.7. The thickness and outer diameter (OD) of springs have been chosen so the pressure exerted on the banana fruit is neither too less causing slippage or too excessive causing squeezing and restricting the movement of the fruit forward. Thickness and OD of springs are 1.2 mm and 14 mm. The springs are articulated with two rollers in peeling unit, when the pieces of banana passes through the rollers, both rollers adjusts the clearance between them automatically with the help of this two springs.

4.3.3.4 Separating unit

Separating unit is mounted over the telescopic channel. Whole unit consist of separating bar assembly, sockets of separating bars, nuts and bolts. Separating bar consist of two specially designed nibs mounted on bars as shown in Fig 4.7., with enough strength to sustain the load of banana while separating the peel. The clearance between the separating bar and roller is adjustable. As per the design data taken on the basis of thickness of peel (Table 4.1) the distance can be adjusted between 2-6 mm. The separating bar penetrates between peel and flesh of fruit and removes the peel. Separating bars are fitted inside the space of socket. Banana fruits are irregular in length, size, shape and curvature and hence separating unit has a benefit that the unit adjusts itself according to the size of banana, keeping the thickness constant.

Distance of separating unit from telescopic channel is 130 mm and diameter of bolts are 15 mm. Diameter of scrapping bars are 7 mm. Diameter and length of sockets are selected according to the dimensions of scraping bars, so that the scraping bar could have enough strength to sustain the load of banana while separating the peel. Diameter and length of the socket are 25 mm and 25 mm, respectively and diameter of socket hole is chosen to be 10 mm.

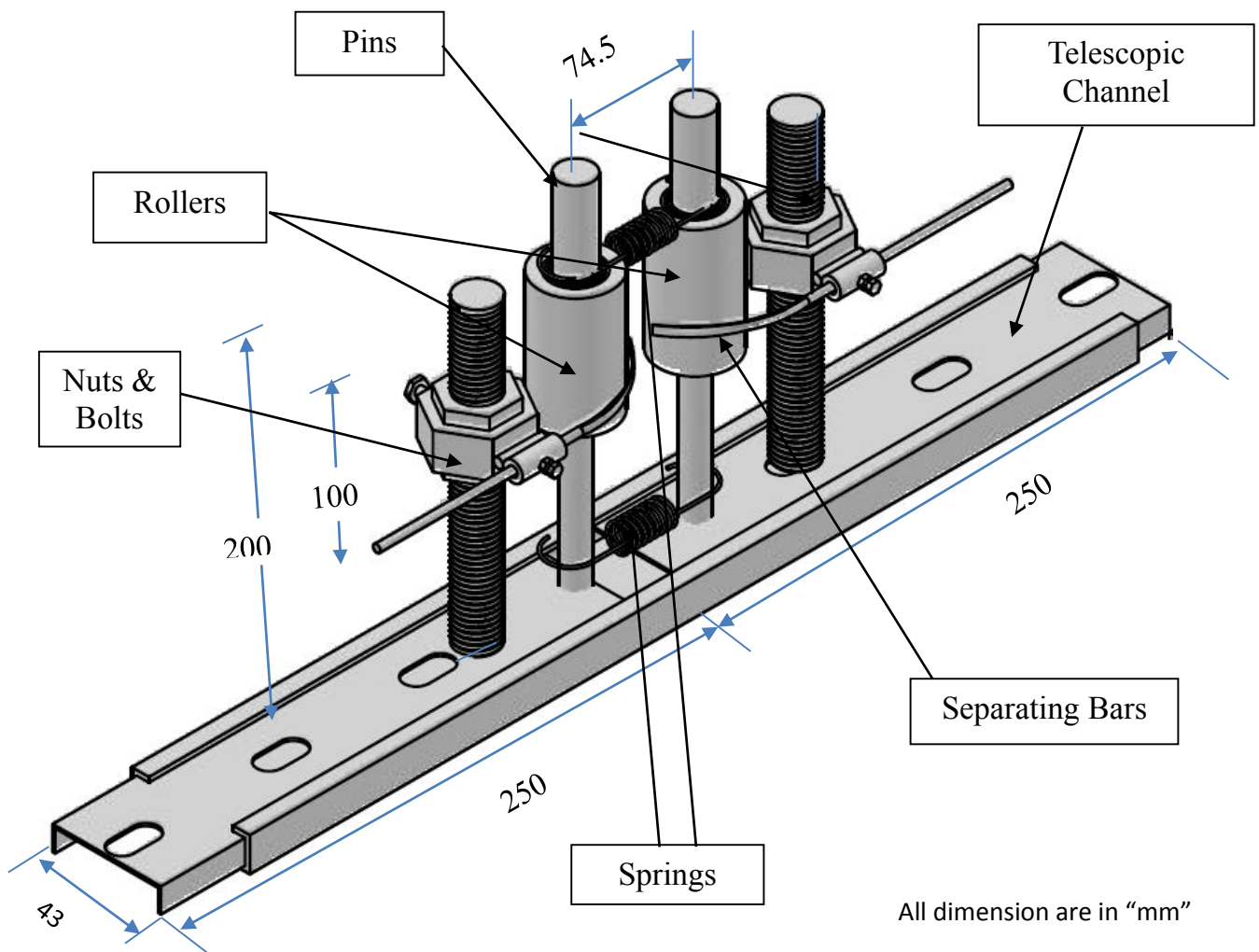

Fig 4.7 Isometric view of peeling unit

4.3.4 Design of power transmission unit and its components

The power transmission unit consist of 3-hp three-phase AC electric motor along with variable frequency drive (VFD), belt drive, vertical rotating pulleys and flat belt conveyor. Drive from motor is transmitted to vertical rotating pulley through simple V-belts. V-belts of type: B-73 is used for power transmission. The speed of machine can be varied with the help of variable frequency drive (VFD).

The motor is placed on the sliding platform at the bottom of the frame (Fig 4.2) in order to achieve the belt tightness as per requirement. The driven pulley is also placed on another sliding platform to achieve the belt tightness. The rpm of motor rotating at 2800 rpm is reduced to 700 rpm on the drive pulley using a 50 mm V belt pulley. The same rpm is transferred to the driven pulley. The driven pulley is fixed on the shaft having the flat belt pulley of 150 mm. The final rpm of the flat belt pulley is 466 rpm. This rpm is controlled using a VFD between 27-75 rpm for operation of the machine.

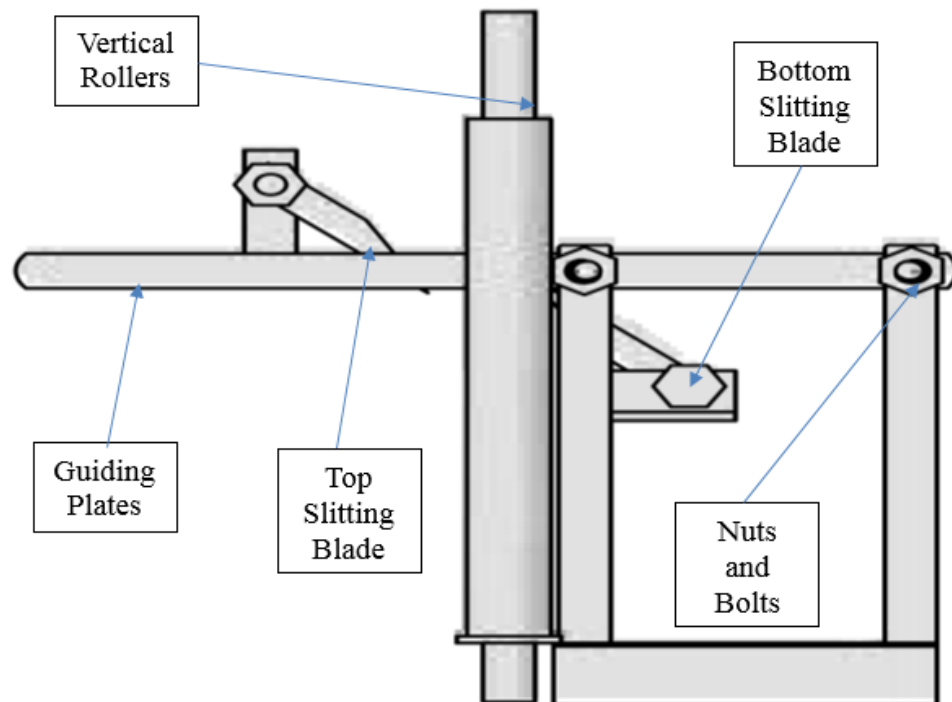

Fig 4.8 Side view of slitting unit

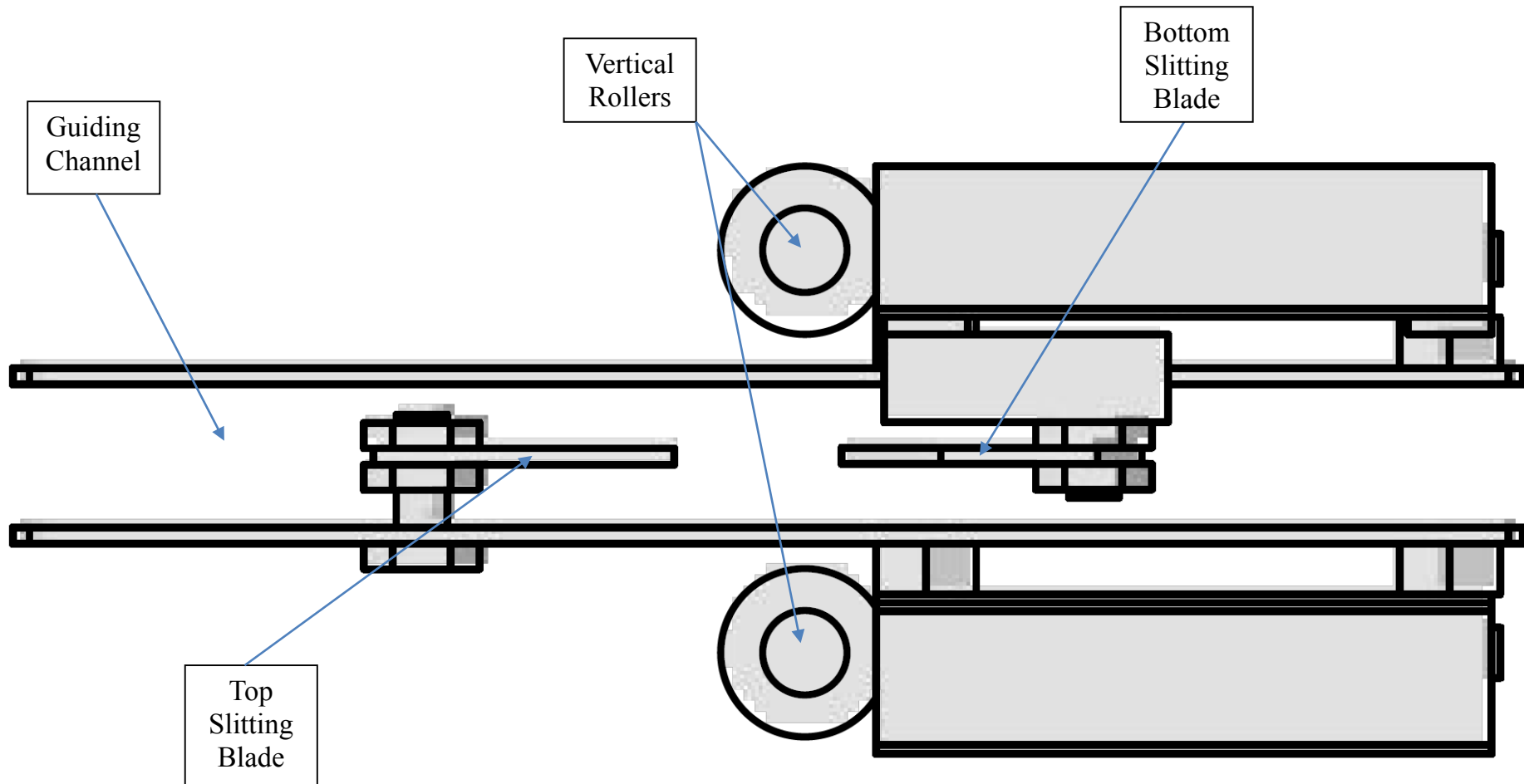

Fig 4.9 Top view of slitting unit



Fig 4.10 Sample preparation for peeling



Fig 4.11 After peeling banana fruit



Fig 4.12 Slitting operation



Fig 4.13 Peeling operation



Fig 4.14 Pusher with belts

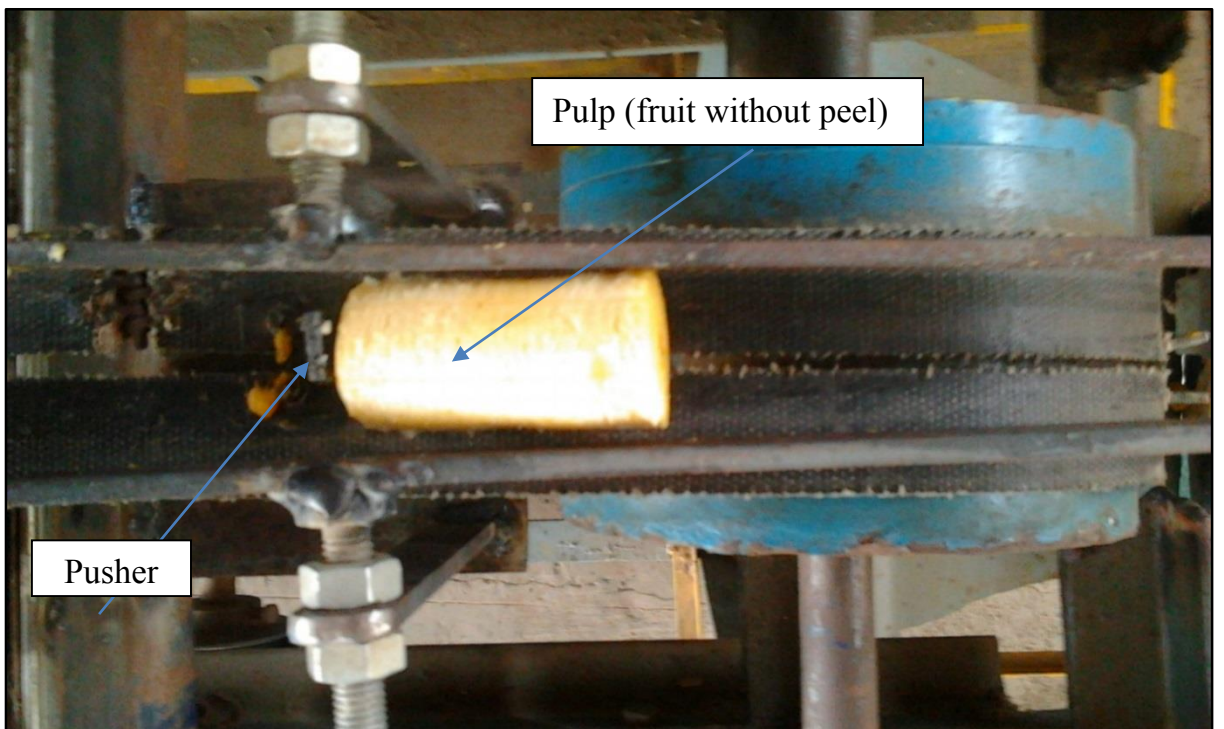

Fig 4.15 After peeling flesh of fruit transferred by pusher

4.4 Performance Evaluation of Banana Peeling Machine

The banana peeling machine was tested and evaluated for semi-ripened banana using speed range (27-75 rpm). Parameters such as operating capacity, peeled (%), unpeeled (%), damage (%), and power consumption were evaluated. It was observed that with increase in rpm, peeling efficiency decreases. The machine operation was very smooth and desirable up to 60 rpm. Thereafter, the machine was vibrating during operation. Sample size of about 2-2.5 kg was used for each trial at designated rpm. The banana was cut into two pieces before experiment.

4.4.1 Percentage of peeled fruits

Observation from the trials was used to evaluate the peeling efficiency for the banana peeling machine. The effect of rpm of pulley on peeling efficiency was studied (Fig 4.16). The peeling efficiency of banana peeling machine was found minimum 75.00 % when machine was operated at speed range of 75 rpm while maximum 96.43 % when machine was operated at 32 rpm (Table 4.2 and 4.3). Below 32 rpm the efficiency was lower and found to be 96.15 %.

From Table 4.2 and 4.3 it was observed that to get higher peeling efficiency and less damage percentage the best operating range of banana peeling machine was 32 rpm. From Fig 4.16 it was observed that peeled percentage of banana peeling machine increased up to 32 rpm and after that it decreased continuously.

4.4.2 Percentage of damage fruits

Minimum and maximum ranges between 3.57 % to 25.00 % when machine was operated at speed of 32 rpm and 75 rpm respectively. From Fig 4.17 it was observed that existing machine gave very good, smooth operation and damage percentage at low rpm and also was concluded that as rpm of machine increased damage percentage of banana increased like wise.

4.4.3 Capacity and feed rate of banana peeling machine

The capacity of the developed power operated banana peeling machine was expressed in two ways viz. feed rate and effective capacity. The feed rate was determined by feeding half cut banana pieces into the banana peeling machine per unit time. Effective capacity of machine is the product of feed rate and peeling efficiency of machine.

From the Table 4.2 and 4.3, it was observed that the minimum and maximum feed rate was 78.19 kg/h at 27 rpm of pulley and 122.84 kg/h at 64 rpm of pulley while effective capacity was 66.78 kg/h and 84.55 kg/h when machine was operated at 54 and 64 rpm of pulley.

4.4.4 Effect of rpm with respect to VFD reading

The power is transmitted from motor to pulley by means of V belts. The speed of operation was changed with the help of variable frequency drive (VFD). It is observed that as increase in VFD reading there is continuous increase in rpm of horizontal pulley.

As the VFD reading was increasing from 1.3 to 2.2 the rpm of pulley increase of from 27 to 75 respectively.

4.4.5 Effect of rpm of pulley on peeling

Rate of peeling operation directly depends on speed of conveyor, i.e. rpm of canvas belts pulley. With increase in rpm of horizontal pulley there was increase in capacity of the machine. From the Table 4.2 and 4.3. It was observed that capacity of machine increased as speed increased.

Table 4.2 Performance evaluation of banana peeling machine at VFD reading 1.3 - 1.7

No.	Speed (rpm)	Quantity (kg)	No. of Bananas	No. of Half Pieces	Time (sec)	No. of Peeled	No. of Damaged	Peeled (%)	Damage (%)	Effective Capacity (kg/h)	Feed Rate (kg/h)
1	27	2.03	13	26	93	25	1	96.15	3.85	71.83	78.19
2	32	2.08	14	28	89	27	1	96.43	3.57	80.85	84.07
3	37	2.10	14	28	90	26	2	92.86	7.14	77.59	83.90
4	42	2.20	15	30	86	27	3	90.00	10.00	76.34	92.34
5	48	2.04	12	24	81	21	3	87.50	12.50	70.62	90.39

Table 4.3 Performance evaluation of banana peeling machine at VFD reading 1.8 – 2.2

No.	Speed (rpm)	Quantity (kg)	No. of Bananas	No. of Half Pieces	Time (sec)	No. of Peeled	No of Damaged	Peeled (%)	Damage (%)	Effective Capacity (kg/h)	Feed Rate (kg/h)
6	54	2.09	13	26	81	22	4	84.62	15.38	66.78	92.89
7	59	2.08	14	28	68	23	5	82.14	17.86	81.04	109.54
8	64	2.29	15	30	67	25	5	83.33	16.67	84.55	122.74
9	70	2.03	12	24	65	19	5	79.17	20.83	73.67	113.16
10	75	2.14	14	28	65	21	7	75.00	25.00	74.24	118.07

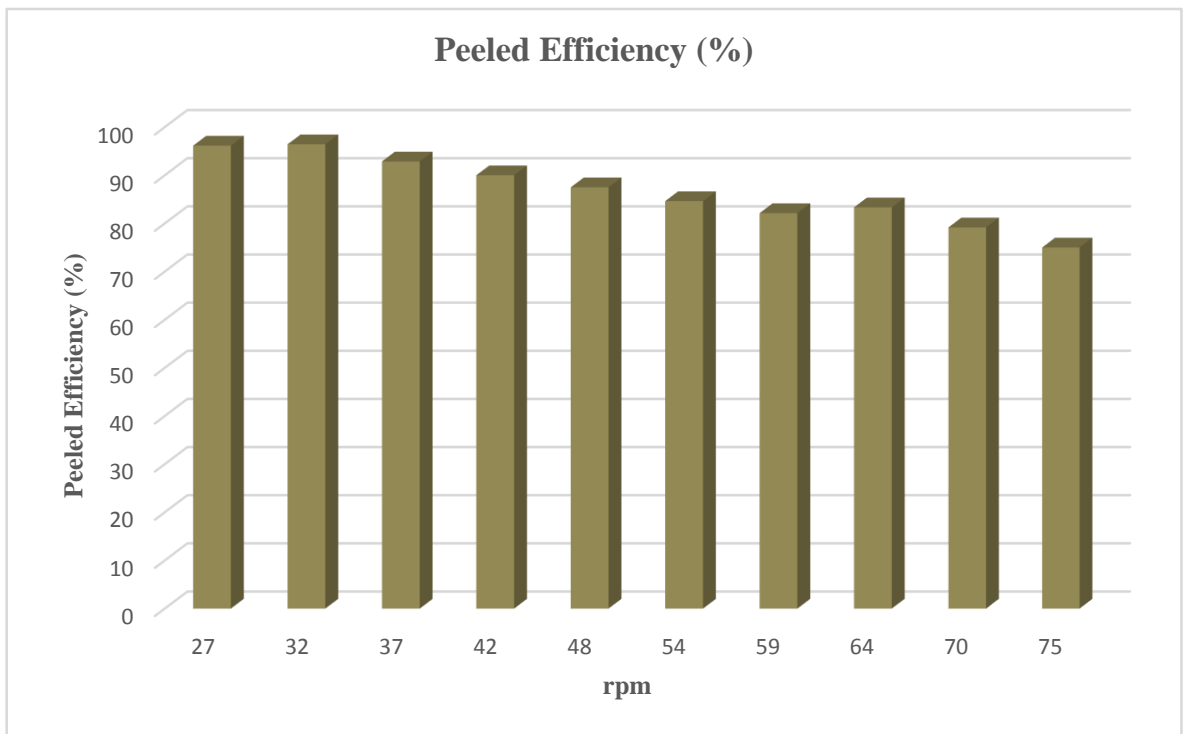

Fig 4.16 Effect of rpm of pulley on peeling efficiency

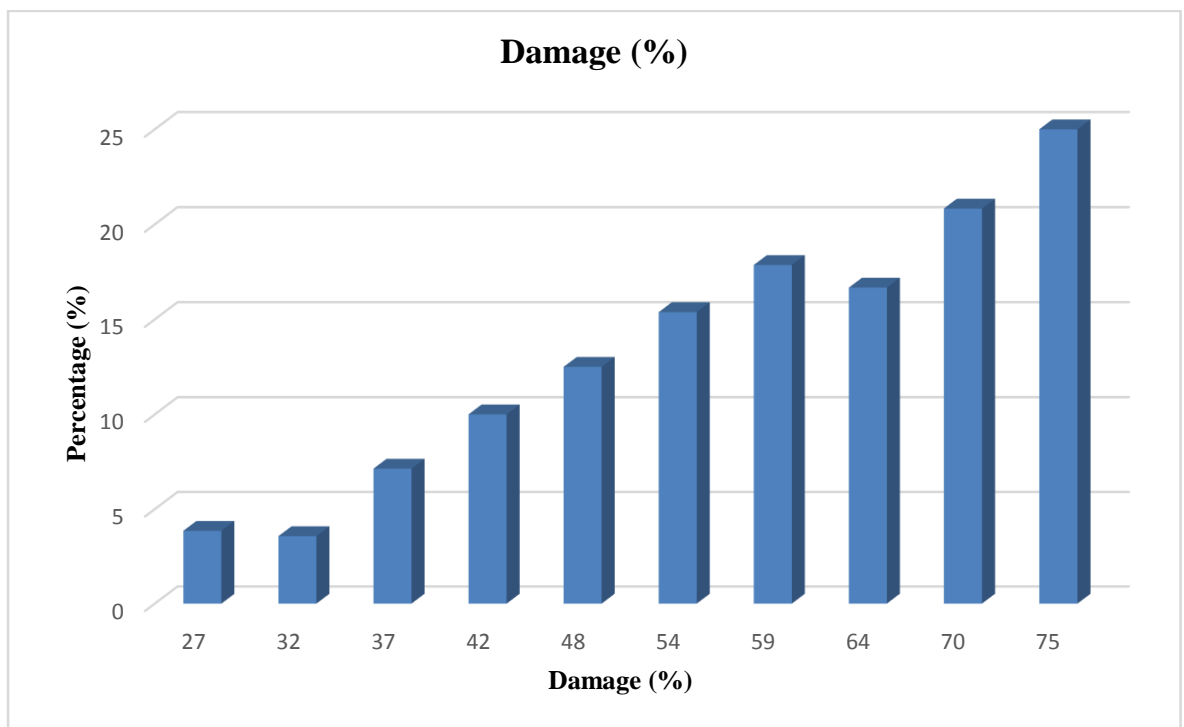

Fig 4.17 Effect of rpm of pulley on damage (%)

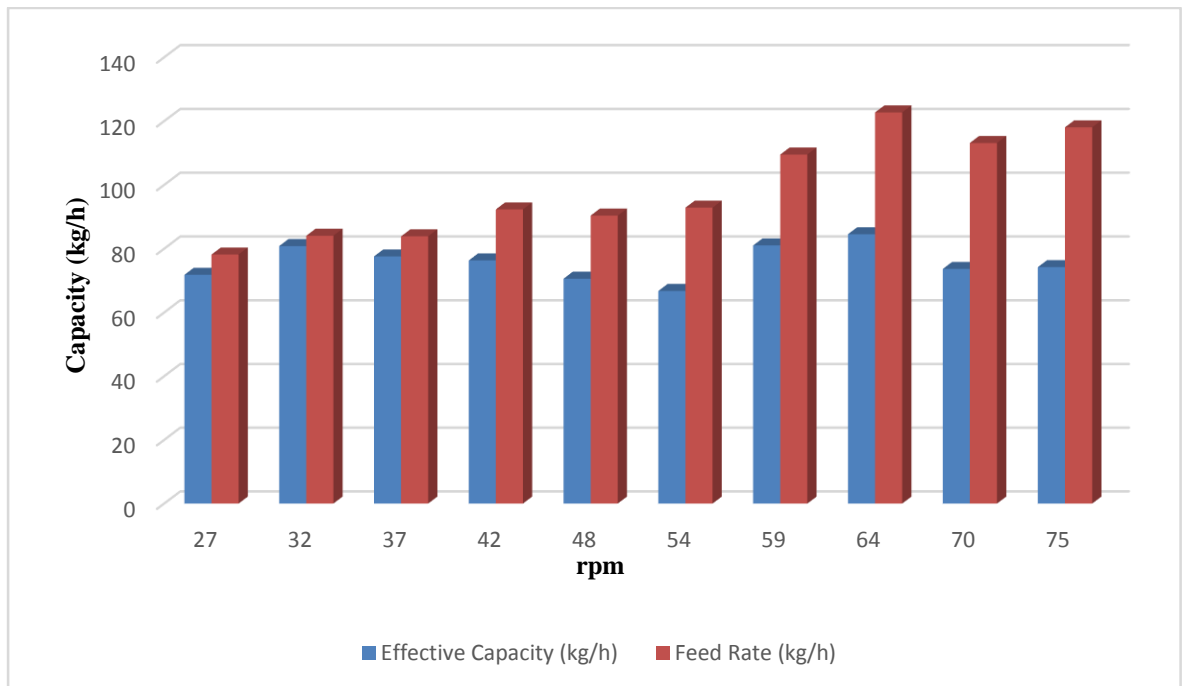

Fig 4.18 Effect on effective capacity and feed rate with respect to rpm of pulley

4.4.6 Power consumption

Power consumption for banana peeler was measured for no load and under load conditions. All calculations for computing the power consumption for banana peeling machine are presented in Appendix A and Appendix-B.

Average power required to operate the machine under no load condition was observed to be 1.43 kW. Average power required to operate the peeling machine was observed to be 2.06 kW. Highest power consumption was observed at 75 rpm pulley for both peeling and no loading condition of machine.

Hence at 32 rpm with a capacity of 87.07 kg/h the total electricity consumption is 1.95 kWh. Therefore with an average electricity cost/kWh of Rs. 7.00 the electricity cost of peeling banana works out to be 0.95 Rs./ kg as shown in Appendix-C.

CHAPTER V

SUMMARY AND CONCLUSIONS

Banana is a commercially important tropical fruit crop in the world trade. Banana is considered to be one of the most important sources of energy in the diet of people living in tropical humid regions. Banana is one of the widely grown and consumed fruits due to their distinct aroma and taste, in all parts of the world. It is the staple food and economic life line for many countries. It is cheap source of carbohydrate and rich source of potassium, calcium, antioxidants and other micronutrients. India is the largest producer of banana and plantains in the world with a production of 16.82 million tonnes from an area of 0.49 million ha. The major banana producing states are Maharashtra, Kerala, Tamilnadu, Gujarat, Bihar, West Bengal, Assam, Andhra Pradesh and Karnataka.

Peeling is the primary and most important operation in banana product processing, mainly in banana chips and wafers processing. Even today, peeling of banana for making chips/wafer is done manually, using stainless steel scouring knives. However, peeling by hand is a relatively slow operation and involves substantial labour when a large number of peeled bananas are desired. Manual peeling is not only tedious and time consuming, but is also difficult to manage because of labour scarcity and maintaining hygiene. Thus, the time and expense in preparing the bananas in this manner has somewhat limited the full commercial development of the product. Mechanised banana peeling is related to the automatic removal of the peel from the fruit of a banana.

A banana peeling machine was earlier designed and fabricated at the College of Food Processing Technology and Bioenergy, AAU, Anand, to peel the banana by considering basic data of physical and mechanical properties of banana fruit. But it is found that the peeling mechanism caused considerable damage to the flesh of the fruit. Hence, this machine needed

modification to reduce the damage to peeled fruit. The research work is proposed with the following specific objectives.

1. To modify the developed banana peeling machine to improve its performance.
2. To design an effective mechanism for feeding, guiding and maintaining depth of peeling for reduction in fruit damage.
3. To evaluate the performance of the modified banana peeling machine for different size of banana fruits.

After modification various physical raw banana variety named *Robusta*, were used to peeling.

The whole machine was divided into four units named by frame, conveying unit, peeling unit and power transmission unit. In which conveying unit consist of main components like (i) belts and pulleys (ii) belts support plate (iii) pusher (iv) guiding channel (v) slitting unit (vi) pulp collection channel. The second most important unit of modified banana peeling machine was peeling unit, consist of (i) telescopic channel (ii) roller and pins (iii) spring (iv) separating unit. The power transmission unit consists of (i) electric motor (ii) variable frequency drive.

By considering the physical and engineering properties of banana, the machine and its components were designed, and fabricated. Banana peeling machine was evaluated for its performance with regards to its operating capacity, effective capacity, peeled efficiency, damage percentage, power consumption etc.

Based on the results, the following conclusions could be drawn.

1. The average respective values of weight, effective length of fruit were 93.64 g and 133.30 mm respectively for *Robusta* variety. The average diameter of banana and thickness of peel at top, middle and bottom of *Robusta* variety from 31.60, 33.01 and 30.20 mm

respectively. The average thickness of peel at top, middle and bottom of Robusta variety from 3.72, 3.97 and 4.02 mm respectively. The average diameter of banana without peel at top, middle and bottom of Robusta variety from 24.16, 25.06 and 22.65 mm respectively.

2. Banana peeling machine was designed conceptualized by combination of gripping, slitting and scrapping mechanisms.
3. The maximum and minimum feed rate of banana peeling machine were observed 118.07 kg/hr at 75 rpm and 78.19 kg/hr at 27 rpm respectively. The maximum and minimum effective capacity of banana peeling machine were observed 84.55 kg/hr at 64 rpm and 66.78 kg/hr at 54 rpm respectively. The peeling efficiency of machine increased as rpm of horizontal pulley increased up to 32 rpm, after these peeling efficiency of machine decreased.
4. The peeled efficiency of the machine was found to be minimum 75.00 % at 75 rpm and maximum 96.43 % at 32 rpm.
5. The maximum and minimum damage percent of banana peeling machine were observed to be 25.00 % at 75 rpm and 3.57 % at 32 rpm respectively.
6. Average power required to operate the machine under no loading condition was observed to be 1.43 kW while average power required for operating peeling machine was 2.06 kW.
7. Operating cost of banana was found 0.95 Rs./kg.

CHAPTER VI

REFERENCES

Anaiboni, E. L. (2003). Plantain peeler, US Patent - 6,591,742,B1. (www.patentstorm.us).

Anonymous (1993). Project profile of Banana processing, SSB Handbook of Export Oriented food Processing projects, CFTRI, 469-470.

Aparicio, S., Sonia G. S., Apolonio, V. T., Juscelino, T., Tania, E. A. and Luis, A. B. (2005). Slowly digestible cookies prepared from resistant starch-rich lintnerized banana starch. *Journal of Food Composition and Analysis*, 20: 75–181.

Aurore, G., Parfait, B. and Fahrasmane, L. (2009). Banana raw materials for making processed food Products. *Trends in Food Science and Technology*, 20: 78-91.

Boyce (1962). Pears peeling machine, US Patent - 45,162. (www.patentstorm.us).

Casey, M. J. (1927). Design and developed pears peeling machine, US Patent – 2,41,880. (www.patentstorm.us).

Deneo, P. H., Stefani, D. E. and Ronco, A. (1996). Vegetables, fruits, and risk of colorectal cancer: a case-control study from Uruguay. *Nutrition & Cancer*, 25(3): 297–304.

Ganachari, A., Thangavel, K., Mazara ali, S., Nidoni, U. and Ananthacharya (2010). Physical properties of **Aonla** fruit relevant to the design of processing equipments. *International Journal of Engineering Science and Technology*, 2(12): 7562-7566.

- Gonzalvo, J. P., Pelanar, S. L. and Castell, A. D. (1992). Perfected machine for peeling orange and similar fruits. US Patent - 5,105, 735. . (www.patentstorm.us).
- Harvey, J. G. and Joseph, R. A. (1967). Apparatus for and method of removing pulp from a banana, US Patent-670,946. (www.patentstorm.us).
- Ishikawa, S. (1988). Design fruit and vegetable peeling machine, US Patent – 47,71,682. (www.patentstorm.us).
- Jackson, J. C., Bourne, M. C. and Barnard, J. (1996). Optimization of blanching for crispness of banana chips using response surface methodology. *Journal of Food Science*, 61(1): 165-166.
- John, E. P. and Granada, H. C. (1970). Method and apparatus for peeling banana, US Patent-3627011. (www.patentstorm.us).
- Kachru, R. P., Kotwaliwale, N. and Balasubramanian, D. (1995). Physical and mechanical properties of green banana (*Musa paradisiacal*) fruit. *Journal of Food Engineering*, 26 (3): 369-378.
- Kachru, R. P., Balasubramanian, D. and Kotwaliwale, N. (1996). Design, development and evaluation of rotary slicer for raw banana chips. *Journal of Agricultural Mechanization in Asia, Africa and Latin America (JPN)*, 27 (4): 61-64.
- Kajuna, S., Bilanski, W. K. and Mittal, G. S. (1997). Textural changes of banana and plantain pulp during ripening. *Journal of Science Food Agric*, 75(8): 244-250.
- Lenscott, F. R. (2004). Green banana/Plantain safety peeler, US Patent - 66,719,642. (www.patentstorm.us).

- Leslie, B. (1984). Banana peeling machine, US Patent- 420,906. (www.patentstorm.us).
- Liggins, J., Bluck, L. J. C., Runswick, C., Atkinson, C., Coward, W. A., and Bingham, S. A. (2000). Daidzein and genistein content of vegetables. , *Brit. J. Nutrition*, 84(1): 717-725.
- Mandhar, S. C. and Kumaran, G. S. (1999). Development of a continuous motorized peeler for raw mangoes. *Journal of Food Science Technology*, 32(1): 65-67.
- Mohapatra, D., Mishra, S. and Meda, V. (2009). Plantains and their postharvest uses: An overview. *Stewart Postharvest review*, 5(5): 1-11.
- Mohapatra, D., Mishra, S. and Sutar, N. (2010). Banana and its by-product utilization: an overview. *Journal of Scientific and Industrial Research*, 69(5): 323-329.
- Mohapatra, D., Mishra, S. and Sutar, N. (2010). Banana post harvest practices: current status and future prospects. *Agricultural Reviews*, 31(1): 56-62.
- Molla, M. M., Nasrin, T. A. A. and Islam, M. N. (2009). Study on the suitability of banana varieties in relation to preparation of chips. *Journal of Agriculture & Rural Development*, 7(2): 81-86.
- Mohsenin N N (1980). Thermal Properties of Foods and Agricultural Materials. *Journal of Engineering of Food Processing Systems*, 83(5): 121.

- Mwonga, J. H., Ramteke R. S. and Eipeson, W. E. (2001). Predehydration steaming changes physicochemical properties of unripe banana flour. *Journal of Food Processing and Preservation*, 25(4): 35-47.
- Nelson, S. C.; Ploetz, R. C. and Kepler, A. K. (2006). Species profiles for Pacific Island agroforestry. Available at <http://www.traditionaltree.org/> (January 27, 2014).
- Pawar, K. R. (2011). Design and development of banana peeling machine, unpublished M.Tech. thesis, Anand Agricultural University, Anand.
- Ploetz, R.C., Kepler, A. K., Daniells, J. and Nelson, S. C. (2007). Banana and plantain: An overview with emphasis on Pacific Island cultivars. *Pacific Island Agroforestry*, 28 (11): 1024-1026.
- Ralph, P. (1969). Banana peeler, US Patent - 3,451,55. (www.patentstorm.us).
- Rafael, A. L. A., Raul, F., Ilya, I., Jose, T. M., Luis, G. B. M., Elena, N., Andrey, P., Julio, S., Julio, V. and James, H. W. (2007). Method for separating banana pulp from its peel, and a device for the implementation of this method, US 2007/0122534 A1. (www.patentstorm.us).
- Rodriguez (1927). Design manual operated green banana/plaintain peeler, US Patent – 54,97,552. (www.patentstorm.us).
- Saravacos, G. D. and Kostaropoulos, A. E. (2006). Handbook of food processing equipment. Springer Private Limited. New Delhi.
- Sleeper, N. M. (1927). Method and apparatus for peeling banana, US Patent - 203736. (www.patentstorm.us).

Sonawane, S. P. (1997). Development of power operated raw banana slicer for small scale processing unit, unpublished M.Tech. Thesis, Dr. BSKKV, Dapoli.

Sonawane, S. P., Sharma G. P. and Pandya, A. C. (2011). Design and development of power operated banana slicer for small scale food processing industries. *Res. Agr. Eng.*, 57: 144–152.

Usher, H. and Abbot, P. (1988). A history of mechanical inventions. *Courier Dover*, 486(11): 300-305.

APPENDIES

Appendix-A: Power consumption no-load condition of banana peeling machine

rpm	V	A	cos ϕ	$P = \sqrt{3}VI \cos \phi$ (kW)
27	415	2.3	0.85	1.40
32	415	2.3	0.85	1.40
37	415	2.3	0.85	1.40
42	415	2.3	0.85	1.40
48	415	2.3	0.85	1.40
54	415	2.3	0.85	1.40
59	415	2.4	0.85	1.47
64	415	2.4	0.85	1.47
70	415	2.4	0.85	1.47
75	415	2.5	0.85	1.52
Average				1.43

Appendix-B: Power consumption under load condition of banana peeling machine

Rpm	V	A	cos ϕ	$P = \sqrt{3}VI \cos \phi$ (kW)
27	415	3.2	0.85	1.95
32	415	3.2	0.85	1.95
37	415	3.2	0.85	1.95
42	415	3.3	0.85	2.01
48	415	3.3	0.85	2.01
54	415	3.4	0.85	2.08
59	415	3.4	0.85	2.08
64	415	3.5	0.85	2.14
70	415	3.6	0.85	2.20
75	415	3.7	0.85	2.26
Average				2.06

Appendix-C: Cost economics for peeling of banana

Electricity cost

Rate of electricity cost per unit = 7 Rs./-

Total power consumption at 32 rpm = 1.95 kw/h

Total electricity cost per hour = 1.95×7
= 13.65 Rs./h

Man power cost

3 person required for peeling operation each cost = 170 Rs./day/8h

Man power cost per hour = 63.75 Rs./ h

Maintenance cost other cost per hour = 5 Rs./h

Capacity of the machine at 32 rpm = 72.35 kg/h

Total operating cost with load condition = $13.65 + 63.75 + 5$
= 82.4 Rs./ h

Operating cost of 1 kg banana = $82.4/87.07$
= 0.95 Rs./ kg

Appendix-D: Physical properties of banana

No.	Effective Length (mm)	Weight (g)	Weight of pulp (g)	Weight of peel (g)	Pulp to peel ratio	Diameter of banana with peel (mm)			Thickness of peel (mm)			Diameter of banana without peel (mm)		
						A	B	C	A	B	C	A	B	C
1	132.9	93.45	65.42	28.04	2.33	31.64	33.05	30.24	3.73	3.98	4.03	24.18	25.09	22.67
2	134	94.11	67.76	26.35	2.57	31.60	33.01	30.20	3.72	3.97	4.02	24.16	25.06	22.65
3	140	98.87	69.21	29.66	2.33	31.78	33.19	30.37	3.76	4.01	4.06	24.26	25.17	22.74
4	142	101.98	69.35	32.63	2.13	32.32	33.75	30.88	3.88	4.13	4.18	24.55	25.49	23.02
5	131.4	93.47	69.17	24.30	2.85	32.01	33.43	30.59	3.81	4.06	4.11	24.38	25.31	22.86
6	131.1	93.78	72.21	21.57	3.35	32.19	33.62	30.76	3.85	4.10	4.15	24.48	25.41	22.95
7	132.2	92.98	69.74	23.25	3.00	31.65	33.06	30.24	3.73	3.98	4.03	24.18	25.09	22.68
8	133.1	94.48	68.97	25.51	2.70	31.94	33.36	30.52	3.80	4.05	4.10	24.35	25.27	22.83
9	133.2	94.49	71.81	22.68	3.17	31.92	33.34	30.50	3.79	4.04	4.09	24.33	25.25	22.82
10	141.1	99.98	74.99	25.00	3.00	31.89	33.30	30.47	3.79	4.04	4.09	24.31	25.23	22.80

No.	Effective Length (mm)	Weight (g)	Weight of pulp (g)	Weight of peel (g)	Pulp to peel ratio	Diameter of banana with peel (mm)			Thickness of peel (mm)			Diameter of banana without peel (mm)		
						A	B	C	A	B	C	A	B	C
11	136.7	95.23	24.76	31.35	2.85	31.35	32.74	29.96	3.67	3.92	3.97	24.02	24.91	22.52
12	135.2	95.13	26.64	31.66	2.57	31.66	33.07	30.26	3.74	3.99	4.04	24.19	25.10	22.68
13	139.8	97.44	24.36	31.36	3.00	31.36	32.76	29.97	3.67	3.92	3.97	24.02	24.92	22.53
14	129.4	90.11	19.82	31.34	3.55	31.34	32.73	29.94	3.66	3.91	3.96	24.01	24.90	22.52
15	128.9	84.17	17.68	29.38	3.76	29.38	30.69	28.08	3.23	3.48	3.53	22.92	23.73	21.52
16	130	91.47	22.87	31.66	3.00	31.66	33.07	30.26	3.74	3.99	4.04	24.19	25.10	22.68
17	136.7	96.11	25.95	31.64	2.70	31.64	33.04	30.23	3.73	3.98	4.03	24.18	25.08	22.67
18	127.8	87.44	22.73	30.79	2.85	30.79	32.16	29.42	3.54	3.79	3.84	23.70	24.57	22.24
19	126.9	86.86	23.45	30.80	2.70	30.80	32.17	29.43	3.54	3.79	3.84	23.71	24.58	22.24
20	127.2	89.41	21.46	31.63	3.17	31.63	33.04	30.23	3.73	3.98	4.03	24.17	25.08	22.67

No.	Effective Length (mm)	Weight (g)	Weight of pulp (g)	Weight of peel (g)	Pulp to peel ratio	Diameter of banana with peel (mm)			Thickness of peel (mm)			Diameter of banana without peel (mm)		
						A	B	C	A	B	C	A	B	C
21	140.9	97.57	68.30	29.27	2.33	31.16	32.55	29.78	3.62	3.87	3.92	23.91	24.80	22.43
22	142.2	99.87	66.91	32.96	2.03	31.60	33.01	30.20	3.72	3.97	4.02	24.16	25.06	22.65
23	141.3	98.76	70.12	28.64	2.45	31.45	32.85	30.05	3.69	3.94	3.99	24.07	24.97	22.58
24	139.7	99.15	71.39	27.76	2.57	31.94	33.36	30.52	3.80	4.05	4.10	24.34	25.26	22.82
25	139.6	96.44	68.47	27.97	2.45	31.09	32.47	29.71	3.61	3.86	3.91	23.87	24.75	22.39
26	141.1	103.1	71.14	31.96	2.23	32.88	34.34	31.42	4.01	4.26	4.31	24.87	25.83	23.31
27	139	97.11	73.32	23.79	3.08	31.44	32.84	30.04	3.69	3.94	3.99	24.07	24.96	22.57
28	136.9	96.08	74.94	21.14	3.55	31.58	32.99	30.18	3.72	3.97	4.02	24.15	25.05	22.64
29	138.4	97.78	72.94	24.84	2.94	31.79	33.21	30.38	3.77	4.02	4.07	24.26	25.18	22.75
30	137.9	98.44	70.19	28.25	2.48	32.12	33.55	30.70	3.84	4.09	4.14	24.45	25.37	22.92

No.	Effective Length (mm)	Weight (g)	Weight of pulp (g)	Weight of peel (g)	Pulp to peel ratio	Diameter of banana with peel (mm)			Thickness of peel (mm)			Diameter of banana without peel (mm)		
						A	B	C	A	B	C	A	B	C
31	130.8	93.55	72.97	20.58	3.55	32.18	33.62	30.75	3.85	4.10	4.15	24.48	25.41	22.95
32	128.9	85.67	64.34	21.33	3.02	29.91	31.24	28.58	3.35	3.60	3.65	23.22	24.04	21.79
33	127.6	90.89	67.62	23.27	2.91	32.05	33.48	30.63	3.82	4.07	4.12	24.41	25.33	22.88
34	125.5	85.11	64.43	20.68	3.12	30.52	31.87	29.16	3.48	3.73	3.78	23.55	24.41	22.10
35	124.5	85.17	65.07	20.10	3.24	30.78	32.15	29.42	3.54	3.79	3.84	23.70	24.57	22.23
36	121.3	83.14	64.85	18.29	3.55	30.84	32.21	29.47	3.55	3.80	3.85	23.74	24.61	22.26
37	130	92.89	69.30	23.59	2.94	32.15	33.58	30.73	3.85	4.10	4.15	24.46	25.39	22.93
38	121.1	85.47	60.94	24.53	2.48	31.76	33.17	30.35	3.76	4.01	4.06	24.24	25.16	22.73
39	133.2	94.34	73.59	20.75	3.55	31.87	33.29	30.46	3.78	4.03	4.08	24.31	25.22	22.79
40	123.2	86.14	64.69	21.45	3.02	31.46	32.86	30.07	3.69	3.94	3.99	24.08	24.98	22.58

No.	Effective Length (mm)	Weight (g)	Weight of pulp (g)	Weight of peel (g)	Pulp to peel ratio	Diameter of banana with peel (mm)			Thickness of peel (mm)			Diameter of banana without peel (mm)		
						A	B	C	A	B	C	A	B	C
41	134.7	95.52	66.86	28.66	2.33	31.91	33.33	30.49	3.79	4.04	4.09	24.33	25.25	22.81
42	136.1	96.44	68.18	28.26	2.41	31.89	33.30	30.47	3.79	4.04	4.09	24.31	25.23	22.80
43	136.9	95.97	68.43	27.54	2.48	31.55	32.95	30.14	3.71	3.96	4.01	24.13	25.03	22.62
44	134.7	94.93	72.15	22.78	3.17	31.71	33.12	30.30	3.75	4.00	4.05	24.22	25.13	22.71
45	135.4	95.79	71.46	24.33	2.94	31.84	33.25	30.42	3.77	4.02	4.07	24.29	25.20	22.77
46	130.8	92.11	65.67	26.44	2.48	31.69	33.10	30.28	3.74	3.99	4.04	24.21	25.11	22.70
47	131	93.44	72.88	20.56	3.55	32.10	33.52	30.67	3.83	4.08	4.13	24.43	25.36	22.91
48	130.4	93.04	69.87	23.17	3.02	32.11	33.53	30.68	3.83	4.08	4.13	24.44	25.36	22.91
49	130.9	93	69.19	23.81	2.91	31.97	33.39	30.55	3.80	4.05	4.10	24.36	25.28	22.84
50	131.6	94.011	68.91	25.10	2.75	32.15	33.58	30.72	3.84	4.09	4.14	24.46	25.39	22.93

Appendix-E: Motor specification

Specification of the motor is given below.

kw/HP : 2.2 kw / 3HP

Current : AC

Type : S1 duty

Speed : 2800 rpm

Volt : 415V

Field Amperes : 4.5A

Mfd. By : Jyoti Ltd., Baroda, India

Appendix-F: VFD specification

Input : 3-PH, 380-480 V, 50/60 Hz, 7.1 A

kw/HP : 2.2 kw / 3 HP

Output : 3-PH, 0-480V, 5.5A, 4.4KVA

Frequency range : 0.1-600 Hz

Mfd By : Delta Electronics Inc

Appendix-G: Tachometer specification

Type of display 5 digit, 7 segment bright red LED

Accuracy : $\pm (0.05 \% \pm 1 \text{ digit})$

Range select : automation

Measuring distance : 100 to 300 mm/ 4 to 12 inches

Manufacture : Khera instruments (P) Ltd. Delhi.