

**EFFECT OF LANTANA MULCH ON WATER USE EFFICIENCY
GROWTH AND YIELD OF RAINFED
RABI CROPS**

THESIS

By

HARI RAM NUR

Submitted

to



**HIMACHAL PRADESH KRISHI VISHVA VIDYALAYA
PALAMPUR-176 062 (H. P.)**

In partial fulfilment of the requirements
for the degree of

**MASTER OF SCIENCE IN AGRICULTURE
(AGRONOMY AND AGROMETEOROLOGY)**

1987

UNIVERSITY LIBRARY
H. P. KRISHI VISHVA VIDYALAYA
PALAMPUR

Acc. No. 28727

Class No. 631.7 Book No. N93E

Author Nur Hari Ram

Title Effect of jantana mulch on
water efficiency, growth and
water yield of rainfed Padi crops.

Borrower's No.	Due Date	Borrower's No.	Due Date

P. KRISHNANISHVA VIDYALAYA
Library, PALAMPUR (H.S.S.)
File No. 28727
19.11.87
The Dean, HPRYS, CoA. PLP
Dept. _____
File No. _____ Date _____
Requested by _____ Checked by _____
S. Ram
19/11/87

631.7
N93 E

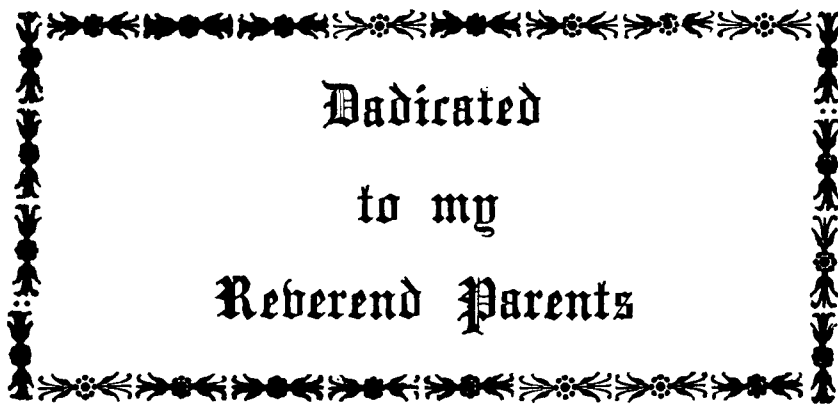
A decorative rectangular border with a repeating floral and leaf pattern, enclosing the central text.

Dedicated
to my
Reverend Parents

CERTIFICATE I

Certified that the thesis entitled, " Effect of lantana mulch on water use efficiency, growth and yield of rainfed kabi crops," submitted in partial fulfilment of the requirements for the award of the degree of Master of Science in Agriculture (Agronomy and Agrometeorology) of the Himachal Pradesh Krishi Vishva Vidyalaya, Palampur is the bonafide research work carried out by Mr. Hari Ram Nur son of Shri Khaikoo Ram under my supervision and that no part of this thesis has been submitted for any other degree.

The assistance and help received during the course of this investigation has been fully acknowledged.

Palampur
Dated: 30.6.87



30.6.87
(I.S. Chakur)
Chairman
Advisory Committee

C E R T I F I C A T E II

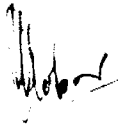
This is to certify that the thesis entitled, " Effect of Lantana mulch on water use efficiency, growth and yield of rainfed rabi crops" submitted by Shri Hari Ram Nur (Admission No. P-85-A-9M in partial fulfilment of the requirements for the degree of M.Sc.(Agri.) has been approved by the Examining Committee after Oral Examination of the same in collaboration with the Co-opted member.

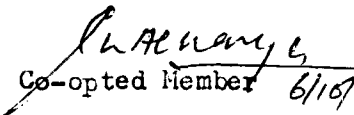

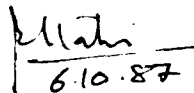
Chairman
Advisory Committee

Co-opted Member 6/10/87

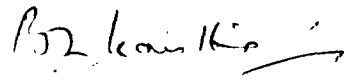
6.10.87
Member

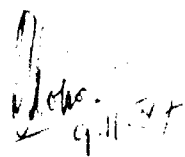
Member

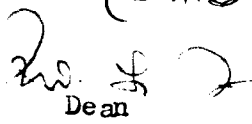
9.11.87
Head of the Department

Member 
(S.K. Srinivas)

Dean 16.11.87
College of Agriculture
Palampur.

ACKNOWLEDGEMENT

I feel it my profound privilege and rare honour in expressing my heartfelt gratitude and sincere thanks to Dr.I.S.Chakor, Head, Department of Agronomy and Agrometeorology, the Chairman of my advisory committee for suggesting me the problem and advising on its methodology, painstaking guidance, valuable suggestions and sustained encouragement throughout the course of this investigation and constructive criticism during the preparation of manuscript.

My primordial obligations deserve extension to the members of my advisory committee, Dr.R.C.Thakur, Associate Professor of Agronomy and Agrometeorology, Dr.B.L.Kaistha, Associate Professor Statistics and Dr.S.K. Sharma, Associate Professor, Regional Research Station Dhaulakuan for their constructive suggestions and inspiration to complete this project.

I also acknowledge the necessary facilities in terms of fields, laboratory and library that were provided to me by the H.F.Krishi Vishva Vidyalaya authorities to enable me to complete my research work in fairly reasonable time.

I express my heartfelt gratitude to Dr.Charanjeet Singh, Director of Agriculture, Himachal Pradesh for granting me study leave and providing opportunity to enable me to complete M.Sc.degree in Agriculture(Agronomy and Agrometeorology).

I also extremely thankful to Mr.B.D.Goma,Project Officer, IADP,Palampur for providing necessary help during the course of this investigation.

Thanks are also due to Dr.C.M.Singh, Dr.C.L.Acharya, Dr.H.L.Shrama, Dr.Bhopal Singh and Dr.R.D.Sood for their valuable suggestions.

I wish to record my heartfelt thanks to my colleagues, Mr.S.S.Rana, Y.P.Thakur, Vidyanath, J.C.Rana, U.R.Cheema and Mrs.Urmil Parmar and friends Krishan, Bhuvnesh, Rakesh, Tilak, Ajeet, Rajinder, Rattan, Jeevan, Ramesh, Pritam, Ambi, Kishan and Kishor, Pritam, P.R.Verma and I.S.Guleria and P.S.Guleria:

for their untiring and gratuitous help rendered during various stages of compilation of the manuscript.

A major acknowledgement remains due to my best friend Suresh Kumar Sharma for his active cooperation at various stages of the completion of this project.

I am thankful to Shri B.S.Rana for typing this manuscript.

I shall remain indebted to my beloved parents and brother-in-law whose guidance, encouragement have always been a beacon light that enabled me to complete my education goals at this place with greater satisfaction.

Last but not the least, I would remiss if I do not mention a few words in appreciation for preservance shown by my wife and children, who spared me to complete this work at their personal comforts and against many odds. I would like to inscribe on record for patient endurance the intimates have exhibited during my study.

Responsibility of any mistake of omission or of commission is however entirely mine.

Palampur

Dated: 30.6.57.

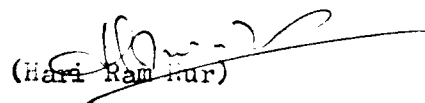
(Hari Ram Kur)

CONTENTS

<u>Sr.no.</u>	<u>Title</u>		<u>Page</u>
1.	INTRODUCTION	1
2.	REVIEW OF LITERATURE	5
	2.1.Effect of mulches on crop growth and development of rainfed rabi crops.		6
	2.2.Effect of mulches on crop yields and water use efficiency		7
	2.3.Effect of mulches on soil properties		10
	2.4.Effect of mulches on moisture depletion by rabi cereals, oilseeds and pulses.		15
	2.5.Economic feasibility of various Rabi crops		19
3.	MATERIAL AND METHODS	22
	3.1. Site		22
	3.2. Weather and climate		22
	3.3. Soil temperature		22
	3.4. Cropping history		23
	3.5. Soil Analysis		23
	3.6. Experimental details		23
	3.7. Field preparation		26
	3.8. Layout		26
	3.9. Fertilizer application		26
	3.10.Sowing		26
	3.11.Application of mulch		27
	3.12.Harvesting and threshing		27
	3.13.Cultural operations		27
	3.14.Biometric observations		28
	3.15.Yield attributes		30
	3.16.Soil Moisture Studies		31
	3.17.Economic Studies		34
	3.18.Statistical analysis		35
4.	EXPERIMENTAL RESULTS	36
	4.1. Growth attributes		36
	4.2. Development stages		38
	4.3. Yield attributes		39
	4.4. Grain and straw yield		40
	4.5. Wheat Equivalent Yield		41
	4.6. Seasonal Crop Water Use Studies		43
	4.7. Depthwise and stagewise per cent soil moisture contribution of different crops		48
	4.8. Crop Water expense Studies		52
	4.9. Soil Chemical Properties		57
	4.10.Water use efficiency		59
	4.11.Economics		60
5.	DISCUSSION	63
6.	SUMMARY AND CONCLUSION	71
	REFERENCES	i - x
	APPENDICES	i - xx

LIST OF MAIN TABLES

<u>Sr.No.</u>	<u>Title</u>	<u>Page</u>
1.	Mechanical and chemical analysis of soil.	24
2.	Cropping history	25
3.	Calender of cultural operations	28
4.1.	Mean treatment effects on growth attributes of crops	36
4.2.	Mean treatment effects on plant height (cm)	37
4.3.	Mean treatment effects on development stages	38
4.4.	Mean treatment effects on yield attributes	39
4.5.	Mean treatment effects on grain and straw yield (q/ha)	41
4.6.	Mean treatment effects on wheat equivalent grain and straw yield	42
4.7.	Mean treatment effect on depthwise and stagewise seasonal water use (cm)-wheat crop.	44
4.8.	Mean treatment effects on depthwise and stagewise seasonal water use (cm) -barley crop.	45
4.9.	Mean treatment effects on depthwise and stagewise seasonal water use (cm) - linseed crop.	46
4.10.	Mean treatment effects on depthwise and stagewise seasonal water use (cm) - mustard crop.	47
4.11.	Mean treatment effects on depthwise and stagewise seasonal water use (cm) - Lentil crop.	48
4.12.	Treatment effects on total water expense during crop growth(cm)	53
4.13.	Treatment effects on monetary return/ha mm water used.	56
4.14.	Mean treatment effects on available N,P and K at harvest (kg/ha)	56
4.15.	Mean treatment effects on water use efficiency of rabi crops(kg/ha cm).	60
4.16.	Treatment effects on gross return, net return and cost benefit ratio (Rs/ha).	60

LIST OF FIGURES

Sr.No.	Title	Between Pages
1.	Mean weekly weather data Rabi 1985-86	22-23
2.A	Weekly mean soil temperature °C	23-24
2.B.	Weekly mean soil temperature °C	23-24
3.	Plan of layout	26-27
4.	Treatment effects on grain and straw yield.	40-41
5.	Treatment effects on wheat equivalent yield of Rabi crops.	41-42
6.	Seasonal water use -wheat crop	43-44
7.	Seasonal water use - barley crop	44-45
8.	Seasonal water use - linseed crop	45-46
9.	Seasonal water use - mustard crop	46-47
10.	Seasonal water use - lentil crop	47-48
11.	Total growth period water use of Rabi crops	53-54
12.	Depthwise seasonal water use(cm) at different crop growth stages- wheat	48-49
13.	Depthwise seasonal water use (cm) at different crop growth stages- barley	49-50
14.	Depthwise seasonal water use (cm) at different crop growth stages- linseed	50-51
15.	Depthwise seasonal water use (cm) at different crop growth stages - mustard	51-52
16.	Depthwise seasonal water use (cm) at different crop growth stages- lentil	52-53
17.	Depthwise cumulative water use at growth stage of rabi crops.	54-55

INTRODUCTION

Chapter 1

INTRODUCTION

The future of humanity lies in the arid and semi-arid lands as the humid and more favourable rainfall areas, have been extensively and intensively cultivated and heavily populated by human beings. During the last about 30 years, the population of India has increased by 90 per cent while the cultivate area has increased only by 20 per cent (Anonymous, 1984). The population pressure is a major driving force behind our quest for high crop yield.

Efficient utilization of water resources is one of the important and crucial factors for agricultural production for meeting the challenge of feeding relentlessly expanding human population in our country. This evidently attract our attention towards rainfed areas which accounts for 73.3 per cent (108 milli ha) of the total cultivated area in India and produces only about 42 per cent of the country's food production (Anonymous, 1984). In Himachal Pradesh only 16.1 per cent of the total cultivated area receives irrigation and rest depends upon natural precipitation (Anonymous, 1984). Although area under rainfed farming in the state (83.9%) is more as compared to irrigated but the average production from rainfed area is substantially low in comparison to irrigated areas. On an average against a potential of nearly 35 quintal/ha in the country, the dry farming farmer is harvesting only 4 to 8 quintal/ha of food grain (Kanwar, 1985). In Himachal Pradesh this situation is no better than the national average.

The problem of increasing productivity in dry land has important socio-economic implication and also with every passing year the gap between the farmer's grain yield in irrigated areas and dry farming areas is widening. Hence, there is an urgent need for the development of suitable dry farming

technology for the farmers of the state. In fact the whole philosophy of rainfed farming revolves around the principle that water is the limiting factor in these areas and one has to maximise the efficiency of natural precipitation whatsoever is available, because in dry farming areas the balance of moisture is always on deficit side which is bound to affect production ultimately resulting into total or partial failure of the crops.

The major problem of dryland areas are insufficient ground water and erratic rainfall, excessive runoff and sediment losses, low fertility of soils, more weed population and diseases and evaporation losses. To overcome these problems and to exploit the untapped potential for increased crop productivity in dry farming areas, measures have to be taken to increase the capability of land in retaining moisture and to efficiently harvest a single drop of water so received from rainfall. In Himachal Pradesh, this becomes particularly more important in rabi season because the major rainfall (about 80% of the total annual precipitation) is received during the monsoon period and the crops have to survive on carryover soil moisture and the little amount so received during winter season.

In Himachal Pradesh the area under rabi cereals is 387.4 thousand hectares and that under pulses and oilseeds is 55.5 and 20.2 thousand hectares, respectively (Anonymous, 1983) all of which play a dominant role in satisfying the food requirement of the people of the state. But the average yield per unit area is very low primarily due to water scarcity at certain critical stages of crop growth. Hence to achieve the target of maximum production per unit of water harvested is of paramount importance to conserve the natural precipitation in soil, minimise evaporation losses and utilize the available moisture more efficiently.

Various mulching materials have been reported to be effective in conserving soil moisture (Rajput and Singh, 1970). In fact mulching affects the physical, chemical and biological conditions of soil thereby resulting in overall good soil conservation. Favourable effects of mulching on crop yields (Roy et al., 1976) as well as on complex physico-chemical and biotic factors (Jack et al., 1955) have been reported. Synthetic mulches are in extensive use in developed countries (Adam, 1962) but worked out to be expensive. As an alternative it might be possible to use indigenous waste products as mulches. The unwanted weedy vegetation such as Lantana camara has spread in many parts of the country posing a serious problem to several plantation crops and has also spread to agricultural lands. This undesirable shrub is found in abundance in the non-arable lands of Kangra Valley of Himachal Pradesh.

Lantana camara L. belongs to verbenaceae family. It is a slightly prickly shrub 0.3 to 1.8m or more in height, native of tropical America and cultivated as an ornamental or hedge plant. Leaves opposite, ovate or ablong ovate, crenate, dentate, flowers usually yellow or orange changing to red or scarlet in dense axillary heads, fruits drupaceous, 0.5 cm dia greenish black.

The leaves and twigs of lantana are occasionally used as green manure in forest areas and for paddy crop in Mysore. Green material of Lantana has been found to contain 0.88 per cent N, 0.15 per cent P_2O_5 and 0.15 per cent K_2O on oven dry weight basis. Use of Lantana twigs in rice have also indicated good results for grain yield under Palampur conditions (Khan, 1984) and Bansal (1983) found no phytotoxic effect of Lantana fresh twigs on germination and plant growth of wheat.

Keeping in view the aforesaid points the present investigation entitled "Effect of Lantana mulch on water use efficiency, growth and yield of rainfed rabi crops" was carried out with the following objectives.

- i. To observe the effect of lantana mulch on the growth and yield of rabi crops.
- ii. To compare the water use efficiency values of various rabi crops with and without mulch.
- iii. To study the moisture depletion pattern by different rabi crops in the presence and absence of lantana mulch.
- iv. To determine the changes in soil properties under mulch and no mulch conditions.
- v. To calculate the economics of the crops.

REVIEW OF LITERATURE

Chapter 2

REVIEW OF LITERATURE

Mulches are mainly used for soil water conservation and soil erosion control but they influence other factors like temperature, weed competition, disease and pest infestation, in some cases availability of mineral nutrients and organic matter content of the soil and thereby influence crop yield.

Mulches have also been reported to increase the microbial activity near the soil surface because of increased energy supply and uniform moisture and temperature conditions.

In fact effectiveness of mulches depends on when and how they are used to modify the energy and water transport in the complex process of evaporation. Field experiments using mulches have shown beneficial effects of mulches in conserving and economising water use by crops ranging from 10-15 per cent depending upon the crop in which it is used, type and colour of mulches, type of soil, rainfall and amount of water added and temperature of both air and soil as stated by Ali and Prasad (1975). Synthetic mulches are in extensive use in developed countries (Adam, 1962) but worked out to be expensive. As an alternative it might be possible to use indigenous waste products as mulches. The unwanted weedy vegetation such as Lantana camara has spread in many parts of the country posing a serious problem to several plantation crop and has also spread to agricultural lands. This undesirable shrub is found in abundance in the non-arable lands of Kangra Valley of Himachal Pradesh containing 1.87 per cent nitrogen.

In the current chapter, an attempt has been made to review the pertinent literature on the growth and development of rabi crops. For the sake of convenience the review of literature has been presented under following sub-heads.

- 2.1. Effect of mulches on crop growth and development of rainfed rabi crops.
- 2.2. Effect of mulches on crop yield and water use efficiency of various rabi crops.
- 2.3. Effect of mulches on soil properties.
- 2.4. Effect of mulches on moisture depletion by rabi cereals, oilseeds and pulses.
- 2.5. Effect of mulches on economic feasibility of various rabi crops.

2.1. Effect of mulches on crop growth and development of rainfed rabi crops

An experiment was conducted at Palampur with pine needles as mulch material, Kapoor *et al.* (1978) reported that mulching with pine needles increased germination count, germination rate, plant height and number of total and effective tillers. An improvement in germination due to soil mulch was noticed in mustard (Joon *et al.*, 1984). An increase in plant height due to mulch application has also been reported by Roy *et al.* (1976), Rao and Agarwal (1984). Increased plant growth and vigour due to mulch application in comparison to control plots was recorded by Lal (1974) and Mohan *et al.* (1973).

Gupta and Gupta (1983) advocated that an increase in root growth, nodulation, shoot growth and plant water status were reported with increasing amounts of grass mulch. Straw mulch and cultivation enhanced root development in the upper 15 cm of soil and increased the lateral spread of roots for both years by maize (Chaudhary and Prihar, 1974). Bhan (1976) reported that mulching increased root development, moisture extraction and water use efficiency. Straw mulch @ 3.5 t/ha significantly increased tiller production, plant height, dry matter production and number of panicles per metre compared with no mulch or antitranspirants treatments (Agarwal and Rana *et al.* 1977). Sharma *et al.* (1981) found that mulches significantly increased fresh pod yield, straw yield, plant height and number of pods per plant.

Lantana twigs at higher dose increased the rice root length, shoot length or increased the growth of seedlings as well as the chlorophyll content of rice leaves (Bansal, 1983). Roy and Mukherjee (1982) sprayed crude aqueous extract of fruits of Lantana on the field grown wheat plants at different concentrations and found that more or less all characters of the treated plants showed better results over untreated control. Bansal (1983) found no phytotoxic effect of Lantana fresh twigs when mixed in soil on germination and plant growth of wheat.

On the other hand as reported by Reddy and Pandey (1980) mulches exhibited no perceptible effect either on plant height, number of branches, pods per plant or grain yield of mustard. Anderson and Russel (1974) also found decrease in plant height at heavier doses of mulches.

2.2. Effect of mulches on crop yields and water use efficiency

The effect of mulching on crop yield is an integrated effect of innumerable factors and it is difficult to attribute the yield increments to any single variable. In addition to the physical factors and availability of nutrients, the fertilizer response may be significantly affected by mulching due to complex physico-chemical and biotic factor (Jacks et al., 1955). Plant height, number of effective ears, length of ear, number of grains per ear and test weight were superior under mulched plots as compared to control ones (Roy et al., 1976). Straw mulch application was attributed to significant increase in the number of productive shoots and number of grains per spike, and it gave wheat grain yield to the tune of 2.47 t/ha as compared with 2.24 t/ha, without mulch. Number of pods per plant, number of grains per pod and 1000-grain weight was significantly higher in mulch than no mulch in sesame (Mandal and Ghosh, 1984).

Under dryland conditions; average grain yield of wheat increased by 100-330 kg/ha due to the application of straw mulch @ 1 - 10 t/ha (Kanivets and Fomin, 1977). Krishna and Pandey (1984) obtained 15 per cent increase in grain yield of lentil due to the application of straw mulch. Similar results were also obtained by Balyan and Malik (1981). Mulching with straw or black polythene mulch increased the seed yields of grain and lentil by 38.7 and 35.4 per cent, respectively (Ghosh et al., 1984). Beneficial effects of straw mulch were noted on the effective tillers, shoot dry weight, ear length and 1000-grain weight and consequently, respectively 46.5 per cent and 41.2 per cent gain in grain and straw yields were obtained (Puri and Gajendra, 1978). Use of mulch facilitated better mineralization and availability of nutrients which enhanced their uptake as well as utilization in improving or favourably modifying the various yield attributes to the better advantage of seed yield and the latter was boosted by 195 kg/ha over no mulch (Patel and Singh, 1980). Significantly higher yield of barley and grain were obtained with straw mulch @ 7 t/ha. The yield increments in barley and gram, respectively were 0.5 t/ha and 0.3 t/ha (Mandal and Vamadevan, 1975). The yield response of crops to combined application of mulch and Kaoline ranged from 29 to 48 per cent over control (Jain et al., 1983). The average increase in yield due to mulching was 26 per cent in early sown wheat and 31 per cent in late sown wheat (Kapur et al., 1978). Smika and Ellis (1971) found that number of tillers producing heads was significantly higher (10-15%) on mulch treated plots as compared to control ones of winter wheat. Application of bajra husk as surface mulch after germination led to an yield increase of 0.8 q/ha, which of course was non-significant (Singh et al., 1977).

The various mulches applied to soil after barley was sown in an attempt to reduce evaporation losses had little effect on yield or WUE (Saha et al., 1980).

Mulching with grass @ 9 t/ha resulted in maximum soil temperature, increase in root growth and increase of 200 per cent in average production of Vigna radiata (Gupta and Gupta, 1983). Prihar et al. (1972) after two years experiment concluded that application of rice husk @ 6 t/ha with 120 kg N/ha, increased the wheat yield by 5.2 q/ha as compared to the yield obtained by 120 kg N/ha alone. Mogueria et al. (1973) observed that grain yield of bean crop were 1.31 t/ha and 0.87 t/ha in a rice husk mulched and controlled plots, respectively. Kanoo et al. (1974) obtained increased yield of wheat and barley due to the application of mulches and increase was reported to be the result of prevention of lodging due to mulching.

Bansal et al. (1971) reported increase of 35 per cent in the yield of maize by the application of 2 cm thick Typha mats which resulted in increased temperature. Khan (1984) has reported 29 per cent increase in grain yield of rice by an incorporation of lantana fresh twigs @ 2 tonnes per hectare. Similarly, Sharma (1985) also recorded a significant increase in grain and straw yield of paddy by surface spreading of lantana litter and rice husk after 10 days of transplanting. The increase in grain yield due to lantana and rice husk were 21 and 28 per cent, respectively, whereas corresponding increase in straw yields were 10 and 9 per cent, respectively.

Anderson and Russel (1974), however, recorded that application of straw mulch @ 4000 and 5000 lbs/acre significantly depressed the mean yield of spring and wheat yield, as a result, higher rates delayed maturity upto 4-6 days shortened plant height and had negligible effect on plant population. Mulching

did increase the yield as well as productive capacity of water but the resultant increases were not significant to warrant extra expense of mulching (Balyan and Malik, 1981).

All mulches except FYM increase water use efficiency significantly and the highest value of 14.8 was obtained with straw mulch which was almost twice as compared with that of control (Ali and Prasad, 1975). The efficiency of water use with no mulch and mulch upto harvest was 76.3 and 112.2 kg per cm of water (Kapur et al., 1978).

2.3. Effect of mulches on soil properties

2.3.1. Effect on physical properties

a. Moisture conservation: Mulching affects both physical and chemical properties of soil. The organic matter content, an important factor in maintaining the fertility of soils. The mechanism of evaporation of water from soils has been the subject of controversy for a long time (Baver, 1940). This is especially true from the point of view of the practical significance of water losses by evaporation and method of controlling or minimising such losses. The amount of water that evaporates from soil after the surface has become relatively dry has remained a long debated subject. King (1907) measured the evaporation of water, over 100 days from three soils held in soil columns and placed in contact with a free water surface. Under these conditions water losses from a Virginia clay loam with a 4-inch dust mulch were only 37 per cent compared to same soil without mulch. Similar results were obtained with a sandy loam and a black marsh soils. King's evaporation experiments have demonstrated the importance of a dry loose layer of soil on the surface in order to break capillary connections with the immediate surface.

Lal (1974) reported the supremacy of straw mulch in moisture conservation over no mulch in corn crop. He clarified that the difference was more pronounced during frequent rains. Mulching also affects the soil moisture storage indirectly by controlling soil erosion. Because the unmulched plots erode severely, the loss of surface soil eventually decreases the soil moisture holding capacity.

Under dryland farming conditions, Hazra et al. (1973) reported that moisture conservation was greatly increased with the imposition of mulches on soil surface. The mulches reduced the evaporation from soil surface and thereby increased moisture status of soil at the sowing time of wheat in rabi season and that consequently increased seedling emergence.

Prihar et al. (1979) advocated that mulching of maize with green twigs of 'basooti' (Premna mucronata) few weeks before harvest, increased water storage, particularly in upper soil layers and wheat yield from 19.0 to 22.59 q/ha after maize.

In the field trials during seven years observed that net gains in the amount of water stored in the soil upto 2.8 inch were recorded as the result of increasing the quantities of wheat straw used as mulch during fallow. The net gains were significant in 12 of 16 experimental years (Greb et al., 1970).

Field experiments have shown beneficial effects of mulches in conserving and economising water use by crops ranging from 1.0 to 50 per cent, depending on the crop in which it is used, type and colour of mulches, type of soil, rainfall and amount of water added, wind velocity and temperature of air and soil as stated by Ali and Prasad (1975), Bansal et al. (1971), Choudhary and Chatterjee (1967), Mandal and Vamadevan (1975), Prihar et al. (1968) and Singh et al. (1967).

Mandal and Vanadevan (1975) reported that mulching with 7 ton husk and straw/ha was superior to no mulch in conserving soil moisture and increasing grain/seed yield of barley, mustard and toria. Straw mulch @ 2 t/ha was found beneficial in reducing soil and water losses, Pena (1980). Rajput and Singh (1970) reported that straw and polythene mulch conserved 24.7 and 32.2 per cent moisture, respectively over unmulched treatments. Han (1970) recommended that barley straw mulch to reduce runoff, soil erosion and increased soil moisture content. Sdobnikov and Moshchenko (1973) found that straw mulch @ 10 t/ha increased soil moisture content.

Alligation of straw mulch @ 10 t/ha increased soil moisture by reducing evaporation and resulted in increase in yield. Straw mulching affects the soil structure and porosity, both directly and indirectly. By minimising the direct impact of rain drops, there is a minimum crustation and therefore the initial pore space maintained. Indirectly mulching influences the activity of microflora and fauna and hence the soil structure. Lal (1975) observed that the mulched plots maintain their infiltration rate while a significant decline took place in the infiltrability of unmulched plots.

b. Soil temperature: Soil temperature is significantly influenced by tillage and crop residue management. Experiments at IITA (Lal, 1975) revealed that the differences in the maximum soil temperature of the mulch tillage/ plots were as high as 10 and 4°C for 20 cm depths in corn and soybean plots, respectively. The usual effect of mulch, whether of soil or plant residue, it is used to raise soil temperature during winter and to lower them during summer (McColla and Duffy, 1946). Murty and Rao (1969) recorded 4°C higher temperature in mulched plots as compared to unmulched ones during winter. Similarly, an increase in minimum and maximum temperature by polythene mulch was noticed by

Ghildyal and Tripathi (1979). This contention is also supported by Bansal et al. (1971), Brengle and Whitefield (1969), Albrecht (1976). Black (1972) found that soil temperature varied directly and soil moisture inversely with the rate of mulch applied and the proportion of area covered.

2.3.2. Effect of mulches on soil chemical properties

The most marked and most usually observed effect of mulching on the mineral nutrient content of soil is an increase in the available potassium content, suggesting a high water solubility of potassium compounds in many common mulch material. The effect of mulches in equalising the soil moisture regime is probably also reflected in reduced potassium fixation which occurs when soil dries out. Wander and Gourley (1938), Reuther (1941) and Baker (1943, 1948 and 1949) have reported beneficial effects of potassium supplied by mulches.

Strong residual effects of mulching on the nitrogen and phosphorus content were reported by Weeks et al. (1950). The increased mobility and availability are ascribed by Swenson et al. (1949) to the action of organic acids produced from the mulches that prevent combination of phosphate with iron or aluminium. Holmes et al. (1948) found considerably higher contents of phosphorus and potassium and slightly higher contents of calcium and magnesium in tomato on mulched than on the control plots.

Incorporation of organic substances, such as rice straw into submerged soil causes a dramatic change in chemical conditions of the soil (Ponnamperna, 1972) and makes some plant nutrient elements such as iron (in high pH soils) phosphorus and manganese, more available and others such as zinc, less available to rice plant. Hirose (1973) reported that depending on the C/N ratio of organic matter, when they are mixed or incorporated in soil, inorganic nitrogen available to plant is released from or immobilized in the soil organic matter.

If the C/N ratio is higher, more nitrogen is immobilised and very little is made available to the plant. The organic substances containing less than 1.5 nitrogen when incorporated under aerobic soils, generally immobilize soil nitrogen (William *et al.* 1968). However, Broadbent and Nakashima (1970) reported that there is very little difference in nitrogen immobilization per unit weight of decomposing organic substance between aerobic and anaerobic soil conditions.

Incorporation of straw upto 4 t/ha in well drained soil is harmless, while in poorly drained soils the chances of adverse effects are relatively high (Minami, 1976). Recovery percentage of straw nitrogen is about 10 per cent when 6 tons of straw/ha providing hardly about 4 kg N/ha (Yoneyama and Yoshida, 1977). Tanaka (1974) reported that due to the harmful effects of straw incorporation both traditional as well as high yielding varieties suffer at early growth stages. Since CO₂ is released during the course of straw incorporation, this may promote carbon assimilation of rice plant through CO₂ enrichment of the air around the plant which in turn may accelerate nitrogen fixation by blue green algae through increase in photosynthesis of algae (Tanaka, 1977).

Lal (1975) advocated that the crop which leaves more residue on the surface maintains the organic matter content and CEC at a higher level (e.g. maize) than those which leave little or no residue (soybeans). The role of suitable crop rotation is therefore important for maintaining organic matter and CEC of the soil.

A mulch after decomposition often increases the organic matter content of soil more than does ploughing in the same amount of plant residues

(Peele et al., 1948). Boller and Stephenson (1946) reported that there was higher organic matter content in mulched plots as compared to unmulched plots.

2.4. Effect of mulches on moisture depletion by rabi cereals, oilseeds and pulses

The magnitude of increase in yield that can be obtained by decreasing the soil water under a given soil fertility is said to be depend on the stage of occurrence of soil moisture stress and its duration, and also the capability of the plants to produce dry matter under these conditions. Plants differ in their capability to produce dry matter in events of abnormalities. Therefore the most important information generally needed about soil water is the amount it contained in the soil rooting depth both in irrigated and dryland farming practices. This moisture will vary with one or combination of factors like rainfall/irrigation, water supplies, evapotranspiration, runoff or deep aquifers, condensation and rising ground water table (Arora, 1971).

Muhammad et al. (1965) from green house and growth chamber studies, concluded that barley showed the lowest transpiration rate, oats the highest and wheat in between under all conditions. Water use efficiency was higher of barley followed by wheat and oats. The transpiration rate was the linear function of soil moisture content from the wilting to within 70 to 80 per cent of available soil moisture. At higher soil moisture contents the transpiration rate was more or less constant. Dembinska (1970) from his pot experiment studies reported that deficiency of moisture contents developed at ripening stage is most critical. Lehane (1962) observed that yields of grain were higher after early stress (40 days after sowing) than after late moisture stress (60 days after sowing), yields were less affected by stress on clay soils than on a sandy loam soil. In other words wheat is most dependent on

water supply during the filling stage (60-90 days after sowing) for producing high grain yield. Morgan (1971) observed that the death of spikelet in wheat, resulted from subjecting plants to drought at ear emergence.

Capacity of crops to extract moisture is another important factor for enduring effects of moisture stress. Bains and Chowdhary (1970) and many other have reported that crops differ markedly in their capacities to extract stored available soil moisture for their growth and development. If dryland farmers follow certain improved management practices, food grain crops in general, pulses and edible oils in particular can be grown profitably. Crops like arhar, gram, lentil, guar, bajra, sarson and linseed use up almost one quarter of the moisture available in the 100-200 cm profile whereas other can hardly use 5-8 per cent moisture. Bains and Singh (1971) investigated that among the principle dryland crops grown in rabi season on conserved soil moisture in Northwestern India, Sarson (Brassica campestris var. Brown sarson) exceeds in adaptability and yield potential. This crop extracted 80 per cent of the moisture from 50 to 125 cm soil depth at the age of 60-70 days as against dwarf wheat which extracted the same percentage from the soil depth of 50cm. On conserved soil moisture this variety can yield as high as 22 quintals/ha as against 5-6 quintals/ha from old varieties. Singh (1972) and Asthana et al. (1971) recommended the cultivation of linseed for dryland areas which is a short duration crop, matures in 114 days and completed its life cycle before severe moisture deficiency is noticed in the soil. Hedge (1964) reported that the cultivation of deep rooted companion crops not only increased the amount of soil moisture extracted by the roots and the consumptive water use but also the water use efficiency. The moisture extraction pattern

further showed that crop combinations like barley + gram, barley + sarson and barley + linseed caused a uniform soil moisture depletion from lower soil depths.

Krishnamoorthy (1971) revealed that in barani wheat cultivation, mixture of wheat and mustard, wheat and gram and wheat and linseed are taken as an insurance against loss if rains fail. Mustard, gram and linseed do relatively well under severe drought conditions during the rabi seasons as compared to wheat and barley. Barley can withstand drought better than wheat and hence in areas where winter rainfall is low, barley is grown in preference to wheat. Sharma (1969) observed that moisture extraction from the soil at depths of 60-120 cm was higher with pure stands of gram and with a 1:1 mixture than with pure stands of barley or with other mixture.

Gautam et al. (1961) showed that water use rate during the early stages of wheat growth i.e. within first 40 days (upto end of December) was only 0.78 and 0.88 mm per day during 1963-64, which increased steadily to a maximum of 3.25 mm per day at flowering stage (in February) and then decreased on the onset of senescence stage.

The rate of water intake from a given volume of soil depends on rooting density, the hydraulic conductivity of soil and difference between the average soil water suction and root suction (Gardner, 1964). In general, the rooting density is greatest in the upper layers than in the lower layers of the rooting zone. Allmaras et al. (1975) showed that root flow to root system progressed with time from shallow to deeper depths. Arya et al. (1971) working on similar lines reported that the proportional contribution of surface layers to the total water loss from 10-70 cm depth interval decreased as the plant matured, whereas the contribution of lower layers increased. Jaggi et al.

(1977) reported that deep soil layers (100-150 cm) contributed about 11-13 per cent of the seasonal water use by rainfed wheat. Saini and Ghildyal (1978) showed that the contribution of upward flux towards the total water requirement of wheat was 36 - 73 per cent, whereas, soil water depletion accounted for 11 to 19 per cent only. Acharya *et al.* (1979) reported that due to poor hydraulic conductivity of sodic soils, the flux divergence across the root boundary was negligible. In high exchangeable sodium (ES) soil, 78 per cent of the total root water extraction came from 0-15 cm layer whereas, in low ES soil 0-15 cm and 15-30 cm layers contributed about 77 per cent of the total water extraction by roots.

An increase in water extraction by crop roots has been observed with increasing soil water tensions (Yang and Jong, 1971; Sharma and Ghildyal 1977). Gregory *et al.* (1975) reported that the rate of water uptake per unit length of root for the whole soil profile and for individual soil layers generally decreased throughout the period of measurement.

Some workers (Stone *et al.*, 1973, Rice, 1975, Inyama and Black, 1977) have attempted to calculate the evapotranspiration rates from the root water uptake rates. Rice (1975) found that in Bermudagrass evapotranspiration rates calculated from water uptake rates were identical for two years. Inyama and Black (1977) observed that a good correlation existed between water uptake rate, root density and profile water depletion, and the results agreed well with the evapotranspiration calculated from the micro meteorological factors.

Gardner and Gardner (1969) reported that the mulch has its greater inhibiting effect upon evaporation, the first few days after rainfall. This is due to the fact that in the later stages of evaporation after wilting the

self mulching or soil mulch formation takes place. The porosity and thickness of self mulching or soil mulch is known to govern the evaporative losses to the atmosphere (Lanks, 1958; Holmes *et al.*, 1960; Acharya and Prihar, 1969).

Apart from moderation of hydrothermal regime, the practice of mulching with crop residues has several other indirect effects. Several workers have reported an increase in root weight density with mulching and its positive effect on crop yield (Allmaras and Helson, 1971; Chaudhary and Parihar, 1974; Acharya and Phogat, 1984).

The greater amount of roots near the soil surface, as a result of mulching with crop residues, has been associated with better utilization of applied nutrients at the surface (Shear and Moschler, 1969; Triplett and Van Doven, 1969; Sharma *et al.*, 1982).

2.5. Economic feasibility of various Rabi crops

The strategy of agricultural planning followed in India resolves around a certain figure known as target of production to be achieved within a fixed time which involves only production planning (Jain, 1967). Patil and Kulkarni (1973) suggested that crop planning is very important before undertaking any multiple-cropping system and also for optimum utilization of input resources. Heady (1957) reported that the physical considerations determine the enterprise relationship among the various crops and how each fits into the overall management plan. The economic consideration weight the relative advantage of each crop and to serve in the selections of a rotation to increase the profit of the farm. Though the effects of soil type, fertility level, and climate on the yield of different crops are known, deciding on the most profitable system of land use requires the use of economic principles.

Chandani et al.(1960) reported that capital requirements were high for potato, sugarcane and maize crops. The remunerative crops were wheat, sugarcane, berseem, maize and cowpeas and purely cereals rotation having one or more of each crops.

Crop sequence including maize and wheat with leguminous crops as green fodder was reported to be the most paying proposition by Gautam and Singh (1970).

Bains et al.(1971) studying the profit potentials in respect of different Kharif and Rabi crops under dryland observed that sarson (Var. 15421) gave the top net profit of Rs.2406.25/ha, castor and arhar Rs.2255.50 and Rs.2245.20/ha, respectively whereas taramira (Rapeseed), barley and wheat crops Rs.1559.00, 282.00 and Rs.27.10 per hectare, respectively. They concluded that each rupee invested in the cultivation of sarson brings in about Rs.3.00 in return as against Rs.3.00, Rs.2.75, Rs.1.00 and Rs.0.50 from gram, linseed, barley and wheat, respectively. Rajbans et al.(1967) under dryland experimentation of 5 years obtained fairly good response from wheat + gram mixture than their pure stands in general and under dry regions in particular. Mixture of cereals and legumes are the insurance against total failure of crops under adverse weathering or severe droughts under legumes leaves soil richer in nitrogen as compared to cereal alone after crop harvest.

Ramamoorthy et al.(1973) studying the profitability of fertilizer use for dryland wheat stated that under typically dryland conditions, where there is usually a considerable variation in available soil moisture and other soil physical properties the prediction of crop response of wheat (Kalyansona) on the basis of fertilizer was 29 per cent.

Mehrotra et al. (1970) stated from their mixed cropping results of barley and gram that the average performance from mixed cropping barley benefitted in growth, yield and nitrogen content, while gram depressed in growth and nitrogen content. The combined yield was slightly less than pure barley, but the differences and the monetary returns were not significant. Soil nitrogen was enriched by the association with legumes. Lenkov (1969) studying reciprocal relationship between barley and wheat in mixed sowing of 1:1 mixture found that barley was strongly competitive with wheat, reducing the growth and yield of wheat markedly. This was mainly due to the more vigorous tillering, faster development and greater stem height of the barley.

Lal and Ray (1976) reported that annual net return of Rs.10,414.00 per hectare was highest with 400 per cent cropping intensity (green gram-maize-potato-wheat). Net return declined progressively with a decrease in the cropping intensity from 400 to 100 per cent. The profit cost ratio was found to be maximum under 300 per cent cropping intensity (green gram-maize-wheat) and was Rs.2.57 per rupee invested. Rotation that includes potatoes with maize and wheat crops, proved best in every respect (Sandhu et al., 1973). This was attributed to the high yield produced by potatoes. A rotation of wheat-maize-redish proved to be most profitable at Palampur (Sharma, 1973).

MATERIAL AND METHODS

Chapter 3

MATERIALS AND METHODS

The experiment was conducted in Watershed Management Area of the Agricultural Research Farm of Himachal Pradesh Krishi Vishva Vidyalaya, Palampur during Rabi 1985-86. The details of materials used and methods employed during the course of these investigations are described as under:

3.1. Site

The experimental farm is situated at a latitude of $32^{\circ}6'$ N and longitude of $76^{\circ}3'$ E at an altitude of 1290.8 metre above mean sea level.

3.2. Weather and Climate

Weather parameters like maximum and minimum temperature, evaporation, relative humidity, rainfall etc., for the crop season were recorded at the Meteorological Observatory, located near the experimental site of the farm of H.P. Krishi Vishva Vidyalaya, Palampur and have been presented in Fig.1 and appended in Appendix I.

The climate is sub-temperate with very high rainfall. The average annual rainfall of the experimental site is 2521.2 mm (Average of 7 years) a major portion of which is received during June to September (74% of the total). The total rainfall received during crop season amounted to 408.4 mm. The mean maximum and minimum temperature recorded were 28.8°C and 3.4°C during April and January, respectively. The mean weekly relative humidity during the crop season ranged from 29 to 59 per cent.

3.3. Soil Temperature

Soil temperature was recorded with the help of soil thermometers daily in the morning at 6.30 AM and 2.30 PM from the three depth at 0-20cm, 20-40cm and 40-60cm from mulched and non-mulched treatments. It has been presented graphically in Fig.2A and 2B and appended in Appendix II.

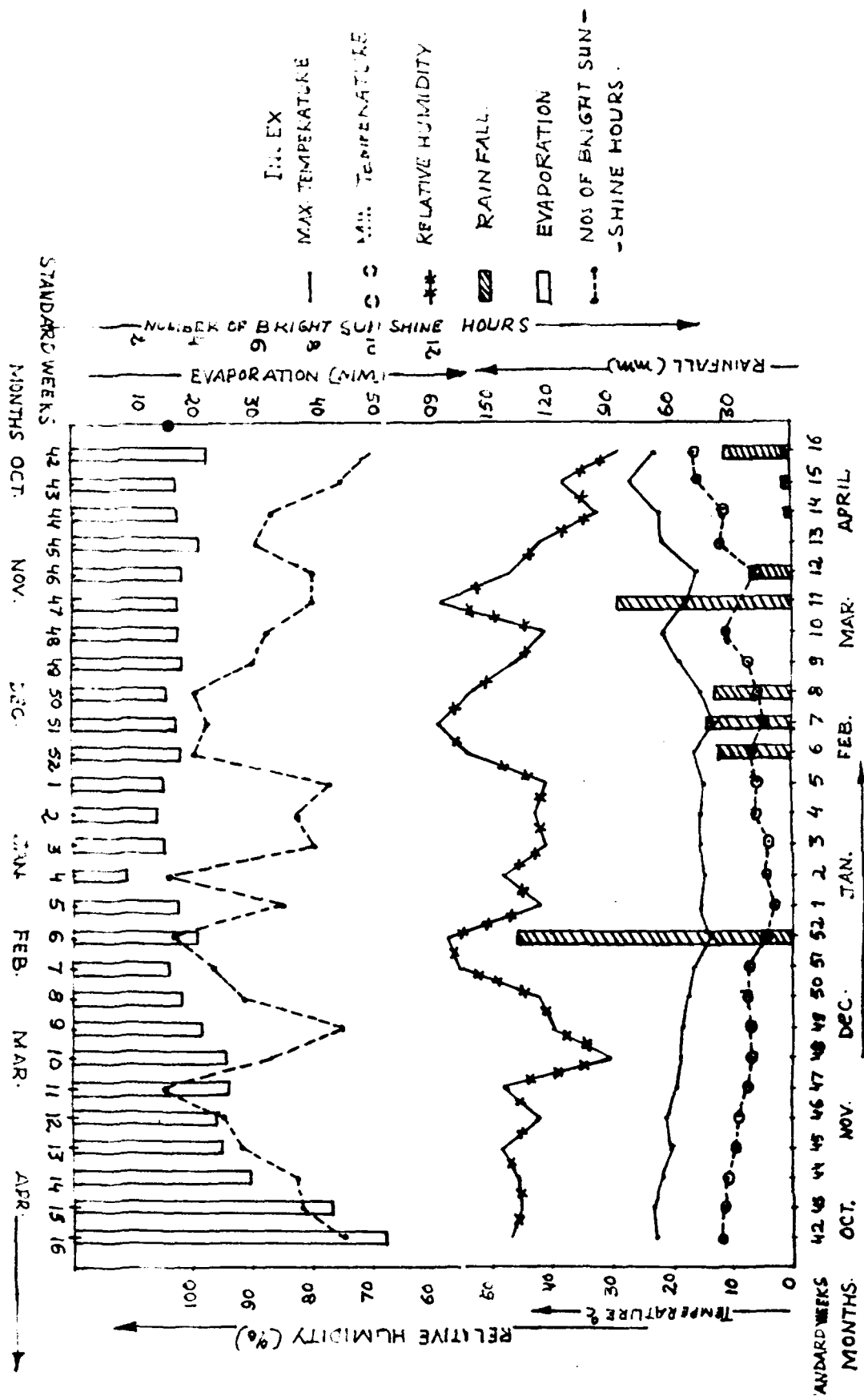

FIG.1 MEAN WEEKLY WEATHER DATA RABI 1985-86

In upper soil layers maximum temperature was recorded during 4th week of April both under mulched (29.8°C) and no mulch (30.1°C) whereas minimum temperature was recorded during 1st week of January 1986 which was 5.9°C for mulched and 3.8°C for unmulched plots.

In 20-40 cm soil depth the maximum soil temperature was recorded during third week of April in both the treatments. Under mulched conditions the maximum temperature was recorded 25.4°C whereas under no mulch condition it was 26.9°C . The minimum temperature was found during 1st week of January, 1986 both under mulch and no mulch was 6.1°C and 4.9°C , respectively.

In lower depth of soil (40-60 cm) the maximum temperature was recorded in both conditions. It was found maximum during last week of April 1986 under both mulch (22.5°C) and no mulch (23.1°C) and minimum temperature was recorded during 1st week of January under both treatments i.e. mulch 4.2°C and no mulch 7.5°C .

3.4. Soil analysis

Representative composite soil samples from the surface soil (0-20 cm) of the field were collected before sowing and were processed for analysis. The results of mechanical analysis are given in the Table 1. For the determination of available N, P and K in the soil before sowing and after harvesting, the soil samples were taken from 5 places of each plot at a depth of 0-20 cm and mixed together to have one composite sample per plot.

3.5. Cropping history

The experimental field was under commercial cultivation of maize + soybean with preceding season Kharif 1985 and wheat + mustard during Rabi 1984-85. Wheat and maize were sown in the fields with recommended doses of

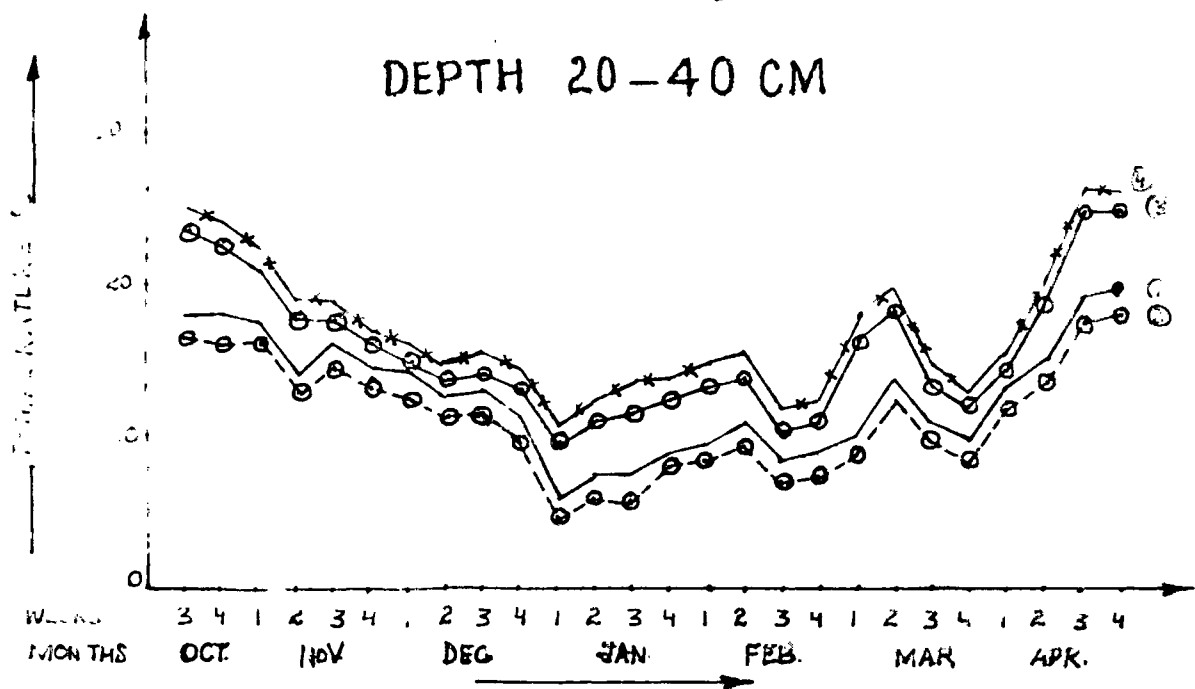
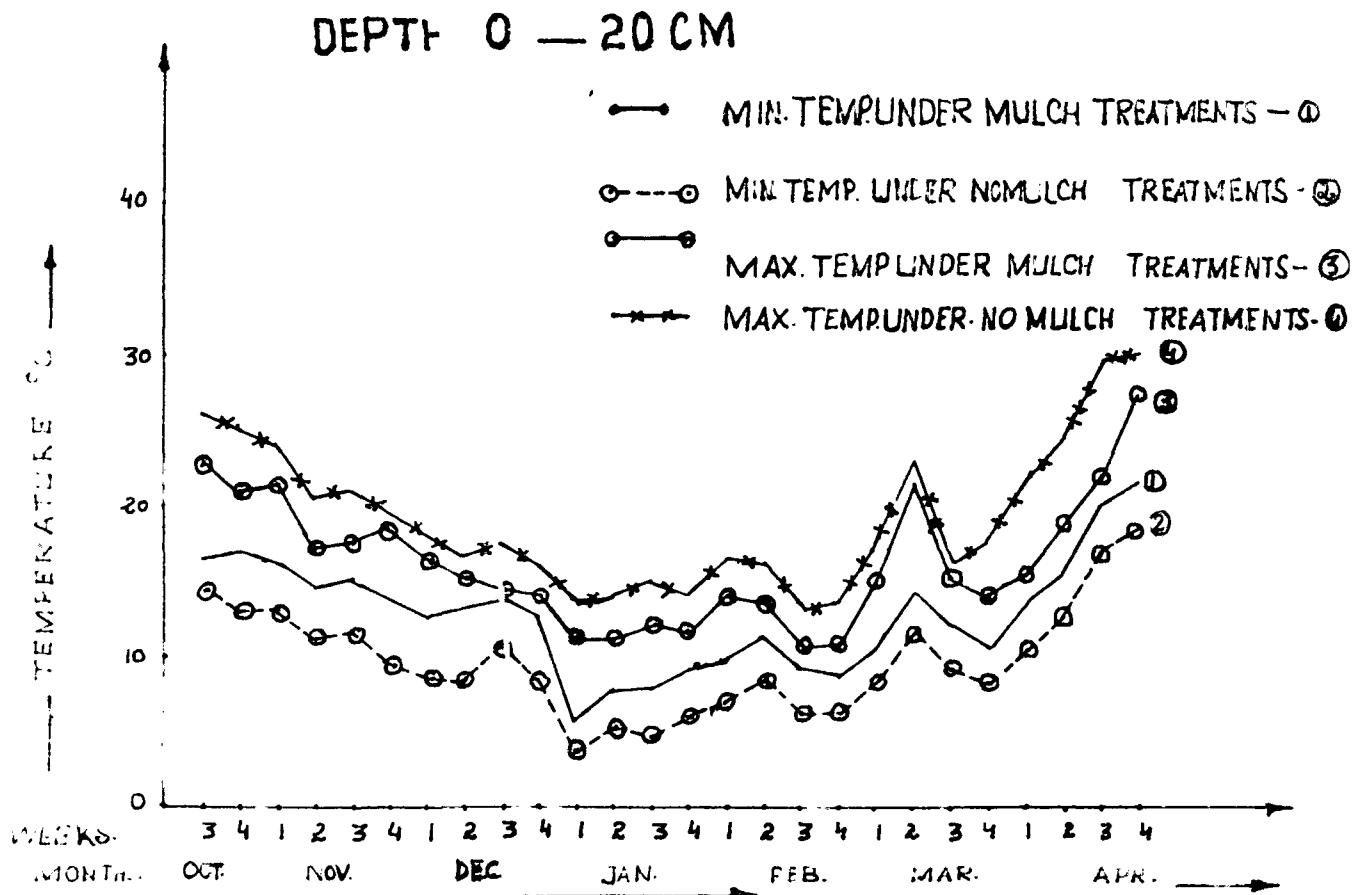

FIG. 2-A WEEKLY MEAN SOIL TEMPERATURES (°C)

DEPTH 40-60 CM

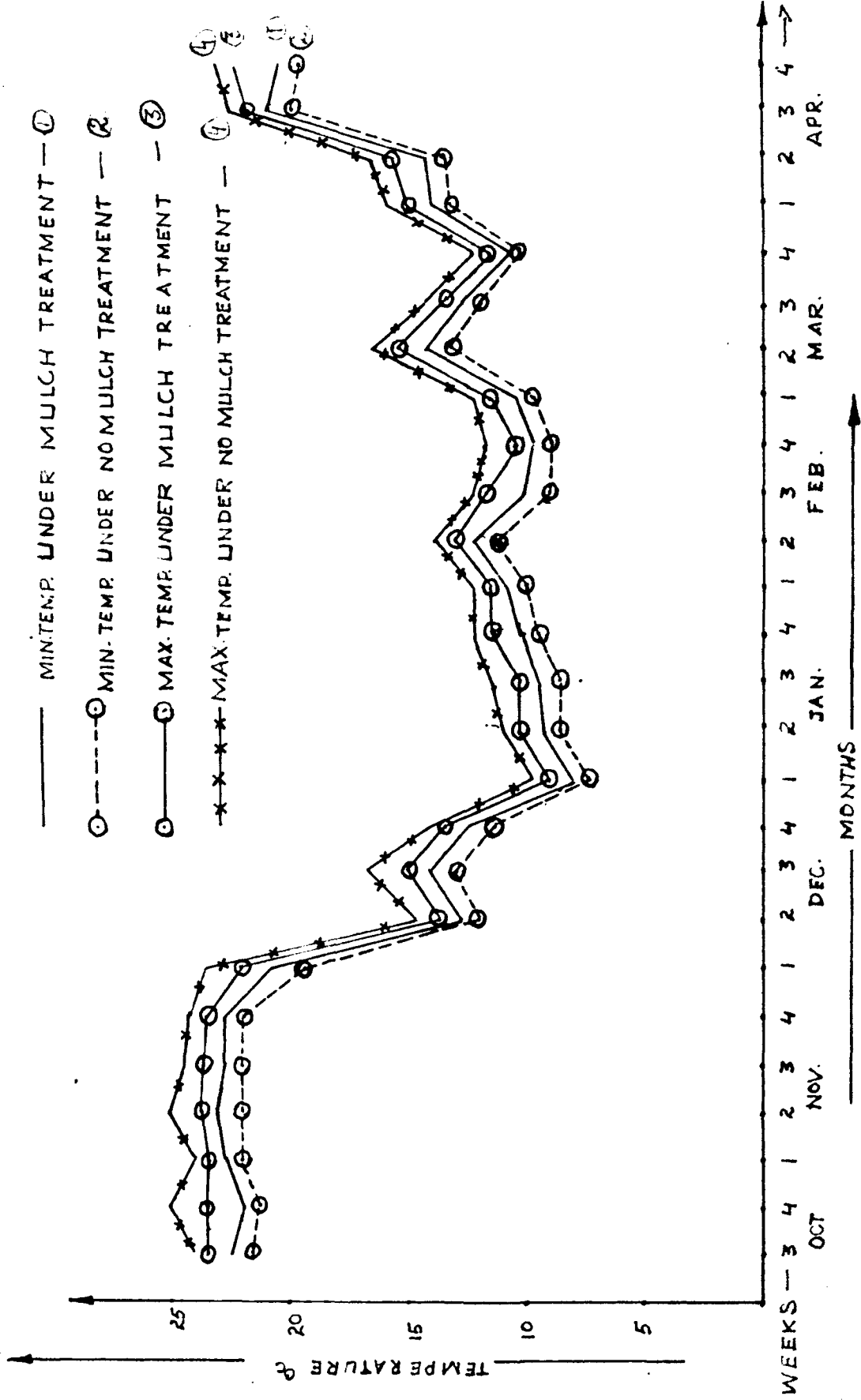

FIG. 2. WEEKLY MEAN SOIL TEMPERATURE (°C)

Table 1. Mechanical and chemical analysis of soil

Particular	Content	Method used
A. Mechanical analysis		
Sand (%)	28.00	International pipette method
Silt (%)	39.76	(Piper, 1966).
Clay (%)	27.55	
<u>Bulk density (g/cc)</u>		
0-20 cm depth	1.18	Core sampler method
20-40 cm depth	1.31	(Sodman, 1942).
40-60 cm depth	1.32	
<u>Available soil moisture at sowing time (cm)</u>		
0 -20 cm depth	5.61	Gravimetric method
20-40 cm depth	6.72	
40-60 cm depth	7.07	
<u>Field capacity (%)</u>		
0 -20 cm depth	23.60	Field method (Coleman, 1944)
20-40 cm depth	28.06	
40-60 cm depth	26.14	
<u>Wilting point (%)</u>		
0 -20 cm depth	13.64	15 atmospheric tension values
20-40 cm depth	13.41	by pressure membrane apparatus
40-60 cm depth	12.68	(Richard, 1943).
B. Chemical analysis		
pH	5.57	1:2.5 soil water suspension Glass electrode pH meter (Jackson, 1967).
Organic carbon (%)	0.85	Walkley and Black Rapid Titration method (Piper, 1966).
Available nitrogen (kg/ha)	487.70	Alkaline permanganate method Subbiah and Asija (1956).
Available phosphorus(kg/ha)	18.70	Olsen's method of extraction with 0.5M NaHCO ₃ pH 8.5 and development of blue colour by chlorostannous reduced molybdophosphoric acid (Olsen et al. 1954)
Available potassium (kg/ha)	246.50	Extraction with normal neutral Ammonium acetate and Flame photometric determination in extract (Merrin and Peech, 1950).

fertilizer during Rabi 1983-84 and Kharif 1983, respectively under rainfed conditions. The cropping history of the experimental farm is present in Table 2.

Table 2. Cropping history of experimental farm

Year	Crop	Kharif			Crop	Rabi		
		N (kg/ha)	P ₂ O ₅ (kg/ha)	K ₂ O (kg/ha)		N (kg/ha)	P ₂ O ₅ (kg/ha)	K ₂ O (kg/ha)
1983-84	Maize+soybean	120	60	40	Wheat + mustard	120	90	30
1984-85	Maize	120	60	40	Wheat	90	45	45

3.6. Experimental details

The experiment was laid out in Rabi 1985-86 and the treatment combination of factors are given below:

A. Treatments

<u>Crop</u>	<u>Variety</u>
1. Wheat	VL- 421
2. Barley	HBL- 87
3. Linseed	Himalini
4. Mustard	BSE-1
5. Lentil	HPL - 5

B. Level of mulching

1. Mulched (Lantana camara fresh litter @ 10 t/ha)
2. No mulch (Control)

Design : Randomized Block Design

No. of treatment combinations : 10

No. of replications: 4

Total number of plots: 40
 Gross plot size : 5m x 2.5m = 12.5 m²
 Net plot size : 4m x 2m = 8 m²
 Inter row spacing : 25 cm (Common for all crops but intra-row spacing as per recommendations for individual crops).

3.7. Field preparation

The experimental plot was ploughed, harrowed, levelled and the clods were broken to have a fine tilth and a good seed bed preparation.

3.8. Layout

The experiment was laid out with manual labour. The plan of layout is given in Fig.3.

3.9. Fertilizer application

Fertilizers were applied to all the crops according to the recommended package of practices for individual Rabi crops. Treatment-wise 1/2 dose of N and full dose of potash and phosphorus was applied by pora method at the time of sowing for wheat, barley, linseed and mustard and the remaining half dose of nitrogen was topdressed at the first rainfall or after 3-4 weeks. In case of lentil the full dose of nitrogen as starter dose with full phosphorus and potassic fertilizers were applied at the time of sowing. Required quantity of fertilizers were calculated and weighed. Fertilizers were applied in furrow opened by hand plough and thoroughly mixed with soil by means of wooden stick before sowing the seed.

3.10. Sowing

Treatment-wise seeds of wheat, barley, linseed and lentil were sown in 4 to 5 cm deep furrows by Kera method in rows spaced at 25cm apart.

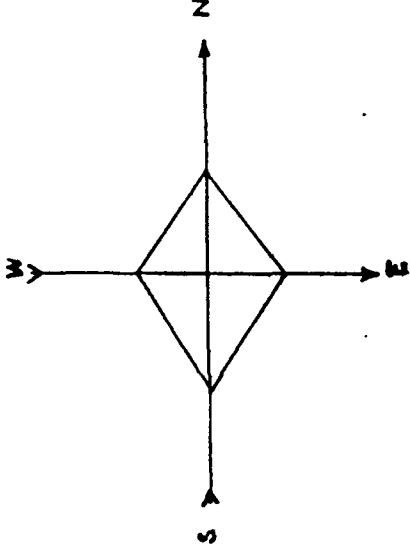

INDEX.

- C1 : WHEAT
- C2 : BARLEY
- C3 : LINSEED
- C4 : MUSTARD
- C5 : LENTIL
- M : MULCH
- NM : NOMULCH

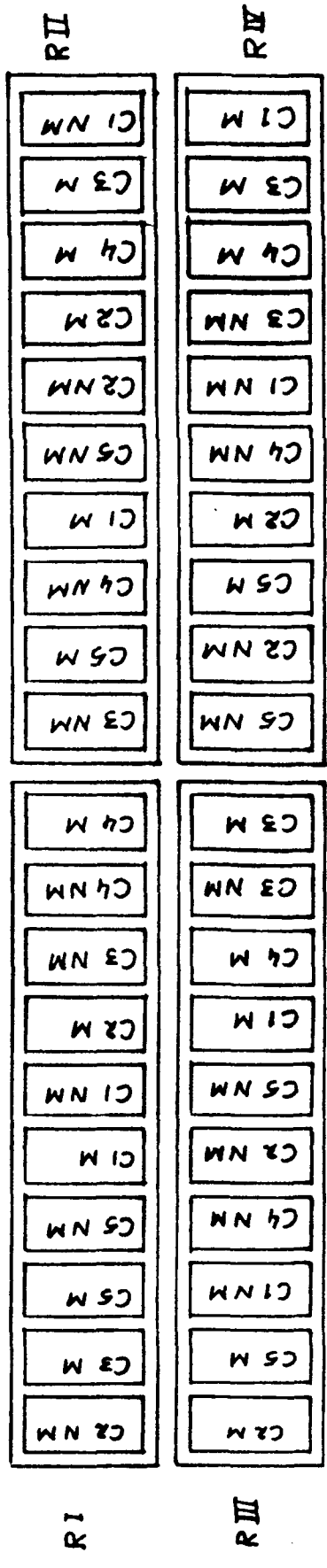

FIG.3 PLAN OF LAY OUT

DESIGN : R.B.D
 REPLICATION : 4
 TREATMENTS : 10

GROSS PLOT SIZE : 5m x 2.5m = 12.5 m²
 NET PLOT SIZE : 4m x 2m = 8.0 m²
 TOTAL NO. OF PLOTS : 40

Whereas, mustard was sown in 2-3 cm deep by Kera method and the row to row distance was 25cm. After sowing the furrows were covered with soil. The seeds of wheat and barley were sown at the rate of 120 kg/ha, whereas 30 kg/ha seed rate was applied in lentil and linseed and 6 kg/ha seed was used in case of mustard.

3.11. Application of mulch

After sowing the seed fresh Lantana camara litter (chopped) @ 10 t/ha was uniformly spread over the plots for mulch treatments.

3.12. Harvesting and threshing

The crop was harvested manually when the grains hardened and the straw/stover become dry and brittle. Before harvesting the crop, four rows from each plot i.e. two from either side and 50 cm row length from both ends of each row of each plot were separated to eliminate border effect. The remaining plants were cut close to the ground. The harvested plants from each plot were made into bundles separately, tagged with proper labels and carried to the threshing floor. The weight of individual bundle from each plot was recorded after sun drying. Threshing was done for each plot separately beating by stick with the help of manual labour. The net plot harvested was 4m x 2m i.e. 8.0 sq.m.

3.13. Cultural operations

The schedule of cultural operations carried out from sowing to harvesting of crops is being listed as under in Table 3.

Table 3. Calendar of cultural operations.

S.No. Operation	Date	Particulars of operations
1. Field preparation	14.10.85	One ploughing, one harrowing and planking.
2. Layout	16.10.85	The layout was done as per plan shown in Fig. 3.
3. Fertilizer application	18.10.85	Fertilizers were thoroughly mixed and applied in furrows as mentioned in section 3.9.
4. Sowing of seeds	18.10.85	Seeds were sown as described in section 3.10.
5. Mulching	18.10.85	By manual labour
6. Interculture	28.11.85	By manual labour
7. Top dressing	28.12.85	By manual labour
8. Harvesting		
i. Mustard	28.3.86	By manual labour
ii. Barley	18.4.86	By manual labour
iii. Wheat, linseed and lentil	29.4.86	By manual labour
9. Threshing and Winnowing		
i. Mustard	3.4.86	By manual labour
ii. Barley and lentil	4.5.86	By manual labour
iii. Wheat and linseed	5.5.86	By manual labour

3.14. Biometric observations

3.14.1. Emergence count

Total number of shoots after complete emergence from 3 observational units from one metre row length were counted and the mean number of shoots were calculated.

3.14.2. Tillers/Branches

Ten plants were selected randomly in different rows from the net plot and total number of tiller/main branches of these plants were counted and then averaged out to have number of tillers or branches per plant.

3.14.3. Effective and noneffective tillers/branches

From the tillers counted above, the effective and noneffective tillers/main branches were counted at the time of maturity. The tillers/main branches bearing grains were taken as effective and others were counted as non-effective tillers/main branches.

3.14.4. Plant height

Ten plants were selected at random from the net plots of different rows of each plot and plant height was measured at 30 days interval from collar to top of the ear less the awn. Average was taken from these ten plant samples.

3.14.5. Days to flowering

In the three observational unit from the day flowering started, the number of plants were recorded at every alternate day. The date on which 80 per cent plants had completed flowering as noticed by visual observation was recorded and number of days from sowing to that date were taken as days to flowering.

3.14.6. Days to maturity

In the three observational units average number of days taken to maturity were recorded from individual plot. Plants observed in alternate days and the date on which 80 per cent plants turned yellow coloured was taken as maturity day and then the number of days from sowing to maturity were worked out.

3.15. Yield Attributes

3.15.1. Number of grains per ear/per pod

Five plants were taken at random from each plot and they were threshed separately and number of grains counted. The average number of grains per ear or per pod and per seliqua was worked out.

3.15.2. 1000-grain weight

From the produce of each plot, grain samples were taken, 1000-grain were counted and weighed. The mean weight in gram was worked out and reported.

3.15.3. Grain yield

After harvest, the plants were tied in bundles for each net plot sun dried for five-six days and sun dry weight was recorded (kg/plot). After threshing and cleaning the weight of clean grains were recorded. The yield kg/plot were converted into kg/ha or q/ha before reporting.

3.15.4. Straw yield

The straw yield was worked out by subtracting the grain yield of each plot from the total produce of the net plot. The yield kg/plot converted into q/ha.

3.15.5. Grain : straw ratio

The grain yield of the net area harvested was divided by corresponding straw yield and expressed in kg/ha.

3.15.6. Wheat Equivalent yield

The economic yields of various crops in different treatments were converted into wheat equivalent yield to facilitate comparison of different crops and different types of economic produce. Wheat equivalent yield was calculated by multiplying the crop yield (kg/ha) by a wheat equivalent factor

which was calculated from the ratio of price of unit weight of concerned crop and the price of unit weight of wheat. The yield of all the crops involved in the system were thus converted into wheat equivalent yields as suggested by Lal and Ray (1976).

Wheat equivalent yield was thus calculated by using following equation:

$$\text{Wheat equivalent yield (WEY)} = \sum_{i=1}^n (Y_i e_i) \dots \dots \dots (3.1)$$

Where $i = 1$ to n number of crops

Y_i = Economic yield of crops in kg/ha

e_i = Wheat equivalent factor and can be given by PC/PM

PC = Price of unit weight of concerned crop

PM = Price of unit weight of wheat.

The produce of various crops was sold at the rates mentioned below:

Crop	Rate q/ha (Rs.)		Source
	Grain	Straw	
Wheat	165/-	40/-	Directorate of Research
Barley	155/-	40/-	H.P.Krishi Vishva Vidyalaya
Linseed	400/-	30/-	Palampur
Mustard	480/-	30/-	
Lentil	365/-	30/-	

3.16. Soil Moisture Studies

3.16.1. Soil Moisture content

Soil samples with the help of an soil probe (manually operated tube auger) from three depth (0-20, 20-40cm and 40-60cm) were taken from each plot and moisture content was determined by drying the samples in an electric

oven at 105°C for 12 hours or till constant weight and moisture percentage was calculated on oven dry weight basis. The average content of soil moisture for each treatment was determined at 15 days interval by using the formulae:

$$\text{Per cent moisture} = \frac{\text{Fresh weight} - \text{dry weight}}{\text{Dry weight}} \times 100$$

3.16.2. Soil moisture status

Periodical soil moisture status of the profile was calculated by the following procedure (Binkowski, 1961).

$$\frac{WS - DS}{DS} \times T \times Bd = Wt \text{ and } (Wt - PWP) = Wa$$

Where, WS = Fresh weight of soil samples

DS = Dry weight of soil samples

T = Thickness of sample

Bd = Bulk density of soil at sampling depth

Wt = Total water content

PWP= Moisture content at 15 atmospheric tension

Wa = Available water content.

The soil moisture content in each layer was added to know the total moisture content in root zone at various crop growth stages.

3.16.3. Total Water expense

Water expense under different soil moisture treatments was calculated by adding up the amount of soil profile moisture and rainfall during the crop growing season. The rainfall is one event and if it was more than 5 cm (a depth of water just enough to wet effective rooting depth of 60 cm) was discarded as either deep percolation or surface runoff losses. Besides, if the rain cycle was repeated within 48 hours may be of any amount was also not

accounted as profile water, use and taken as an excess than available range of water, if the rain event occurred within 48 to 72 hours then only 50 per cent of it is taken as effective rainfall and beyond 72 hours upto 96 hours taken 75 per cent and afterwards as 100 per cent effective rainfall was taken as soil profile water within available range.

3.16.4. Consumptive use of water

The soil moisture was determined by gravimetric method. The consumptive use for various sampling intervals was calculated as follows:

$$CU = \sum_{i=1}^n \frac{M_{1i} - M_{2i}}{100} \times Db_i \times D_i + I + R$$

Where, CU = the consumptive use from the root zone in cm of water,

n = the number of layers in root zone from which moisture was determined,

M_{1i} = the moisture per cent by wt. at the first sampling date of interval in the ith layer.

M_{2i} = the moisture per cent by wt. at the second sampling date of interval in the ith layer.

Db_i = the bulk density of the ith layer.

D_i = the depth of the ith layer in cm.

I = Irrigation applied during the interval in cm

R = rainfall during the interval in cm.

3.16.5. Daily water use

Daily water use worked out by dividing the total amount of water used by a particular crop by the number of days taken by that crop upto harvesting.

3.16.6. Cumulative water use

Cumulative water use was calculated by summing up the water use by a particular crop during successive growth stages.

3.16.7. Net returns/mm of water used

It was worked out by dividing the net monetary returns of each crop by the total amount of water consumptively used during the whole life of the crops.

3.16.8. Water use efficiency

Water use efficiency was calculated for both grain and straw yields separately and also against the total yield by the following formula.

$$WUE = \frac{Y}{CU}$$

where, WUE = Water use efficiency (kg/ha/cm)

Y = Dry weight of grain/straw (kg/ha)

CU = Total water expense (cm/ha)

3.17. Economic Studies

To work out the most profitable treatment, the economics for each treatment on the basis of current price of the inputs and produce, obtained from the office of Seed Production Officer, H.P. Krishi Vishva Vidyalaya, fixed by the Director of Research, H.P. Krishi Vishva Vidyalaya for Rabi 1985-86. The details are given in Appendix XX.

3.17.1. Cost of cultivation of different crops

The cost of cultivation of different crops was worked out separately and appended in Appendix XV, XVI, XVII, XVIII and XIX. The requirement of labour and mechanical power for different operation, such as ploughing, harrowing, weeding irrigation and harvesting, were calculated for

hectare as per the rates prevalent at experimental farm. Cost of inputs, such as fertilizer and seed were calculated based on the actual doses/ amounts applied.

3.17.2. Gross Returns

The yields of different crops were converted into gross return in rupees based on the prevailing local market prices of different commodities and bye-products such as stover or straw of wheat, barley, linseed, mustard and lentil. The ultimate values were worked out.

3.17.3. Net return

This was calculated on the basis of following method:

Net return = Gross return - Cost of cultivation

Net return per rupee invested = $\frac{\text{Net returns (Rs.)}}{\text{Cost of cultivation (Rs.)}}$

3.18. Statistical analysis

All the data collected pertaining to these investigations were subjected to the statistical analysis. The standard statistical method given by Panse and Sukhatme (1978), Nigam and Gupta (1979) and Fisher and Yates (1963) were followed. The significance of 'F' and 't' was tested at 5 per cent level of probability and critical difference values were calculated when 'F' and 't' tests were found significant.

EXPERIMENTAL RESULTS

Chapter 4

EXPERIMENTAL RESULTS

Results of present investigation entitled " Effect of Lantana Mulch On Water Use Efficiency, Growth and Yield of Rainfed Rabi Crops" conducted during Rabi 1986 are presented in this chapter alongwith appropriate tables and diagrams. Since the growth, development and yield attributes of different crops vary too much in their parameters under study, the Student's 't' test was applied to study the mean differences of different parameters of different crops for mulch and no mulch treatments. However, the corresponding analysis of variance tables were also given in the Appendix section.

4.1. Growth attributes

4.1.1. Germination count

The data on germination count and number of tillers of various crops as affected by different treatments have been presented in Table 4.1 and corresponding table for student's 't' test has been given in Appendix III.

Table 4.1. Mean treatment effects on growth attributes of crops

Crop	Germination count	Number of tillers or
	per metre row lenth	branches per plant
	<u>Mulch</u>	
Wheat	22.00	4.50
Barley	20.00	4.25
Linseed	24.50	3.75
Mustard	19.00	6.25
Lentil	23.25	5.00
	<u>No mulch</u>	
Wheat	20.00	3.00
Barley	18.50	2.75
Linseed	23.25	2.50
Mustard	17.25	4.25
Lentil	22.00	3.50

Significant at 5 per cent level of probability.

Mulching with Lantana mulch was found to have no effect on the germination of rabi crops (Table 4.1). Similarly, number of tillers or branches per plant recorded at harvest did not differ significantly from mulch applied and control plots as is apparent from data in Table 4.1 but overall performance under mulched treatments was better for these two characters.

4.1.2. Plant height

The data on plant height recorded at various growth stages of different crops have been presented in Table 4.2 and corresponding student's 't' test in Appendix IV.

Table 4.2. Mean treatment effects on plant height (cm)

Crop	Days after sowing					At harvest
	30	60	90	120	150	
	<u>Mulch</u>					
Wheat	12.30	19.47	25.83	66.06	84.93	104.69
Barley	12.40	17.75	20.01	41.78	69.02	10.62
Linseed	5.66	15.19	22.68	45.33	60.31	77.27
Mustard	7.01	18.10	50.60	82.34	86.42	
Lentil	4.47	6.62	9.07	18.17	29.51	41.06
	<u>No mulch</u>					
Wheat	8.85*	12.72*	15.42*	41.29*	59.65*	71.34*
Barley	8.65*	9.62*	10.75*	17.37*	52.91*	41.80*
Linseed	5.90	15.06	20.06	41.47	45.09*	77.40*
Mustard	5.38	20.26	40.53*	63.05*	68.14*	
Lentil	4.51	6.33	7.90	15.83*	23.97*	37.64*

* Significant at 5 per cent level of probability.

As is evident from the Table 4.2, in wheat and barley mulch treated plots produced significantly taller plants than unmulched ones at 30, 60, 90, 120 and 150 DAS (Days after sowing) as well as at harvest. However, the trend was somewhat different in other crops. In linseed plant height from mulched and unmulched plots remained statistically at par except at harvest where plots supplied with lantana litter produced markedly higher plants than those with no mulch. In mustard, mulched plots produced significantly taller plants at 90 DAS, 120 DAS and at harvest, whereas in lentil significant differences were observed only at 150 DAS growth stage and at harvest only.

4.2. Development stages

Data pertaining to development stages as influenced by various treatment combinations have been presented in Table 4.3 and corresponding 't' test in Appendix V.

Table 4.3. Mean treatment effects on development stages

Crop	Days to flowering	Days to maturity
	<u>Mulch</u>	
Wheat	130.25	177.25
Barley	116.25	153.50
Linseed	123.75	166.00
Mustard	80.25	140.00
Lentil	123.50	160.25
	<u>No mulch</u>	
Wheat	120.50**	160.50*
Barley	107.50**	143.75**
Linseed	114.25**	159.00*
Mustard	73.00**	137.00*
Lentil	115.75**	155.75*

* Significant at 5 per cent level of probability.

**Significant at 1 per cent level of probability.

As is apparent from the table, the plants in mulched plots flowered significantly later than the plants receiving no organic waste material. Likewise plants in mulched plots attained maturity later than their counterparts.

4.3. Yield attributes

Data on yield attributes have been reported in Table 4.4 and corresponding student's 't' test for these in Appendix VI and VII.

Table 4.4. Mean treatment effects on yield attributes

Crop	No. of effective tiller/branches per plant	No. of noneffective tillers/branches per plant	No. of grains per ear/pod	1000-grain weight (g)
<u>Mulch</u>				
Wheat	4.25	0.25	54.00	40.71
Barley	3.75	0.50	51.50	43.96
Linseed	3.25	0.50	8.50	9.26
Mustard	5.50	0.75	13.50	5.09
Lentil	4.25	0.75	2.25	20.66
<u>No mulch</u>				
Wheat	2.50*	0.50	42.00*	37.62
Barley	2.25*	0.75	37.75*	41.27
Linseed	1.75*	0.75	5.75*	8.41
Mustard	3.25*	1.00	10.25*	4.53
Lentil	2.50*	1.00	1.50	19.58

* Significant at 5 per cent level of probability.

4.3.1. Number of effective and noneffective tillers or branches per plant

Mulching with lantana litter resulted in producing significantly more number of effective tillers per plant in wheat and barley (Table 4.4 and Appendix VI) and more number of branches per plant in linseed, mustard and lentil, however, number of noneffective tillers per plant from mulched and unmulched plots did not differ significantly (Table 4.4).

4.3.2. Number of grains per ear or per pod

The data on number of grains per ear or per pod (Table 4.4 and Appendix VII) reveals that mulching treatment helped the plants to set more number of grains. Number of grains per ear or per pod from mulched treated plants were significantly higher than unmulched one in all the crops tried under these investigations.

4.3.3. 1000-grain weight

The results on 1000-grain weight have been shown in Table 4.4 and corresponding 't' test in Appendix VII. It is evident that in all the crops 1000-grain weight from mulched and unmulched plots remained statistically at par with each other.

4.4. Grain and straw yield

The data obtained on the grain and straw yield of various crops under the impact of different treatments are presented in Table 4.5 and Fig.4. Mulching with lantana litter markedly increased the grain and straw yields of all Rabi crops. The percentage increase in grain yield due to mulching over no mulch in wheat, barley, linseed, mustard and lentil was 31.48, 35.66, 33.68, 34.15 and 31.43 per cent, respectively and the

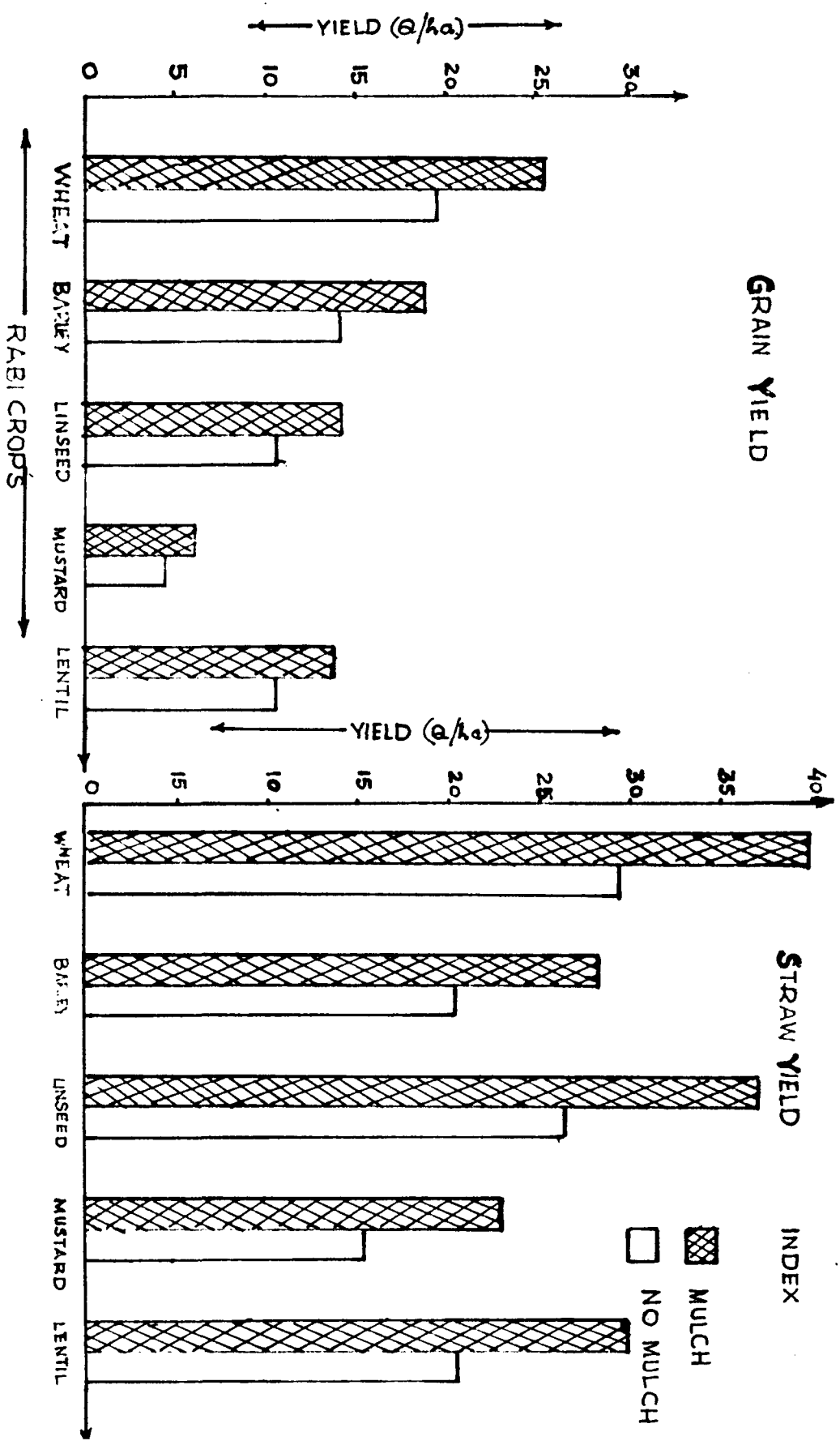

FIG. 4 TREATMENT EFFECTS ON GRAIN AND STRAW YIELD

Table 4.5. Mean treatment effects on grain and straw yield (q/ha)

Crop	Grain yield (q/ha)		Straw yield (q/ha)
		<u>Mulch</u>	
Wheat	25.18(31.48)		39.93(35.40)
Barley	18.79(35.66)		28.30(38.99)
Linseed	13.93(33.68)		37.58(44.26)
Mustard	5.97(34.15)		23.06(52.41)
Lentil	13.88(31.43)		30.54(42.31)
		<u>No mulch</u>	
Wheat	19.15		29.49
Barley	13.85		20.36
Linseed	10.42		26.05
Mustard	4.45		15.13
Lentil	10.56		21.46

Figures in parenthesis indicate the per cent increase over unmulched treatments. corresponding increments in straw yield were 35.40, 38.99, 44.26, 52.41 and 42.31 per cent, respectively.

4.5. Wheat Equivalent yield

Equivalent yields from different crops under different mulch treatments were converted by using formula (See section 3.15.6). The data thus obtained are presented in Table 4.6 and Fig.5. The analysis of variance is embodied in Appendix VIII.

4.5.1. Grain yield

Wheat equivalent grain yields of all the crops were significantly higher due to the application of lantana litter mulch (Table 4.6). In unmulched

WHEAT EQUIVALENT YIELD

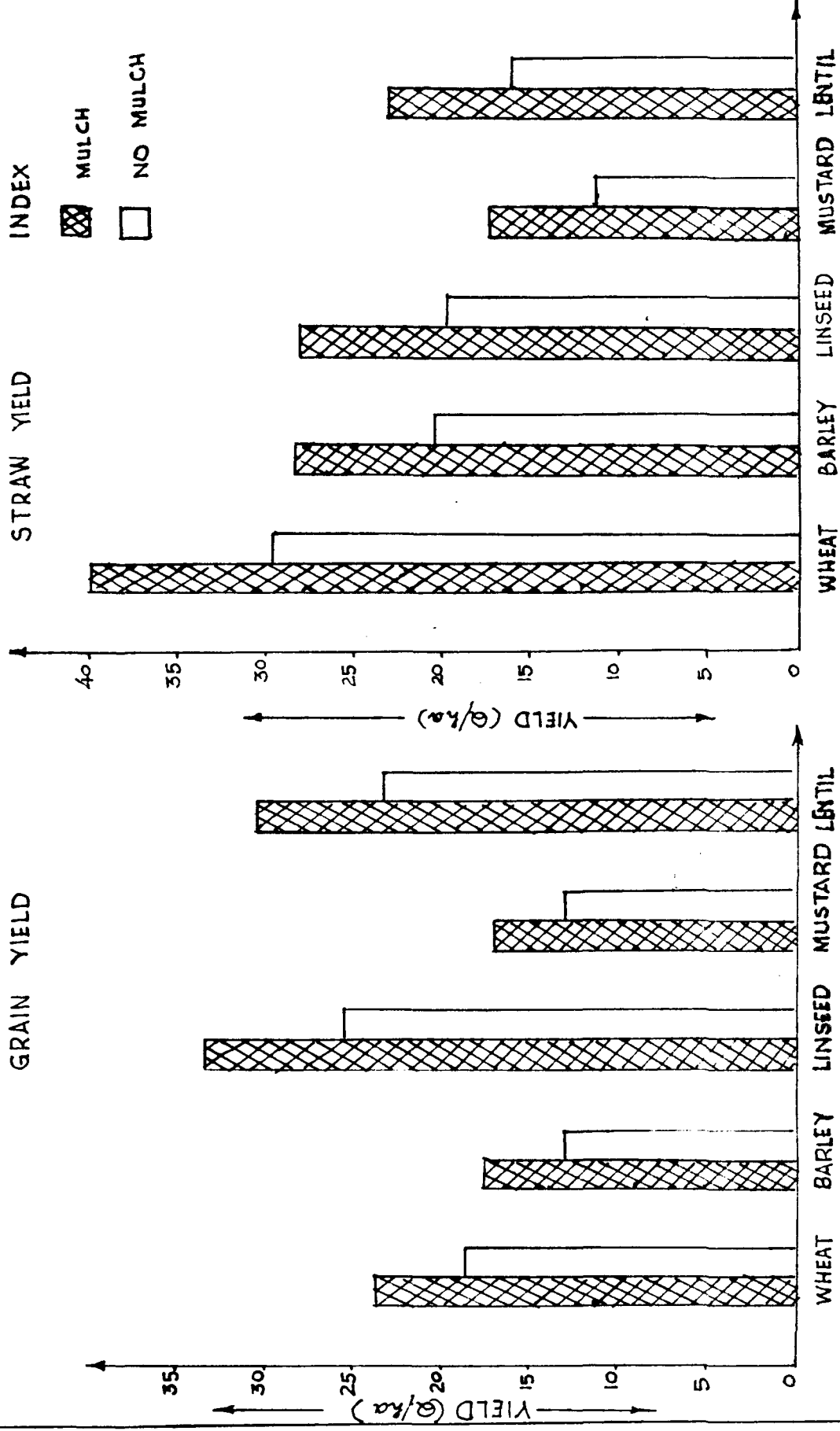

FIG-5. TREATMENT EFFECTS ON WHEAT EQUIVALENT YIELD OF RABI CROPS

plots wheat equivalent grain yield of linseed was highest followed by lentil which in turn was significantly more than that of wheat. Wheat equivalent yields from barley and mustard were statistically at par with each other but were significantly less than that of wheat. However, in unmulched plots trend was different. Highest value was obtained from linseed and lentil both being at par with each other, followed by wheat which in turn was significantly more than that of barley and mustard. The percentage increase in wheat equivalent grain yield due to mulching over no mulch is highest in barley (35.66%) and lowest in wheat (27.01%). The per cent increase over control in lentil, linseed and mustard was 31.42, 33.68 and 34.31, respectively. CD for interaction is not calculated because the interaction is non-significant.

Table 4.6. Mean treatment effects on wheat equivalent grain and straw yield(q/ha)

Crops	Grain yield(q/ha)		Straw yield(q/ha)	
	No mulch	Mulch	No mulch	Mulch
Wheat	13.84	23.93 (27.01)	29.49	39.93(35.40)
Barley	13.01	17.65 (35.66)	20.36	28.30(39.00)
Linseed	25.26	33.77 (33.68)	19.53	28.18(44.29)
Mustard	12.94	17.38(34.31)	11.34	17.29(52.46)
Lentil	23.36	30.70(31.42)	16.09	22.90(42.32)
SE _m for crops		1.79		1.83
CD _{5%} for crops		3.06		3.11
SE _m for mulch		1.13		1.15
CD _{5%} for mulch		1.93		1.97

Figures in parenthesis indicate the per cent increase over no mulch treatments.

4.5.2. Straw yield

In mulched plots wheat equivalent straw yields was highest in case of wheat followed by barley and linseed which were at par with each other but significantly more than that of mustard and lentil. Mustard and lentil plots treated with lantana litter failed to exhibit any significant difference with respect to wheat equivalent straw yield. The pattern in unmulched plots was more or less similar except that in yield from lentil was significantly more than that of mustard. The per cent increase of wheat equivalent straw yield of mulched plot over no mulch treatments was highest (52.46) in mustard and lowest (35.40) was recorded in wheat. The per cent increase of wheat equivalent straw yields in case of other crops were 39.00, 44.29 and 42.32 in barley, linseed and lentil.

4.6. Seasonal Crop Water Use Studies

Depthwise seasonal water use as influenced by various treatments have been presented in Fig.6, 7, 8, 9, 10 and corresponding values of seasonal water use at different growth stages have been given in Appendix section (Appendix IX, X, XI, XII, and XIII, respectively).

As is apparent from Fig.6 and Table 4.7 in wheat seasonal water use under mulched and no mulch plots revealed a sigmoid trend, increased from 30 DAS upto 120 DAS and then slightly decreased upto harvest both at 0-20 and 20-40 cm depths. However, in deeper profile (40-60 cm) the increase was observed upto 150 DAS and then there was a decline in moisture use (Fig.6 and Appendix IX). A close perusal of the Fig.6 indicates that in shallow depths (0-20 cm) water use from mulched and unmulched plots was more or less same, however, in 20-40 cm depth, interestingly at 90 DAS, water use

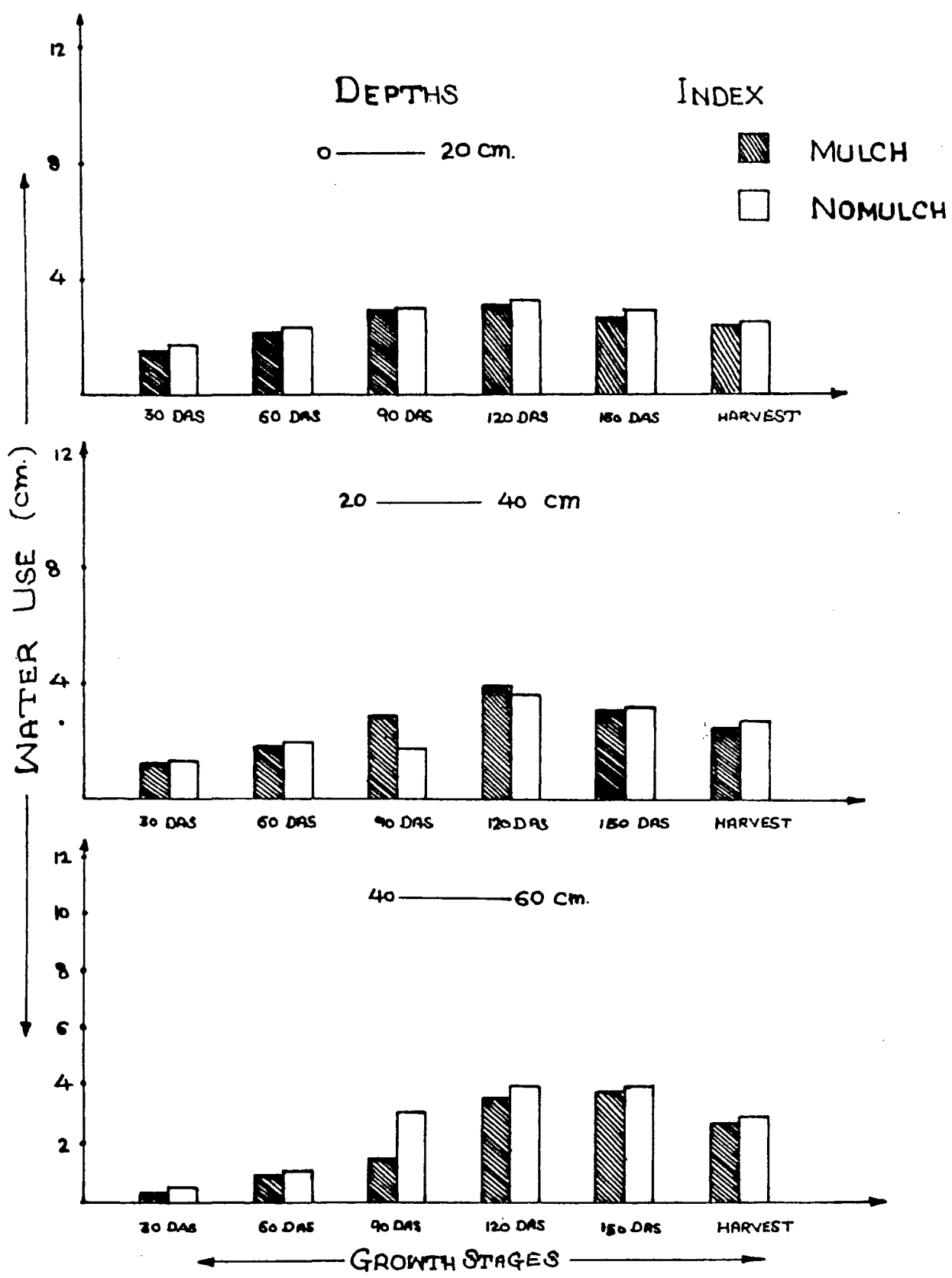

SEASONAL WATER USE — WHEAT CROP.

FIG-6

Table 4.7. Mean treatment effects on depthwise and stagewise seasonal water use (cm) - wheat crop

Treatments	Depth	Days after sowing						Cumulative
		30	60	90	120	150	At harvest	
Mulch	0-20cm	1.48	2.12	2.89	3.06	2.65	2.37	14.51
	20-40cm	1.23	1.87	2.97	3.89	3.14	2.49	15.59
	40-60cm	0.27	0.94	1.54	3.62	3.89	2.74	13.00
Total	0-60 cm	2.98	4.93	7.40	10.57	9.68	7.54	43.10
No mulch	0-20cm	1.59	2.28	2.93	3.11	2.71	2.37	14.98
	20-40cm	1.31	1.96	1.80	3.72	3.19	2.58	14.56
	40-60cm	0.37	1.03	3.15	4.03	3.95	2.86	15.39
Total	0-60cm	3.26	5.27	7.88	10.86	9.85	7.81	44.93

from mulched treatments was markedly higher than unmulched counterpart, recording almost similar values at 30 DAS, 60 DAS, 120 DAS, 150 DAS and at harvest. In 40-60 cm depth, trend was same as in 0-20 cm except at 90 DAS where no mulched plots recorded sufficiently higher values (3.15 cm) in comparison to mulched one (1.54 cm). At harvest, water use from no mulch plots remained slightly higher than mulched plots in all the depths.

Barley:

Water use by barley crop depthwise and stagewise has been shown in Fig.7 and Table 4.8 and corresponding analysis of variance has been appended in Appendix X.

The pattern of water use revealed by barley was somewhat different from that of wheat. At 30 DAS of barley water use from unmulched fields was

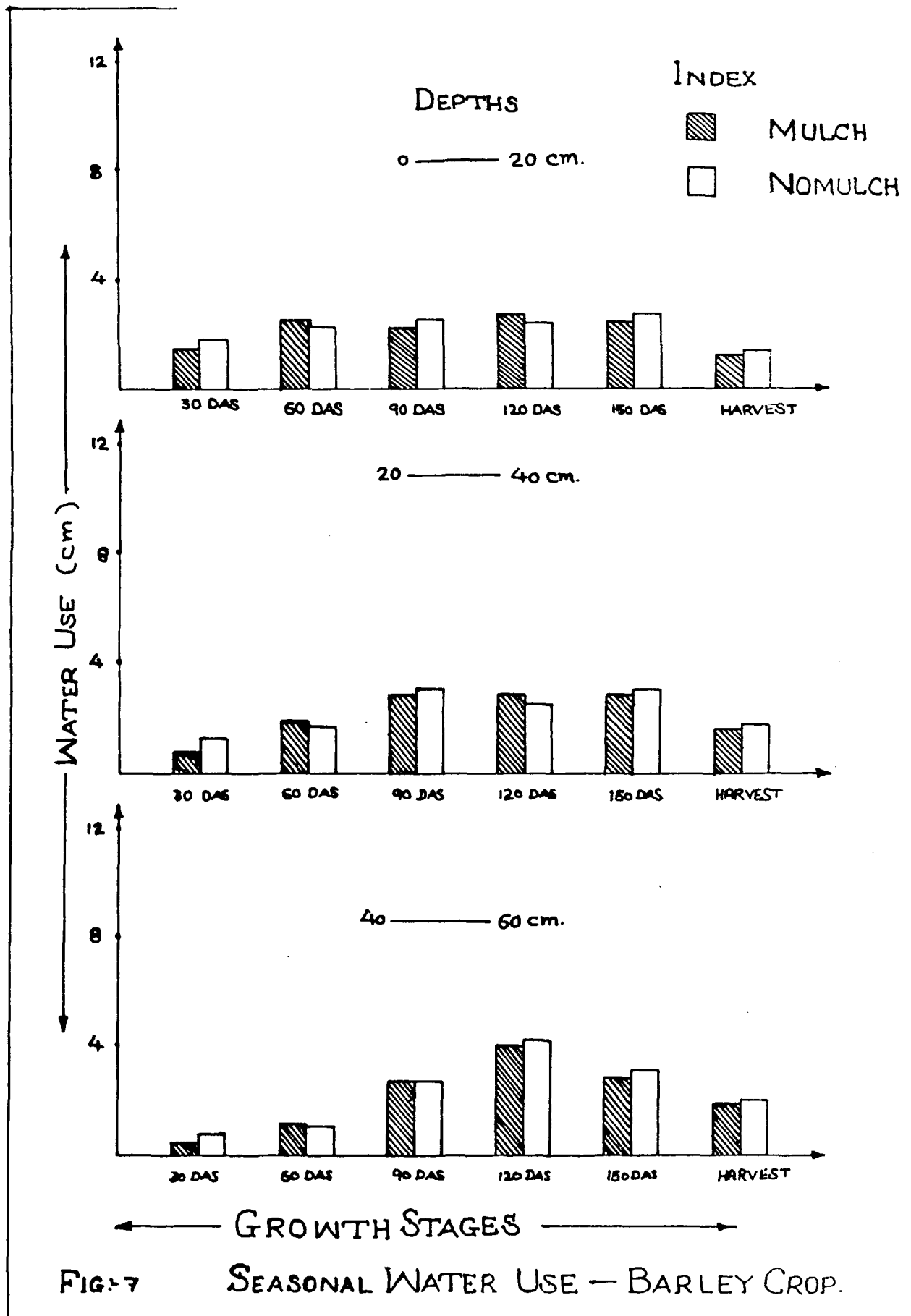

higher than from mulched ones at all the depths and the trend being reverse at 60 DAS stage, whereas at 90 DAS growth stage trend being similar as that of at 30 DAS stage except in deeper layer (40-60 cm), where both mulched and unmulched treatments recorded the same value.

Table 4.8. Mean treatment effects on depthwise and stagewise seasonal water use (cm) - barley crop

Treatments	Depth	Days after sowing					At harvest	Cumulative
		30	60	90	120	150		
Mulch	0-20cm	1.55	2.43	2.18	2.63	2.45	1.32	12.56
	20-40cm	0.80	1.85	2.92	2.87	2.96	1.63	13.03
	40-60cm	0.41	1.07	2.71	2.98	2.80	1.89	11.65
Total	0-60cm	2.76	5.35	7.81	8.48	8.21	4.84	37.25
No mulch	0-20cm	1.87	2.34	2.53	2.39	2.73	1.39	13.25
	20-40cm	1.27	1.79	3.05	2.53	2.99	1.68	13.31
	40-60cm	0.79	1.05	2.72	3.15	3.01	1.95	12.67
Total	0-60cm	3.93	5.18	8.30	8.07	8.73	5.02	39.23

At 120 DAS stage mulched plots used more water than unmulched ones by 2.4 mm in 0-20 cm depth and by 3.4 mm in 20-40 cm, recording more or less same value at lowest depth. At 150 DAS growth stage as well as at harvest water used was just like that of wheat as more from no mulched plots than mulched ones.

Linseed

Results on water use values related to linseed crop presented through Fig.8 and Table 4.9 have been appended in Appendix XI. At 30 and 60 DAS no mulched plots recorded higher water use values than mulched ones at all the depths studied in the present investigation.

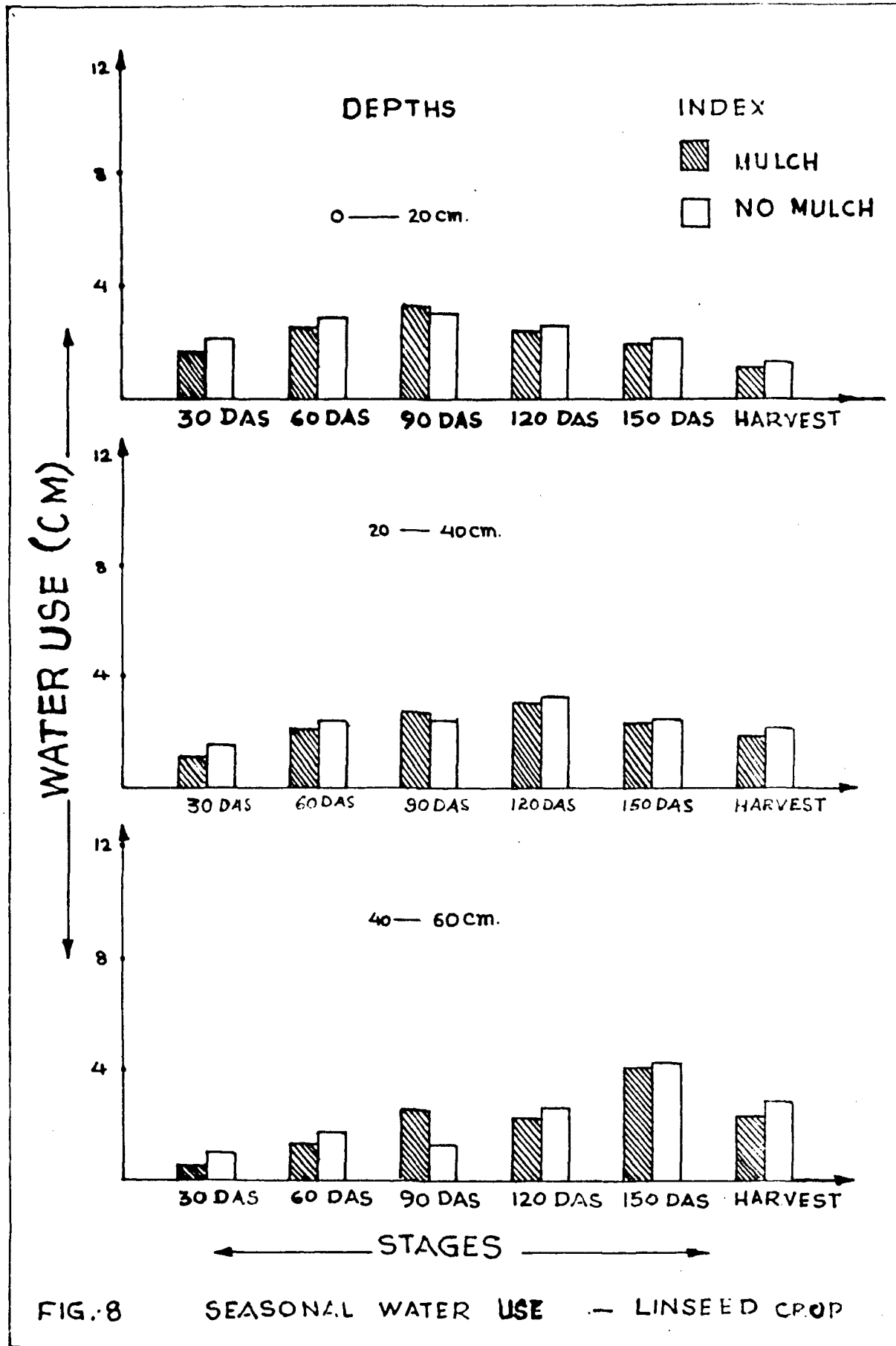

FIG. 8 SEASONAL WATER USE — LINSEED CROP

Table 4.9. Mean treatment effect on depthwise and stage-wise seasonal water use (cm) - linseed crop

Treatment	Depth	Days after sowing					At harvest	Cumulative
		30	60	90	120	150		
Mulch	0-20cm	1.69	2.59	3.15	2.43	1.98	1.08	12.92
	20-40cm	1.07	2.06	2.61	3.05	2.27	1.81	12.87
	40-60cm	0.56	1.33	2.48	2.25	3.06	2.35	12.03
Total	0-60cm	3.32	5.98	8.24	7.73	7.31	5.24	37.82
No mulch	0-20cm	2.11	2.89	2.97	2.45	2.03	1.15	13.60
	20-40cm	1.45	2.37	2.29	3.17	2.34	2.12	13.74
	40-60cm	0.97	1.73	1.23	2.60	3.17	2.89	12.59
Total	0-60cm	4.53	6.99	6.49	8.22	7.54	6.16	39.93

However, the trend was just opposite at 90 DAS at all the depths. The pattern was again similar at 120 DAS growth stage and 150 DAS and at harvest also under all the depths. At harvest water use from unmulched plots was same in 0-20 cm, higher by 3.1 mm in 20-40 cm and by 5.4 mm in 40-60 cm depth indicating thereby that effectiveness of mulch material was more realised in deeper soil layers as compared to sub-soil layers.

Mustard

The pattern of water use by mustard crop has been depicted in Fig. 9 and corresponding values of moisture use in Table 4.10 and Appendix XII.

At 30 and 60 DAS amount of water used in no mulched plots remained higher than mulched plots in all the depths i.e. 0-20cm, 20-40cm and 40-60cm. However, at 90 DAS all the depths revealed reverse trend i.e. mulched plots utilized higher quantity of water than unmulched one.

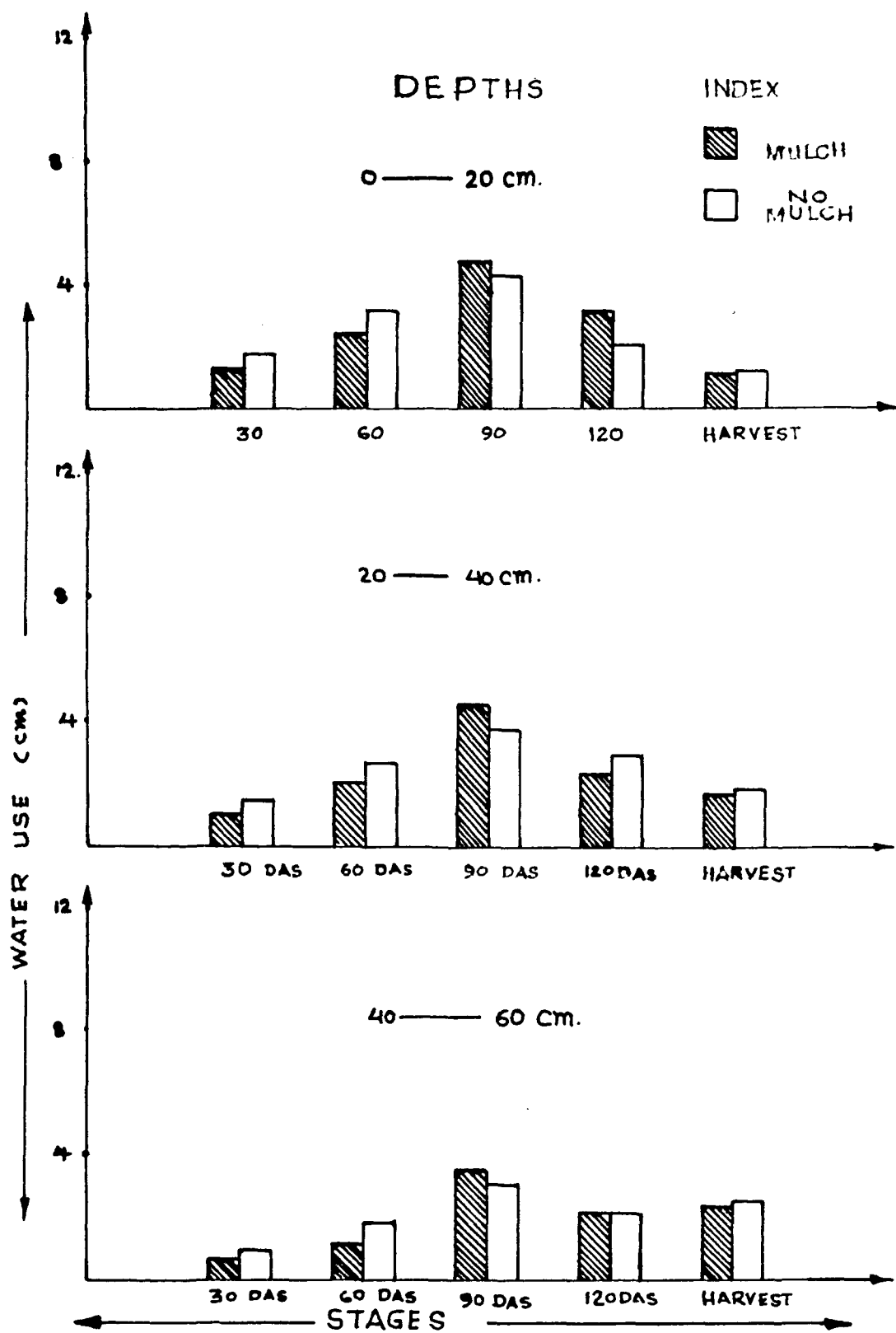

FIG. 9 SEASONAL WATER USE — MUSTARD CROP

Table 4.10. Treatment effects on depthwise and stagewise seasonal water use (cm) - Mustard crop

Treatment	Depth	Days after sowing				At harvest	Cumulative
		30	60	90	120		
Mulch	0-20cm	1.23	2.37	4.71	3.09	1.15	12.55
	20-40cm	1.05	2.01	4.57	2.34	1.69	11.66
	40-60cm	0.61	1.15	3.46	2.13	2.38	9.73
Total	0-60cm	2.89	5.53	12.74	7.56	5.22	33.94
No mulch	0-20cm	1.79	3.17	4.23	2.01	1.19	12.39
	20-40cm	1.45	2.63	3.75	2.93	1.74	12.50
	40-60cm	0.94	1.81	3.07	2.10	2.44	10.36
Total	0-60cm	4.18	7.61	11.05	7.04	5.37	35.25

After 120 DAS water used by mulch treated fields was higher than 0-20 cm, less than 20-40 cm unmulched plots and same as unmulched ones (40-60 cm). At harvest water used was more or less same at all the depths.

Lentil

The trend of water used by lentil crop during its growth cycle has been depicted through Fig.10 and Table 4.11. The corresponding analysis of variance has been given in Appendix XIII.

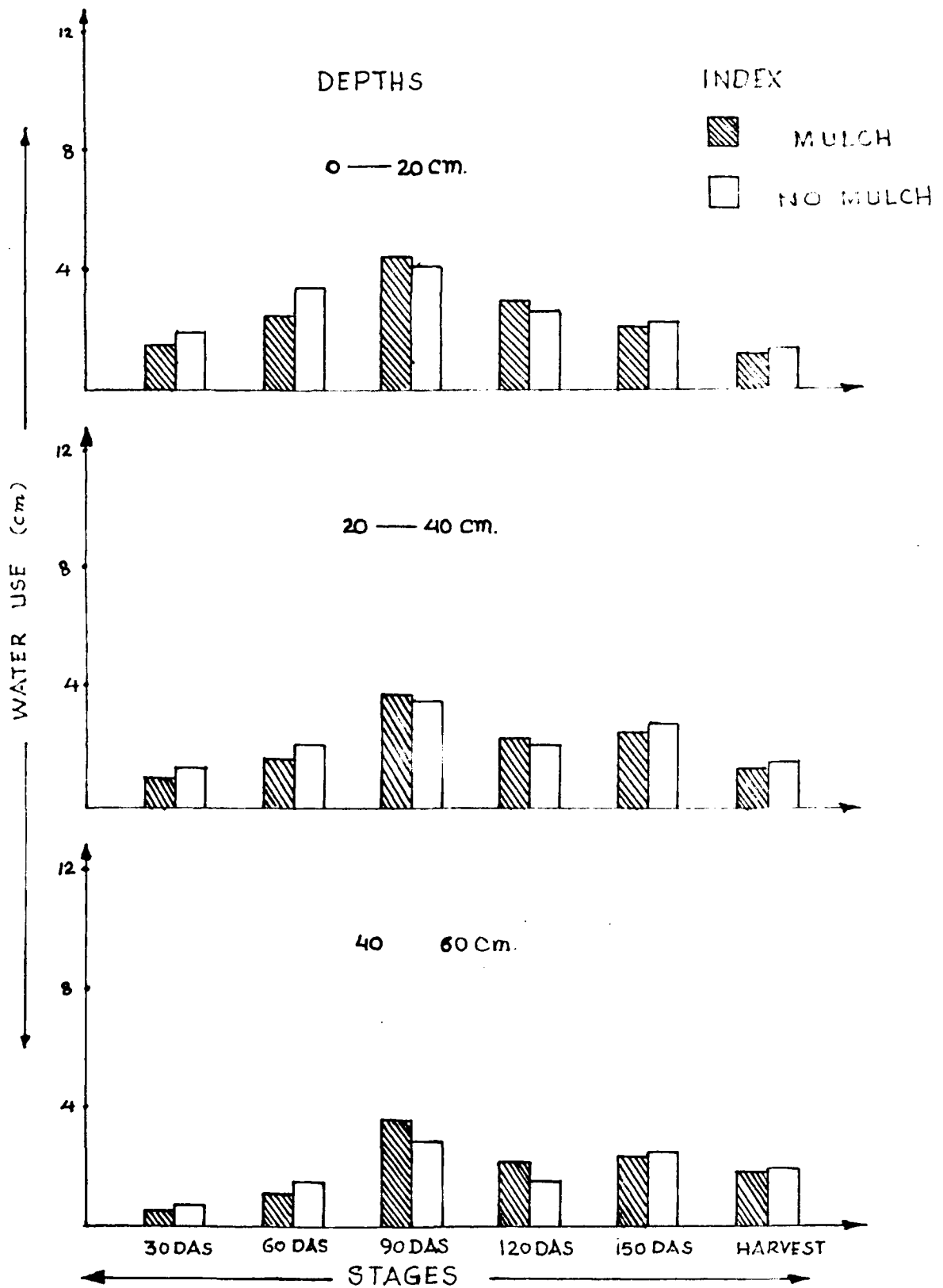

FIG. 10 SEASONAL WATER USE — LENTIL CROP

Like mustard crop in all the depths studied at 30 and 60 DAS stages the amount of water used in unmulched treatments was more than mulched ones whereas trend was just reverse at 90 DAS and 120 DAS.

Table 4.11. Mean treatment effects on depthwise and stagewise seasonal water use (cm) - Lentil crop

Treatment	Depth	Days after sowing					At harvest	Cumulative
		30	60	90	120	150		
Mulch	0-20cm	1.58	2.47	4.39	2.89	2.11	1.17	14.61
	20-40cm	0.98	1.63	3.67	2.25	2.56	1.39	12.48
	40-60cm	0.46	1.08	3.63	2.15	2.37	1.92	11.61
Total	0-60cm	3.02	5.18	11.69	7.29	7.04	4.48	38.70
No mulch	0-20cm	1.88	3.43	4.17	2.76	2.24	1.23	15.71
	20-40cm	1.28	2.07	3.53	2.09	2.74	1.47	13.18
	40-60cm	0.76	1.44	2.85	1.49	2.43	1.96	10.93
Total	0-60cm	3.92	6.94	10.55	6.34	7.41	4.66	39.82

At 150 DAS and at harvest quantity of water used by mulched and unmulched plots remained more or less same at all the depths.

4.7. Depthwise and stagewise per cent soil moisture contribution of different crops

Wheat

Depthwise seasonal water use by wheat at different stages of the growth cycle has been depicted in Fig.12 and appended in Appendix IX. In mulched as well as unmulched treatments, the total moisture contribution increased

FIG. (OUT) SIDE LEFT = % MOISTURE CONTRIBUTION OF VARIOUS DEPTHS
 RIGHT SIDE = % CONTRIBUTION SEASONAL WATER USE
 WITH IN BAR = QUANTUM OF WATER UTILISED IN CM
 SOIL DEPTH = FROM TOP TO BOTTOM

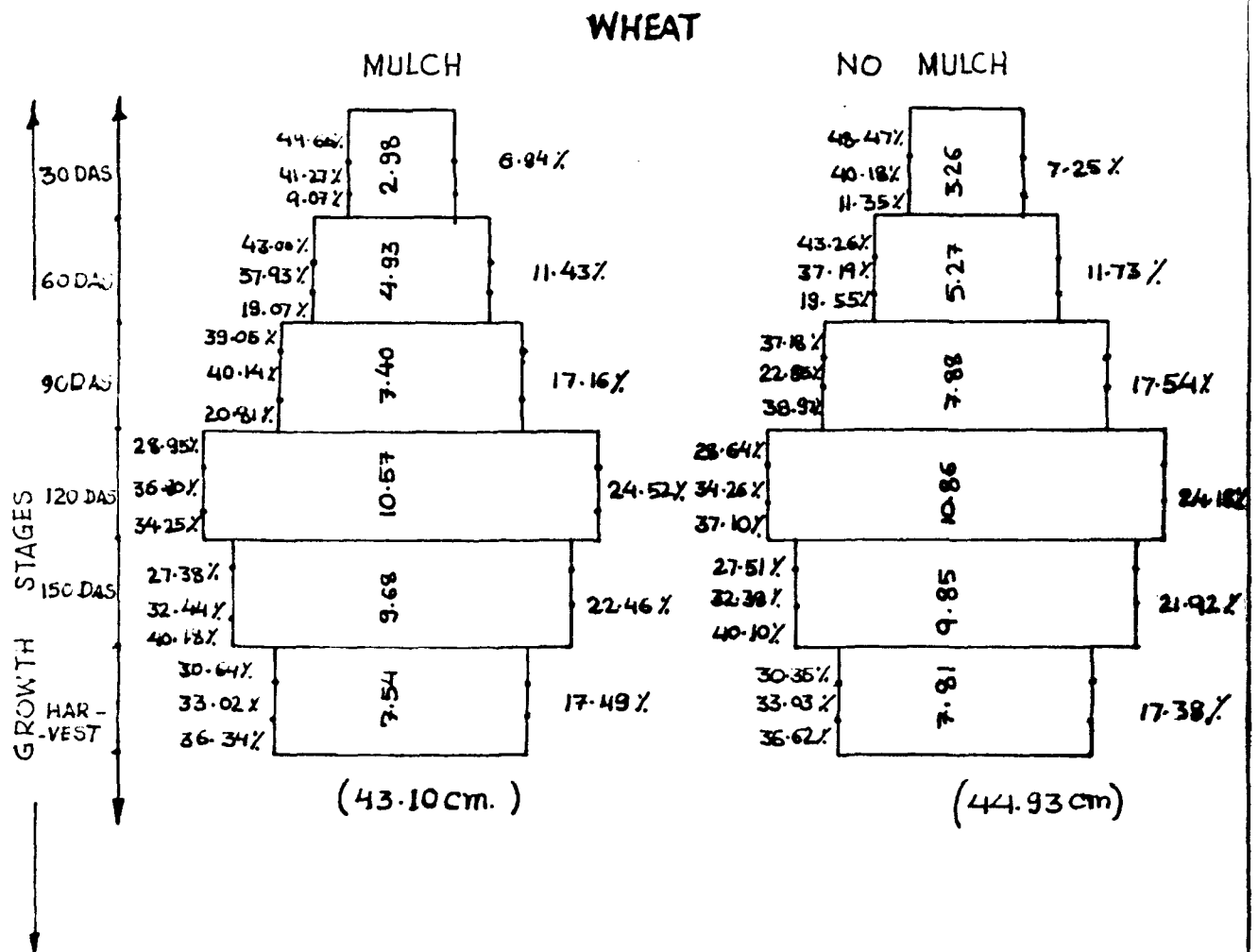

FIG. 12 DEPTH WISE SEASONAL WATER USE (CM) AT DIFFERENT CROP GROWTH STAGES - WHEAT

from 30 DAS till 120 DAS and then declined at 150 DAS towards harvest. The maximum total moisture contribution was recorded at 120 DAS both under mulched (24.5%) and unmulched (24.1%) plots. In mulched plots, as is evident from Fig.12, per cent moisture contribution was higher from upper soil profile (0-20 cm and 20-40 cm) during early growth stages, however, later on at 120 DAS, 150 DAS and at harvest the trend was somewhat reverse. Under no mulch treatment such a pattern was not that much definite. One thing evidently proved from the figure is that at all the stages of growth the per cent value of moisture contribution from no mulch treatment remained higher than that from mulched one. At shallow and deeper soil depths fluctuations in soil moisture contribution from 30 DAS till harvest were comparatively more than 20-40 cm soil depth and this was true both for mulched as well as unmulched treatments. At harvest per cent moisture contribution from all the soil profiles was more or less same in mulched as well as unmulched plots.

Barley

Depthwise seasonal water use by barley crop (mulched and unmulched) has been diagrammatically presented in Fig.13 (Appendix X). Under mulched conditions, as a whole, per cent moisture contribution revealed an increasing trend right from 30 DAS till 120 DAS, following a slight decline at 150 DAS and afterwards there was a marked decrease from 22.04 per cent at 150 DAS to 12.98 per cent at harvest. During early growth stages (30 DAS and 60 DAS), lower values of per cent moisture contribution were noticed from lower soil horizons (40-60 cm) whereas during later growth stages (150 DAS and at harvest) lower values of per cent moisture contribution were associated with upper soil

FIG. (OUT) SIDE LEFT = % MOISTURE CONTRIBUTION AT VARIOUS DEPTHS
 RIGHT SIDE = % CONTRIBUTION SEASONAL WATER USE
 WITHIN BAR = QUANTUM OF WATER UTILISED IN CM
 SOIL DEPTH = FROM TOP TO BOTTOM
BARLEY

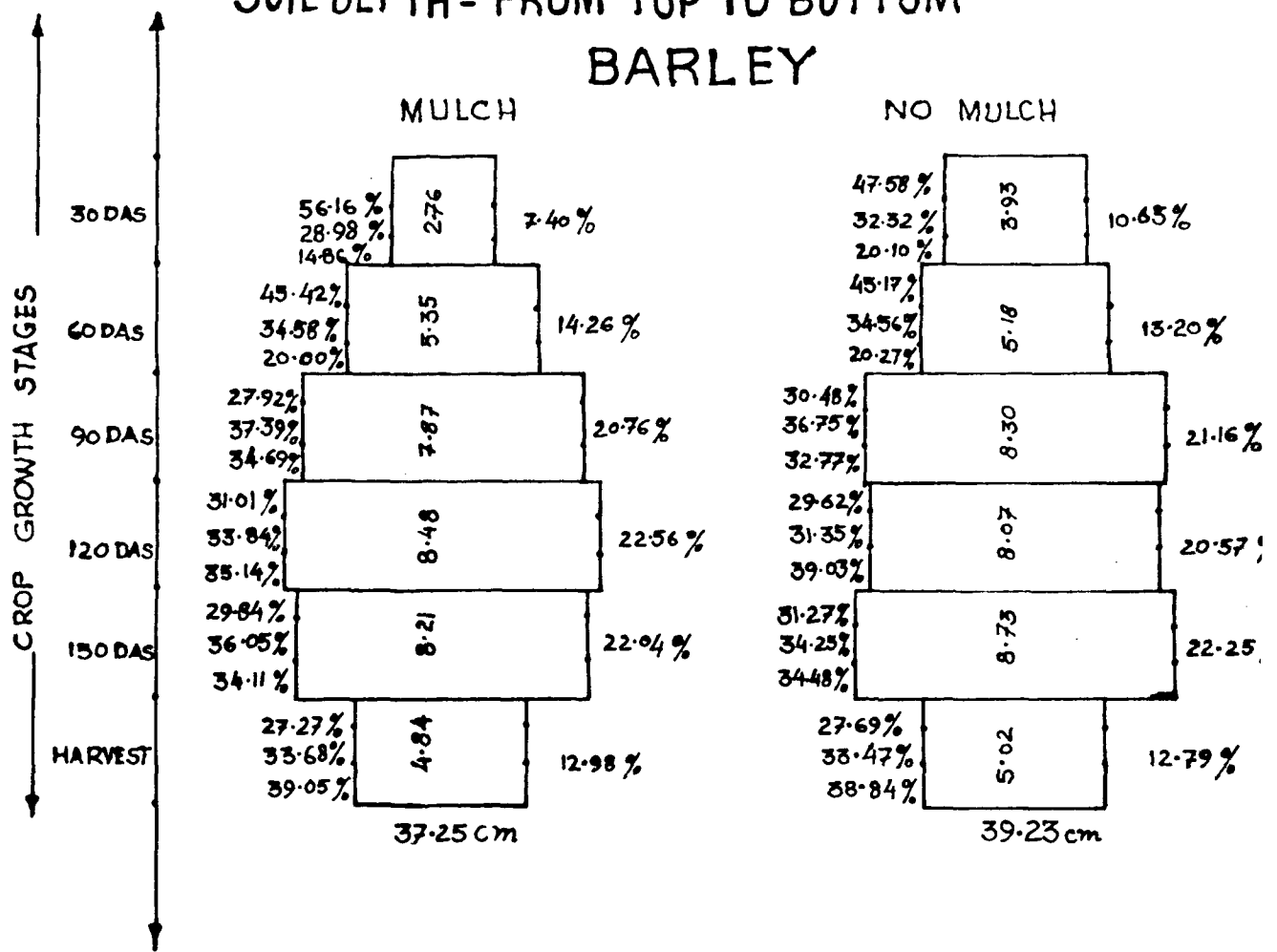

FIG. 13. DEPTH WISE SEASONAL WATER USE (CM) AT
 DIFFERENT CROP GROWTH STAGES - BARLEY

profile (0-20 cm). In soil depth from 20-40 cm the variations in moisture contribution were not that much pronounced ranging from 28.98 per cent at 30 DAS to 37.39 per cent at 90 DAS. Unlike mulch treatments, from no mulch plots, an increase in per cent contribution was recorded from 30 DAS till 150 DAS. The per cent moisture contribution of total seasonal water use at 30, 60, 90, 120 and 150 DAS growth stages were 10.03, 13.20, 21.16, 20.57 and 22.25 per cent, respectively. At harvest there was a sharp decline to 12.79 per cent. At 30 DAS and at 60 DAS upper soil layers (0-20 cm) exhibited higher per cent moisture contribution whereas at other crop growth stages (90 DAS, 120 DAS, 150 DAS and at harvest) upper soil profile recorded lowest values and at these stages highest values were associated with 40-60 cm soil depth. In soil layers from 20-40 cm just like mulched plots, fluctuations in soil moisture contribution were comparatively less varying from 31.35 per cent at 120 DAS and 34.56 per cent at 60 DAS crop growth stages.

Comparing mulch and no mulch treatments as a whole, total moisture contribution from no mulch plots was higher than mulched ones. Moisture contribution at 30 DAS was more from no mulch plots and at other stages these values were more or less the same.

Linseed

Per cent depthwise seasonal water use by linseed crop has been depicted through Fig. 14 and appended in Appendix XI. Quantum of water utilized was found to be highest at 90 DAS (21.79%) under mulched plots and 120 DAS (20.58%) under no mulch plots. The per cent moisture contribution revealed an increasing trend from 30 DAS till 120 DAS and then it declined till harvest. Lowest values were recorded at harvest both under mulched (13.85%) and unmulched (15.43%) conditions.

FIG.(OUT) SIDE LEFT= % MOISTURE CONTRIBUTION AT VARIOUS DEPTH
 RIGHT SIDE % CONTRIBUTION SEASONAL WATER USE
 WITHIN BAR=QUANTUM OF WATER UTILISED IN (CM)
 SOIL = FROM TOP TO BOTTOM

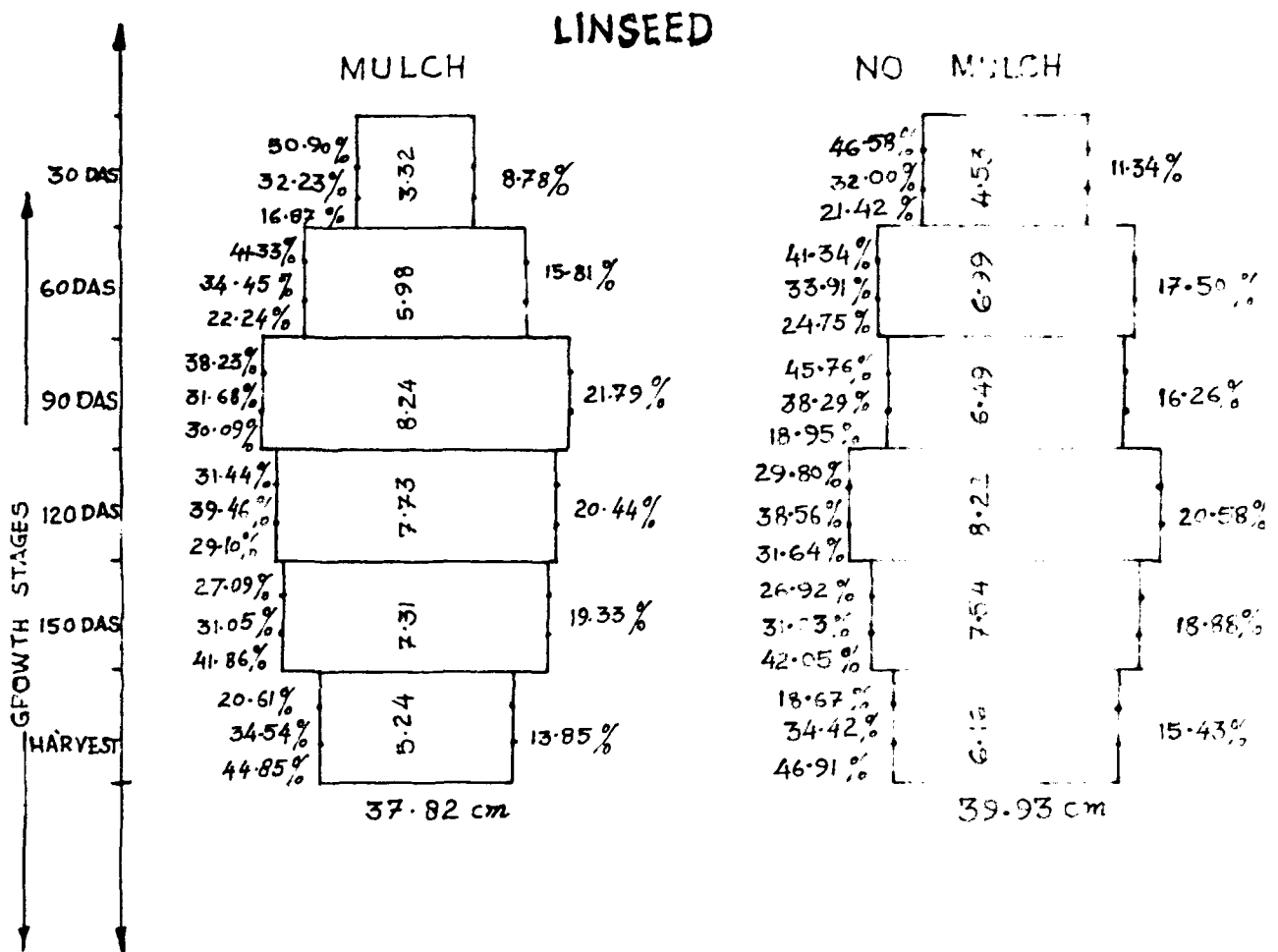

FIG. 14 DEPTHWISE SEASONAL WATER USE (CM) AT
 DIFFERET CROP GROWTH STAGES - LINSEED

During early growth stages i.e. 30 and 60 DAS, particularly under mulch treatment highest per cent contribution of moisture was from shallow soil layers which is 50.90 and 41.33 per cent, respectively and with the advancement of growth the trend appeared to just opposite. At harvest maximum moisture contribution was from 40-60 cm soil depth i.e. 44.85 per cent. More or less similar trend was observed under no mulch treatments except that shallow soil layers i.e. 0-20 cm continued to contribute markedly higher moisture than lower layers upto 90 DAS. At the time of harvesting per cent moisture contribution from 0-20, 20-40 and 40-60 cm was 18.67, 34.42 and 46.91 per cent, respectively.

Mustard

Data with respect to depthwise and stagewise per cent moisture contribution by mustard crop have been presented graphically in Fig. 15 and appended in Appendix XII. Highest per cent contribution of seasonal water use was at 90 DAS both under mulched and unmulched conditions. The per cent contribution at 90 DAS was 34.54 and 31.36 per cent under mulch and no mulch treatments respectively. In mulched as well as unmulched plots per cent moisture contribution showed an increasing trend from 30 DAS till 90 DAS and then it decline till harvest.

Under mulched plots highest contribution was observed to be from shallow soil layers at almost all the stages except at harvest. At harvest lowest layers contributed significantly more than upper ones i.e. 45.59%.

Similar trend was observed under no mulch treatments. At 120 DAS highest contribution was from 20-40 cm soil depth (41.62%) whereas at harvest 40-60 cm soil layers contributed markedly (i.e. 45.42%).

FIG. (OUT) SIDE LET = % MOISTURE CONTRIBUTION AT VARIOUS DEPT I
 RIGHT SIDE = % CONTRIBUTION SEASONAL WATER USE
 WITHIN BAR = QUANTUM OF WATER UTILISED (CM)
 SOIL DEPTH = FROM TOP TO BOTTOM
 MUSTARD

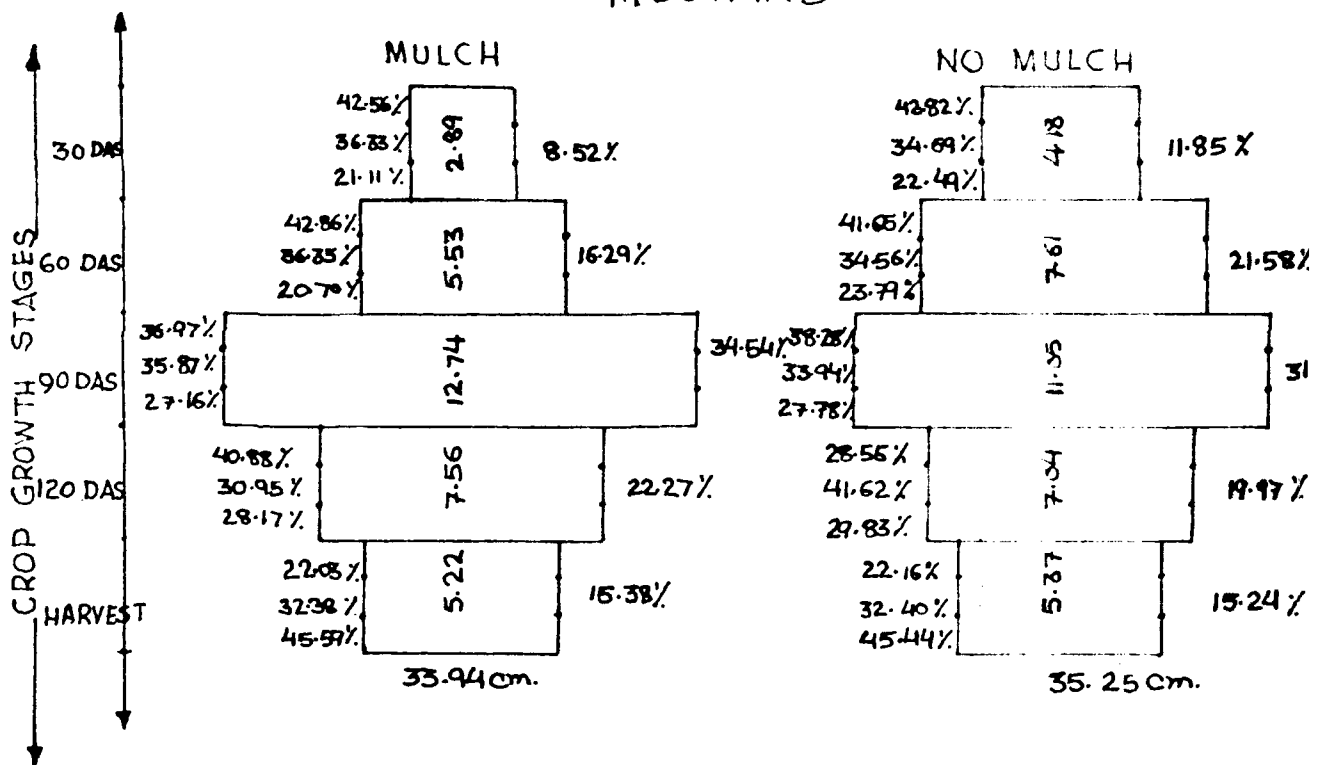

FIG. 15 DEPTH WISE SEASONAL WATER USE (CM) AT
 DIFFERENT CROP GROWTH STAGES - MUSTARD

Lentil

Depthwise and stagewise per cent water contribution pattern by lentil crop has been depicted in Fig.16 and appended in Appendix XIII. Highest moisture contribution was noticed at 90 DAS crop growth stages both under mulched as well as unmulched treatments 30.22 and 26.49 per cent, respectively. The trend of moisture contribution was just like other crops i.e. an increase from 30 DAS to 90 DAS and then decline upto harvest under mulched and unmulched conditions.

Depthwise variations in per cent moisture contribution were reflected only by shallow and deeper soil profile. The contribution from 20-40 cm soil depth remained more or less same at all the stages of crop growth. This was true for both the treatments. Interestingly at harvest lower layers contributes more moisture whereas shallow soil layers played a significant role for moisture contribution during early stages of crop growth. The per cent moisture contribution at early stages i.e. 30 DAS and 60 DAS was more from the upper layer (0-20cm) i.e. 52.31, 47.68, 47.96 and 49.42 under both mulch and no mulch treatments, respectively, whereas at harvest in both the condition the per cent moisture contribution was more from deeper layer (40-60cm) i.e. 42.85 and 42.06, respectively.

4.8. Crop Water Expense Studies

4.8.1. Total water expense

The total water expense values were calculated by summing up the profile moisture use and total effective rainfall during the crop growth season. The data with respect to total water expense under different treatments have been presented in Table 4.12 and Fig.11.

FIG. (OUT)SIDE LEFT = % MOISTURE CONTRIBUTION AT VARIOUS DEPTHS
 RIGHT SIDE = % CONTRIBUTION SEASONAL WATER USE
 WITHIN BAR = QUANTUM OF WATER UTILISED (CM)
 SOIL DEPTH = FROM TOP TO BOTTOM

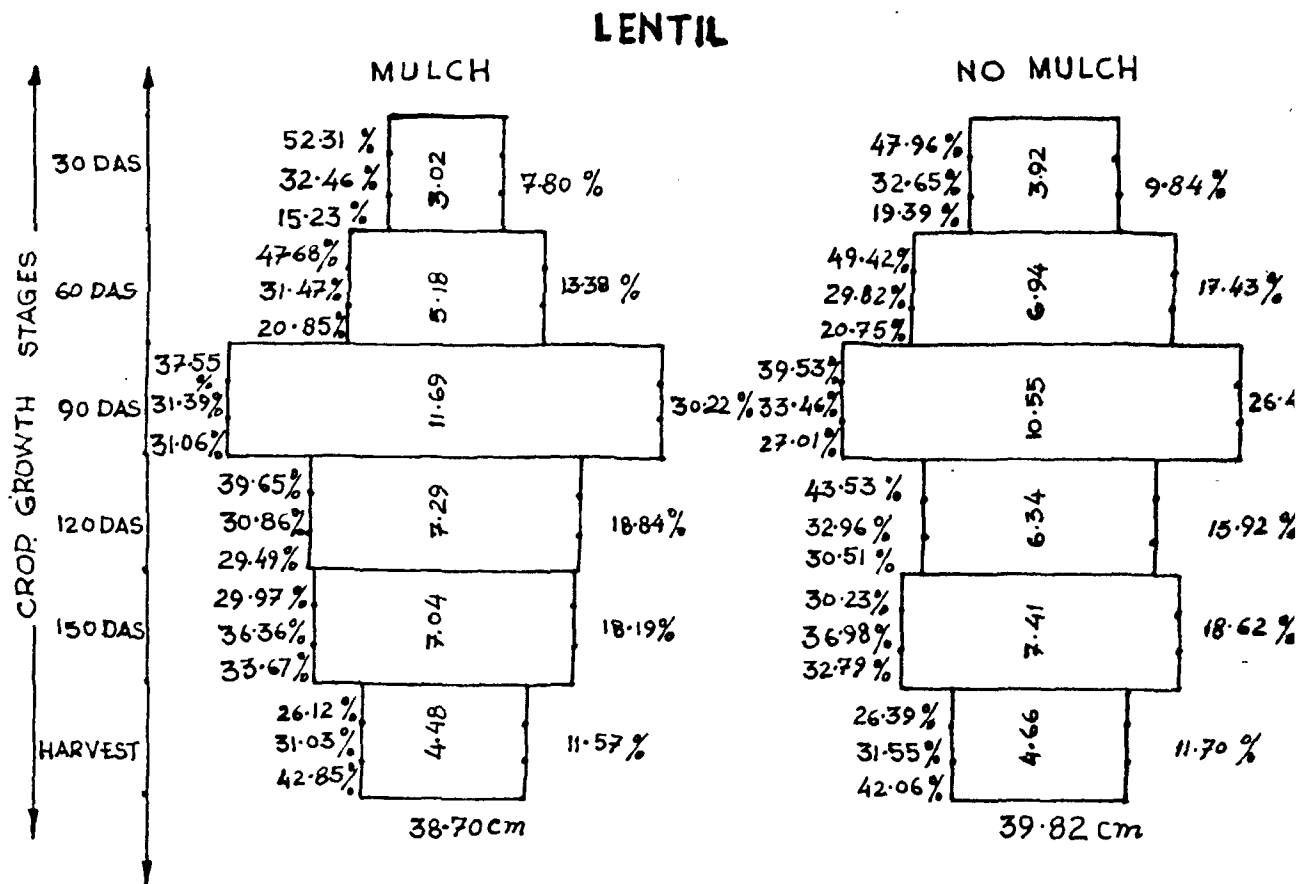

FIG. 16 DEPTHWISE SEASONAL WATER USE (CM) AT
 DIFFERENT CROP GROWTH STAGES - LENTIL

Table 4.12. Treatment effects on total water expense during crop growth period (cm)

Treatment	Soil moisture at sowing (0-60 cm)	Left over soil moisture at harvest (cm)	Profile moisture use (cm)	Effective* rainfall (cm)	Total water expense (cm)
<u>Mulch</u>					
Wheat	19.40	16.70	2.70	40.40	43.10
Barley	19.40	17.45	1.95	35.30	37.25
Linseed	19.40	17.33	2.02	35.80	37.82
Mustard	19.40	13.96	0.44	33.50	33.94
Lentil	19.40	16.20	3.20	35.50	38.70
<u>No mulch</u>					
Wheat	19.40	14.87	4.53	40.40	44.93(4.24)
Barley	19.40	15.47	3.93	35.30	39.23(5.31)
Linseed	19.40	15.27	4.13	35.80	39.93(5.57)
Mustard	19.40	17.61	1.75	33.50	35.25(3.85)
Lentil	19.40	15.08	4.32	35.50	39.82(2.89)

*Different figures for effective rainfall for different crops was due to different crops life span.

Figures in parenthesis indicate per cent increase of water expense over mulched treatments.

Total water expense was less in mulched treatments as compared to no mulch treatment and this was true for all the crops. Per cent increase in total water expense from no mulched plots over mulched ones was to the tune of 4.24, 5.31, 5.57, 3.85 and 2.89 for wheat, barley, linseed, mustard and lentil, respectively.

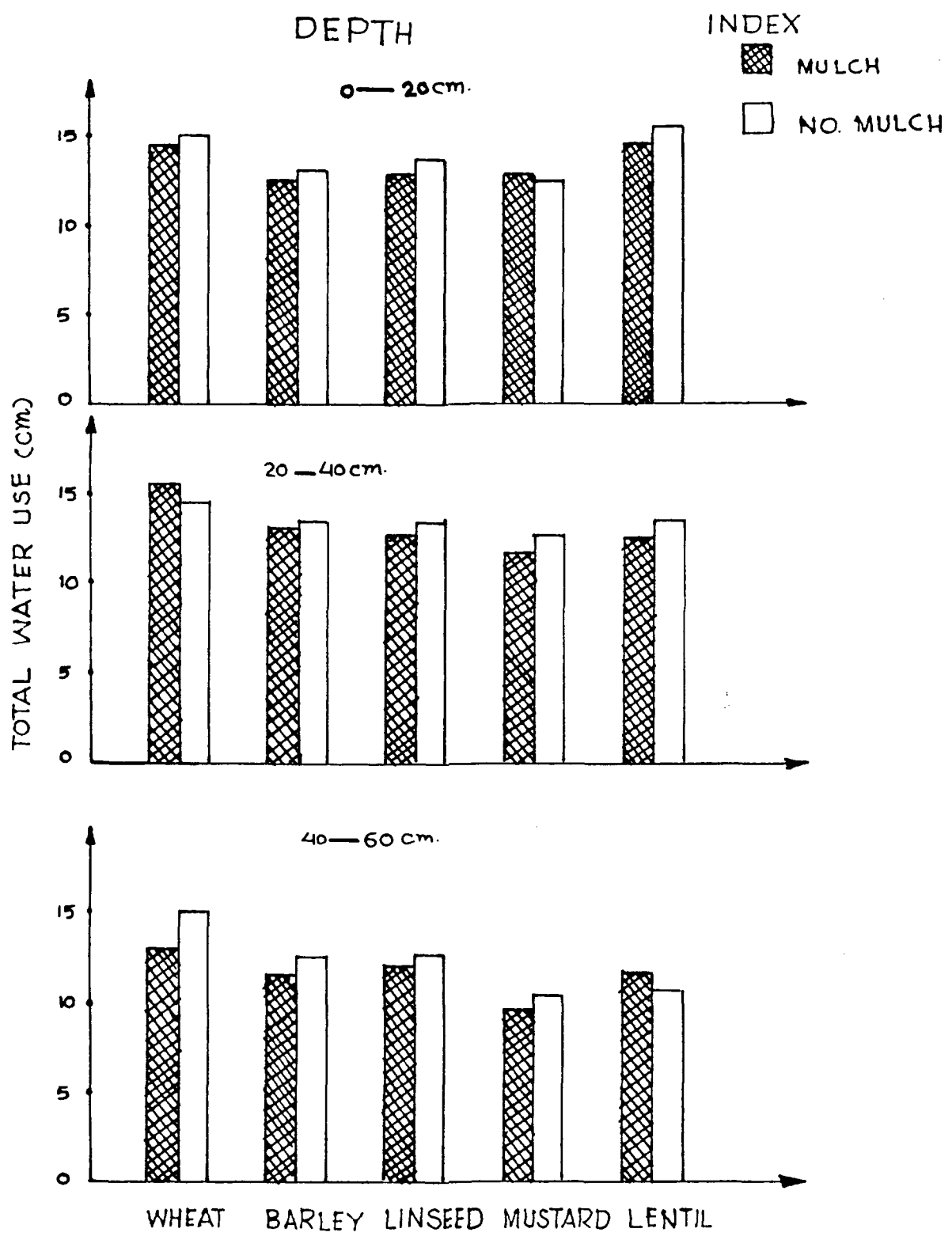

FIG.11 TOTAL GROWTH PERIOD WATER USE OF RABI CROP

Among various crops highest value of total water expense was recorded from wheat crop and minimum for mustard both under mulched and unmulched plots, other crops showed intermediate kind of water expense.

4.8.2. Cumulative Water Use

Cumulative water use values experienced by various crops under mulch and no mulch treatments have been depicted in Fig.17 and also in Table 4.13.

Table 4.13. Treatment effects on seasonal water use and daily water use

Treatments	Seasonal water use (cm)	Daily water use (mm)
	<u>Mulch</u>	
Wheat	43.10	2.43
Barley	37.25	2.42
Linseed	37.82	2.27
Mustard	33.94	2.42
Lentil	38.70	2.41
	<u>No mulch</u>	
Wheat	44.93(4.24)	2.65(9.05)
Barley	39.23(5.31)	2.63(8.67)
Linseed	39.93(5.57)	2.51(10.57)
Mustard	35.25(3.85)	2.57(6.19)
Lentil	39.82(2.89)	2.55(5.88)

Figures in parenthesis indicate per cent increase of water use over mulched treatment.

Among various crops highest value of cumulative water use was recorded by wheat (43.10cm) followed by lentil, linseed, barley and mustard, respectively and this was true for both under mulched and unmulched conditions. Under

FIG.(OUT)SIDE LEFT=% TOTAL MOISTURE CONTRIBUTION AT VARIOUS DEPT
 FRONT SIDE = DEPTHWISE CUMULATIVE WATE USE (CM)
 WITHIN BAR=TOTAL WATER UTILISED BY A CROP (CM)
 SOIL DEPTH= FROM TOP TO BOTTOM

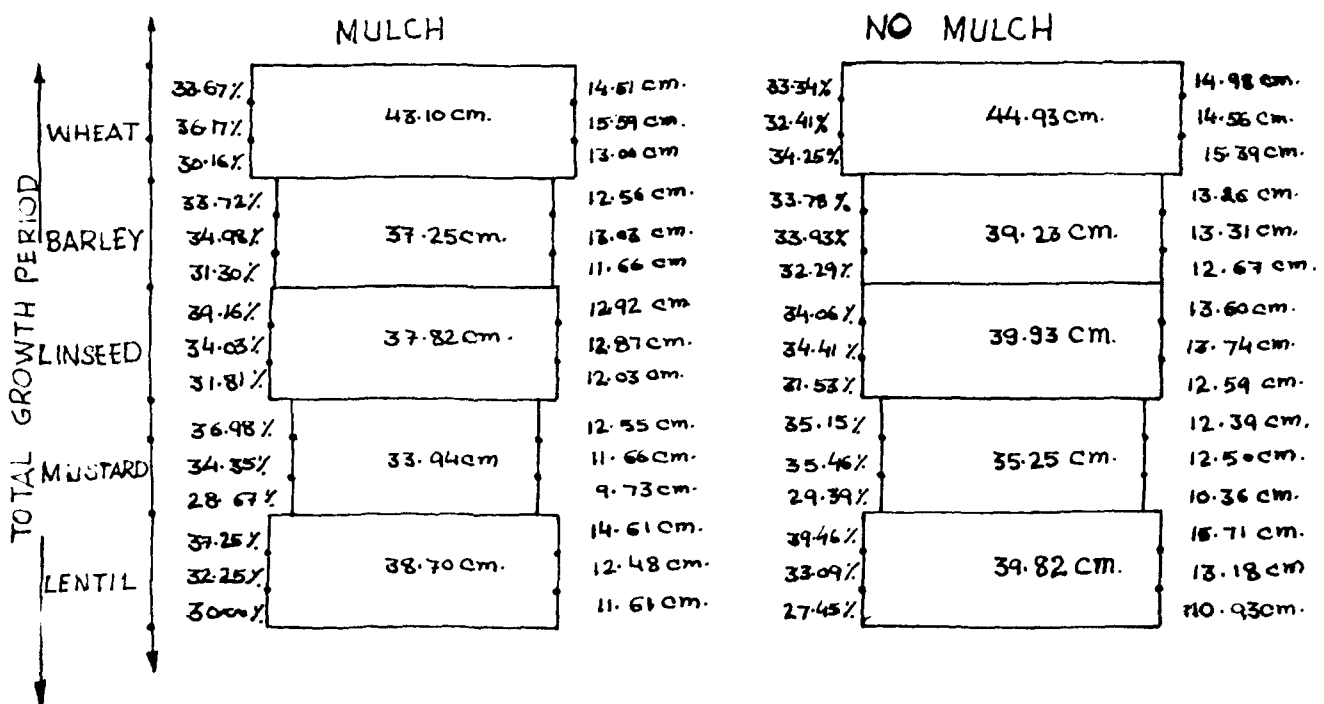

FIG. 17 DEPTHWISE CUMULATIVE WATER USE (CM) AT GROWTH OF RABI CROPS

mulched treatment for wheat and barley highest contribution for cumulative water use was noticed from 20-40 cm layer whereas for rest of the crops upper layers exhibited this phenomenon. Lower layers of soil so studied in these investigations, always recorded least values of cumulative water use for wheat (13.00 cm), barley (11.66 cm), linseed (12.03 cm), mustard (9.73 cm) as well as lentil (11.61 cm).

However, under no mulch conditions trend was somewhat different. Upper layers (0-20cm) recorded highest values for wheat and lentil, whereas for other crops middle layers noticed highest values. Lowest layers 40-60 cm always resulted in lesser values of cumulative water use for all the crops except wheat.

4.8.3. Daily water use

In general, daily water use values under no mulch conditions remained higher than mulched conditions for all the crops studied (Table 4.13). Per cent increase of water from mulched plots over no mulched ones in wheat, barley, linseed, mustard and lentil, respectively were 9.05, 8.67, 10.57, 6.19 and 5.88.

Among various crops wheat noticed highest daily water use of the amount of 2.43 mm, followed by barley and mustard (each 2.42 mm), lentil (2.41 mm) and linseed (2.27 mm) under mulched conditions. The trend was quite the same for no mulched treatments also except for the fact that here barley experienced higher water use than mustard by about 0.14 mm daily.

4.8.4. Economics of water use

A cursory examination of data Table 4.14 an interesting observation appeared that the highest net return to the tune of Rs.4419.43 per hectare given by the linseed crop when raised under mulched condition. The second highest order of net income was shown by lentil, worth Rs.3947.40 per hectare and then

closely followed by wheat and barley. Whereas the lowest net income brought out by mustard under mulched treatment. The similar trends were revealed by all these crops under no mulched conditions also, although there were considerable depressions in monetary net returns when these crops were grown without mulching material.

Table 4.14. Treatment effects on monetary returns/ha mm water used

Treatments	Net returns (Rs/ha)	Total water expense(mm)	Net return/ha mm of water use
<u>Mulch</u>			
Wheat	3045.58	431	7.06
Barley	1720.21	372	4.62
Linseed	4419.43	378	11.69
Mustard	1482.84	339	4.37
Lentil	3947.40	387	10.20
<u>No mulch</u>			
Wheat	2132.63	449	4.74
Barley	1136.51	392	2.90
Linseed	3169.43	399	7.94
Mustard	1015.84	352	2.88
Lentil	2963.60	398	7.44

Further, looking to data Table 4.14 for total water expense revealed that the maximum water expense with mulch application showed by wheat crop to the level of 431 mm during its cropping life span, where as other crops showed water expense ranging in between 339 to 387 mm. Again wheat has shown the highest order of water expense to the tune of 449 mm while growing without mulch

and other crops came in the order of linseed 399 mm, lentil 398mm, barley 392 mm and mustard 352 mm showed the lowest.

From the Table 4.14 it can be seen that the highest net returns (Rs. 11.6) against each mm of water use showed by linseed crop, under mulch application. Which was closely followed by lentil. On the other hand the lowest net returns for each mm water use were recorded under mustard and barley, and wheat remained intermediate. The overall performance of all crops grown without mulch gave lesser net returns against per mm of water use in comparison to mulched conditions. Still the order of crops was the same as that of mulched plots. The highest order remained with linseed and lowest order was in case of mustard and other crops were intermediate in respect of net monetary returns per hectare mm of water use.

4.9. Soil Chemical Properties

4.9.1. Available N : Mulching with lantana litter resulted in significant increase in terms of available N in soil for each crop studied (Table 4.15 and Appendix XIII). Among various crops, in fact lantana litter mulch brought about 11.39, 11.42, 14.43, 9.37 and 13.23 per cent increase in available N content of soil over control for wheat, barley, lentil, linseed and mustard crop, respectively. Under mulched conditions, plots sown with wheat accumulated largest quantity of N which was significantly more than that of linseed which in turn was followed by lentil plots. Mulched lentil and barley sown plots were statistically at par with each other so far as the available N content in soil was concerned. Least available N was recorded from mustard plots. Similar trend was revealed by no mulch treatments.

4.9.2. Available P : Mulching treatments did not differ significantly in affecting the Available P content of soil (Table 4.15). However, the differences among crops were significant in mulched plots. The highest quantity was from barley sown plots which were at par with wheat, mustard and lentil sown plots but significantly more than that of linseed sown plots. The available P content of soil in wheat, barley, mustard, lentil and linseed plots were 13.75, 26.00, 25.50, 14.37 and 12.27 kg/ha, respectively.

Table 4.15. Mean treatment effects on available N, P and K at harvest (kg/ha) in soil

Treatments	Available N		Available P		Available K	
	No mulch	Mulch	No mulch	Mulch	No mulch	Mulch
Wheat	561.25	628.00(11.89)	19.37	23.75(22.58)	311.75	341.00(9.38)
Barley	505.25	563.00(11.42)	18.75	26.00(38.66)	289.50	340.25(17.53)
Linseed	511.00	585.75(14.48)	17.25	19.87(15.22)	275.75	345.75(25.38)
Mustard	488.00	533.50(9.32)	21.12	25.50(20.71)	251.75	309.25(22.84)
Lentil	500.75	567.00(13.23)	20.25	24.37(20.37)	302.75	330.75(9.24)
$S_{DM} \pm$ for mulch	8.96		1.96		14.72	
CD5% for mulch	15.27		3.35		25.08	
$S_{DM} \pm$ for crops	14.18		3.11		23.28	
CD5% for crops	24.15		NS		39.65	

Figures in parenthesis indicate per cent increase of N, P and K content over no mulch treatments.

Interaction effects between mulch and crops on available N, P and K is non-significant.

However, under no mulch treatments highest quantity of P was recorded from mustard sown crops which remaining at par with barley, wheat and lentil recorded significantly more amount of P than that of linseed plots. The per cent increase of available P was highest (38.66%) in barley and lowest in linseed (15.22%) under mulched plot over the control.

4.9.3. Available K

Mulching and no mulch treatments did not differ significantly in influencing the available K content of soil after harvest as shown in Table 4.15 and Appendix XI'.

Under mulched conditions, linseed crop recorded highest quantity of available P (345.75 kg/ha). This was at par with all other crops except mustard crop which resulted in significantly lesser amount of available K (309.25 kg/ha).

Same way under no mulch treatment, mustard plots recorded minimum amount of available K and highest quantity was that from wheat plots. The per cent increase of available K in soil under mulched plot over control due to lantana mulch in wheat, barley, linseed, mustard and lentil crop was 9.38, 17.53, 25.38, 22.84 and 9.24, respectively.

4.10. Water Use Efficiency

Values of water use efficiency experienced by various crops under mulched and no mulched treatments with respect to grain, straw and biological yield have been given in Table 4.16.

A perusal of the data reveals that mulching always resulted in higher water use efficiency for all the crops with respect to grain, straw as well as biological yield. The per cent increase in water use efficiency was highest in barley (42.86) and lowest in lentil (35.20) under mulch treatments over no mulch treatments.

Increase in water use efficiency with respect to grain from mulched effects over unmulched plots were 37.06, 42.86, 41.14, 39.42 and 35.20 per cent for wheat, barley, linseed, mustard and lentil crops, respectively and corresponding increments for straw yield were 41.13, 46.34, 52.29, 58.30 and

Table 4.16. Mean treatment effects on water use efficiency of Rabi crops
(kg/ha/cm)

Treatments	Grain	Straw	Biological
		<u>Mulch</u>	
Wheat	58.43(37.06)	92.64(41.13)	151.07(39.53)
Barley	50.46(42.86)	75.97(46.34)	126.43(44.93)
Linseed	36.84(41.14)	99.37(52.29)	136.21(49.10)
Mustard	17.61(39.42)	67.96(58.30)	85.57(54.01)
Lentil	35.87(35.20)	78.92(46.44)	114.79(42.73)
		<u>No mulch</u>	
Wheat	42.63	65.64	108.27
Barley	35.32	51.91	87.23
Linseed	26.10	65.25	91.35
Mustard	12.63	42.93	55.86
Lentil	26.53	53.89	80.42

Figures in parenthesis indicate the per cent increase over no mulch treatments.

46.44 per cent, respectively. Taking into account the biological yield highest increase was recorded in case of mustard crop (54.01%) and the least from wheat (39.53%). Per cent increase in barley, linseed and lentill were 44.93, 49.10 and 42.73 per cent, respectively.

4.11. Economics

Data in respect of gross returns, net returns and net returns per rupee invested as influenced by the various treatments have been presented in

Table 4.17. and cost of cultivation has been given in Appendix XV, XVI, XVII, XVIII and XIX.

It is apparent from the Table 4.17 that in all the crops gross returns as well as net returns from mulched plots were markedly greater than those from no mulch treatments. Highest net returns were obtained from linseed crop (Rs.4419.43) and least from mustard crop (Rs.1482.84), other crops have shown of intermediary type of net returns.

Table 4.17. Treatment effects on gross returns, net returns and cost benefit ratio (Rs/ha)

Treatments	Gross returns (Rs/ha)	Net returns (Rs/ha)	Net return per rupee invested(Rs)
		<u>Mulch</u>	
Wheat	5751.70	3045.58	1.12
Barley	4044.45	1720.21	0.74
Linseed	6699.00	4419.43	1.93
Mustard	3556.00	1482.84	0.71
Lentil	5982.20	3947.40	1.94
		<u>No mulch</u>	
Wheat	4338.75	2132.63	0.96
Barley	2960.75	1136.51	0.62
Linseed	4949.00	3169.43	1.78
Mustard	2589.00	1015.84	0.64
Lentil	4497.40	2963.60	1.91

Consequently mulching helped in having higher net returns per rupee invested in each crop studied. Under mulched conditions highest net returns per rupee invested were obtained from lentil and linseed Rs.1.94 and least from mustard Rs.0.71, whereas under no mulch treatments, highest net returns per rupee invested were obtained from lentil crop (Rs.1.91) and least from barley (Rs.0.62). Thereby these results very much speak of favourable effects of mulching in terms of economics too, particularly in states like Himachal Pradesh where family labour can be effectively employed for cutting the lantana litter to be applied in rabi crops and to have increased benefits

DISCUSSION

Chapter 5

DISCUSSION:

The experimental findings of the present investigation entitled "Effect of lantana mulch on water use efficiency, growth and yield of rainfed rabi crops" have been discussed in the current chapter and an effort has been made to establish the cause and effect of relationships in the light of available evidences.

Growth and yield of various crops are the net resultant product of the interactions of their physico-chemical environment of soil and plant and also agro-climatic factors plus the genetic make up. The yield of rabi crops, thus, may evidently be increased, unaffected or decreased by a given alteration in their micro and macro-environment.

The meteorological data during cropping season (Fig. 1 and Appendix I) revealed that various agroclimatic parameters were nearer to optimum level for growth and development of rabi crops excepting that the rainfall (40.84 cm) was little lower than the normal winter rains of the area. The mean atmospheric temperature varied from 3.4°C in January to 28.8°C in April. The low winter temperatures during January and February months inhibit growth for some duration and hence prolong the days required to maturity of crops. Under mulched conditions a little higher soil temperatures of upper soil profiles remained beneficial for better root growth, but generally no difference was recorded in temperature variations due to mulching from the deeper soil profiles. Contrary to this during warm months of the year i.e. April and March (Appendix I) the mulching material helped in maintaining lower soil temperatures of upper soil profile. These findings very much speak of the role of mulch materials

in moderating the soil temperature thereby affecting crop growth and development favourably.

Observations with respect to various growth and yield attributes i.e. germination count, number of tillers or branches per plant (Table 4.1), plant height (Table 4.2), number of branches or tillers per plant, number of effective tillers or branches per plant, number of grains per ear or pod, 1000-grain weight (Table 4.4) revealed that mulching with lantana litter brought out significant differences in respect of number of effective tillers or branches per pod and 1000-grains whereas other characteristics remained non-significant. No doubt that mulch materials are usually used for soil and water conservation and erosion control but they do influence growth and yield attributes through their effect on soil temperature, weed competition, disease and pest infestation, in some cases availability of mineral nutrients and organic matter content of the soil besides affecting the pace of microbial activity. Ultimately the effect is on the crop yield.

The beneficial effects observed due to mulching in case of effective tillers or branches and 1000-grain weight might be the result of such functions of mulch materials. Consequently significant gains in grain and straw yields of various crops so tried in the present investigation were obtained due to an application of Lantana camara mulch. The percentage increase in grain yields due to mulching were 31.48, 35.66, 33.68, 34.15 and 31.43 for wheat, barley, linseed, mustard and lentil, respectively, whereas the corresponding increments for straw yield were 35.40, 38.99, 44.26, 52.41 and 42.31 per cent, respectively. These results resemble to findings of Kanivets and Fomin (1977), Krishna and Pandey (1981), Balyan and Malik (1981), Ghosh (1984), Sharma et al. (1981).

Bhan (1978) and Roy *et al.* (1976) and many other workers reported similar results having the positive effect of mulch on grain and straw yield of different rainfed rabi crops.

As shown in Fig.6, 7, 8, 9 and 10 the seasonal water use under all the treatments showed a sigmoid pattern which has been discussed under the different crops.

Wheat

As shown in Fig.6, the seasonal water use under mulched and non-mulched treatments ranged from 3.26 to 10.86 cm and 2.98 to 10.57 cm, respectively recorded from 30 to 120 DAS. Upto 30 DAS the moisture depletion was maximum from the upper most layers of soil in both mulched and unmulched treatments which is 49.6 and 48.4 per cent of the total water expense. Also at 60 DAS, the similar trend in both the treatments was observed, however at 90 DAS, trend was different. At 90 DAS, the moisture extraction in case of mulched wheat was recorded slightly higher (2.97 cm) from the lower depth (20-40 cm). However, in case of unmulched wheat, higher extraction of moisture (3.15 cm) was found from the lower depth (40-60 cm). Similar trend of moisture depletion in mulched and unmulched treatments was recorded at 120 DAS. The moisture depletion at 150 DAS and at harvest stages was found comparatively higher from the lowest depth in both the mulched and nonmulched plots viz., 3.89, 2.74, 3.95 and 2.86 cm, respectively. This might have occurred due to shallower roots, lesser vegetative surfaces and high evaporation but low ET losses at early stages of crop growth, whereas, the deeper root growth and more vegetative surface at later stages extracted more soil moisture from upper as well as from

two lower profiles, respectively. The higher soil moisture use from the lowest soil profile is due to high moisture availability in that layer and low water availability in upper profiles besides deep rooting systems.

Under mulched treatments, lesser total water expense (43.10 cm) was observed in comparison to nonmulched treatments (44.93). However, per cent total moisture depletion under mulched and unmulched conditions at depths 0-20 cm, 20-40 cm, 40-60 cm was recorded 33.67, 36.17, 30.16, 33.34, 32.41, 34.25, respectively. These findings are in line with the findings of Hazra et al. (1973) and Prakash et al. (1979). Chakor (1975); Sharma (1984) who have also obtained the similar results in respect of moisture depletion studies for all these crops.

Barley

As represented in Fig.7 and 13, the pattern of moisture depletion somewhat different from that of wheat was observed. In all the depths at 30 DAS, the water extraction was higher in unmulched plots than mulched plots viz., 2.76, 3.93 cms, respectively. Conversely to this at 60 DAS different trend viz., 5.35, 5.18 cm was observed. However, at both the stages, the water depletion under mulched and unmulched treatments was recorded higher in upper layers and comparatively less in lower layers. At 90 DAS total profile seasonal water use was comparatively higher in unmulched plots (8.30 cm) than that of mulched plots (7.84 cm) which was 21.16 and 20.76 per cent of the total water expense, respectively. As far as moisture depletion is concerned, it was higher in lower layers than upper ones which ranged from 2.98 to 2.63 cm in mulched and 3.15 to 2.39 in unmulched plots. Seasonal water use at 150 DAS and harvest stages was

observed comparatively higher in unmulched plots than that of mulched plots viz., 8.21, 8.73, 4.84 and 5.02, respectively. The total water depletion during the entire cropping season was found higher in unmulched treatments viz., 39.23 and 37.25 cm. The total water expense was recorded higher under both the treatments in the lower layer (20-40 cm) viz., 13.03 and 13.31 cms, respectively. The total water extraction in soil profile from 0-20 and 40-60 cms was recorded 12.56, 11.56, 13.25 and 12.67 cms under mulched and non-mulched treatments, respectively. These trends were in conformity of the results of Chakor (1975) who have also observed similar moisture depletion in case of barley.

These findings clearly indicated that this might have occurred due to limited vegetative, root development and lower environmental demand for transportation at early stages. However, at harvest stage, it might be due to lesser demand of crops for water and nutrients. These findings are in conformation with the findings of Ali and Prasad (1975), Lal (1972), Muhammad et al. (1965).

Linseed

As diagrammatically shown in Fig.8 and 14 in all the depths unmulched treatments recorded higher water use than mulched treatments at 30 and 60 DAS. Contrary to this, quantum of water utilized by the crop was recorded highest at 90 DAS under mulched plots and 120 DAS under unmulched plots, viz., 8.24 and 8.22 cms, respectively. After 120 DAS, the per cent moisture contribution declined substantially unto harvest stage for which the lowest values were 13.85, 15.43 under mulched and unmulched plots, respectively. The total water depletion during crop growth season

under both the mulched and unmulched treatments was recorded 37.82 and 39.93 cms, respectively. The per cent total moisture contribution was higher from the upper layer (0-20 cm) under mulched conditions and comparatively lesser from the lower layers. However, the higher moisture depletion percentage in 20-40 cm was recorded under unmulched conditions of soil profile (0-60 cm) viz., 34.41 cm. Reason for the same has been described earlier. These findings are in conformity with those of Withana *et al.* (1971) and Hedge (1964).

Mustard

As shown in Fig.9, and 14 at 30 and 60 DAS, the water depletion under unmulched plots was higher than mulched plots in all the three depths under study. At 90 DAS, reverse trend was obtained. The highest per cent water contribution was obtained at 90 DAS under both the mulched and unmulched treatments viz., 34.54 and 31.36, respectively. Almost at all the stages except harvest, higher contribution from shallow soil layers under mulched plots was recorded. At harvest stage, the moisture contribution percentage was higher from lower layers than upper ones in both the treatments under study.

Total water expense recorded was 33.94 cm and 35.25 cm under mulched and unmulched conditions. These findings are in line with those of Lehene (1962) and Fains and Singh (1971) and Lal (1974).

Lentil

As presented in Fig.10 and 16 at 30 and 60 DAS more amount of water was consumed by unmulched plots than the mulched plots. However, at 90 and 120 DAS trend was different. Similar trend of equal water used was

obtained at 150 DAS and harvest stage. The highest depletion percentage was recorded at 90 DAS under both mulched and unmulched treatments viz., 39.22 and 36.41, respectively. Depthwise fluctuation in moisture contribution was reflected only by shallow and deeper soil profile. The total water depleted was higher in unmulched plots (39.82 cm) than mulched plots (38.70 cm) during the entire cropping season. These findings are in line with the findings of Bains and Chowdhary (1970). Chakor (1975) also observed the similar trends while working on lentil and other crops under rainfed farming conditions.

Water Use Efficiency

As shown in Table 4.16, data reveals that mulching always resulted in higher water use efficiency for all the crops with respect to grain, straw and biological yield. Increase in water use efficiency with respect to grain from mulched over unmulched plots were 37.06, 42.86, 41.74, 39.42 and 35.20 per cent for wheat, barley, linseed, mustard and lentil crops. These variations in data pertaining to water use efficiency might have occurred due to higher yields or low quantity of water used consumptively. Under mulched treatments besides their different yielding behaviour and water consumption trends.

Also these findings were similar to that of Ali and Frazed (1977) and Kapur et al. (1978). As recorded by them, all mulches except FYM increased water use efficiency and the highest value of 14.8 was obtained with straw mulch which was almost twice to that of control.

Nutritional Status

Mulching with lantana litter resulted in tremendous increase in terms of available N in soil for all the crops after harvest. Among various crops, wheat resulted in the highest accumulation of N and least N

accumulation was recorded in mustard. In terms of P and K in soil, lantana mulch resulted in slight increase over the control. Highest P accumulation was recorded from barley sown plots. However, linseed recorded the highest quantity of K accumulation in the soil. This might have occurred because of more decomposition of lantana twigs with the advancement of crop and increase in microbial activity with the increase in temperature. These findings resembles to those of Weeks et al.(1950), Swenson et al.(1949) and Holmes et al.(1948).

Economics

As shown in Table 4.17 mulched treatments resulted in increased gross as well as net returns over the respective controls. Highest and lowest net returns were contributed by linseed and mustard crops, respectively. These findings were not in conformity to those of Bains et al.(1971) and Rajbans et al.(1967) for no other reason but poor adaptability of mustard to the prevailing environmental conditions during early establishment in comparison to linseed, which is confirmed by Singh (1972) and Asthana et al. (1971)

SUMMARY

Chapter 6

SUMMARY AND CONCLUSION

The field investigations entitled "Effect of lantana mulch on water use efficiency, growth and yield of rainfed rabi crops" was conducted at Watershed Management Area, Agricultural Research Farm, Himachal Pradesh Krishi Vishva Vidyalaya, Palampur during Rabi 1985-86. The main objectives of these studies were:

1. To observe the effect of lantana mulch on the growth and yield of rabi crops,
2. To compare the water use efficiency values of various rabi crops with and without mulch.
3. To study the moisture depletion pattern by different rabi crops in the presence and absence of lantana mulch.
4. To determine the changes in soil properties under mulch and no mulch conditions.
5. To calculate the economics of the crops.

The experiment was laid out in randomized block design replicated four times. The treatments comprised five crops, i.e. wheat, barley, linseed, mustard and lentil each with two levels of mulching i.e. 10 t/ha and no mulch as control. Treatmentwise half dose of nitrogen alongwith full doses of potash and phosphorus were applied at the time of sowing of all the crops except lentil in which the full dose of all the nutrients was applied. Remaining half dose of nitrogen was topdressed at 3-4 weeks of sowing. Lantana litter mulch (freshly cut upper most 30 cm shoots of Lantana camara) were first chaffed by chaffcutter and then surface spread on the day of sowing itself @ 10 t/ha.

An application of Lantana litter mulch @ 10 t/ha brought out significant gains in number of effective tillers or branches per plant, 1000-grain weight and consequently the grain and straw yields of all the crops.

In fact as a result of this increased plant growth and vigour, the percentage in grain yields due to mulching were 31.48, 35.66, 35.68, 34.45 and 31.43 for wheat, barley, mustard, lentil and linseed, respectively whereas the corresponding increments recorded in straw yields were 35.40, 38.99, 44.26, 52.41 and 42.31 per cent, respectively.

The seasonal water use under all the treatments revealed a sigmoid pattern. In general, it was found that from 30 days after sowing upto 120 days after sowing, the periodical moisture use increased and then slightly decreased towards harvest. The findings revealed that water expense in mulched treatments was markedly less than that in unmulched counterparts attributing to increased water holding capacity of soil with mulch application. Among various crops highest value of total water expense was recorded from wheat crop and minimum for mustard both under mulched and unmulched condition. Mulching also recorded significant gains in water use efficiency values in each crop studied in the present investigation.

Besides, mulching with lantana favourably affected the nutrient status of soil with respect to available nitrogen, phosphorus and potash.

Consequent upon all these effects, mulched treatments, resulted in increased gross and net returns and net return per rupee invested over the no mulch treatments. Highest net returns worth Rs.4419.43 was recorded in linseed and least from mustard (Rs.1482.84) under mulched conditions, whereas under no mulch conditions highest net returns (Rs.3769.43) were obtained from linseed crop and least again from mustard (Rs.1015.84).

As far as monetary net returns/ha mm of water used were concerned the top ranking to the tune of Rs.11.69 were contributed by linseed crop with mulched treatment as against lowest from barley (Rs.4.62). The level of net returns/ha mm of water used reduced to Rs.794 for highest contributing crop linseed and Rs.2.89 for barley under no mulch conditions.

CONCLUSION

From these investigations, it can be safely concluded that freshly cut uppermost green twigs of Lantana camara if applied to rainfed rabi crops viz., wheat, barley, linseed, lentil and mustard @ 10 t/ha. the practice can effectively conserve the soil moisture, economically and beneficially promote the growth as well as improve the net returns under rainfed conditions of Himachal Pradesh. Where, lantana bush is available in abundant quantity from waste land areas of hills. The mulching material can be collected economically by employing the family members locally. Hence an application of lantana may be recommended for farmers for mulching material.

REFERENCES

REFERENCES

- Acharya, C.L. and Bhagat, R.M. 1984. Infiltration behaviour, root development and yield of rainfed mays (*Zea mays* L.) under different soil management practices. Proc. Indian Natl. Sci. Acad. Part B, 50: 441-448.
- Acharya, C.L. and Prihar, S.J. 1969. Vapour losses through soil mulch at different wind velocities. Agron. J. 61: 666-668.
- Acharya, C.L., Sandhu, S.S. and Abrol, I.P. 1979. Effect of exchangeable sodium on the rate and pattern of water uptake by Kaya in field. Agron. J. 71: 936-941.
- Allen, John E. 1962. Effect of soil temperature on grain sorghum growth and yield. Agron. J. 54: 257-261.
- Arora, S.A. and Rajat De. 1977. Effect of application of nitrogen, potassium and antitranspirants on the growth and yield of barley under different conditions. Indian J. agric. Sci. 47(4): 191-194.
- Albrecht, W.A. 1976. Nitrate accumulation in soil as influenced by tillage and straw mulch. J. Amer. Soc. Agron. 18: 541-553.
- Ali, Masood and Prasad, Rajendra, 1975. Soil moisture studies in fallow under crop rotation under mulches, antitranspirant and type of insecticide. Indian Soc. Soil Sci. 23(2): 163.
- Allmaras, R.R. and Nelson, W.W. 1971. Corn root configuration as influenced by inter-row variants of tillage and straw mulch managements. Soil Sci. Soc. Am. Proc. 35: 974-980.
- Allmaras, R.R., Voov Rees, W.B. and Nelson, W.W. 1975. Soybean and corn rooting in south western Minnesota. I. Water uptake sinks. Soil Sci. Soc. Am. Proc. 39: 764-771.
- Anderson, D.P. and Kussel, C.C. 1974. Effect of various quantities of straw mulch on the growth and yield of spring and winter wheat. Can. J. Soil Sci. 44: 109-118.
- Anonymous, 1983. Statistical Outline of H.P., Directorate of Economics and Statistics, H.P., Shimla.
- Anonymous, 1984. Statistical Outline of H.P., Directorate of Economics and Statistics, H.P., Shimla.
- Anonymous, 1984. Fertilizer Statistics 1983-84, F.A.I., New Delhi.
- Arora, R.F. 1971. Soil moisture in irrigated and dryland farming. Ind. Eng. 21(9): 29-30.

- Arya, L.M.; Black, G.R. and Farrell, D.A. 1975. A field study of soil water depletion pattern in presence of growing soybean roots II. Plant growth, soil water presence and water loss pattern. Soil Sci. Soc. Am. Proc. 39: 437-444.
- Asthana, K.S. and Singh, U.K., 1971. Linseed variety type 397 of UP does well in Bihar. Ind. Farmy :21(5): 27.
- Bains, S.S. and Choudhary, S.L. 1970. Manuring crops for profit in rainfed areas. Ind. Farmy. 20(4): 21-23.
- Bains, S.S.; Prasad, R. and Bhatia, P.C. 1971. Use of indigenous materials to enhance the efficiency of fertilizer nitrogen for rice. Fert. News. 16(3): 30-32.
- Bains, S.S. and Singh, R.P. 1971. Nothing succeeds sarson on dry lands. Ind. Farmy. 21(5): 5-6.
- Boyer, C.E. 1943. Further results on the effect of different mulching and fertilizer treatments upon the potassium content of apple leaves. Proc. Amer. Soc. Hort. Sci. 44: 57-65.
- Balyan, R.S. and Malik, B.S. 1981. Influence of irrigation and straw mulch on yield, quality and water use efficiency of summer mung. Indian J. Agron. 26(3): 257-261.
- Bansal, G.L. 1983. Effect of various organic wastes on the germination and seedlings growth of wheat and associated weeds. 10th Annual Progress Report 1982-83, Dept. of Agron. & Agronet. H.P.K.V.V., Palampur.
- Bansal, J.P.; Gujral, P.R. and Prihar, S.S. 1971. Effect of mulches on water conservation, soil temperature and growth of maize and pearl millet. Ind. J. agric. Sci. 41(5): 467-473.
- Baver, L.D. 1940. Soil Physics. Chapman and Hall, London: 193-248.
- Bhan, S. 1976. Root development and moisture use of rainfed brown sarson as influenced by Agronomic practices. Indian J. Agron. 21(3): 245-248.
- Winkowski, F.S. 1961. A rapid method for calculating soil moisture content from gravimetric samples. Agron. J. 53(2): 134.
- Black, A.L. 1970. Soil water and soil temperature influences on dry land winter wheat. Agron. J. 62(6): 797-801.
- Black, A.L. 1972. Crop residue, soil water and soil fertility related to spring wheat production and quality after fallow. Soil Sci. Soc. Amer. Proc. 37: 754-758.
- Bodman, C.B. 1942. Nomogram for rapid calculation of soil density, water content and total porosity relationships. J. Am. Soc. Agron. 34: 883-893.

- Hollwer, C.A. and Stephenson, R.E. 1946. Some effects of mulches on soil properties. *Proc. Amer. Soc. Hort. Sci.* 48: 37-39.
- Brengle, K.G. and Whitefield, C.D. 1969. Effect of soil temperature on the growth of spring wheat with and without wheat straw mulch. *Agron. J.* 61: 377-379.
- Broadbent, F.E. and Nakashima, T. 1970. Nitrogen immobilization in flooded soils. *Soil Sci. Soc. Amer. Proc.* 34: 218-222.
- Chakor, I.S. 1975. Water use and water depletion pattern by dryland pure and mixed cropped wheat under nitrogen utilization. Ph.D Thesis, Meerut University.
- Chandani, J.J., Raheja, P.C. and Singh, P. 1960. Studies on crop rotation. II. Relative economics of different rotations. *Indian J. Agron.* 5(4): 273-282.
- Chaudhary, P.C. and Chatterjee, B.N. 1967. Moisture conservation under mulches in eroded terraced soil of Ranchi. *J. Soil and Water Conservation of India.* 15: 61-67.
- Chaudhry, M.R. and Prihar, S.S. 1974. Root development and growth response of corn following mulching cultivation. *Agron. J.* 66: 350-355.
- Coleman, E.A. 1944. The dependence of field capacity upon the depth of wetting of field. *Soil Sci.* 58: 43-55.
- Doboszynska, H. 1970. The effect of spring and autumn water deficiency on the development and structure of winter rape yield. *Rozniki nauk. Rolniczych. A.* 90(4): 73-94.
- Fisher, R.A. and Yates, F. 1963. Statistical tables for biological agriculture and medical research. Publication by Oliver and Boyd Ltd. Edinburg (1963).
- Gardner, W.K. and Gardner, W.K. 1969. Relation of water application to evaporation and storage of soil water. *Soil Sci. Soc. Am. Proc.* 33: 192-196.
- Gardner, W.K. 1964. Relation of root distribution to water uptake and availability. *Agron. J.* 56: 41-45.
- Gautam, R.K. 1968. Irrigation studies with tall and dwarf varieties of wheat. *Proc. Symp. Water Management. Udaipur. Ind. Soc. Agron.* 1070-1090.
- Gautam, R.C. and Singh, R.K. 1970. Effect of rotations on the yield of fodder and grain crops. *Indian J. Agron.* 15: 177-182.
- Chiloyal, B.P. and Satya Hand, 1978. Influence of soil compaction on shoot and root growth of rice. *Indian J. Agron.* 14: 107-112.
- Childyal, B.P. and Tripathi, R.P. 1979. Studies on thermal regime of tarai soil and their relation to crop growth (c.f. *Field Crop Abstr.* 7331: 767).
- Grosh, S., Das, D.K. and Deb, A.R. 1984. Effect of inter-row mulching on yield and water use efficiency of pulses under rainfed conditions. *Trans. Indian Soc. Desert Tech.* 8(1): 46-52.

- Greb, B.W. 1967. Per cent soil cover by six vegetative mulches. *Agron.* 59(6): 610-11.
- Greb, B.W.; Smika, D.E. and Elack, A.L. 1970. Water conservation with stubble mulch fallow. *J. Soil Sci. & Water Conservation.* 5(2): 53-62.
- Gregory, P.J. and McGown. 1975. Water relation in winter wheat. *J. Agril. Sci. Camb. L.R. Horton, N.S.* 91: 103-116.
- Gupta, J.P. and Gupta, G.N. 1983. Effect of grass mulching on growth and yields of legumes. *Agr. Water management* 6(4): 335-334. CAZMI, Jaipur.
- Han, S.K. and Han, W.D. 1970. Research on the effect of soil and water conservation by straw mulch on sloping fields. *Research Report of the Office of Rural Dev. S. Korea.* 13: 1-12.
- Hanks, R.J. 1958. Water vapour transfer in dry soil. *Soil Sci. Soc. Am. Proc.* 22: 372-374.
- Hazra, C.R.; Ray, S.S. and Biswas, T.D. 1973. Effect of stored moisture retention through conservation practices and supplemental irrigation on wheat yield under dry land farming conditions. *J. Indian Soc. Soil Sci.* 21(1): 9-22.
- Heady, H.O. 1957. Economics of cropping system soils. *The 1951 year Book of Agri. USDA* pp. 426-433.
- Hedge, B.R. 1964. Studies on the associated growth of barley with cereals, legumes and oilseed crops and the response of pure and mixed stand to feet larani condition. Thesis for M.Sc. degree, P.B. School, IARI, New Delhi.
- Hirose, S. 1973. Mineralization of organic nitrogen of various plant residues in the soil under upland conditions. *J. Sci. Soil Manure Japan.* 44: 157-163.
- Holmes, J.W. and Greacen, E.L. 1960. The evaporation of water from bare soil with different tith. *Trans. 7th Intern. Cong. Soil Sci.* 1: 11-13.
- Holmes, D.S.; Tyson-Smith C. Lockman. 1948. Effect of different mulches upon the nutritive value of tomatoes. *Soil Sci.* 65: 471-475.
- Jack, G.V. & Brind, V.D. and Smith, R. 1955. Mulching commonwealth Soil Sci. Tech. Communication No. 49: 37p.
- Jackson, M.L. 1967. Soil chemical analysis, Oxford IBS, Bombay.
- Jaggi, I.K.; Gupta, R.K. and Russel, M.B. 1977. Field water balance in a vertisol in a fallow and cropped condition. *Ind. J. agric. Sci.* 47: 617-621.
- Jain, S.C. 1967. Agricultural planning in India. Kitab Mahal. Allahabad 364 p.

- Jain, P.M., Saraf, C.S. and Pandey, S.L. 1983. Effect of moisture conservation practices and fertilizer application on yield and economics of rainfed crops. *Indian J. Agron.* 28(3): 225-228.
- Joon, R.K.; Oswal, M.L. and Hooda, I.S. 1984. Mustard germination as influenced by soil moisture and soil cover over the seeds. *Indian J. Agron.* 29(3): 392-393.
- Khan, A.P. 1983. Influence of mulching on bulk density and aeration porosity of soils in relation to ground nut production. *Archiv für Acker- und Pflanzenbau und Bodenkunde* 27(7): 439-444.
- Khan, N.A. 1984. Complementary use of organic wastes in wetland transplanted rice and their residual effect on wheat. Ph.D Thesis, H.P.K.V.V. Palampur.
- Kanivets, I.T., and Fomin, V.A. 1977. The use of straw in agriculture of the arid and steppe zone of northern Kazakhstan. *Izvestiya Akademii Nauk, S.S.S.R. Biologicheskaya*. No. 4: 534-540.
- Kanoa, T.; Hirano, J. and Egnudi, H. 1974. The prevention of lodging of wheat and barley by application of chlome soil mulching and other treatments. *Bulletin of the Chugaku National Agri. Experiment Station A.No.23*: 1-26 (c.f. *Field Crop Abstr.* 28: 649).
- Kanwar, J.S. 1985. Dry farming. *Bull. Special Bulletin issued to Press conference.* ICRISAT, Sept. 1985.
- Kapur, O.C.; Aggarwal, G.C., Kanwar, B.S. and Tripathi, B.R. 1978. Effect of mulching with pine needles on the yield of timely and late sown wheat. *Indian J. agric. Sci.* 48(10): 605-609.
- Kilmer, V.J. and Alexander, L.T. 1949. Method of making mechanical analysis of soil. *Soil Sci.* 68: 15-24.
- King, F.H. 1907. *Text Book of Physics of Madison, Wisconsin* pp. 161-203.
- Krishnamoorthy, C.L. 1971. Review of dry land research in A.P. *Ind. Eng.* 21(2): 9-14.
- Krishna and Pandey, S.L. 1984. Response of lentil to mulching and kaolin spray under varying soil moisture regimes. *Indian J. Agron.* 29(4): 436-440.
- Lal, R. 1974. Soil temperature, soil moisture and maize yield from mulched and unmulched tropical soil. *Plant and Soil.* 40: 129-143.
- Lal, R. 1975. Role of mulching techniques in tropical soil and water management *IITA Tech. Bull. No. 1*: 8-28.

- Lal, K.B. and Ray, S. 1976. Economics of crop production of different cropping intensities. *Indian J. agric. Sci.* 46:93-96.
- Lehane, J.J. and Staple, W.J. 1962. Effect of soil moisture tension on growth of wheat. *Canad. J. Soil Sci.* 42(4):108-18.
- Lenkove, L. 1969. Reciprocal relationship between barley and wheat in mixed sowing. *C.R. Acad. Sci. Agric. Bulg.* 2(2):99-104.
- Mandal, B.K. and Gosh, T.K. 1984. Effect of mulches on growth and yield of sesame. *Indian J. Agron.* 29:549-552.
- Mandal, B.K. and Vamadevan, V.K. 1975. Effect of mulches on the growth and yield of Rabi crops in the Mahanadi Delta. *Indian J. Agron.* 20:190-192.
- McCalla, T.M. and Dully, F.L. 1946. Effect of crop residues on soil temperature. *J. Amer. Soc. Agron.* 38: 75-89.
- Mehrotra, G.L. and Agnihotri, C.P. 1970. Effect of plant densities and sowing dates on fertilizer response in high yielding wheat. *U.P. Ist Agril. Sci.* 158-162 (c.f. *Field Crop Abstr.* 27: 4839).
- Merwin, H.D. and Peech, M. 1950. Exchangeability of soil potassium in sand, silt, clay fraction as influenced by the nature of complementary exchangeable cations. *Soil Sci. Soc. Am. Proc.* 15: 125-128.
- Minami, M. 1976. Research status of soil fertility of paddy soil and the significance of organic substance application (in Japanese) *Hukumo* 43(1):3-17.
- Mohan, K.C., Mandal, R.C. and Singh, K.D. 1973. Effect of mulching and plant density on growth, yield and quality of Amorphallus. *Indian J. Agron.* 18:62-66.
- Morgan, J.M. 1971. The death of spikelets in wheat due to water deficit. *Aug. of Experimental Agri. Animal Husband.* 11(30):249-351.
- Muhammad, H. Salim. 1965. Root development of wheat, oat and barley under condition of soil moisture. *Agron. J.* 57:593-96.
- Murty, G. Srirama and Rao, K. Umamaheswara. 1969. Effect of mulching on the growth and yield of tobacco crops in relation to soil temperature and moisture. *Indian J. Agric. Sci.* 39: 742-748.
- Mishra, A.K. and Gupta, V.K. 1979. Handbook on analysis of agricultural experiments. IASRI, Library Avenue, New Delhi.
- Nyamah, J.U. and Black, T.A. 1977. Rates and pattern of water uptake in a Daigrass for forest soil. *Soil Sci. Soc. Amer. J.* 41: 972-979.
- Rodriguez, F.D., Oliveira, I.P. and Azevedo, G.W. 1973. Effect of mulching on a bean crop. *Sieva* 33(79):1-7 (c.f. *Field Crop Abstr.* 1973: 932).
- Olson, S.R., Cole, C.V., Watanabe, F.S. and Dean, L.S. 1954. Estimation of available phosphorus in soil with NaHCO_3 . *USDA Circ.* 939:19 and *Soil Fertil.* 17:1890
- Pande, V.G. and Sukhatme, P.V. 1967. Statistical methods for Agricultural workers. 2nd Ed. ICAR, New Delhi.
- Patel, J.C. and Singh, K.K. 1980. Effect of irrigation, mulching and bioregulator on the productivity of sunflower. *Indian J. Agron.* 25:122-128.
- Patil, S.V. and Kulkarni, K.R. 1973. Crop planning for optimum utilization of input resources. *Proc. Symp. Multiple Cropping (Hissar)* pp.93-95.

- Peele, F.C., O.W. Beale and Lesesne, F.F. 1946. Irrigation requirements of south Carolina soils. *Agri. Eng.* 29: 157-158.
- Pena, M.L. 1970. Erosion control on a trumao soil with two levels of straw. *Agri. Technica* (1970) 38(2): 49-53.
- Piper, C.S. 1966. Soil and plant analysis, Hans Publ. Lomax. 200-201 pp.
- Ponnamperuma, F.H. 1972. The chemistry of submerged soil. *Adv. Agron.* 24: 29-96.
- Prihar, S.S.; Ranjodh Singh, Nathu Singh and Sandhu, B.S. 1979. Effect of mulching previous crops or fallow on dryland maize and wheat experiments. *Expt. Agric.* 15: 129-134.
- Prihar, S.S.; Singh, D. and Sandhu, B.S. 1960. Influence of soil and climatic environments on evaporation losses from mulched and unmulched plots. *J. Res. PAU Ludhiana.* 5: 320-328.
- Prihar, S.S., Verma, K.S. and Bajan Singh, 1972. Direct and residual effect of rice husk on crop growth on a sandy loam soil. *Indian J. Agron.* 17(4): 344.
- Rajat, De and Gajendra Giri. 1970. Effect of mulches and Kaolin foliar spray on wheat yield in dry lands. *Indian J. agric. Sci.* 48(6): 334-337.
- Rajbans, K. and Dayal, M. 1967. Growing of legumes and cereals mixture under dry farming conditions. *Indian J. Agron.* 12: 126-31.
- Rajput, K.K. and Singh, N. 1970. Efficiency of different mulches in conserving soil moisture in cotton. *Indian J. Agron.* 15: 41-45.
- RameswORTH, B. 1973. Profitability of fertilizer use for wheat under dry farming condition. *Fert. News.* 16(6): 37-42.
- Rao, Purshotam and Anwar, S.K. 1984. Response of barley (*Lordis vulgare* L.) to soil moisture conservation practices and supplemental irrigation. *Indian J. Agron.* 29(4): 495-500.
- Reddy, R.V. and Pandey, S.L. 1980. Effect of moisture regimes at different growth stages on growth, yield and quality of mustard. *Indian J. Agron.* 25(4): 705-709.
- Reutner, W. 1941. Effect of certain orchard practices on the potassium status of a New York Fruit Soil. *Soil Sci.* 52: 155-165.
- Rice, K.C. 1975. Diurnal and seasonal water uptake and flux within a Bermudagrass. *Soil Sci. Soc. Amer. Proc.* 39: 594-598.

- Richard, L.A. and Weaver, L.R. 1943. Fifteen atmosphere percentage as related to the permanent wilting percentage. *Soil Sci.* 56:33-39.
- Roy, B.K. and Mukherjee, S. 1982. Effect of spraying crude aqueous extract of fruit of Lantana camara L. on wheat plant. *Madras Agric. J.* 69:171-179.
- Koy, K. 1977. Effects of mulches and nitrogen on agronomic performance and moisture use of rainfed wheat. *Thesis Abstr.* 3(4):252-253 (En) Agr. Coll. Ranchi, Bi
- Koy, K., Singh, R.K. and Srivastava, K.N. 1976. Effect of mulches and nitrogen on the performance of rainfed wheat. *Indian J. Agron.* 21:370-374.
- Sadanandan, N. and Mahapatra, I.C. 1972. A study of economics of multiple cropping upland rice area of eastern India. *Indian J. Agron.* 17:112-115.
- Saha, A.K., Chauhan, C.P. and Yadav, D.S. 1980. Studies on soil water behaviour and crop production under rainfed conditions. *J. Indian Soc. Soil Sci.* 28:277.
- Saini, B.C. and Chidyal, B.P. 1978. Seasonal water use by winter wheat grown under shallow water table conditions. *Agril. Water Manag.* 1:263-276.
- Sandhu, K.S. and Gill, G.S. 1973. Critical period of weed competition in maize. *Indian J. Weed Sci.* 5(1):1-15.
- Sazonikov, S. and Moshchenko, Yu. 1973. Straw mulch, water regime and yield. *Zemdeli No. 1:28-29 (Ru). Sibirskii Inst. Selskogo Khozyastva Omsk, USSR.*
- Sharma, K.K. 1984. Effect of water management and sowing dates on growth, development and yield of wheat. Ph.D Thesis, MPKVV, Palampur.
- Sharma, P.D., Acharya, C.L. and Bhagat, R.M. 1987. Effect of soil moisture on rainfed wheat in northern India. II. Nutrient Uptake, plant growth and yield. *Soil Tillage Res.* 9 : 79-89.
- Sharma, R.B. and Chidyal, B.P. 1977. Soil water root relation in wheat, water extraction rate of wheat roots that developed under dry and moisture conditions. *Agron. J.* 69: 231-233.
- Sharma, S.K. 1985. Studies on use of industrial organic waste, lantana and nitrogen on water use efficiency, growth and yield of rainfed and irrigated paddy. M.Sc. Thesis, H.P.K.V.V., Palampur.
- Sharma, S.K., Agarwal, G.C. and Kanwar, B.S. 1981. Response of timely and late sown peas to mulches. *J. Indian Soc. Soil Sci.* 29:371-373.
- Sharma, V.P. and Prasad, K. 1969. Studies on pure and mixed stands of barley in fertilizer application under Barani conditions. Thesis for M.Sc. degree of Post-graduate School, Indian Agricultural Research Institute, New Delhi.

- Sharma, K.C.; Singh, A. Lal, B. and Gupta, P.C. 1973. Studies on production in potential and economics of high intensity one year crop rotation under the condition of Nainital tarai. Proc. Symp. Multiple Cropping Hissar pp. 239-248.
- Sheer, G.M. and Moschler, W.W. 1969. Continuous corn by the no tillage and conventional tillage method. A six year comparison. Agron. J. 61: 524-527.
- Singh, C. and Rai, B. 1972. Linseed has a place in dry land farming. Farmers Digest 5(12): 25-27.
- Singh, R.P.; Singh, H.P.; Dauley, H.S. and Singh, K.C. 1977. Response of Brassicas to varying moisture - initial soil profile saturation and fertility levels. Indian J. Agron. 22(2): 90-95.
- Singh, G., Singhal, A.K. and Nambiar, K.M. 1967. Effect of mulching on moisture retention and yield of wheat under rainfed conditions. J. Soil and water Cons. 15: 102-107.
- Smika, D.E. and Ellis, R. 1971. Soil temperature and wheat straw mulch effects on wheat plant development and nutrient concentration. Agron. J. 63: 388-391.
- Stone, L.R. and Horton, M.L. 1973. Water losses from an irrigated sorghum field, water flux within and below root zone. Agron. J. 65: 492-495.
- Subbiah, B.V. and Asija, C.L. 1956. A rapid procedure for the estimation of available N in soil. Curr. Sci. 25: 328.
- Swenson, R.M.; Cole, C.W. and Sterling, D.H. 1949. Fixation of phosphate by iron and aluminium and replacement by organic and inorganic ions. Soil Sci. 67: 3-22.
- Tanka, A. 1974. Method of handling of cereals crop residues in Asian countries and related problems. Food and Fert. Tech. Centre ASPAC Ext. Bull No. 43: 29.
- Tanka, A. 1977. Role of organic matter. Paper presented in Symp. IREI, 20-23.
- Triplett, G.B. and Van Doven, D.M. 1969. Nitrogen, phosphorus and potassium fertilization of non tilled maize. Agron. J. 61: 637-639.
- Wander, I.W. and Gourby, J.H. 1943. Effect of heavy mulch in apple orchard upon several soil constituents and the mineral content of foliage and fruit. Proc. Amer. Soc. Hort. Sci. 42: 1-6.
- Weeks, W.D.; Smith, C.T. and Draki, M. 1950. Residual effects of heavy mulching in a bearing apple orchard on soil nutrients. Proc. Amer. Soc. Hort. Sci. 56: 1-14.

- William, W.A.; Mikkelsen, D.S. and Muller, J.E. 1968. Nitrogen immobilization by rice straw incorporated in lowland rice production. *Plant and Soil*. 28: 49-60.
- Yang, S.J. and Jong, E. 1971. Effect of soil water potential and bulk density on water uptake and resistance to flow of water in wheat plant. *Canad. J. Soil Sci.* 57: 211-220.
- Yoneyama, T. and Yoshida, T. 1977. Decomposition of rice residues in tropical soil. I. Nitrogen uptake by rice plants from straw incorporated fertilizer and soil. *Soil Sci. and Plant Nutr.* 23(1): 33-44.

APPENDICES

APPENDIX I

Mean weekly meteorological data for Rabi 1985-86.

Standard Week No.	Date	Temperature°C		Relative humidity (%)	Rainfall (mm)	Evapora tion (mm)	No.of bright sunshine (hrs)
		Max.	Min.				
42	18/10-24/10	22.8	11.7	47	-	22.8	10.0
43	25/10-31/10	23.1	11.5	45	-	17.6	9.3
44	1/11- 7/11	21.8	11.2	45	-	17.5	6.8
45	8/11-14/11	20.3	9.9	48	-	21.2	6.1
46	15/11-21/11	20.5	9.2	42	-	18.4	8.2
47	22/11-28/11	19.2	7.9	48	-	17.6	8.2
48.	29/11- 5/12	16.8	7.3	30	-	17.7	6.5
49	6/12-12/12	18.2	7.3	40	-	18.4	6.4
50	13/12-19/12	17.8	7.7	42	2.2	15.8	4.0
51	20/12-26/12	16.7	7.0	55	.	18.0	4.7
52	27/12- 2/1	13.9	4.0	57	139.5	17.1	4.1
1	3/1 - 9/1	15.1	3.4	42	-	15.3	8.8
2	10/1 -16/1	14.9	4.6	48	-	14.3	7.5
3	17/1 -23/1	15.0	3.7	41	-	15.0	8.2
4	24/1 -30/1	15.4	6.1	43	-	9.4	3.3
5	31/1 - 6/2	14.5	5.9	41	0.2	17.6	3.3
6	7/2 -13/2	16.4	6.7	54	35.2	20.8	3.3
7	14/2 -20/2	12.9	4.6	59	42.2	16.4	4.9
8	21/2 -27/2	15.0	5.4	53	40.4	18.2	5.8
9	28 /2 - 6/3	18.6	7.4	46	-	21.7	9.3
10	7/3 -13/3	21.6	11.1	41	1.2	25.6	6.8
11	14/3 -20/3	17.5	8.1	58	86.7	26.3	3.2
12	21/3 -27/3	16.1	6.2	47	21.6	24.1	5.2
13	28/3 - 3/4	21.5	12.2	42	0.8	25.3	5.8
14	4/4 -10/4	22.2	11.1	32	1.6	29.7	7.7
15	11/4 -17/4	26.8	15.6	38	3.2	43.1	7.9
16	18/4 -26/4	22.8	16.1	29	33.6	52.2	9.4

APPENDIX II

Mean weekly soil temperature (°C)

	Oct. 1985				Nov. 1985				Dec. 1985				Jan. 1986				Feb.				March				April			
	III	IV	I	II	III	IV	I	II	III	IV	I	II	III	IV	I	II	III	IV	I	II	III	IV	I	II	III	IV		
<u>0-20cm depth</u>																												
Mulch	16.8	17.1	16.4	14.0	15.3	13.6	12.8	12.9	13.9	13.8	8.9	7.9	7.7	9.3	9.6	11.3	9.3	8.8	10.9	14.8	12.1	10.8	13.9	15.6	20.2	21.1		
No mulch	13.6	13.1	11.1	11.3	9.7	8.9	8.3	10.6	8.8	3.0	5.3	4.8	6.8	5.8	7.2	8.6	6.1	6.1	8.4	11.5	9.2	8.1	10.8	12.8	17.1	18.1		
<u>Evening</u>																												
Mulch	23.3	21.4	21.9	17.4	18.6	16.8	15.1	13.8	14.2	14.2	11.2	11.3	12.0	11.9	14.1	13.9	10.7	10.9	15.1	21.9	14.2	15.6	19.2	22.3	27.4	27.1		
No mulch	25.0	26.0	20.9	21.3	19.4	18.1	16.7	17.7	16.3	13.6	14.5	15.1	16.4	16.9	16.9	15.5	13.3	13.9	17.5	23.2	16.3	17.7	21.7	24.6	29.8	30.1		
<u>20-40cm depth</u>																												
Mulch	18.3	18.1	17.7	14.3	16.2	14.9	14.5	12.8	13.1	11.6	6.1	7.8	7.1	9.2	9.8	11.3	8.7	9.1	10.3	14.1	11.6	10.1	13.5	15.1	19.7	19.1		
No mulch	16.9	16.4	16.0	12.8	14.8	13.3	12.7	11.3	11.6	9.9	4.9	6.2	5.7	8.3	8.5	9.9	7.1	7.6	9.4	12.9	10.2	8.9	12.3	13.5	17.9	18.1		
<u>Evening</u>																												
Mulch	23.7	22.8	21.2	17.7	17.8	16.1	14.8	13.6	14.2	13.3	9.9	11.2	11.9	13.8	13.9	14.4	10.8	11.3	16.9	18.8	13.8	12.1	14.1	17.3	23.4	23.1		
No mulch	25.0	24.4	22.6	19.2	19.2	17.4	16.3	14.9	15.5	14.8	10.8	12.6	13.5	13.7	15.3	15.7	12.3	12.8	18.3	20.6	15.3	13.3	15.8	20.7	26.9	28.1		
<u>40-60cm depth</u>																												
Mulch	22.6	22.6	22.8	21.1	22.9	22.8	21.2	22.9	14.2	12.6	8.2	9.4	9.5	10.4	10.8	12.3	10.1	9.9	10.5	14.3	12.9	10.9	14.2	16.3	21.1	20.1		
No mulch	21.9	21.8	22.0	22.0	22.0	22.0	20.4	22.1	13.1	11.8	7.8	8.6	8.7	9.6	10.2	11.6	9.1	9.1	9.9	13.6	12.1	10.4	13.4	15.4	20.3	19.1		
<u>Evening</u>																												
Mulch	23.8	23.9	23.6	23.8	23.6	23.7	22.1	23.5	15.0	13.4	9.2	10.3	10.3	11.5	11.7	13.2	11.8	10.6	11.6	15.9	13.6	11.5	13.2	15.7	21.9	22.1		
No mulch	24.1	25.2	24.1	25.2	24.8	24.1	23.8	24.9	16.8	14.0	9.7	11.2	11.5	12.2	12.1	14.3	12.4	11.5	12.8	16.7	14.4	12.2	14.3	16.8	22.5	23.1		

APPENDIX III

Student's 't' test to compare germination count per metre row length and number of tillers/main branches per plant

Treatments	Germination count 't' (Cal.)	No. of tillers/branches per plant 't' (Cal.)
Wheat (mulch)	0.77	1.51
Wheat (no mulch)		
Barley (Mulch)	0.59	1.40
Barley (no mulch)		
Linseed (Mulch)	0.44	1.12
Linseed (no mulch)		
Mustard (Mulch)	1.41	1.27
Mustard (No mulch)		
Lentil (Mulch)	0.99	1.51
Lentil (no mulch)		
't'(tab) at 5% level of probability is 1.943		
't'(tab) at 1% level of probability is 3.143		

APPENDIX IV

Student's 't' test to compare the plant height at different crop growth stages.

Treatments	30DAS t(Cal)	60DAS t(Cal)	90DAS t(Cal)	120DAS t(Cal)	150DAS t(Cal)	At harvest t(Cal)
Wheat(mulch)	5.94	2.71	2.71	3.46	2.16	5.74
Wheat(no mulch)						
Barley(mulch)	7.87	4.14	2.70	2.86	2.10	2.73
Barley(no mulch)						
Linseed(mulch)	0.14	0.68	0.61	1.79	2.54	2.51
Linseed(no mulch)						
Mustard(mulch)	0.68	0.57	1.48	1.81	2.04	2.34
Mustard(no mulch)						
Lentil(mulch)	0.11	0.47	0.62	0.92	2.59	-
Lentil(no mulch)						
t(tab) at 5% level of probability is 1.943						
t(tab) at 1% level of probability is 3.143						

APPENDIX V

Student's 't' test to compare days to flowering and days to maturity

Treatments	Days to flowering t (Cal)	Days to maturity t(Cal)
Wheat (mulch)	6.08	3.02
Wheat (no mulch)		
Barley(mulch)	6.74	3.49
Barley(no mulch)		
Linseed(mulch)	4.85	3.04
Linseed(no mulch)		
Mustard(mulch)	3.51	2.63
Mustard(no mulch)		
Lentil(mulch)	3.62	3.35
Lentil(no mulch)		

APPENDIX VI

Student's 't' test to compare effective tiller/branches and non-effective tiller/branches per plant

Treatments	Number of effective tillers/branches t(Cal)	Number of non-effective tillers/branches t (Cal)
Wheat (mulch)	2.30	0.34
Wheat (no mulch)		
Barley (mulch)	2.14	0.54
Barley(no mulch)		
Linseed(mulch)	2.14	0.54
Linseed(no mulch)		
Mustard(mulch)	2.96	0.40
Mustard(no mulch)		
Lentil(mulch)	2.29	0.40
Lentil(no mulch)		

t (Tab) at 5% level of probability is 1.943

t (tab) at 1% level of probability is 3.143

APPENDIX VII

Student's 't' test to compare number of grains per pod/ per ear/per siliqua and 1000-grain weight

Treatments	Number of grain per ear t(cal.)	1000-grain weight(g) t(cal.)
Wheat (mulch)	2.29	1.40
Wheat (no mulch)		
Barley(mulch)	2.23	0.63
Barley(no mulch)		
Linseed (mulch)	2.47	1.08
Linseed (no mulch)		
Mustard (mulch)	2.03	0.90
Mustard (no mulch)		
Lentil (mulch)	0.98	0.65
Lentil (no mulch)		

t(tab.) at 5% level of probability is 1.943
t(tab.) at 1% level of probability is 3.143

APPENDIX VIII

Analysis of variance for wheat equivalent yields

Source of variation	d.f.	Mean sum of squares	
		Grain yield	Straw yield
Replication	3	27.87	14.06
Crops	4	345.94	453.39
Mulches	1	360.72	632.90
Crop x Mulch	4	6.62	5.97
Error	27	12.94	13.40

APPENDIX IX

Mean treatment effects on depthwise seasonal water use (cm) at different crop growth stages - wheat.

Treatment/ depth	30DAS	60DAS	90DAS	120DAS	150DAS	At harvest	Cumulati
<u>Mulch</u>							
0-20cm	1.48 (49.66)	2.12 (43.00)	2.89 (39.05)	3.06 (28.95)	2.65 (27.38)	2.37 (30.64)	14.51 (33.67)
20-40cm	1.23 (41.27)	1.87 (37.93)	2.97 (40.14)	3.89 (36.80)	3.14 (32.44)	2.49 (33.02)	15.59 (36.17)
40-60cm	0.27 (9.07)	0.94 (19.07)	1.54 (20.81)	3.62 (34.25)	3.89 (40.18)	2.74 (36.34)	13.00 (30.16)
Total 0-60cm	2.98 (6.94)	4.93 (11.43)	7.40 (17.16)	10.57 (24.52)	9.68 (22.46)	7.54 (17.40)	43.10
<u>No mulch</u>							
0-20cm	1.58 (48.47)	2.28 (43.26)	2.93 (37.18)	3.11 (28.64)	2.71 (27.51)	2.37 (30.35)	14.98 (33.34)
20-40cm	1.31 (40.18)	1.96 (37.19)	1.80 (22.85)	3.72 (34.26)	3.19 (32.39)	2.58 (33.03)	14.56 (32.41)
40-60cm	0.37 (11.35)	1.03 (19.55)	3.15 (39.97)	4.03 (37.10)	3.95 (40.10)	2.86 (36.62)	15.39 (34.25)
Total 0-60cm	3.26 (7.25)	5.27 (11.73)	7.88 (17.54)	10.86 (24.16)	9.85 (21.32)	7.81 (17.38)	44.93

Figures in parenthesis indicate the per cent moisture contribution.

APPENDIX X

Mean treatment effects on depthwise seasonal water use at different crop growth stages (cm)-barley.

Depth	30DAS	60DAS	90DAS	120DAS	150DAS	At harvest	Cumulativ
<u>Mulch</u>							
0-20cm	1.55 (56.16)	2.43 (45.42)	2.18 (27.92)	2.63 (31.01)	2.45 (29.84)	1.32 (27.27)	12.56 (33.72)
20-40cm	0.80 (28.98)	1.85 (34.58)	2.92 (37.39)	2.87 (33.84)	2.96 (36.05)	1.63 (33.68)	13.03 (34.98)
40-60cm	0.41 (14.86)	1.07 (20.00)	2.71 (34.69)	2.98 (35.14)	2.80 (34.11)	1.89 (39.05)	11.66 (31.30)
Total 0-60cm	2.76 (7.40)	5.35 (14.26)	7.81 (20.76)	8.48 (22.56)	8.21 (22.04)	4.84 (12.98)	37.25
<u>No mulch</u>							
0-20cm	1.87 (47.58)	2.34 (45.17)	2.53 (30.48)	2.39 (29.62)	2.73 (31.27)	1.39 (27.69)	13.25 (33.78)
20-40cm	1.27 (32.32)	1.79 (34.56)	3.05 (36.75)	2.53 (31.35)	2.99 (34.25)	1.68 (33.47)	13.31 (33.93)
40-60cm	0.79 (20.10)	1.05 (20.27)	2.72 (32.77)	3.15 (39.03)	3.01 (34.18)	1.95 (38.84)	12.67 (32.29)
Total 0-60cm	3.93 (10.03)	5.18 (13.20)	8.30 (21.16)	8.07 (20.57)	8.73 (22.25)	5.02 (12.79)	39.23

Figures in parenthesis indicate the per cent moisture contribution.

APPENDIX XI

Mean treatment effects on depthwise seasonal water use at different crop growth stage (cm) -Linseed

Treatment/ Depth	30 DAS	60DAS	90 DAS	120DAS	150DAS	At harvest	Cumulative
	<u>Mulch</u>						
0-20 cm	1.69 (50.90)	2.59 (43.31)	3.15 (30.23)	2.43 (31.44)	1.98 (27.09)	1.08 (20.61)	12.92 (34.16)
20-40cm	1.07 (32.23)	2.06 (34.45)	2.61 (31.68)	3.05 (39.46)	2.27 (31.05)	1.81 (34.54)	12.87 (34.03)
40-60cm	0.56 (16.87)	1.33 (22.24)	2.48 (30.09)	2.25 (29.10)	3.06 (41.86)	2.35 (44.85)	12.03 (31.81)
Total 0-60cm	3.32 (8.78)	5.98 (15.81)	8.24 (21.79)	7.73 (20.44)	7.31 (19.33)	5.24 (13.85)	37.82
	<u>No mulch</u>						
0-20cm	2.11 (46.58)	2.89 (41.34)	2.97 (45.76)	2.45 (29.80)	2.03 (26.92)	1.15 (18.67)	13.60 (34.06)
20-40 cm	1.45 (32.00)	2.37 (33.91)	2.29 (38.29)	3.17 (30.56)	2.34 (31.03)	2.12 (34.42)	13.74 (34.41)
40-60cm	0.97 (21.42)	1.73 (24.75)	1.23 (10.95)	2.60 (31.64)	3.17 (42.05)	2.89 (46.91)	12.59 (31.53)
Total 0-60 cm	4.53 (11.34)	6.99 (17.50)	6.49 (16.26)	8.22 (20.58)	7.54 (19.88)	6.16 (15.43)	39.93

Figures in parenthesis indicate the per cent moisture contribution.

APPENDIX XII

Treatment effects on depthwise seasonal water use at different crop growth stages (cm)-Mustard

Treatment/ depth	30DAS	60DAS	90 DAS	120DAS	Harvest	Cumulative
0				Mulch		
0-20cm	1.23 (42.56)	2.37 (42.86)	4.71 (36.97)	3.09 (40.88)	1.15 (22.03)	12.55 (36.98)
20-40cm	1.05 (36.33)	2.01 (36.35)	4.57 (35.87)	2.34 (30.95)	1.69 (32.38)	11.66 (34.35)
40-60cm	0.61 (21.11)	1.15 (20.79)	3.46 (27.16)	2.13 (28.17)	2.38 (45.59)	9.73 (28.67)
Total 0-60cm	2.89 (8.52)	5.53 (16.29)	12.74 (37.54)	7.56 (22.27)	5.22 (15.38)	33.94
				No mulch		
0-20cm	1.79 (42.82)	3.17 (41.65)	4.23 (38.28)	2.01 (28.55)	1.19 (22.16)	12.39 (35.15)
20-40cm	1.45 (34.69)	2.63 (34.56)	3.75 (33.94)	2.93 (41.62)	1.74 (32.40)	12.50 (35.46)
40-60cm	0.94 (22.49)	1.31 (23.79)	3.07 (27.78)	2.10 (29.83)	2.44 (45.44)	10.36 (29.39)
Total 0-60cm	4.18 (11.85)	7.61 (21.58)	11.05 (31.36)	7.04 (19.97)	5.37 (15.24)	35.25

Figures in parenthesis indicate per cent moisture contribution.

APPENDIX XIII

Treatment effect on depthwise seasonal water use at different crop growth stages (cm) - Lentil.

Treatment/ depth	30DAS	60DAS	90 DAS	120DAS	150DAS	Harvest	Cumulative
Mulch							
0-20cm	1.58 (52.31)	2.47 (47.66)	4.39 (37.55)	2.89 (39.65)	2.11 (29.97)	1.17 (26.12)	14.61 (37.75)
20-40cm	0.98 (32.46)	1.63 (31.47)	3.67 (31.39)	2.25 (30.86)	2.56 (36.36)	1.39 (31.03)	12.48 (32.25)
40-60cm	0.46 (15.23)	1.03 (20.85)	3.63 (31.06)	2.15 (29.49)	2.37 (33.67)	1.92 (42.85)	11.61 (30.00)
Total 0-60cm	3.02 (7.80)	5.18 (13.38)	11.69 (30.22)	7.29 (18.84)	7.04 (18.19)	4.48 (11.57)	38.70
No mulch							
0-20cm	1.88 (47.96)	3.43 (49.42)	4.17 (39.53)	2.76 (43.53)	2.24 (30.23)	1.23 (26.39)	15.71 (39.46)
20-40cm	1.28 (32.65)	2.07 (29.02)	3.53 (33.46)	2.09 (32.96)	2.74 (36.98)	1.47 (31.55)	13.16 (33.09)
40-60cm	0.76 (19.39)	1.44 (20.75)	2.85 (27.01)	1.49 (30.51)	2.43 (32.79)	1.96 (42.06)	10.93 (27.45)
Total 0-60cm	3.92 (9.84)	6.94 (17.43)	10.55 (26.49)	6.34 (15.92)	7.41 (18.62)	4.66 (11.70)	39.82

Figures in parenthesis are the per cent moisture contribution values.

APPENDIX XIV

Analysis of variance for N, P and K after harvest (kg/ha)

Source of variation	d.f.	Mean sum of squares		
		N	P	K
Replication	3	1196.60	124.32	13298.80
Crops	4	7774.02	29.83	2416.31
Mulches	1	38688.40	232.81	22184.12
Crop x Mulch	4	246.69	9.35	664.62
Error	27	804.52	38.72	2169.03

APPENDIX XV

Cost of cultivation of wheat crop excluding variable cost

Sr. No.	Item	Quantity	Rate(Rs.)	Cost (Rs.)
1.	Field preparation			
	i. One ploughing (Tractor)			
	ii. Two harrowing (-do-)	2 Hrs.	40/hr.	80.00
	iii. One levelling (-do-)			
2.	Fertilizer (N,P,K 90:45:45)			
	i. Urea (46%N)	195 kg	117.00/q	229.10
	ii. SSP (16% P ₂ O ₅)	280 kg	94.00/q	263.20
	iii. MOP (60% K ₂ O)	75 kg	130.00/q	97.50
3.	Seed	120 kg	260.00/q	312.00
4.	Layout, sowing and fertilizer application	25 labourer	12.00/labour	300.00
5.	Weeding and Interculture operations	15 "	12.00/labour	180.00
6.	Harvesting	20 "	12.00/labour	240.00
7.	Threshing and winnowing	20 "	12.00/labour	240.00
8.	Rent of land	6 months	20.00/month	120.00
			Total	2061.80
	Interest on capital for 6 months @ 14% per annum			144.32
			Grand total	2206.12
	Treatment cost/variable cost			500.00

APPENDIX XVI

Cost of cultivation of barley crop excluding variable cost

<u>Sr.No.</u>	<u>Item</u>	<u>Quantity</u>	<u>Rate(rs.)</u>	<u>Cost (rs.)</u>
1.	Field preparation			
	i. One ploughing (tractor)			
	ii. Two harrowing (-do-)	2 hrs.	40.00/hr	80.00
	iii. One levelling (-do-)			
2.	Fertilizer(N-40, P-20 kg/ha)			
	i. Urea (46% N)	85kg	117.50/q	99.90
	ii. SSP (16% P ₂ O ₅)	250 kg	94.00/q	235.00
3.	Seed	120 kg	22.50 22.50/q	270.00 270.00
4.	Layout, sowing and fertilizer application	25 labourer	12.00/labour	300.00 300.00
5.	Interculture operations	10 "	"	120.00
6.	Harvesting	20 "	"	240.00
7.	Threshing and winnowing	20 "	"	240.00
8. R	Rent of land	6 months	20.00 20.00/month	120.00 120.00
			Total	1704.90
	Interest on capital for 6 months @ 14% per annum			119.34
			Grand total	1824.24
			treatment cost/variable cost	500.00

APPENDIX XVII

Cost of cultivation of linseed crop excluding variable cost

<u>Sr.No.</u>	<u>Item</u>	<u>Quantity</u>	<u>Rate(Rs.)</u>	<u>Cost (Rs.)</u>
1.	Field preparation			
	i. One ploughing (Tractor)			
	ii. One levelling (Tractor)	2 hrs.	40.00/hr	80.00
	iii. Two harrowing (Tractor)			
2.	Fertilizer (N:50,P:40,K:20)(kg/ha)			
	i. Urea (46% N)	110 kg	117.50/q	129.25
	ii. SSP (16% P ₂ O ₅)	250 kg	94.00/q	235.00
	iii. MOP (60% K ₂ O)	33 kg	130.00/q	42.90
3.	Seed	30 kg	800.00/q	240.00
4.	Layout, sowing and fertilizer application	20 Labourer	12.00/labour	240.00
5.	Intercultural operations	10 "	"	120.00
6.	Harvesting	18 "	"	216.00
7.	Threshing and winnowing	20 "	"	240.00
8.	Land rent	6 month	20.00/month	120.00
			Total	1663.15
	Interest on capital for 6 months @ 14% per annum			116.42
			Grand total	1779.57
			Treatment cost/variable cost	500.00

APPENDIX XVIII

Cost of cultivation of mustard crop excluding variable cost

<u>Sr.No.</u>	<u>Item</u>	<u>Quantity</u>	<u>Rate(Rs.)</u>	<u>Cost(Rs.)</u>
1.	Field Preparation			
	i. One ploughing (Tractor)			
	ii. Two harrowing (")	2 hrs.	40.00/hr	80.00
	iii. One levelling (")			
2.	Fertilizers			
	i. Urea (46% N)	130kg	117.50/q	152.75
	ii. SSP (16% P ₂ O ₅)	250kg	94.00/q	235.00
	iii. MOP (60% K ₂ O)	65kg	130.00/q	84.50
3.	Seed	6kg	900.00/q	54.00
4.	Layout, sowing and fertilizer application	20 Labourer	12.00/labour	240.00
5.	Weeding and interculture operation	10 "	"	120.00
6.	Harvesting	15 "	"	180.00
7.	Threshing and winnowing	17 "	"	204.00
8.	Land rent	6 month	20.00/month	120.00
			Total	1470.25
	Interest on capital for 6 months @ 14% per annum			102.91
			Grand total	1573.16
	Treatment cost/variable cost			500.00

APPENDIX XIX

Cost of cultivation of lentil crop excluding variable cost

<u>Sr.No.</u>	<u>Item</u>	<u>Quantity</u>	<u>Rate(Rs.)</u>	<u>Cost (Rs.)</u>
1.	Field preparation			
	i. One ploughing(Tractor)			
	ii. Two harrowing(Tractor)	1.2hrs	40.00/hr	60.00
	iii. One levelling(Tractor)			
2.	Fertilizer (N:10,P:40 kg/ha)			
	i. Urea (46% N)	25kg	117.50/q	29.40
	ii. Superphosphate(16% P ₂ O ₅)	250kg	94.00/q	235.00
3.	Seed	30 kg	700.00/q	210.00
4.	Layout,sowing and fertilizer application	20 labourer	12.00/labour	240.00
5.	Weeding and Interculture operation	10 "	"	120.00
6.	Harvesting	15 "	"	180.00
7.	Threshing and winnowing	20 "	"	240.00
8.	Land rent	6 months	20.00/month	120.00
			Total	1434.40
	Interest on capital for 6 months @ 14% per annum			100.40
			Grand total	1534.80
	Treatment cost/variable cost			500.00

APPENDIX XX

Economics of rainfed rabi crops

Crops	Level of Mulch	Grain cost Rs.	Straw cost Rs.	Total cost Rs.	Cost of cultivation Rs.	Net return Rs.	Net return/ rupee invested Rs.
Wheat	Mulch	4154.70	1597.00	5751.70	2706.12	3045.58	1.12
	No mulch	3159.75	1179.00	4338.75	2206.12	2132.63	0.96
Barley	Mulch	2912.45	1132.00	4044.45	2324.24	1720.21	0.74
	No mulch	2146.75	814.00	2960.75	1824.24	1136.51	0.62
Linseed	Mulch	5572.00	1127.00	6699.00	2279.57	4419.43	1.93
	No mulch	4168.00	781.00	4949.00	1779.57	3169.43	1.78
Mustard	Mulch	2869.00	691.00	3556.00	2073.16	1482.84	0.71
	No mulch	2136.00	453.00	2589.00	1573.16	1015.84	0.64
Lentil	Mulch	5060.20	916.00	5982.20	2034.80	3947.40	1.94
	No mulch	3654.40	643.00	4497.40	1534.80	2963.60	1.90