

Development of Tractor Operated Semi - Automatic Two Row Turmeric Planter

Thesis

*Submitted to the Dr. Rajendra Prasad Central Agricultural
University in partial fulfilment of the requirements for the award of
the degree of*



**Master of Technology in Agricultural Engineering
(Farm Machinery and Power Engineering)**

By

**AKHILESH BARIHA
(MT/FMPE/525/2020-21)**

**Department of Farm Machinery and Power Engineering
College of Agricultural Engineering and Technology
Dr. RAJENDRA PRASAD CENTRAL AGRICULTURAL UNIVERSITY
PUSA (SAMASTIPUR) – 848125 BIHAR
(2022)**

Dr. RAJENDRA PRASAD CENTRAL AGRICULTURAL UNIVERSITY
PUSA (SAMASTIPUR) 848125



Date: 15/09/2022

Certificate

This is to certify that the work recorded in this thesis in entitled “**Development of Tractor Operated Semi - Automatic Two Row Turmeric Planter**” submitted in the partial fulfilment of the requirements for the award of degree of **Master of Technology in Agricultural Engineering (Farm Machinery and Power Engineering)** in the College of Agricultural Engineering and Technology, Dr. Rajendra Prasad Central Agricultural University, Pusa is the faithful record of *bona fide* research work carried out by **Mr. Akhilesh Bariha** under my supervision and guidance. No part of this thesis has ever been published or submitted for any other degree or diploma.

The assistance and help received during the course of investigation and source of literature have been duly acknowledged.

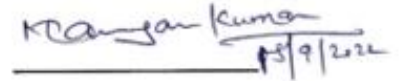
15/9/2022

Er. Manoranjan Kumar

Chairman

Advisory Committee

ENDORSED

27/09/2022

(Dr. S.K. Patel)

Head

Department of Farm Machinery and Power Engineering
Dr. Rajendra Prasad Central Agricultural University
Pusa, Samastipur, Bihar

Certificate

We, the undersigned, members of the Advisory Committee of **Mr Akhilesh Bariha**, a candidate for the degree of **Master of Technology in Agricultural Engineering (Farm Machinery and Power Engineering)** have gone through the manuscript of the thesis entitled **“Development of Tractor Operated Semi - Automatic Two Row Turmeric Planter”** may be submitted by him in the partial fulfilment of the requirements for the award of the said degree of the Dr. Rajendra Prasad Central Agricultural University, Pusa, (Samastipur) Bihar.

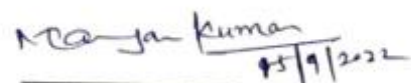
15/9/2022

(Er. Manoranjan Kumar)

Chairman

Advisory Committee

Members of the Advisory Committee

15/9/2022

(Dr. Subhash Chandra)

Assistant Professor, FMPE

15/9/22

(Dr. Mahesh Kumar)

Assistant Professor, SMCA

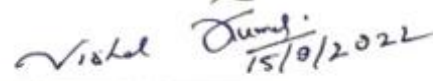
15/9/2022

(Dr. Vishal Kumar)

Assistant Professor, PFE

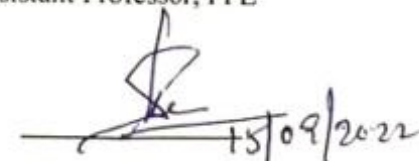

15/09/2022

(Dr. S.K. Sahoo)

Associate Professor, Entomology
Nominee of Director of Education

Certificate

This is to certify that the thesis entitled “**Development of Tractor Operated Semi - Automatic Two Row Turmeric Planter**” submitted by **Mr. Akhilesh Bariha**, in the partial fulfilment of the requirements for the award of degree of **Master of Technology in Agricultural Engineering (Farm Machinery and Power Engineering)** in the College of Agricultural Engineering and Technology, Dr. Rajendra Prasad Central Agricultural University, Pusa (Samastipur) Bihar was examined and approved on 25/11/22

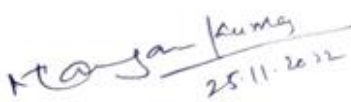

External Examiner

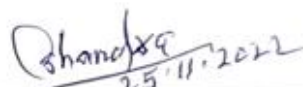

(Er. Manoranjan Kumar)
Assistant Professor, FMPE
Chairman and Major Advisor

Members of the Advisory Committee

(Dr. Subhash Chandra)
Assistant Professor, FMPE

(Dr. Mahesh Kumar)
Assistant Professor, BS&L, SMCA

(Dr. Vishal Kumar)
Assistant Professor, PFE

(Dr. S.K. Sahoo)
Associate Professor, Entomology
Nominee of Director of Education

(Dr. S.K. Patel)
Head
Department of Farm Machinery and Power Engineering
College of Agricultural Engineering and Technology,
RPCAU, Pusa (Samastipur) Bihar

ACKNOWLEDGEMENT

Before giving way to our feelings, we cordially want to salute the supreme cosmic consciousness from which everything originates in the beginning and to which everything goes to end and the memories of our parents. Though formal and deed words cannot carry the fragrance of emotion with them still they are only available way of expressing emotions. Our acknowledgement is much more than what we are expressing here.

Out of all the supporters I would like to put in first position, with immense gratitude, my esteemed guide Er. Manoranjan Kumar, Assistant Professor, Department of Farm Machinery and Power Engineering, RPCAU, Pusa for imparting all his experience, knowledge and skills in me, for his caring behaviour and his continuous efforts to accommodate a supportive environment while carrying out my research, in spite of his multifarious responsibilities.

Our sincere appreciation goes to Dr. Ambrish Kumar, Dean, CAET, RPCAU, Pusa, Samastipur and Dr. S.K. Patel, Head of Department, Farm Machinery and Power Engineering, College of Agricultural Engineering and Technology, RPCAU, Pusa, and for providing necessary facilities and academic cooperation in this venture and for their valuable guidance, suggestions, kind cooperation and care made the research period calm and residence peaceful.

It gives me great pleasure in acknowledging the support and help of the members of my advisory committee Dr. Subhash Chandra, Assistant Professor, FMPE, Dr. Mahesh Kumar, Assistant Professor, SMCA, Dr. Vishal Kumar, Assistant Professor, PFE, Dr. S.K. Sahoo, Associate Professor, Entomology (Director of Education's Nominee) for their generous gestures and critical suggestions during the course of investigation.

I am very much thankful to Dr. M. N. Jha, Director of Education, RPCAU, Pusa.

I am very delighted to express my thanks to the Vice-Chancellor, RPCAU, Pusa for providing me the financial assistance in the form of fellowship during my post-graduation studies.

I am equally indebted to Er. Kranti Kumar, Associate Professor, Dr. P.K. Pranav, Associate Professor, Dr. Jaya Sinha, Assistant Professor, Er. Shailesh Kumar Assistant Professor, Er. Abhishek Ansh, SRF, Er. Ujjawal Chouhan, Junior Engineer and Er. Gaurav

Raj, Junior Engineer; Department of Farm Machinery and Power Engineering, RPCAU, and all the staff member of FMTC, for their kind help and suggestions.

It would have been a very tough job for me to complete this thesis without continuous support of my friends. I am indebted to my colleagues Shubham Chaudhary, Gaurav Kumar, Niranjana Kumar (Department of Farm Machinery and Power Engineering) Madhusudan Sinha, Souvik Pal, Abhinav Kumar, Reema Das (Department of Soil and Water Conservation Engineering), Anshul Kumar Verma, Vivek Pandey (Department of Processing and Food Engineering) for their regular moral support, motivation and inspiration and juniors Nitin, Tonmay, Anand, Ajay, Mukesh, Tarun, Rajat, Neeraj for their regular help during the conduct of investigation.

Finally, I would like to express deepest sense of reverence and indebtedness to my parents: Mr. Madhusudan Bariha and Mrs. Sulochana Bariha, who gave me my name, my life, and everything else in between. I always love and appreciate them for the efforts they have put into giving me the life I have now. I also express my deep affection to my sister Priyanka Bariha and Meenakshi Bariha and all other well-wishers whose incessant love, affection and encouragement brought the present task to completion.

Last but never least; I will always be grateful to eternal “Mother NATURE”, who is my source of wisdom, inspiration, strength, knowledge and everything necessary for my life and the Farmers of India for their hard work and sacrifice for providing us “food” the necessity of life.

Place: RPCAU, Pusa

Date: 15/09/2022

Akhilesh Bariha



FARM MACHINERY AND POWER ENGINEERING
College of Agricultural Engineering and Technology
Dr. Rajendra Prasad Central Agricultural University,
Pusa (Samastipur) – 848125 Bihar

Post-Graduate Degree Programme	: M.Tech.-Agril. Engg. (FM&PE)
Department	: Farm Machinery and Power Engineering
Name of Student	: Akhilesh Bariha
Registration No.	: MT/FMPE/525/2020-21
Major Subject	: Farm Machinery and Power Engineering
Minor Subject	: Agricultural Statistics
Major Advisor	: Er. Manoranjan Kumar, Asst. Prof.
Title of Research Problem	: Development of Tractor Operated Semi-Automatic Two Row Turmeric Planter

ABSTRACT

Turmeric can be grown in tropical areas that are hot and humid. Manual turmeric planting takes time and effort, as a worker has to dig the soil, sow the turmeric on the field and cover the turmeric with the soil. Due to a shortage of skilled labours, the Farmer faced a problem with turmeric sowing. If planting is mechanized then the area under turmeric can be increased. The planter will remove human drudgery during planting and also improve the quality of planting. Therefore, two row semi-automatic tractor operated turmeric planter was developed at the department of Farm Machinery and Power Engineering, College of Agricultural Engineering and Technology, RPCAU Pusa.

The planter consists of a main frame, seed metering mechanism, seed hopper, ground wheel, furrow opener, ridger, power transmission unit and operator seat. The developed turmeric planter was tested in the laboratory as well as field for its performance.

The planter provides seed rate 2201.19 kg/ha. The theoretical field capacity was observed that 0.067 ha/h, 0.09 ha/h and 0.112 ha/h at the speed of 0.75 km/h, 1.00 km/h and 1.25 km/h respectively. The effective field capacity was observed that 0.059 ha/h, 0.077 ha/h and 0.09 ha/h at the speed of 0.75 km/h, 1.00 km/h and 1.25 km/h respectively. The field

efficiency was observed that 88.05%, 85.55% and 80.35% at the speed of 0.75 km/h, 1.00 km/h and 1.25 km/h respectively. Missing and multiple percentage of seeds increased as the speed increased. The cost of sowing by planter was observed at 11425 Rs/ha at the speed of 1.00 km/h and by manual it was 19250 Rs/ha.

CONTENTS

Chapter	Title	Page No.
	List of Tables	I
	List of Figures	II
	List of Symbol and Abbreviations	III
I	INTRODUCTION	1-5
II	REVIEW OF LITERATURE	6-13
	2.1 Cultivation Methods of Turmeric	6
	2.2 Engineering Properties of Turmeric	7
	2.3 Development of Various Planters	8
	2.4 Planter Design Factors	9
	2.5 Performance Evaluation of Planters	12
	2.6 Cost Economics	13
III	MATERIALS AND METHODS	14-34
	3.1 Crop Parameter	14
	3.2.1 Physical properties	14
	3.2.1.1 Variety of crop	14
	3.2.1.2 Weight of turmeric	14
	3.2.1.3 Length, width and thickness	14
	3.2.1.4 Moisture content	15
	3.2.2 Frictional properties	15
	3.2.2.1 Angle of repose	15
	3.2.2.2 Coefficient of friction	16
	3.2 Machine Parameter	16
	3.2.1 Considerations for the development of turmeric planter	16
	3.2.2 Development procedure	16
	3.2.2.1 Main frame	17
	3.2.2.2 Metering mechanism	18
	3.2.2.3 Seed box or hopper	19
	3.2.2.4 Seed dropping mechanism	20
	3.2.2.5 Optimization of drive wheel diameter for maintain seed to seed spacing	21

3.2.2.6	Ground wheel	21
3.2.2.7	Ridger bottom	22
3.2.2.8	Operator seat	24
3.2.2.9	Power transmission system	25
3.2.2.10	Three-point linkage	25
3.2.3	Specification of developed turmeric planter	26
3.3	Performance Evaluation of Developed Planter	28
3.3.1	Soil Parameter	28
3.3.1.1	Type of soil	29
3.3.1.2	Soil moisture content	29
3.3.1.3	Soil bulk density	29
3.3.2	Field parameter	29
3.3.2.1	Experimental site	29
3.3.2.2	Layout of experimental plot	30
3.3.2.3	Treatment	30
3.3.2.4	Field test	30
	3.3.2.4.1 Spacing between plants	30
	3.3.2.4.2 Spacing between rows	30
	3.3.2.4.3 Working width	31
	3.3.2.4.4 Depth of turmeric seed	31
3.3.2.5	Field evaluation of turmeric planter	31
	3.3.2.5.1 Uniformity of turmeric spacing	31
	3.3.2.5.2 Missing percentage	32
	3.3.2.5.3 Multiple percentage	32
	3.3.2.5.4 Quality of feed index	32
	3.3.2.5.5 Theoretical field capacity	32
	3.3.2.5.6 Effective field capacity	33
	3.3.2.5.7 Field efficiency	33
3.4	Cost of Use of Planter	33
3.4.1	Fixed cost	33
3.4.1.1	Depreciation	33
3.4.1.2	Interest	33
3.4.1.3	Insurance, taxes and housing	34

3.4.2	Variable cost	34
3.4.2.1	Repair and maintenance	34
3.4.2.2	Fuel consumption	34
3.4.2.3	Lubricating cost	34
3.4.2.4	Wages and labour charges	34
3.5	Economics of Use of Turmeric Planter	34
IV	RESULTS AND DISCUSSION	36-39
4.1	Physical Properties of Turmeric	36
4.1.1	Weight of turmeric	36
4.1.2	Moisture content	36
4.1.3	Size of turmeric	36
4.1.4	Bulk density	36
4.2	Theoretical Field Capacity, Actual Field Capacity and Field Efficiency	36
4.3	Machine Evaluation in Field	37
4.3.1	Crop parameter	37
4.3.2	Uniformity of turmeric spacing	37
4.3.3	Quality of feed index	38
4.3.4	Missing percentage	39
4.3.5	Multiple percentage	40
4.4	Cost Calculation	41
4.5	Economics of Use of Turmeric Planter	41
V	SUMMARY AND CONCLUSIONS	42
5.1	Summary	42
5.2	Conclusions	42
	Suggestion for Future Work	43
	References	i-v
	Appendix A, B, C, D, E, F, G	vi-
		xxvii

LIST OF TABLES

Table No.	Particular	Page No.
1.1	State wise area and production of turmeric	2
3.1	Different forward speed and gear ratio for optimize seed to seed spacing	21
3.2	Specification of turmeric planter	26
4.1	Theoretical field capacity, effective field capacity and field efficiency of turmeric planter	37
4.2	Spacing and depth of placement of turmeric seeds	37
4.3	Coefficient of uniformity	38
4.4	Quality of feed index	38
4.5	Missing percentage	39
4.6	Multiple percentage	40
4.7	Cost of sowing of turmeric planter	41

LIST OF FIGURES

Fig. No.	Particulars	Page No.
1.1	Yearly horticulture production rate	1
1.2	Production of spices and turmeric	3
3.1	Weighing balance	14
3.2	Digital vernier calliper	15
3.3	Metering mechanism	19
3.4	Seed box	20
3.5	Seed dropping mechanism	21
3.6	Ground wheel	22
3.7	Cross section of furrow opener	23
3.8	Side view of ridger bottom	24
3.9	Front view of ridger bottom	24
3.10	Operator seat	25
3.11	Power transmission	25
3.12	Front view of turmeric planter	26
3.13	Fabrication of turmeric planter	26
3.14	Developed turmeric planter	28
3.15	Layout of experimental plot	30
3.16	Field testing of turmeric planter	31
4.1	Uniformity of spacing	38
4.2	Quality of feed index at different speed	39
4.3	Missing percentage at different speed	39
4.4	Multiple percentage at different speed	40

ABBREVIATION AND SYMBOLS

Particular	Description
@	: At the rate of
%	: Percent
etc	: Etcetera
/	: Per
≈	: Approximate
Agril.	: Agricultural
C.V.	: Coefficient of Variation
cm	: Centimetre
°C	: Degree Centigrade
dia	: Diameter
Deptt.	: Department
<i>et al.</i>	: Et alii and other people
Fig.	: Figure
g	: Gram
g/cm ³ or g cm ⁻³	: Gram per centimetre cubic
h	: Hour
ha	: Hectare
Hp	: Horse Power
ha/h or ha h ⁻¹	: Hectare per hour
i.e.	: That is
kg	: Kilogram
km/h or km h ⁻¹	: Kilometre per hour
l	: Litter
l/ha	: Litter per hectare
m	: Meter
man-h/ha	: Man hour per hectare
mm	: Millimetre
m/s	: Meter per second
M.S.	: Mild Steel
MT	: Metric Tonne
NHB	: National Horticulture Board
RPCAU	: Rajendra Prasad Central Agricultural University
Rs	: Rupees
Rs/ha	: Rupees per hectare
rpm	: Revolution per minute
S.D.	: Standard deviation
T	: Treatments
t-ha ⁻¹	: Tonne per hectare
Wt.	: Weight

CHAPTER 1

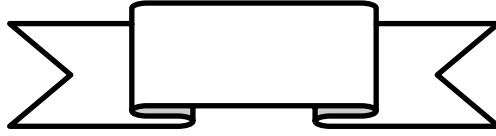

INTRODUCTION

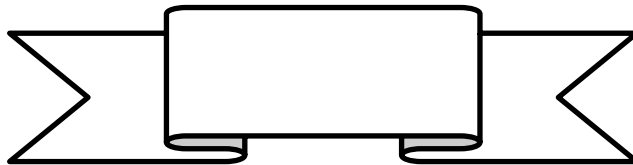

CHAPTER – I

INTRODUCTION

Horticulture is an important aspect of agriculture, accounting for 4.5 percent of the agriculture Gross Domestic Product (GDP), which is 13.7 percent in India. India produces 14 percent of the world's vegetables and is the second largest after China (49.5 percent). The remainder of the globe, including the United States, supplies the remaining demand for the vegetables (approximately 3.1 percent) (Anonymous, 2014). Vegetables accounts for about 2.8 percent of India's total planted land. The horticulture industry is gradually growing. The area under horticulture has expanded by 2.6 percent each year over the previous decade, while yearly production has climbed by 4.8 percent (Anonymous, 2018). As a result, throughout the previous decade, there has been a gradual transformation. Similarly, the total horticulture production in India (Fig. 1.1) was recorded as 319.56 MT out of 26.21 million ha during 2019-20 while 310.7 MT in 2018-19 (Anonymous, 2019 a).

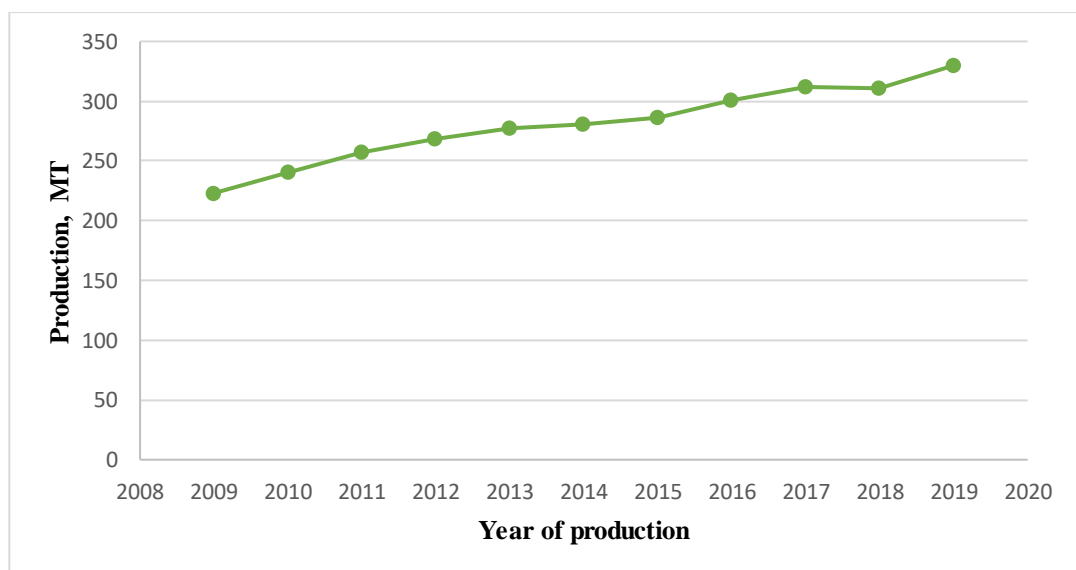

Fig. 1.1: Yearly horticulture production rate

Out of total horticulture production, spice production contributes only 3.05% of total production in 2019-20 which was 9.75 MT from 26.21 million ha area. Although the area under the horticulture is increasing year by year but contribution of spice production is completely low.

Turmeric (*Curcuma longa*) is a perennial herb that is related to ginger (*Zingiberaceae*), which is used as spice. It's known as Indian saffron, and it's also known as *Haldi*. It thrives in tropical areas that are hot and humid. Turmeric rhizomes have traditionally been employed in

both food preparation and medicinal. The turmeric is a rich bright yellow color. The underground turmeric imparts a particular flavor to food and is also used to impart a deep, permanent orange color to it.

Production of turmeric is estimated to be over 11 lakh tonnes per annum worldwide. India dominates the global production picture, accounting for 80% of total output, followed by China (8%), Myanmar (4%), Nigeria and Bangladesh (3%) each. Because turmeric is an important component of many Indian dishes and traditional remedies, largest producer and exporter of turmeric and turmeric-based products is India.

In India, roughly 2.54 lakh hectare of turmeric were planted in 2019-2020 with production of 12.29 lakhs tones. Assam, Orissa, Andhra Pradesh, Karnataka, West Bengal, Maharashtra, Telangana and Tamil Nadu are the most prominent turmeric-growing states in India. The total turmeric production of India has reduced from 1.13 MT in 2018 to 0.95 MT in 2020 (Deptt. of Agri. and Farmer Welfare- 2020).

Table 1.1: State wise area and production of turmeric

S.N.	States	Area (ha)	Production (Tonne)
1	Andhra Pradesh	28921	69410
2	Assam	15896	19395
3	Bihar	3384	8237
4	Karnataka	26579	153770
5	West Bengal	17737	45460
6	Maharashtra	17224	38310
7	Orissa	27869	43615
8	Tamil Nadu	23351	92360
9	Telangana	53104	345270

Source: Horticulture Statistics Division, Department of Agriculture, Coopn and Farmer Welfare (2020).

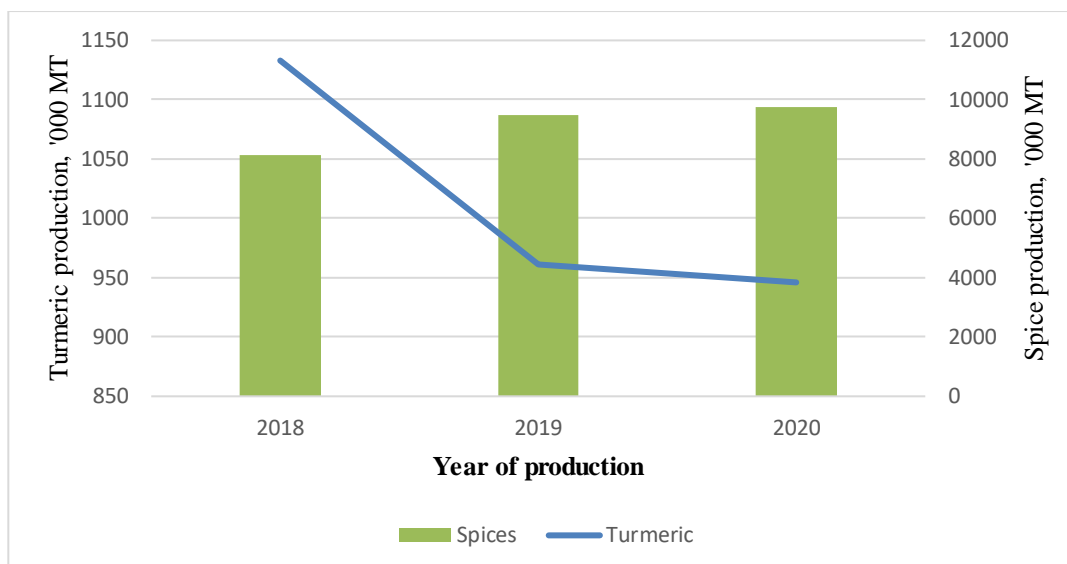

Fig. 1.2: Production of spices and turmeric (Deptt. of Agri. and Farmer Welfare, 2020)

The total area under turmeric in Bihar is 3384 ha, with an annual production of 8237 tonnes. Turmeric is primarily farmed as a significant spice crop in Bihar's northwestern districts, including Bhagalpur, Muzaffarpur, Vaishali, Samastipur, East Champaran, Madhubani, Begusarai and Sitamarhi.

The average national productivity of this crop remains low (278q/ha) due to a lack of awareness among farmers about area specific recommended package of practices, a scarcity of high yielding and resistant varieties, and a lack of adoption of recommended protection technologies and plant production. Application of appropriate fertilizer dose at the appropriate time, along with other recommended practices (interculture operation, irrigation, and so on), also play an important role in turmeric productivity (Mishra and Singh, 2017).

Planting method is a soil management tool that effect plant growth and yield (Chattopadhyay *et al.*, 1993). Tiller per plant, number of leaves per plant, Plant height, turmeric weight, and fresh turmeric yield were all significantly higher in the ride planting method that in the flat planting method, according to Gill *et al.* Individual plant yield potential is maximized when sown at wider spacing, whereas yield per unit area is maximized when individual plant is subjected to serve completion (Holiday, 1960). The type and weight of planting material used influenced plant vigor and crop yield per unit area, as well as production costs (Philip, 1985).

The physical and engineering properties of agricultural produce must be determined in order to design agriculture machinery and improve processes for harvesting, handling,

postharvest operation and storage (Kumar and Kumar, 2016). Turmeric is frequently cauterized by its physical dimensions (length, width and thickness) and density because these properties are used for sorting and grading (Keramat-Jahromi *et al.*, 2018).

Turmeric can be grown in temperature ranges of 20 to 30°C, with 1500 mm or more annual rainfall, either under irrigation conditions or irrigation. It can be cultivated in various soils such as light black, red to clay loam, ash loam. It grows best on well drained sandy or clay loam soils. A well-developed healthy, disease free whole or split maternal turmeric weight 25.44 g and is used for planting. The small hole is made of hand hoe lined up in bed at a distance of 25 x 30 cm and are covered with soil or dry powder cow dung. The spacing between rows is approximately 45 to 60 cm and 15 to 20 cm between plants. One hectare required a seeding amount of 2500 kg of turmeric (Jayashree *et al.*, 2014).

In comparison to other horticulture commodities, spice crop now has a higher market value. Spice crop give good chances for famers to increase their revenue, even in arid areas. The current study focuses on turmeric since it has a higher unit productivity and gives a lot of room for value addition. Farm activities that are quick and punctual might result in higher output. As a result, proper farm machinery should be available for particular and quick agricultural activities. Due to labour migration, the availability of labour in rural regions is now limited. As a result, the development of appropriate machinery is required to boost the productivity of turmeric production and mechanism farm activities (Kandiannam *et al.*, 2008).

Planting turmeric take time and effort. This is tedious task as workers have to manually dig the soil and sow the seed on the ground. In the current economic environment, the shortage of skilled workers makes it very difficult to increase turmeric production. 8 hours of work per day is considered a man-day. All the days when family workers and wages workers work together are counted. The current labour cost for workers working in the turmeric field is 350 Rs. Labour force for land, ridges, furrows, hoes, weeds, turmeric planting, earth work, crop preparation. On one hectare of turmeric fields, it can an average of 55 man-days (Mathanker and Mathew, 2002) to perform all the above operations, costing about 19250 Rs.

Despite of having the high commercial and medicinal value of the turmeric crop, it has been growing as a subsidiary crop in India. Not using improved varieties, unavailability of farm labours, non-availability of mechanization, are the reason for low productivity of turmeric and reduction in total cultivable area and thus production.

Hence to minimize the labour, time, energy and enhancing the production, productivity and minimize the drudgery there is need of planter for sowing of turmeric.

So turmeric planter is developed under the department of Farm Machinery and Power Engineering, College of Agricultural Engineering and Technology, RPCAU Pusa Bihar with following objective.

1. To design and develop two row semi-automatic turmeric planter.
2. To evaluate performance of developed turmeric planter in the field.

CHAPTER 2

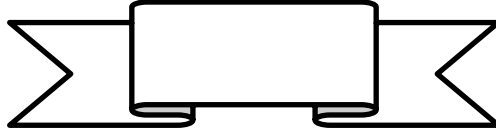

REVIEW OF LITERATURE

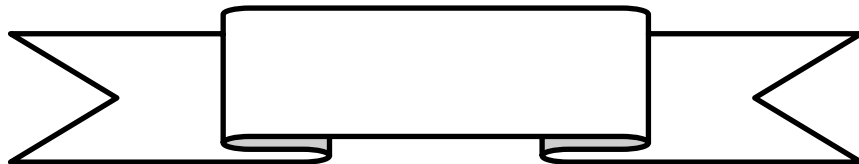

CHAPTER - II

REVIEW OF LITERATURE

This chapter gives a comprehensive review of the research work done by various research workers related to the cultivation method and physical properties of turmeric, development of planters for crop and performance evaluation.

2.1 Cultivation Methods of Turmeric

Islam *et al.* (2002) carried out a study to find the best plant spacing for maximum turmeric output. The study looked at four plant spacings: 60 x 30, 45 x 10, 45 x 30, and 45 x 20 cm. The 45 cm × 10 cm plant spacing yielded the greatest average yield of 17.87 t/ha, closely followed by the 45 cm x 20 cm plant spacing yield of 16.77 t/ha. 60 cm × 30 cm produced the lowest average output of 13.42 t/ha. They came to the conclusion that a planting geometry of 45 cm × 10 cm is adequate, but that a plant spacing of 45 cm x 20 cm is more economically viable for turmeric production.

Amzad *et al.* (2005) stated that the needed weight of turmeric seed was around 50 g of mother rhizome, which must comprise secondary and tertiary rhizomes that develop in order to mature plants with equivalent output. Aside from weight, the size of the turmeric seed is a significant consideration when selecting good turmeric seeds. Finally, the turmeric seed should be a big diameter section of the mother or primary rhizome. It should weigh between 30 and 40 g. Secondary and tertiary daughter rhizomes should be separated from turmeric seed before planting.

Kandiannan and Chandaragiri (2008) investigated the impact of variety, planting period, and spacing on turmeric yield. They came to the conclusion that the variety BSR-2 outperformed BSR-1 in terms of growth and yield. Plant spacing of 30 cm x 15 cm was observed in much greater nutrient absorption, growth, and yield than 60 cm x 15 cm and 45 cm x 15 cm.

Kumar and Gill (2010) studied the effect of planting method (flat and ridge planting) and harvesting time on turmeric growth, production, and quality. The yield of fresh turmeric was 160.3 and 164.8 q /ha in ridge planting and flat methods, respectively, highest yield was obtained by planting of mother rhizomes and the difference were non-significant, as compared to secondary and primary turmeric rhizomes, and with decrease in seed size turmeric yield decreasing significantly.

Singh and Kaur (2015) evaluated the growth and yield of turmeric using various methods of planting turmeric at farmers' Geld in the district of Hoshiarpur. The average length of turmeric rhizomes by manually planted turmeric for treatment-1 (30 cm× 20 cm), treatment-2 (45 cm ×15 cm spacing) and treatment-3 (60 cm ×15 cm spacing) after uprooting were 7.85 cm, 7.91 cm, and 8.20 cm, respectively, the mean diameter for turmeric rhizome treatment-1, treatment-2 and treatment-3 after uprooting were 3.05 cm, 2.64 cm, and 3.45 cm respectively. Turmeric per kg for treatment-1, treatment-2 and treatment-3 had 34, 30, and 24 respectively. The highest yield of turmeric rhizome (130.0 q/acre) was in treatment-3, which was 17.65% and 8.33% higher than treatment-2 and treatment-1.

2.2 Engineering Properties of Turmeric

The engineering properties such as moisture content, size, shape, and bulk density of turmeric, as reported by different researchers are reviewed and presented here.

Athmaselvi and Varadharaju (2002) investigated on the moisture content of different varieties of turmeric and found that the BSR-I and Erode local had a moisture content of 82% (w.b.) whereas the variety BSR-II had a moisture percentage of 86% (w.b.) observed immediately after the harvest.

Mathanker and Mathew (2002) investigated the design properties of turmeric seed in order to develop key dimensions for metering devices. The average length, breadth, thickness, and angle of repose of turmeric seed were 72.35 mm, 49.28 mm, 19.23 mm, and 38 to 41.5°, respectively, while the average weight of turmeric by hand preparation was 26.75 g.

Mishra and Kulkarni (2009) determined the mean length, breadth, and thickness of turmeric (variety-Sangli) as 42.77, 10.85, and 9.51 mm, respectively, at 12.4% moisture in dry basis, the porosity, true density, bulk density and terminal velocity of turmeric rhizome were observed as 50.37%, 1253.93 kg/m³, 622.33 kg/m³, and 7.22 m/s respectively.

Balasubramaniam *et al.* (2012) observed the physical properties of turmeric rhizomes which were divided in 3 different grades namely, Grade-I (25-35 mm), Grade-II (35-45 mm) and Grade-III (45-55 mm). The mean values of length, breadth and thickness were varying from 30.38-50.60 mm, 9.77-10.64 mm, and 5.18-6.44 mm respectively. Some other physical properties were arithmetic mean diameter (15.82- 21.91 mm), geometric mean diameter (12.77- 13.76 mm), aspect ratio (0.20-0.35), sphericity (0.27-0.42) equivalent diameter (17.61-21.41 mm). Some observation so gravimetric properties were also done which showed that rhizomes

had true density of 1341-1354 kg/m³, bulk density of 260-348 kg/m and porosity of 74.53-80.93%. The frictional properties of rhizomes observed were angle of repose (37.57-38.90°) and the coefficient of friction was conducted in 3 different surfaces (aluminium sheet, mild steel sheet, and plywood sheet) for all varieties and observed the values of 0.69-81 for aluminium, 0.84-0.94 in mild steel and 0.80-0.86 in plywood.

2.3 Development of Various Planters

Sahoo and Srivastava (2000) developed a machine for ridge planting of wet okra seed and named the machine as three-row ridger planter. The inclined plate seed metering mechanism was used in the planter. Using chain and sprockets, transfer of power from ground wheel to seed metering mechanism was done. For producing ridges, the machine included four ridger bottoms with runner style furrow openers. The seed was planted at the proper depth in these ridges. The ridge size and depth of seed placement were also adjustable. A 35-horsepower tractor drove the implement. The observed field capacity of planter was 0.2ha/h at a speed of 2.27 km/h. The planter had an efficiency of 66.5% in the field.

Kazmeinkhah (2007) developed a semi-automatic transplanter mechanism for growing sugar beet seedlings. The developed machine could nurture seedlings with a row distance of 65 cm, a depth of 13 cm, and a seedling distance of 50.30 cm.

Anon (2010) designed a tractor-operated garlic planter at MPUAT with a star wheel seed and fertilizer metering system. The 12-row unit's key characteristics are the two-row paired hopper and adjustable seed rate, with a minimum row spacing of 150 mm. During testing, the observed seed rate ranged from 500 to 700 kg/ha, with the size of the garlic cloves being the most important factor. Garlic cloves were spaced 50 to 100 mm apart. The field efficiency, field capacity, and planting cost were 70%, 0.35 ha/h and 1300 Rs/ha, respectively.

Vasuki (2012) developed a tractor powered turmeric planter that includes a main frame, cup feed seed metering mechanism, seed hopper, ground wheel, ridger bottom, chain sprocket power transmission drive and shoe type furrow opener. The performance of the turmeric planter was tested in the lab and field. The missing index, singles, doubles and triples of the turmeric planter were 15.95%, 67.9%, 12.55% and 3.52% respectively. The tractor driven turmeric planter was put through its place at optimal speed of 1.5 km/h. After 30 DAPS, the average plant to plant spacing was 28.68 cm. The turmeric planter had a field capacity of 0.27 ha/h.

The time needed for the planting process was 5.78 hours per hectare, with a field capacity of 64.28%. The designed planter lowered seed rate to 1027 kg/ha.

2.4 Planter Design Factors

2.4.1 Main frame

Richy *et al.* (1961) studied the main frame design importance. The main frame design is especially important in field implements because they needed to be as light as possible to reduce soil compaction, cost and power while remaining strong enough to withstand shock caused by rough ground or obstacles. Closed box and tubes section were the strongest for their arc welding and weight of connecting member allowed them to be fully utilized in bending and torsion.

Smith and Wilers (1977) provided guidelines for planter main frame fabrication. The main frame was typically constructed of mild steel angle that was reinforced at the corners and well braced. Because all other parts of the planter were supported by the main frame, the main frame had to be strong enough to keep the parts aligned and to prevent sagging. The axle was carried below the main frame, with wheel on either end. Furrow opener were suspended below the seed box, which was carried above the frame.

2.4.2 Seed metering mechanisms for planters

Kachman and Smith (1995) stated that the spacing between the seeds were affected when the mechanism failed to select the seed and drop it in the field resulting the large seed spacing and sometimes multiple seeds were selected and dropped resulting in lesser seed spacing. For achieving higher accuracy, optimization of speed of disc for regulation of seed spacing, shape of seed hole on the disc for singulation of seed, and the vacuum required to transport and drop seed should be done for a particular size of seed.

Yu-Jaingun *et al.* (1997) designed a seed metering device for precision sowing of maize cultivars. The outcome of experiment shoed that the developed seed metering mechanism can be used for precision showing of different maize cultivars without grading the seeds on basis of size.

Mathanker and Mathew (2002) investigated that performance of horizontal disc cell type and wheel type metering mechanism suitable under appropriate working condition. At various linear (peripheral) speeds, the planting mechanisms were tested. The percentage of cell

filled ranges from 128 – 143% for picker wheel type metering mechanism, as the speed ranges from 5.5 – 18.1 m/min, the physical damage ranges from 6.5 – 16 percent and missing cell ranges from 12 – 14.2%. The percentage cell fill ranges from 80 – 99% for the horizontal disc cell type metering mechanism, as the speed range from 5.1 – 21.7 m/min the physical damage range of 1-3 percent. For automatic ginger planter the picker wheel mechanism was found to be suitable with the speed of 10 – 12 m/min, for semi – automatic ginger planter horizontal disc cell mechanism was found to be suitable with the speed of 5 – 8 m/min.

Jayan and Kumar (2004) design a planter with respect to physical properties of seed. They stated that positive seed removal from the plate's cells and seeds fall by gravity in the absence of device, and variation in seeds spacing takes place because non spherical shape of peanut, they move slowly. To achieve accuracy in seed rate and uniformity in spacing it is critical to use a metering plate with cell that match the size of seeds.

Sahoo and Srivastava (2008) examined the characteristic of the soaked okra seed's seed pattern using various metering systems, including vertical rollers, horizontal plates, horizontal plates (edge drops), inclined plates, cells with the maximum seed dimension, cells with 10% more seed than the maximum seed dimension, cells with 25 percent more seed than the maximum seed dimension, and cells with 10, 14, 18 and 24 rpm cell speeds. They came to the conclusion that the average spacing of vertical rollers, horizontal plates, and horizontal plates (edge drops) with cell size 10% greater than the maximum seed dimension was near to the recommended spacing. In case of incline plate, the cell size equal to the maximum seed dimension the average spacing was near to recommended spacing. Measuring systems, cell size, and cell speed all had a significant impact on the feed quality index. With increasing speed, the quality of feed index decreased. However, when cell speed was increased to 14 rpm, only a 5% decrease in feed quality index was observed.

2.4.3 Furrow openers for planters

Verma and Dewangan (2007) reported on the mechanical considerations for the design of seed cum fertilizer drill furrow openers. They had chosen shoe, shovel, and inverted-T furrow openers for the study. Furrow opener potential was evaluated using seed emergence, draught requirements and soil disturbances. They concluded that the lowest draught requirements of 32.12 kgf for inverted – T type furrow opener, minimum soil disturbance (4 to 5 cm) and lowest clogging frequency when compare to the shoe type and shovel type furrow

opener. Inverted-T furrow openers also produced less soil disturbance than shoe and shovel furrow openers. This was due to the narrower boot width.

Marakoglu and Carman (2009) investigated the effects of cultivator share parameters on draught force and soil loosening in a soil bin. Rake angles to the horizontal of 12.5°, 17.5°, and 22.50°, working depths of 70, 110, and 150 mm, and forward speeds of 1.08, 1.55, and 2.08 m/s were among the test tool variables. The draught force was increased from 420 to 2025 N as a result of the findings. The greatest distributed area occurred at 22.5° rake, 2.08 m/s forward speed, and 150 mm depth.

Jiraporn *et al.* (2010) investigated the performance of three types of furrow openers, namely, shoe, shovel, and hoe, on a tractor-operated 10 row garlic planter in terms of clove placement depth, clove space disturbance, draught requirements, and soil disturbance extension during operation. Soil disturbance and back flow increased as the depth of operation increased. The shovel type opener had the highest germination percentage of 83.3 percent and a draught force of 1.067 kgf per opener, which was 27% greater than the hoe type opener.

Mathur and Pandey (1992) studied that the minimum specific draught for lateritic sandy clay loam soil was measured at a rake angle of 28° of the furrow openers.

Zhang and Araya (2001) reported that when the rake angle exceeded 30°, the draught force of a mould board plough increased significantly.

Abd El-Tawwab *et al.* (2007) investigated the design parameters of the furrow opener, such as the share rake angle and wing shape and angle, have a strong influence on the shape of the ridge profile. Moreover, one of the most important parameters that has a major impact on the required draught force is the share rake angle. The rake angle of the share should be 25° to the ground for better soil penetration.

2.4.4 Seed box parameters

Kual and Egbo (1985) studied the seed box or hopper in planters should have a trapezoidal, rectangular, or oval shape. The capacity of the box varies according to the size of the machines. The seed box's trapezoidal shape helps in the free flow of seed.

Klenin *et al.* (1985) studied the seed boxes, barrels and hoppers not only serves as places to store seed material, but also play an important role in the technological process by directing seed material through a feed hole to the sowing or planting device. Planter/seed boxes

were especially rectangular at the top and trapezoidal on the bottom. The slop of the side walls has been adjusted so that seed flows is not affected.

Awady and El-Said (1985) developed a simple planter whose hopper is built from iron sheeting with 45° slopping bottom.

Bosai *et al.* (1987) described some factors to consider when designing a seed box. The box must have an optimum capacity that ensures uniformity of feed seeds and continuous motion to the seeds metering mechanism, irrespective of the swing unit's direction of motion. Trapezoidal almost hexahedral and combine forms of seed hopper cross section were discovered in practice. Seed hopper's front and back walls set an angle to the base equal to the angle of friction of the sowing material with the covering surface.

2.4.5 Hitching

Srivastava (1990) studied the hitching influences the sowing rate. When the hitch was too low, the furrow openers and boot dropped seed back and upward to the ground line. The seeds were sown forward and downward to the furrow openers being hitched too high. Proper hitching not only dropped the seed rate at the correct depth, also prevent grass, dust and boot wear from clogging the furrow opener.

2.5 Performance Evaluation of Planters

Mari *et al.* (2002) evaluated the performance of potato planter. The planter was accelerated by a Fiat – 480 diesel tractor in low third gear. The tractor planter's performance was determined to be 15.73 percent moisture content, 24.04 l/h fuel consumption, 5.04 percent travel reduction, 67.47 percent field efficiency, and 0.80 ha/h field capacity.

Celik *et al.* (2007) tested four different types of seeders at three different forward speeds (3.6 km/h, 5.4 km/h, and 7.2 km/h) for seed spacing, depth uniformity, and plant emergence. No-till planter, precision vacuum planter, universal planter, and semi-automatic potato planter were the planter types. The multiple index, miss index, quality of feed index, and precision, as well as the means and standard deviations of the sample methods, were used to describe the sowing uniformity of the horizontal distribution of seeds.

Al-Gaadi and Marey (2011) evaluated the cup belt potato planter to observed effect of tuber spacing on different forward speed. They select the tuber sizes (35 – 45 mm, 45 – 55 mm and 55 – 65 mm) and forward speeds (1.8 km/h, 2.25 km/h and 3 km/h). The planter's

performance was measured in terms of coefficient of variation, mean spacing, multiple index and miss index. Better tuber spacing uniformity obtain the tuber size ranges from 35 – 45 mm. 2.25 km/h forward speed provided maximum efficiency while having no effect on seed tuber uniformity.

Dixit *et al.* (2015) evaluated the performance of tractor – mounted vertical belt type paired row potato planter for planting the potato variety Kufri Jyoti on beds. The paired row planter had a field capacity of 0.24 ha/h and a forward speed of 2.5 km/h. Missing, multiples, and seed damage were 3.3, 1.5, and 1.5 percent for paired row planters, respectively, and 5.0, 1.8, and 10.0 percent for automatic planters. A farmer's field covering approximately 117 ha was also used to evaluate the performance of a vertical belt of a paired row potato planter. The overall planting performance and potato crop stand of the belt type paired row planter were found to be satisfactory.

2.6 Cost Economics

Gupta and Verma (1990) studied on the development of a power tiller operated potato planter cum fertilizer applicator. The planter primary components included fertilizer and seed metering mechanism, two ground wheel, furrow opener, chain and sprocket and a ridge former. It could do three things at the same time: sow seeds, apply fertilizer and make ridges. Field test revealed that the machine's around 0.03 ha/h effective field capacity. On average, field efficiency was around 67 percent. When compared to traditional methods, 32 percent saving in potato planting and an 88 % reduction in labour requirements.

Shelka *et al.* (2011) studied on the adoption of bullock drawn planter through a technology transfer club. Marginal and small farmer were observed using traditional seed drills for sowing bengal gram, green gram, wheat, soybean and black gram. Due to uneven spacing and low plant population, yield gaps were observed in all major crops. Initially, only one fertilizer seed drill with a metering device was created. The yield of various crops increased by 11.21 percent on average. On an annual basis, 6-9 farmers shared the planter. The average seasonal benefits were 10522.00 Rs, and the average annual benefits on the major crops, bengal gram and soybean was Rs. 21044.00. Three women and one skilled man were saved in manpower. The cost of use was reduced by 46 percent and time was 66%, according to the results.

CHAPTER 3

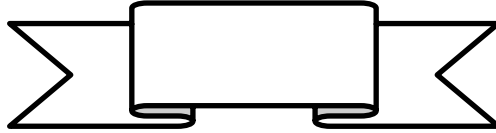

MATERIALS AND METHODS

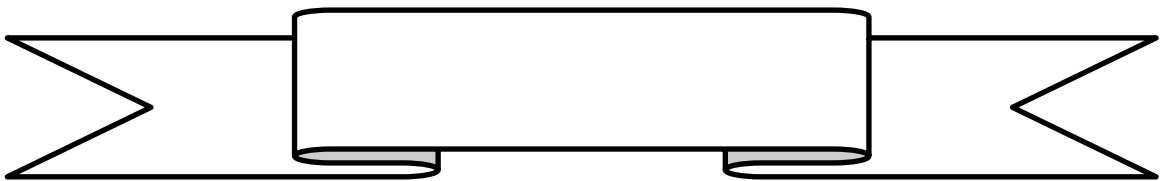

CHAPTER - III

MATERIALS AND METHODS

This chapter deals with the brief description about the methodological approach for development of two row semi-automatic turmeric planter with respect to various components and constructional detail. This also described about the crop parameter, machine parameter, soil parameter, detail of laboratory calibration and adjustment as well as actual field test and performance evaluated formula.

3.1 Crop Parameter

The following crop parameter were considered for the development of turmeric planter.

3.1.1 Physical properties

3.1.1.1 Variety of crop

The variety of crop is an important factor that affects the germination and seed rate. A locally available variety of crop was taken for the experiment. The variety of turmeric was ‘Rajendra Sonia’ and ‘Sonali’.

3.1.1.2 Weight of turmeric

Ten samples each having 10 turmeric were randomly selected from the bulk. The weight of turmeric seeds was determined by using an electronic balance with an accuracy of 0.01g and the average value was obtained. This test was carried out at Farm Machinery and Power Engineering Department.



Fig. 3.1: Weighing balance

3.1.1.3 Length, width and thickness

A digital vernier caliper was used to measure the length, width, and thickness of turmeric seeds. The length, width and thickness of 100 randomly selected turmeric seeds were

measured. When the turmeric metering disc rotates, each turmeric seed can position itself in the slots. The cell should be able to accommodate the turmeric in any position without causing external injury.



Fig. 3.2: Digital vernier calliper

3.1.1.4 Moisture content

To determine moisture content, the sample was dried in an electric oven for 24 hours at temperature 105°C and weighed with a weighing balance. The following formula was used to calculate the moisture content of the sample on percent dry basis.

$$MC \% = \frac{W_i - W_d}{W_i} \times 100$$

Where,

W_i = initial weight of the turmeric, g

W_d = dry weight of the turmeric, g

3.1.2 Frictional properties

The frictional properties of turmeric on selected surfaces, such as coefficient of friction and angle of repose, were investigated to better understand how easily the turmeric move or slide over the surfaces. The methods used to measure these properties are described in detail below.

3.1.2.1 Angle of repose

The angle of repose is the angle formed by the material when piled from a known height. The angle of repose was determined by placing a hollow cylinder on a flat surface and filling it with turmeric seeds. The cylinder was gradually raised, allowing the turmeric to flow and form a natural cone-shaped slope. The following expression was used to calculate the angle of repose.

$$\theta = \tan^{-1} \frac{H}{r}$$

Where,

θ = angle of repose, degree

H = height of the heap, mm

r = radius of the heap, mm

3.1.2.2 Coefficient of friction

The frictional experiments were conducted using a frictionless pulley mounted on a frame, loading pan, container and test surfaces. On the test surface the container was first placed, after that till the container began to slide weight were added to the loading pan. Mass of the turmeric represented the normal force and the added weight represented frictional force. The static friction co-efficient was calculated as the ratio of frictional force to normal force as,

$$\text{Coefficient of friction, } \mu = \frac{\text{frictional force (kg)}}{\text{normal force (kg)}}$$

3.2 Machine Parameter

The following parameter consider regarding the development of two row semi-automatic turmeric sowing implement (turmeric planter).

3.2.1 Considerations for the development of turmeric planter

The following consideration were made for the development of two row semi-automatic turmeric planter.

- i. The spacing between rows should be 45 cm
- ii. The spacing between plants should be at 15 – 20 cm.
- iii. The depth of placement of turmeric should be at 5 – 10 cm.
- iv. It should open the seedbed to make furrows, then drop turmeric seeds into the furrow before covering with soil.
- v. The turmeric seeds should be covered with soil and compacted after being placed in the furrow.

3.2.2 Development procedure

The procedure for the development of turmeric planter by a calculation method. First, calculate the dimension for the design of different components then fabricate the different components in the Farm Machinery and Power Engineering Department. The calculation formula, method, and dimension of different components such as seed metering mechanism, seed hopper, drive wheel, furrow opener, ridger, and frame are mentioned. Calculation is given in appendix A.

3.2.2.1 Main frame

MS square pipe was used to fabricate a rectangular main frame. It is strong enough to resist all types of loads while in operation. The planter's frame was supporting the other components and a three-point hitch assembly is fitted in the front position of the main frame. During road transportation and fieldwork, the entire frame was fully mounted on the tractor, but the planter frame is supported by the ridger bottom during planting operations. Ridger tyne was clamped on frame with the help of nut and bolt. At the back side of the frame operator seat was welded.

Due to induced draft the planter frame is subjected to torsion and bending moment. The development was based on the stress produced in the main frame.

Let, the furrow is 35 cm wide and 27 cm deep.

Soil resistance = 0.25 kg/cm^2 .

Draft per tyne = soil resistance \times width \times depth

Torque produced on frame (T) = draft \times ground clearance \times no. of tynes

The maximum bending moment at the centre

$$M = 3.5P \times 2.5x - 3Px - 2Px - Px$$

$$T_e = \sqrt{M^2 + T^2}$$

The maximum shear stress developed at the centre of frame is given by

$$\frac{S_s}{y} = \frac{T_e}{I}$$

Where,

S_s = shear stress (2000 kg/cm^2)

Y = distance at the outer most fibre from neutral axis

T_e = equivalent torque

I = moment of inertia ($d^4/12$ for square section)

$$\frac{I}{y} = \frac{T_e}{S_s}$$

$$\frac{d^4/12}{d/2} = \frac{T_e}{S_s}$$

$$\frac{d^3}{6} = \frac{T_e}{S_s}$$

3.2.2.2 Metering Mechanism

The seed metering mechanism was fabricated by mild steel flat and was powered by two wheels attached to both sides of the frame. The metering disc has ten slots and a diameter of 330 mm. The slots were evenly spaced around the metering disc's perimeter. The metering disc was horizontally rotated after being mounted over a set of bevel gears. The horizontal disc type metering unit is a metering device that requires manual feeding.

Assumption: Let us assume there is 5% slippage at the drive wheel (Bjerkan 1947).

Distance travelled per revolution of drive wheel = $\pi \times$ Diameter of drive wheel

Because of the slippage,

The actual distance travelled per revolution of drive wheel = distance travelled per revolution of drive wheel + 5% of distance travelled per revolution of drive wheel

$$\text{Gear ratio} = \frac{\text{no. of teeth on driving gear}}{\text{no. of teeth on driven gear}}$$

Recommended plant to plant spacing was 0.20 m. ((Jayashree et al., 2014))

$$\text{Number of cell per metering disc} = \frac{\text{actual distance travelled by ground wheel}}{\text{gear ratio} \times \text{rhizome spacing}}$$

Dimeter of metering disc

$$= \frac{\text{Number of cell per metering disc} \times \text{Peripheral distance between two cells}}{\pi}$$

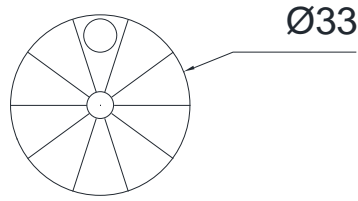

Fig. 3.3: Metering disc

3.2.2.3 Seed box or hopper

The planter's hopper was constructed with an angle bar frame and a suitable cover by a 2.2 mm thick mild steel sheet. To avoid frequent feelings during operation, the seed box should be able to store a sufficient quantity of turmeric. It was developed with the volumetric capacity, angle of repose, and bulk density of turmeric.

The length of box is given by;

$$\text{Length of seed box (L)} = \text{working width of planter} + 2b$$

Where, b = distance between the seed box wall to outer end of ridger bottom

i.e., Working width of planter = Number of rows \times Row spacing

Required development of seed box for such a capacity, that it requires n times refilling turmeric for planting 1 hectare. We know that seed rate of turmeric is 2500 kg/ha. ((Jayashree et al., 2014))

$$\text{Required volume of seed box} = \frac{\text{seed rate}}{n \times \text{bulk density}}$$

Where,

n = no. of refilling

Total volume of seed box = vol1 + vol2 + vol3 + vol4

Volume of box 1 and 2 = area \times length of seed box

$$\text{Area} = \frac{\text{Volume of seed box}}{\text{length of seed box}}$$

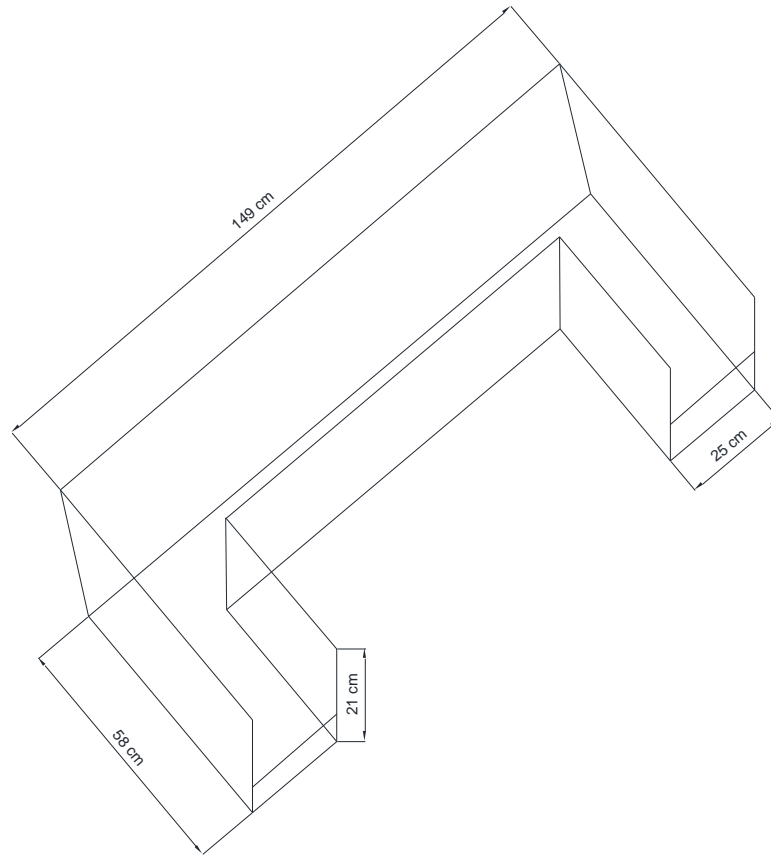

Fig. 3.4: Seed box

3.2.2.4 Seed dropping mechanism

The seed dropping mechanism was fabricated by a mild steel sheet half-cylindrical form. The turmeric seed has been placed in the cell by the operator then the turmeric has passed through a half cylindrical tube and dropped in between the two ridger.

The turmeric metering mechanism was fabricated by MS sheet of 2.2 mm thickness. The length of the seed dropping mechanism was 550 mm.

Let the turmeric drop 270 mm ahead from the hole of hopper (b) and the distance of the seed box from the ground (h) was 770 mm. θ is the angle of inclination of the turmeric seed dropping mechanism from the hopper.

$$\tan \theta = \frac{h}{b}$$

$$\theta = \tan^{-1} \frac{h}{b}$$

Hence, the turmeric seed dropping mechanism was fixed at an angle θ from the hopper.

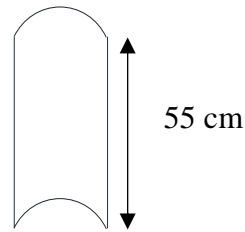

Fig. 3.5: Seed dropping mechanism

3.2.2.5 Optimization of drive wheel diameter for maintain seed to seed spacing

The drive wheel diameter is 118 cm and a gear ratio of 1.8:1 is suitable for a seed metering device which providing seed to seed spacing of 20.83 cm and 20.72 cm at the speed of 0.75 km/h and 1.00 km/h respectively, which is close to recommended seed to seed spacing of 20 cm.

Table 3.1: Different forward speed and gear ratio for optimize seed to seed spacing

S.N.	Forward speed (km/h)	Gear ratio	Drive wheel diameter (m)	Spacing between seeds (cm)
1	0.75	1.6:1	1.08	21.55
2	1	1.6:1	1.08	21.35
3	1.25	1.6:1	1.08	21.87
4	0.75	1.8:1	1.08	18.93
5	1	1.8:1	1.08	18.96
6	1.25	1.8:1	1.08	19.26
7	0.75	2.0:1	1.08	16.89
8	1	2.0:1	1.08	17.03
9	0.75	1.6:1	1.18	23.58
10	1	1.6:1	1.18	23.13
11	0.75	1.8:1	1.18	20.83
12	1	1.8:1	1.18	20.72
13	0.75	1.8:1	1.28	22.32
14	1	1.8:1	1.28	22.21

3.2.2.6 Ground wheel

The ground wheel was fabricated using high carbon steel. The ground wheel was attached to both sides of the frame and connected through the shaft. 22 lugs, 10 mm diameter and 100 mm length were welded at equidistant on the round rim of the ground wheel. The wheel had 12 spokes between the inner rim and hub, made from mild steel rods, and was welded

to the hub at the centre and inner rim of the wheel. 7 spoke between the outer rim and inner rim and were welded to the rim.

Diameter of wheel = 118 cm = 1.18 m

Peripheral distance = $\pi \times D$

Area covered in one revolution = peripheral distance \times working width of planter

No of revolutions per hectare = $\frac{10000}{\text{Area covered in one revolution}}$

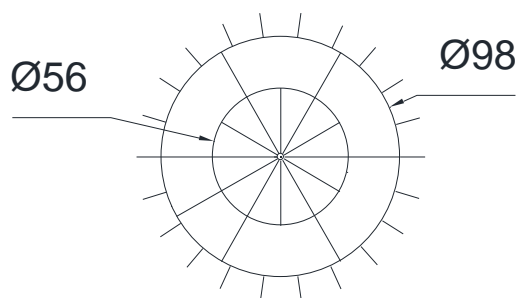

Fig. 3.7: Ground wheel

3.2.2.7 Ridger bottom

The ridger bottom was attached to the turmeric planter frame to create uniform sized ridges. As the planter was developed for two rows therefore three ridger were provided. The ridger bottom consists of a shovel, tyne, and wing. The ridger bottom was developed with adjustable curved wings shaped. At the lower end shovel was bolted with the tyne.

(a) Calculate the draft load on ridger bottom tyne/ shank

Force exerted on the ridger bottom was estimated as given below.

$$D_f = k \times w \times d$$

Where,

D_f = draft of ridger bottom, N or kg

k = specific soil resistance, N/m^2 or kg/cm^2

For light to medium soil, it would be $0.25 kg/cm^2$ to $0.5 kg/cm^2$.

w = width of the furrow opener, cm

d = depth of sowing, cm

The furrow slice cut by ridger bottom will make trapezoidal shape of furrow.

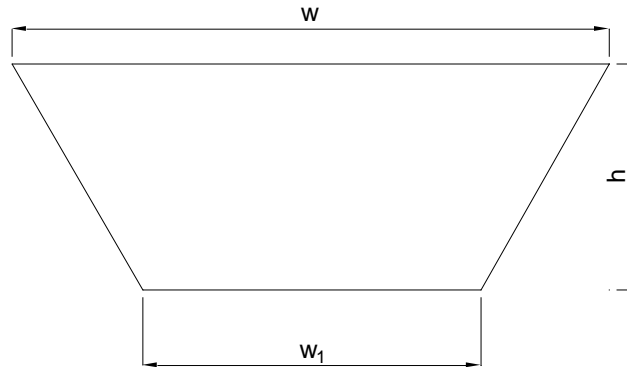

Fig. 3.8: Cross section of furrow opener

Now for proper depth of sowing

For mild steel tyne we can take factor of safety of 2

So, design draft = $D_f \times$ factor of safety

(b) Determine the bending moment in the ridger bottom tyne

Based on finding on Dubey (1985) taking

$$R = \frac{h - l \sin \alpha}{\cos \alpha}$$

Considering the ridger bottom tyne as a cantilever beam of 410 mm size fixed to the frame at one end (Krutz et. al. 1984), the maximum bending moment (M) in the tyne is given by

$$M = \text{design draft (kg)} \times \text{beam span (cm)}$$

Now selection modulus of the tyne z is calculated as under

$$\sigma_b = \frac{MC}{I} = \frac{M}{Z}$$

$$Z = \frac{I}{C}$$

Where,

σ_b = bending stress in tyne, kg/cm², we can take bending stress in mild steel flat as 1000kg/cm² (Senger, 2002)

M = bending moment in tyne, kg-cm

C = distance the point at which stress is calculated from the neutral axis

I = moment of inertia for rectangular section, cm⁴

Z = section modulus of the tyne

Also

For rectangular sections

$$Z = \frac{t \times b^2}{6}$$

The ratio between the thickness to width (t: b) = 1:3 to 1:4 can be taken

$$t: b = 1:4$$

$$b = 4t$$

Cross section of the tyne $b \times t$ mm.

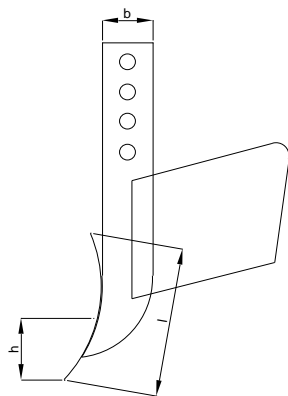

Fig. 3.9: Side view of ridger bottom

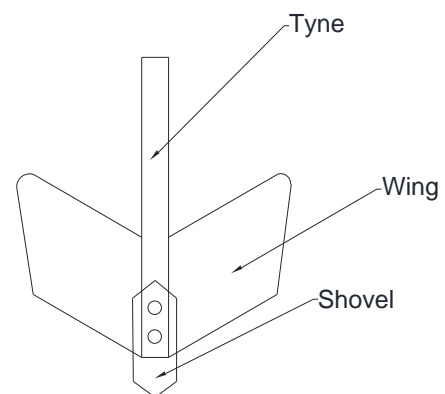

Fig. 3.10: Front view of ridger bottom

3.2.2.8 Operator Seat

The seat was fabricated by an angle iron and flat that was attached to the back side of the frame. The dimensions of the operator seat were 640 mm length and 770 mm width. Back support was provided in the seat for back support and safety. MS flats were welded between the two angle iron for sitting and back support. 5 MS flats were welded between angle iron for sitting and 4 MS flats were welded between angle iron for back support. The two operators will get together seated in the operator seat to feed the turmeric into the metering mechanism.

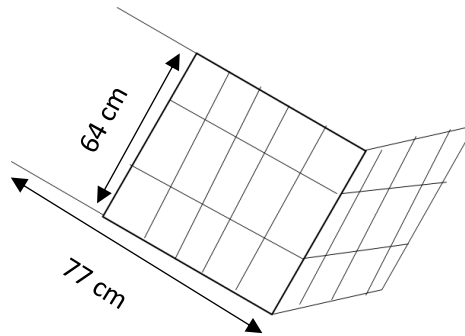

Fig. 3.11: Operator seat

3.2.2.9 Power transmission system

The power is transmitted from the ground wheel to the shaft fitted above the main frame. The shaft rested on 3 US bearings, two at the end and one at the middle of the shaft. From the shaft fitted on the main frame, the drive is transmitted to the bevel gears fitted on the shaft of the turmeric metering mechanism with a gear ratio of 1.8:1. The bevel gear fitted on the turmeric metering shaft drives the metering disc.

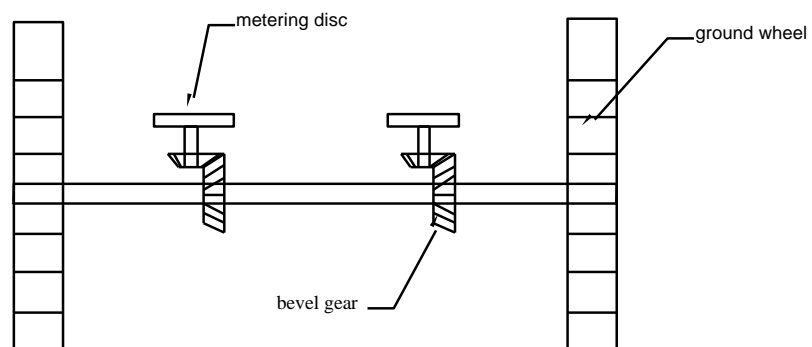

Fig. 3.12: Power transmission

3.2.2.10 Three – point linkage

The three – point linkage was provided to attached the turmeric planter to the tractor. Three – point linkage consists of one upper arm and two lower arms.

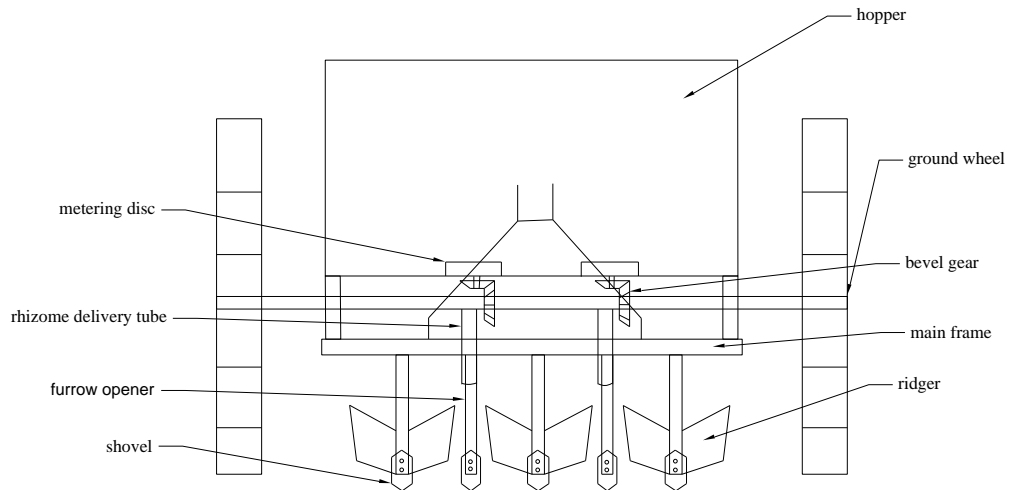

Fig. 3.13: Front view of turmeric planter



Fig. 3.14: Fabrication of turmeric planter

3.2.3 Specification of developed turmeric planter

Table 3.2: Specification of turmeric planter

S.N.	Particular	Observation
1	Main frame	
	i. Shape	Rectangular
	ii. Length (mm)	1510
	iii. Width (mm)	600

	iv. Thickness (mm)	50
	v. Material	MS square pipe
2	Hopper	
	i. Shape	Trapezoidal
	ii. Capacity (m ³)	0.109
	iii. Material	MS Sheet
3	Metring mechanism	
	i. Type of metering mechanism	Disc type
	ii. No. of turmeric metering disc	02
	iii. Diameter of metering disc (mm)	330
	iv. Width of metering disc (mm)	35
	v. No. of slot	10
	vi. Shape of slot	Conical
	vii. Material	MS flats
4	Turmeric dropping mechanism	
	i. Type	Semi cylindrical
	ii. Length (mm)	550
	iii. Diameter	100
	iv. Material	MS Sheet
5	Drive wheel	
	i. No. of drive wheel	02
	ii. Diameter (mm)	1180
	iii. Width (mm)	50
	iv. No. of lugs	22
	v. Length of lugs (mm)	100
6	Operator seat	
	i. Type	Rectangular
	ii. Length (mm)	640
	iii. Width (mm)	770
	iv. Height (mm)	270
	v. Material	MS Flats and MS angle iron
7	Furrow opener	

	i. No. of furrow opener	02
	ii. Spacing between furrow opener (mm)	450
	iii. Type	Shovel type
	iv. Material	High carbon steel
8	Ridger bottom	
	i. No. of ridger bottom	03
	ii. Spacing between ridger bottom (mm)	450
	iii. Width of ridger bottom (mm)	370 (adjustable)
	iv. Length of tyne (mm)	500
	v. Type	Wing type
	vi. Material	High carbon steel
9	Overall dimension	
	i. Length (mm)	1740
	ii. Width (mm)	1300
	iii. Height (mm)	1320
10	Colour of planter	Colourless
11	Tractor power required	35 hp or above



Fig 3.15: Developed turmeric planter

3.3 Performance Evaluation of Developed Planter

3.3.1 Soil parameter

The following soil parameter were considered during the field performance of the turmeric planter.

3.3.1.1 Type of soil

Turmeric can be sown in various soils such as ash loam, light black, red to clay loam. Well drained sandy loam or clay soils are best suited for growing turmeric. The treatment was performed on sandy loam soil.

3.3.1.2 Soil moisture content

Soil moisture content was determined by the oven dry method. The soil sample was collected up to a depth of 15 cm from the soil surface. The sample was collected from five different locations in the field. The soil moisture was calculated by the following formula.

$$\text{MC \%} = \frac{W_m - W_d}{W_d} \times 100$$

Where,

W_m = moist soil weight, g

W_d = dry soil weight, g

3.3.1.3 Soil bulk density

Bulk density is the ratio of weight of soil sample to the volume of soil. The soil sample was collected by core cutter. The bulk density depends on type of soil, type of tillage, soil texture and moisture content. Bulk density was calculated by the following formula.

$$\text{Bulk density (g/cm}^3\text{)} = \frac{\text{weight of soil sample}}{\text{volume of core cutter}}$$

3.3.2 Field Parameter

3.3.2.1 Experimental site

The experiment performed at farmer's field of village Kalyanpur district Samastipur as well as Farm Machinery and Testing Centre plot.

3.3.2.2 Layout of experimental plot

Layout of experimental plot shown in Fig. 3.16.

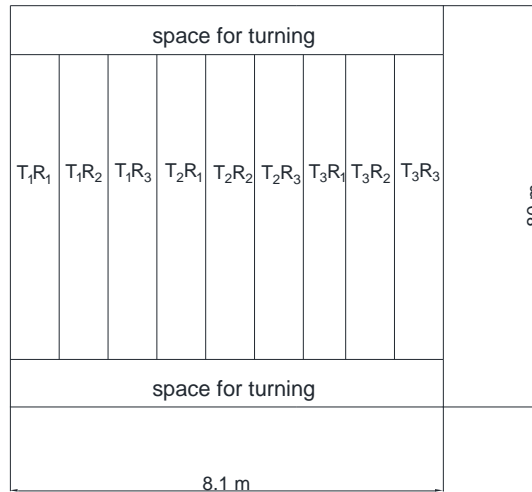

Fig. 3.16: Layout of experimental plot

3.3.2.3 Treatment

Based on speed three different treatment was performed during the field experiment and three replication was taken for each treatment. Treatments are given below.

T₁ = speed at 0.75 km/h

T₂ = speed at 1.00 km/h

T₃ = speed at 1.25 km/h

3.3.2.4 Field test

The developed tow row semi-automatic turmeric planter was tested for field performance. The tests were conducted at a farmer's field in the village Kalyanpur district Samastipur and FMTC plot. The following parameters were observed during the field test.

3.3.2.4.1 Spacing between plants

The spacing between plants (cm) was measured with measuring tape during the field trial. The spacing between plants was measured in the field at random locations.

3.3.2.4.2 Spacing between rows

The spacing between two adjacent rows (cm) was measured with a measuring tape during the field trials of the two-row turmeric planter. Row to row spacing was measured in the field at random locations.

3.3.2.4.3 Working width

The width of operation (cm) of the entire machine was measured using a measuring scale during the field trials of the two-row turmeric planter. The working width was measured in the field at random locations.

3.3.2.4.4 Depth of turmeric seed

The depth of turmeric was determined by removing the soil that had formed on the turmeric seed with a ridger and measuring the depth at which turmeric seed was placed.

3.3.2.5 Field evaluation of turmeric planter

The planter's performance indices, namely missing percentage, multiple percentage, quality of feed index and uniformity of plant to plant spacing were calculated from the measured spacing between dropped turmeric.



Fig. 3.17: Field testing of turmeric planter

3.3.2.5.1 Uniformity of turmeric spacing

To evaluate the uniformity of plant spacing, the spacing between seeds and the number of plants per hill were measured. The coefficient of uniformity was computed using the expressions below.

$$\text{coefficient of uniformity} = 100 \times \left(1 - \frac{\sum |X - \bar{X}|}{N\bar{X}} \right)$$

Where,

X = seed to seed spacing

\bar{X} = recommended seed to seed spacing

N = total no. of seed

3.3.2.5.2 Missing percentage

The missing percentage (I_{miss}) indicates how frequently the turmeric seed skips the desired spacing. When the spacing is greater than 1.5 times the recommended spacing (S) it indicates missing. That is given below,

$$I_{\text{miss}} = \frac{n_1}{N} \times 100$$

Where,

n_1 = number of spacing in the region $> 1.5 S$

N = total number of observations

3.3.2.5.3 Multiple percentage

The multiple percentage (I_{mult}) indicates that more than one turmeric seed has been dropped within the desired spacing. It is the proportion of spacing that is less than half of the recommended spacing (S). That is given below,

$$I_{\text{mult}} = \frac{n_2}{N} \times 100$$

Where,

n_2 = number of spacing in the region $< 0.5S$

N = total number of observations

3.3.2.5.4 Quality of feed index

The quality of feed index (I_{fq}) indicates that how spacing near to recommended spacing. It is the proportion of spacing that is greater than half but less than 1.5 times the recommended spacing (S). The quality of feed index is expressed mathematically as follows:

$$I_{\text{fq}} = 100 - (I_{\text{miss}} + I_{\text{mult}})$$

3.3.2.5.5 Theoretical field capacity

The theoretical field capacity was calculated by taking planter's working width and travel speed into account. The theoretical field capacity is expressed in ha/h using the formula,

$$\text{Theoretical field capacity} = \frac{\text{width of operation (m)} \times \text{speed (km/h)}}{10}$$

3.3.2.5.6 Effective field capacity

During field tests, time losses for each event, such as turmeric refilling in the planter and turning losses, were recorded. The actual field capacity was expressed in ha/h and measured using the formula,

$$\text{Effective field capacity} = \frac{\text{length of field (m)} \times \text{width of field (m)}}{10000 \times \text{time (h)}}$$

3.3.2.5.7 Field efficiency

Field efficiency was expressed as percentage and measured by using below formula,

$$\text{Field efficiency} = \frac{\text{Effective field capacity}}{\text{Theoretical field capacity}} \times 100$$

3.4 Cost of Use of Planter

Cost of sowing of turmeric planter were determined by considering fixed cost and variable cost in terms of Rs/h and Rs/ha, calculation is given in appendix G.

3.4.1 Fixed Cost

This cost can occur whether the machine is used or not. It includes depreciation, interest, taxes, insurance and housing costs.

3.4.1.1 Depreciation

Depreciation is the reduction in value of the machine with the passing of time. The following expression is used to calculate the depreciation.

$$D = \frac{C - S}{L \times H}$$

Where,

D = Depreciation cost, Rs/h

C = Initial cost of the machine, Rs

S = Salvage value of the machine

L = Life period of the machine

H = Working hours per year

I = Interest rate

3.4.1.2 Interest

An annual charge of interest was calculated on the basis of the actual rate of interest (12%). The interest is calculated by using formula

$$I = \frac{C + S}{2} \times \frac{i}{H}$$

3.4.1.3 Insurance, Taxes and Housing

Insurance, taxes and housing were estimated by taking 3% of initial cost of machine.

3.4.2 Variable cost

3.4.2.1 Repair and Maintenance

Repair and maintenance cost was calculated by taking 6% of the initial cost of the machine per year.

3.4.2.2 Fuel cost

The cost of actual fuel consumption was calculated by

Fuel cost = fuel consumed per hour × cost of fuel per hour

3.4.2.3 Lubricating cost

It is taken as 30 per cent of fuel cost.

3.4.2.4 Wages and labour charge

The labour charge was estimated under different treatment.

3.5 Economics of Use of Turmeric Planter

The cost of use of sowing by turmeric planter and by manual was compared. The cost of sowing by turmeric planter was estimated by the straight-line method of constant depreciation over the service life of the implement and the manual cost of sowing of turmeric was estimated

by the labour required for sowing it involving furrow/flatbed, putting the turmeric in the furrow and cover the turmeric with the soil.

CHAPTER 4

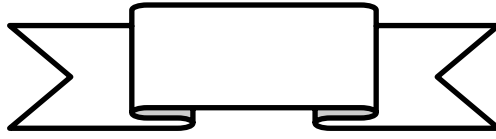

RESULTS AND DISCUSSION



CHAPTER - IV

RESULTS AND DISCUSSION

This chapter deal with as per the objective of semi-automatic two row turmeric planter was developed and evaluated in the laboratory and actual field condition. In the first phase the engineering properties of turmeric seeds were observed for development of turmeric planter. Then the developed planter was calibrated in the laboratory to observed the seed rate and the uniformity of turmeric dropping within the two furrow openers and also working function of all the components properly. Then developed planter was operated in the actual field condition at different level of speed and observed optimum actual field capacity, field efficiency, percentage missing, multiple index and cost of use was determined.

4.1 Physical Properties of Turmeric

The physical properties of turmeric i.e., weight, size, moisture content and bulk density was described in this section.

4.1.1 Weight of turmeric

The average weight of each turmeric was observed 15.70 g.

4.1.2 Moisture content

The average moisture content of turmeric was 15.65%. The weight of turmeric is dependent on moisture content greater the moisture content greater in weight.

4.1.3 Size of turmeric

Length, width, and thickness were determined with the help of a digital vernier caliper. The average length, width, and thickness were 51.22 mm, 34.16 mm, and 21.36 mm respectively.

4.1.4 Bulk density

The bulk density of turmeric is an important parameter for designing hopper capacity and for optimizing the seed rate. The bulk density of turmeric was 442.63 kg/m³.

4.2 Theoretical field capacity, effective field capacity and field efficiency

Table 4.1 shows the theoretical field capacity, effective field capacity and efficiency of the planter at three different forward speed of planter.

Table 4.1: Theoretical field capacity, effective field capacity and field efficiency of turmeric planter

S.N.	Speed (km/h)	Theoretical field capacity (ha/h)	Effective field capacity (ha/h)	Field efficiency (%)
1	0.75	0.067	0.059	88.05
2	1.00	0.090	0.077	85.55
3	1.25	0.112	0.09	80.35

Theoretical field capacity increased with an increase in speed. The theoretical field capacity was 0.067 ha/h, 0.09 ha/h, and 0.112 ha/h at the speed of 0.75 km/h, 1.00 km/h and 1.25 km/h.

Effective field capacity increased with an increase in speed. The effective field capacity was 0.059 ha/h, 0.77 ha/h and 0.09 ha/h at the speed of 0.75 km/h, 1.00 km/h and 1.25 km/h respectively.

Field efficiency decreased with an increase in speed. The field efficiency was 88.05%, 85.55% and 80.35% at the speed of 0.75 km/h, 1.00 km/h and 1.25 km/h.

4.3 Machine Evaluation in Field

The machine was evaluated in the field at seed rate 2201.31 kg/ha for assessment of uniformity in seeding, work quality, missing seed in percentage as well as multiple percentage. The economics of the machine operation was also judged by determining the cost of operation of machine with and without tractor.

4.3.1 Crop parameter

Table 4.2: Spacing and depth of placement of turmeric seeds

S.N.	Crop parameter	Observation
1	Seed to seed spacing (cm)	20.83
2	Row to row spacing (cm)	45
3	Depth of placement (cm)	8

4.3.2 Uniformity of turmeric spacing

Table 4.3: Coefficient of uniformity

S.N.	Forward speed (km/h)	Coefficient of uniformity
1	0.75	0.086
2	1.00	0.136
3	1.25	0.190

The uniformity of turmeric spacing was described by the coefficient of uniformity. The lower value of the coefficient of uniformity shows the accuracy and uniformity of the spacing of turmeric. The coefficient of uniformity increased with an increase in speed. The coefficient of uniformity was found that 0.086, 0.136 and 0.190 at the speed of 0.75 km/h, 1.00 km/h and 1.25 km/h.

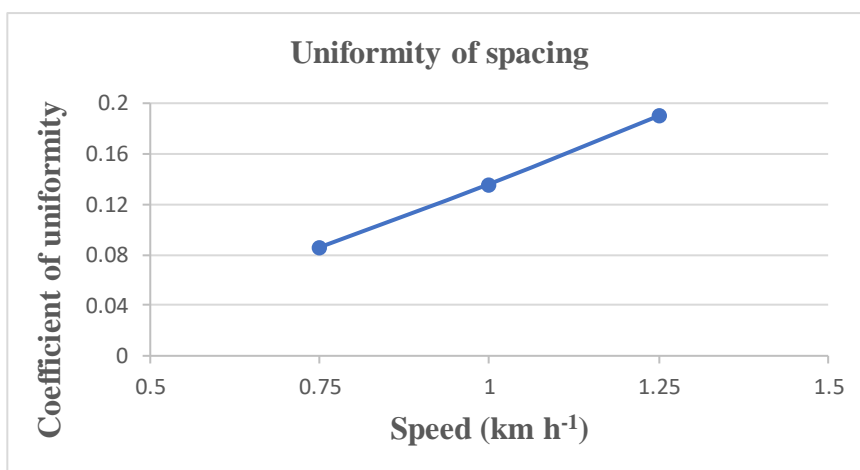

Fig. 4.1: Uniformity of spacing

4.3.3 Quality of feed index

Table 4.4: Quality of feed index

S.N.	Forward speed (km/h)	Quality of feed index (%)
1	0.75	77.63
2	1.00	72.55
3	1.25	67.34

The quality of feed index decreased with the increased in speed. It was observed that it was difficult to fill every cell with turmeric and remove multiple turmeric seeds filled in the

cell due to the speed increased. The quality of feed index was found 77.63%, 72.55% and 67.34% at the speed of 0.75 km/h, 1.00 km/h and 1.25 km/h respectively.

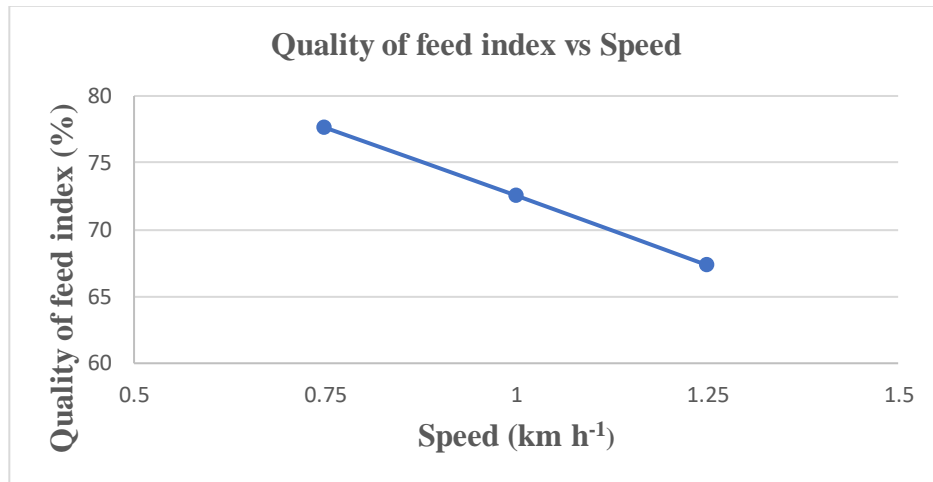

Fig. 4.2: Quality of feed index at different speed

4.3.4 Missing Percentage

Table 4.5: Missing percentage

S.N.	Forward speed (km/h)	Missing percentage (%)
1	0.75	10.35
2	1.00	12.02
3	1.25	15.43

The missing percentage slightly increased with an increase in speed. The missing percentage also depends on the labour's skill to fill the cell with turmeric seeds. The minimum missing percentage was found at speed of 0.75 km/h. The missing percentage was found 10.35%, 12.02% and 15.43% at the speed of 0.75 km/h, 1.00 km/h and 1.25 km/h respectively.

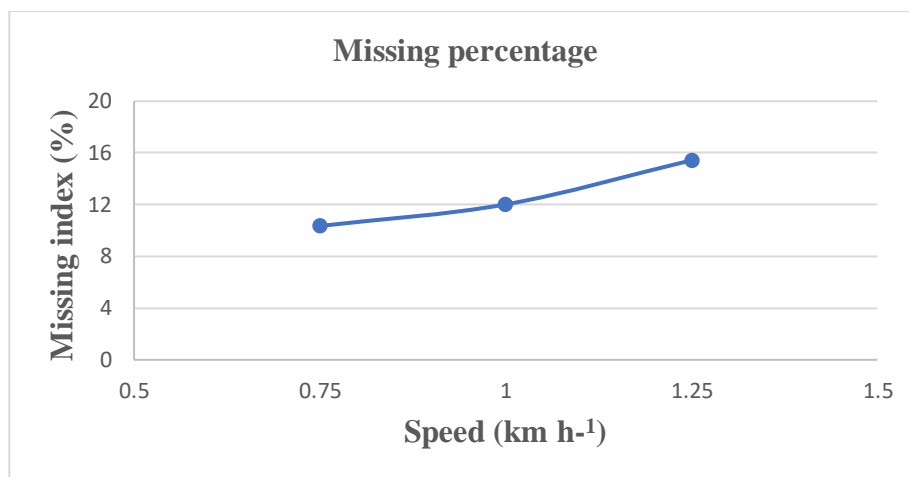

Fig. 4.3: Missing percentage at different speed

4.3.5 Multiple Percentage

Table 4.6: Multiple percentage

S.N.	Forward speed (km/h)	Multiple percentage (%)
1	0.75	12.02
2	1.00	15.43
3	1.25	17.23

Multiple percentage increased with the increase in speed. Multiple percentage depends on the labour's skill to fill the cell with turmeric. Multiple percentage was found 12.02%, 15.43%, and 17.23% at the speed of 0.75 km/h, 1.00 km/h and 1.25 km/h respectively.

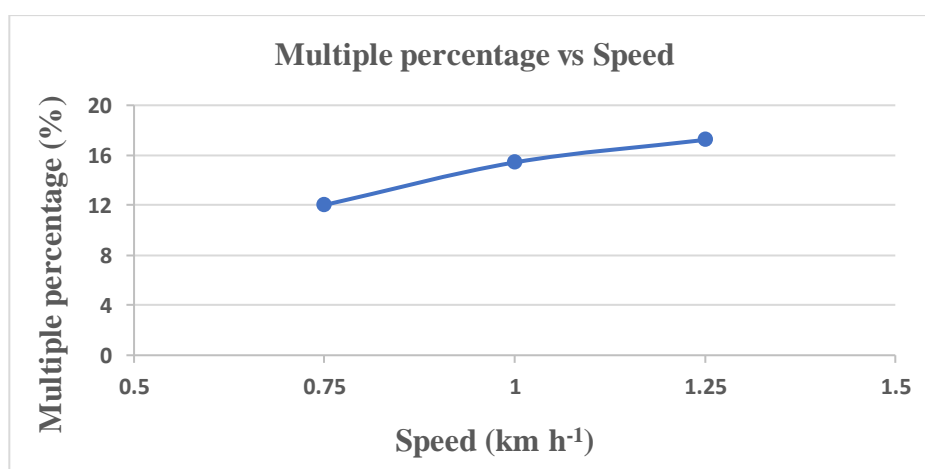

Fig. 4.4: Multiple percentage at different speed

On the basis of above treatments, we observed that the best performance of planter at the speed of 1.00 km/h among the three speeds. Because at the speed of 0.75 km/h the effective field capacity was very less whereas at the speed of 1.25 km/h missing percentage was high.

4.4 Cost Calculation

Cost of use of turmeric planter included planter and tractor fixed cost and variable cost and wages of labour required for planting. Cost of sowing by planter is given in the Table 4.7.

Table 4.7: Cost of sowing turmeric by planter

S.N.	Cost of operation	Fixed cost (Rs/h)	Variable cost (Rs/h)	Total cost (Rs/h)
1	Tractor	139.50	520.60	660.10
2	Turmeric planter	62.55	105.5	168.05
Cost of operation of sowing (Rs/h)				828.15

4.5 Comparison of Developed Planter with Manual Method Based on Cost

Cost of sowing by turmeric planter and by manual shown in appendix. The cost of sowing by turmeric planter was observed at 10755 Rs/ha and by manual 19250 Rs/ha. It was observed that the cost of sowing turmeric by planter is less as compared to manual. Cost of saving by planter for sowing turmeric was observed 8495 Rs/ha.

CHAPTER 5

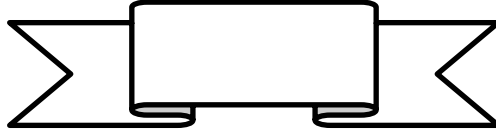

SUMMARY AND CONCLUSION

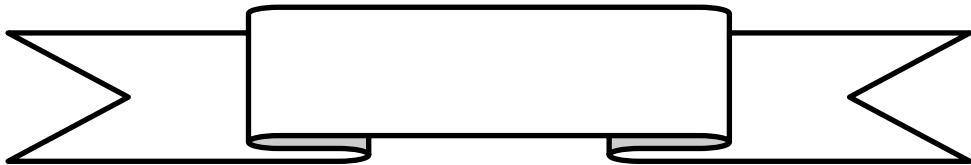

CHAPTER – V

SUMMARY AND CONCLUSION

5.1 Summary

The semi – automatic tractor operated two row turmeric planter was designed and developed at Department of Farm Machinery and Power Engineering, College of Agricultural Engineering and technology. The turmeric planter was tested in the laboratory as well as actual field condition.

The performance of turmeric sowing implement was evaluated by traditional method, machine parameter (i.e., seed rate, effective field capacity, theoretical field capacity, field efficiency, uniformity coefficient, missing percentage and multiple percentage), crop parameter (i.e., variety, weight, size, bulk density, moisture content, angle of repose and coefficient of friction), soil parameter (i.e., bulk density and moisture content), cost of operation and economic of use.

5.2 Conclusions

The semi-automatic two row turmeric planter was evaluated in the laboratory as well as actual field for its performance. Following conclusion were obtained based on the result.

1. The developed turmeric planter can be used for sowing turmeric at desired plant to plant spacing and row to row spacing.
2. The performance of seed metering mechanism was satisfactory. It provides seed rate 2201.19 kg/ha.
3. Minimum 35 hp tractor power are required for operate planter.
4. Fuel consumption for the planter was recorded 3.25 l/h.
5. Missing and multiple percentage of seeds were increased as the speed increased.
6. The best performance of the planter was observed at the speed of 1.00 km/h.
7. The cost of sowing by planter was observed 10755 Rs/ha and by manual it was 19250 Rs/ha.
8. Cost of saving by planter for sowing turmeric was observed 8495 Rs/ha.

Suggestions for future work

1. There is need of more field trails for more accurate data related to performance of turmeric planter.
2. Fabricate one more row to enhance the effective field capacity.

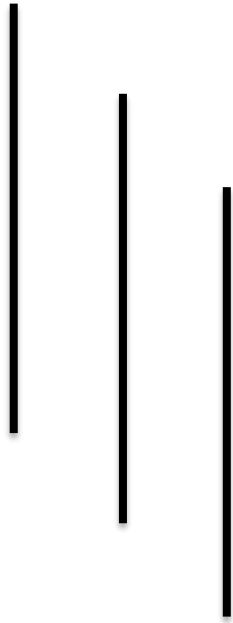
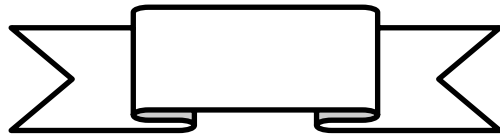

REFERENCES

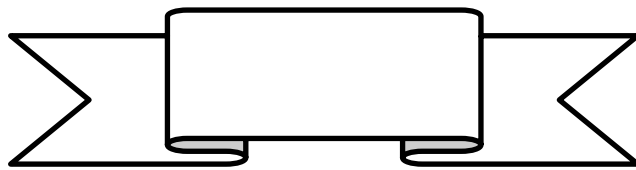

REFERENCES

- Abd El-Tawwab, I. M., Badaway, M. E. and El-Khawaga, S. 2007. Developing and performance evaluation of a locally fabricated sugar beet planter. *Misr J. Ag. Eng.* 24 (4): 648-665.
- Al-Gaadi, K. A. and Marey. 2011. Effect of forward speed and tuber characteristics on tuber spacing uniformity for a cup belt potato planter. *Middle E. J. Sci. Res.* 8(4): 753-758.
- Amzad, H. M., Ishimine Y., Akamine, H., and Motomura, K. 2005. Effects of seed rhizome size on growth and yield of turmeric. *Plant prod. Sci.* 8(1): 86-94.
- Anonymous. 2010. Report of MPUAT, Udaipur.
- Anonymous. 2014. Horticulture Statistic, Ministry of Statistics and programme implementation.
- Anonymous. 2018. Horticulture Statistic at Glance. Ministry of agriculture and Farmer's Welfare. Government of India.
- Anonymous. 2019. National Horticulture Board Report.
- Athmaselvi, K. A. and Varadharaju, N. 2002. Physical and thermal properties of turmeric rhizomes. *Madras Agric. J.* 89(10-12): 666-671.
- Awady, M. N. and El-Said, S.A. 1985. Design factors for simple grain drill feeding mechanism. *Misr. J. Ageic. Eng.* 2(2): 33-49.
- Balasubramanian, S., Mohite, A. M., Singh, K. K., ZACHARIAH, J. T., & Anand, T. (2012). Physical properties of turmeric (*Curcuma longa L.*).
- Bjerkan, J. A. 1947. The precision planting equipments. *J. Agric. Eng.* 28(4): 54-57.
- Bosai, E. S., Verniaev, O. V., Smirnov, I. I., and Sultan Shakh, E. G., 1987. Agricultural machines theory, construction and calculations. Vol. 1, Oxionian press Pvt. Ltd., New Delhi, 237-275.
- Celik, A., Ozturk, I., and Way, T. R. 2007. Effects of various planters on emergence and seed distribution uniformity of sunflower. *Appl. Eng. Agric.* 23(1): 57- 61.

- Chhattopadhyaya, S.B., Ghosh, S.K. and Mukhopadhyay, T.P. 1993. Effect of planting distance on growth and yield of turmeric. *Indian Agric.*, 37:123-126.
- Dhineshkumar, V., & Anandakumar, S. 2016. Physical and engineering properties of turmeric rhizome. *Journal of Food research and Technology*, 4(1), 30-34.
- Dixit, A., Verma, A., Singh, A., and Manes, G. S. 2015. Performance of tractor mounted vertical belt paired row potato planter. *Agric. Res. J.* 52(1): 59-61.
- Dubey, A. K. and Srivastava, N.S.L. 1985. Development of furrow openers for animal drawn seed-cum-fertilizer drill for black soils. *Proceedings of the ISAE SJC.* 1: 39-43.
- Gill, B.S., Kaur, S. and Saini, S.S. 2002. Effect of spacing and farm yard manure on growth and yield of flat and ridge planted turmeric (*Curcuma longa L.*). Extended summaries, Vol. 1, 2nd International Agronomy Congress, November 26-30, New Delhi. pp. 301-303.
- Gupta, M. L. and Verma, M. K. 1990. Development of power tiller operated potato planter-cum-fertilizer applicator. *Proceedings of the International Agricultural Engineering Conference and Exhibition, Bangkok, Thailand.* 123 – 128.
- Holiday, R. 1960. Population and crop yield. *Field Crop Abst.* 13:159-167.
- Islam, F., Karim, M. R., Shahjahan, M., Hoque, M. O., Alam, M. R., and Hossain, M.A. 2002. Study on the effect of plant spacing on the production of turmeric at farmer's field. *J. Plant Sci.* 6: 616-617.
- Jayan, P. R. and Kumar, V. J.F., 2004. Planter design in relation to the physical properties of seeds. *J. Trop. Agric.* 42 (1 & 2): 69-71.
- Jiraporn, B., Sakurai, H., and Ito, N. 2010. Design and control of metering system and furrow openers for garlic planter. *Int. Agric. Eng. J.* 19(2): 39-47.
- Kachman, S. D. and Smith, J. A. 1995. Alternative measures of accuracy in plant spacing for planters using single seed metering. *Trans. of the ASAE*, 38(2): 379- 387.
- Kandiannan, K. and Chandaragiri, K. K. 2008. Monetary and non-monetary inputs on turmeric growth, nutrient uptake, yield and economics under irrigated condition. *Indian J. Hortic.* 65(2): 209-213.

- Kandiannan, K., Sasikumar, B., Thankamani, Suseela Bhai, R., Santhosh, C. K., Eapen, J., Devasahayam, S., and John Zachariah, T. 2008. Turmeric (Extension Pamphlet). Indian Institute of Spice Sesearch. Calicut.
- Kazmeinkhah, K. 2007. Determination of energetic and ergonomic parameters of a semi-automatic sugar-beet steckling transplanter. *J. Agric. Sci. Technol.* 9: 191- 198.
- Keramat Jahromi, M., Rafiee, S., Jafari, A., Ghasemi Bousejin, M. R., Mirasheh, R., & Mohtasebi, S. S. 2008. Some physical properties of date fruit [cv. Dairi]. *International Agrophysics*, 22(3), 221-224.
- Klenin, N. I.; Popov, I. P. and Sakun, V. A. 1985. Agricultural Machines. *American Publishing Co. Pvt. Ltd.*, 129-131.
- Krutz, G., Thompson, L., and Paul, C. 1984. Design of agricultural machinery. John Wiley and Sons. Singapore. pp 245-255.
- Kual, R. N. and Egbo, C. O. 1985. Introduction to agricultural mechanization. 1st Ed. Macmillan publication Ltd. London and Basintoke. 89p.
- Kumar, B. and Gill, B. S. 2010. Growth, yield and quality of turmeric (*Curcuma longa* L.) as influenced by planting method, plant density and planting material. *J. Spices Aromat. Crops*. 19(1 & 2): 42-49.
- Marakoglu, T. and Carman, K. 2009. Effects of design parameters of a cultivator share on draft force and soil loosening in a soil bin. *J. Agron.* 8(1): 21-26.
- Mari, G. R., Memon, S. A., Leghari, N., and Brohi, A. D. 2002. Evaluation of tractor operated potato planter. *Pakistan J. Appl. Sci.* 2(9): 889-891.
- Mathanker S. K. and Mathew. M. 2002. Metering mechanisms for ginger planter. *Agric. Eng. J.* 11(1): 31-39.
- Mathur, S. M., & Pandey, K. P. 1992. Influence of system parameters on performance of reversible hoe type furrow opener for animal drawn seed and fertilizer drills. In *Proceedings of International Agricultural Engineering Conference* (Vol. 1, pp. 143-150). Asian Institute of Technology Bangkok.

- Mishra, A. K., & Singh, A. P. 2017. Evaluation of different turmeric genotypes for yield and yield attributing traits on the basis of mean performance. *International Journal of Pure & Applied Bioscience*, 5(4), 771-774.
- Mishra. A. K. and Kulkarni, S. D. 2009. Engineering properties of turmeric Rhizome (*Curcuma.Longa L*). *Agric. Eng. Today*. 33(2): 26-31.
- Philip, J. 1985. Effect of plant density on yield and yield components of turmeric. *Indian Cocoa, Arecanut and Spices Journal*, 8(4), 93-96.
- Richy, C. B.; Jacobcon, C. B. and Hall, C. W. 1961. Agricultural Engineer's Handbook. *First Edition, McGraw-Hill Book Company, New York*. 172 -186.
- Sahoo, P. K and Srivastava, A. P. 2000. Development and performance evaluation of okra planter. *J. Agric. Eng.* 37(2): 15-25.
- Sahoo, P. K and Srivastava, A. P. 2008. Seed pattern characteristics of different metering systems for soaked okra seed. *J. Agric. Eng.* 45(1): 1-6.
- Senger, S. M. 2002. Design and development of animal drawn seeder for rice cum green manure crops for biasi cultivation system. M.Tech. (Agril. Engg.) Thesis, Indira Gandhi Agricultural University. Raipur, Chhattisgarh.
- Shelke, P. P., Ingole, D. N., & Deshmukh, S. K. 2011. Success Story of Adoption of Bullock Drawn Planter through Technology Transfer Club. *Agricultural Engineering Today*, 35(4), 23-29.
- Singh, A. and Kaur, S. 2015. Evaluation of different methods of turmeric (*Curcuma longa L.*) plantation. *Int. J. Agric. Sci.* 11(1): 201-203.
- Smith, H. P. and Wilers. L. H. 1977. Farm Machinery and Equipment. *Sixth Edition, Tata McGraw-Hill Publishing Co. Ltd, New Delhi*. pp.183-210.
- Srivastava, A. C. 1990. Element of Farm Machinery, Oxford and IBH Publishing Co. Pvt. Ltd, New Delhi, 89 - 117.
- Vasuki, G. 2012. Design and development of a tractor operated Turmeric planter. Unpublished M. Tech. (Agri. Eng.) Thesis, department of farm machinery, Agricultural Engineering College and Research Institute Tamil Nadu Agricultural University, Coimbatore.

- Verma, A. K. and Dewangan, M. L. 2007. Design, development and evaluation of seed cum fertilizer drill. *AMA*. 38(2): 33-37.
- Yu-Jaingun., Zue-chuncheng. and Wang-wenlong. 1997. Experimental study on a precision maize seed metering device of the step type inner cell, *Transaction of the Chinese Society of Agricultural Engineering*, 13(4).94-99.
- Zhang, C. and Araya, K. 2001. A three-stage soil layer mixing plough for the improvement of meadow soil, Part II. Soil bin experiments. *J. Agric. Eng. Res.* 78(4): 359-367.

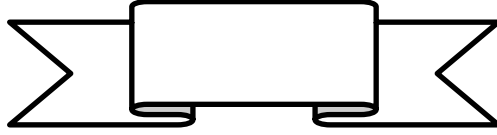

APPENDICES

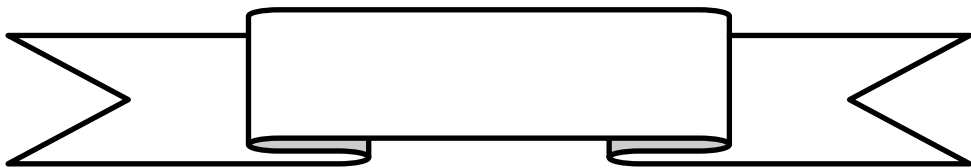

APPENDIX - A

Calculation for Turmeric Planter Components

Main frame

Draft per tyne, torque, bending moments and shear stress produced on frame was calculated as;

Let, the furrow is 35 cm wide and 27 cm deep.

Soil resistance = 0.25 kg/cm^2 .

Draft per tyne = soil resistance \times width \times depth

$$= 0.25 \times 35 \times 27$$

$$= 236.25 \text{ kg}$$

Torque produced on frame = draft \times ground clearance \times no. of tynes

$$= 236.25 \times 0.3 \times 3$$

$$= 212.625 \text{ kg-cm}$$

The maximum bending moment at the centre

$$M = 3.5P \times 2.5x - 3Px - 2Px - Px$$

$$= 8.75Px - 6Px$$

$$= 2.75Px$$

$$= 2.75 \times 236.25 \times 45$$

$$= 29235.93 \text{ kg-cm}$$

$$T_e = \sqrt{M^2 + T^2}$$

$$= \sqrt{29235.93^2 + 212.625^2}$$

$$= 29236.70 \text{ kg-cm}$$

The maximum shear stress developed at the centre of the frame is given by

$$\frac{S_s}{y} = \frac{T_e}{I}$$

$$\frac{I}{y} = \frac{T_e}{S_s}$$

Where,

S_s = Shear stress at section

Y = Distance from outermost fibre from neutral axis

T_e = Equivalent torque

I = Moment of inertia ($bd^{1/2}$ for rectangular section and for square section $b = d$)

Let assume, $S_s = 2000 \text{ kg cm}^{-2}$

$$\frac{d^4/12}{d/2} = \frac{T_e}{S_s}$$

$$\frac{d^3}{6} = \frac{29236.70}{2000}$$

$$d^3 = 87.71$$

$$d = 4.43 \text{ cm} \approx 4.5 \text{ cm}$$

So, size of tool bar was $4.5 \times 4.5 \text{ cm}$.

Metering disc

The selected diameter of ground wheel was 1180 mm.

The slippage of the ground wheel was assumed as one third of recommended slippage of 15% (Bjerkan 1947).

$$\text{Slippage of ground wheel} = \frac{1}{3} \times 15 = 5\%$$

Distance travelled per revolution of ground wheel = $\pi \times \text{Diameter of ground wheel}$

$$= \pi \times 1.18 \text{ m}$$

$$= 3.705 \text{ m}$$

Because of the slippage,

The actual distance travelled by per revolution of ground wheel

$$= 3.705 + (3.705 \times 0.05)$$

$$= 3.89 \text{ m}$$

$$\text{Gear ratio} = \frac{\text{no. of teeth on driving gear}}{\text{no. of teeth on driven gear}} = \frac{18}{10}$$

$$= 1.8:1$$

Recommended plant to plant spacing was 0.20 m.

$$\text{Number of cell per metering disc} = \frac{\text{actual distance travelled by ground wheel}}{\text{gear ratio} \times \text{plant spacing}}$$

$$= \frac{3.89}{1.8 \times 0.20}$$

$$= 10.89$$

Peripheral distance between two cells should be 10.35 cm.

$$\text{Dimeter of metering disc} = \frac{10 \times 10.35}{\pi}$$

$$= 32.94$$

$$\approx 33 \text{ cm}$$

Ground wheel

$$\text{Diameter of wheel} = 118 \text{ cm} = 1.18 \text{ m}$$

$$\text{Peripheral distance} = \pi \times D = 3.14 \times 1.18 = 3.705 \text{ m}$$

$$\text{Area covered in one revolution} = \text{peripheral distance} \times \text{working width of planter}$$

$$= 3.07 \times 0.90$$

$$= 3.33 \text{ m}^2$$

$$\text{No of revolution per hectare} = \frac{10000}{3.33}$$

$$= 3003 \text{ rev/ha}$$

Seed box or hopper

The seed box made of MS sheet. The length of box is given by

Length of seed box (L) = planter working width + 2b

Where, b = distance between the seed box wall to the outer end of ridger bottom

So, working width of planter = Number of ridger bottom × Row spacing

$$= 3 \times 45$$

$$= 135 \text{ cm}$$

Therefore, length of the rhizome box = 135 + 2(7)

$$= 149 \text{ cm}$$

We know that seed rate of turmeric is 2500 kg/ha and bulk density is 452.89 kg/m³.

$$\text{Required volume of seed box} = \frac{\text{seed rate}}{n \times \text{bulk density}}$$

Where,

n = no. of refilling per hectare (assume 40)

$$\begin{aligned} \text{Required volume of seed box} &= \frac{2500}{40 \times 452.89} \\ &= 0.138 \text{ m}^3 \end{aligned}$$

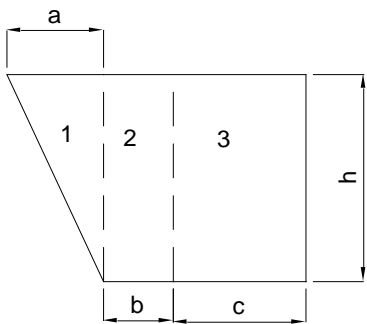

Fig. (a): Side view of seed box

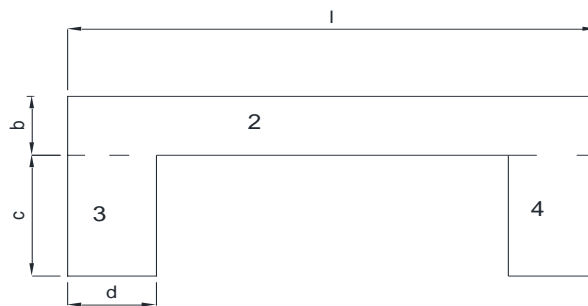

Fig. (b): Top view of seed box

Total volume of seed box = vol1 + vol2 + vol3 + vol4

Let the volume of box 1 and 2 = 0.096 m³

And volume of box 3 and 4 = total vol. – vol. of 1 and 2

$$= 0.138 - 0.096$$

$$= 0.042 \text{ m}^3$$

Therefore, volume of box 3 = $\frac{0.042}{2}$

$$= 0.021 \text{ m}^3$$

Volume of box 1 and 2 = area \times length of seed box

$$\text{area} = \frac{\text{Volume of seed box}}{\text{length of seed box}}$$

$$= \frac{0.096}{1.49}$$

$$= 0.064 \text{ m}^2$$

Total area = area1 + area2

$$\text{Area1} = \frac{1}{2} \times a \times h$$

$$= \frac{1}{2} \times hcot\theta \times h$$

$$\text{Area2} = b \times h$$

From Fig (a) $\tan\theta = \frac{h}{a}$

So, $a = hcot\theta$

$$\text{Total area} = \frac{1}{2} \times hcot\theta \times h + b \times h$$

Now, assume the value of $h = 0.21 \text{ m}$ and take the value of $\theta = 74^\circ$

$$0.064 = \frac{1}{2} \times 0.21cot74 \times 0.21 + b \times 0.21$$

$$b = 0.27\text{m}$$

therefore, $a = 0.21 \times cot74 = 0.06\text{m}$

$$\text{volume of box 3} = 0.026 \text{ m}^3$$

$$\text{area of box 3} = \frac{\text{volume}}{\text{length}}$$

$$= \frac{0.021}{0.25}$$

$$= 0.084 \text{ m}^2$$

Area of box 3 = $c \times h$

$$0.084 = c \times 0.21$$

$$c = \frac{0.084}{0.021}$$

$$c = 0.40 \text{ m.}$$

Seed dropping mechanism

The seed tube was made of MS sheet. The length of seed tube was 550 mm.

Let the turmeric seed dropped 270 mm ahead from the hole (b) and the height of seed box from the ground (h) was 720 mm. θ is angle of the seed dropping mechanism.

$$\tan \theta = \frac{h}{b}$$

$$\tan \theta = \frac{72}{27}$$

$$\tan \theta = 2.66$$

$$\theta = \tan^{-1}2.66$$

$$\theta = 69.44^\circ$$

hence the seed tube was fixed 69.44° from the box.

Ridger bottom

(a) Calculate the draft load on ridger bottom tyne/ shank

Force exerted on the ridger bottom was estimated as given below.

$$D_f = k \times w \times h$$

Where,

D_f = Draft on ridger bottom, kg or N

K_s = Specific soil resistance, kg cm^{-2} or N cm^{-2}

W = Width of furrow opener, cm

h = depth of operation, cm

For light to medium soil, specific resistance would be 0.25 kg/cm^2 to 0.5 kg/cm^2 .

The furrow slice cut by ridger bottom will make trapezoidal type of furrow.

Now for proper depth of sowing

Assume $w = 37 \text{ cm}$

$w_1 = 35 \text{ cm}$

$h = 27 \text{ cm}$

$k = 0.375 \text{ kg/cm}^2$

Therefore,

$$D_f = \frac{0.375 \times (37 + 35) \times 27}{2}$$
$$= 364.5 \text{ kgf}$$

Now for mild steel tyne we can take factor of safety of 2

So, design draft = $D_f \times$ factor of safety

$$= 364.5 \times 2$$

$$= 729 \text{ kgf}$$

(b) Determine the bending moment in the ridger bottom tyne

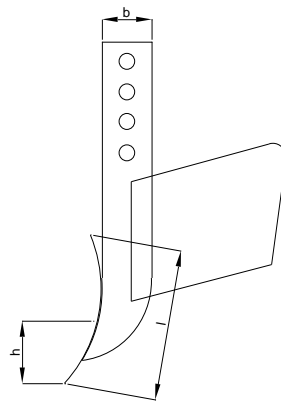

Fig. Side view of ridger bottom

Based on finding on Dubey (1985) taking

$$h = 140 \text{ mm}$$

$$l = 110 \text{ mm}$$

$$\alpha = 25^\circ$$

putting these values in following equation,

$$R = \frac{h - l \sin \alpha}{\cos \alpha}$$

$$R = 103.2 \text{ mm}$$

Considering the ridger bottom tyne as a cantilever beam of 410 mm size fixed to the frame at one end (Krutz et. al. 1984), the maximum bending moment (M) in the tyne is given by

$$\begin{aligned} M &= \text{design draft (kg)} \times \text{beam spam (cm)} \\ &= 729 \times 41 \\ &= 29889 \text{ kg-cm} \end{aligned}$$

Now selection modulus of the tyne z is calculated as under

$$\begin{aligned} \sigma_b &= \frac{MC}{I} = \frac{M}{Z} \\ Z &= \frac{I}{C} \end{aligned}$$

Also

For rectangular sections

$$Z = \frac{t \times b^2}{6}$$

The ratio between thickness to width (t: b) = 1:3 to 1:4 can be taken

$$t : b = 1:4$$

$$b = 4t$$

$$Z = \frac{t \times 4t^2}{6}$$

$$Z = \frac{16t^3}{6}$$

$$Z = \frac{M}{\sigma_b} = \frac{29889}{1000}$$

$$= 29.889$$

$$29.889 = \frac{16t^3}{6}$$

$$t^3 = 11.20$$

$$t = 2.23 \text{ cm} = 22.3 \text{ mm}$$

$$b = 22.3 \times 4$$

$$= 89.49 \text{ mm}$$

Cross section of the tyne 22.3 × 89.49 mm.

APPENDIX - B

Table B1: Moisture content of turmeric

S.N.	Initial weight of turmeric (g)	Dry weight of turmeric (g)	Moisture content (%)	Average
1	261.2	230.1	13.57	
2	173.4	147.3	17.71	15.65%
3	166.2	143.6	15.73	

Table B2: Bulk density of turmeric

Replication	1	2	3	Avg.
Bulk density (kg m ⁻³)	480.66	402.57	444.66	442.63

Table B3: Size of turmeric

S.N.	Length(mm)	Width(mm)	Thickness(mm)
1	62.26	48.59	22.34
2	58.77	33.46	25.81
3	49.27	34.66	21.81
4	60.01	34.44	20.90
5	34.87	22.05	16.54
6	57.92	41.25	29.22
7	50.38	36.07	21.68
8	42.95	31.81	19.85
9	44.16	25.86	15.02
10	52.0	33.46	20.45
Avg.	51.22	34.16	21.36

Table B4: Coefficient of friction

Material	Aluminium	Mild steel	Stainless steel
Coefficient of friction	0.57	0.72	0.53

APPENDIX - C

Table C1: Moisture content of soil

S.N.	Weight of wet soil (g)	Weight of dry soil (g)	Moisture content (%)	Average
1	142.95	123.46	15.78	
2	168.57	145.76	15.65	15.78%
3	159.54	137.62	15.93	

Table C2: Bulk density of soil

S.N.	Weight of soil sample (g)	Volume of core cutter (cm ³)	Bulk density (g/cm ³)	Average (g/cm ³)
1	155.74	100	1.55	
2	178.57	100	1.78	
3	164.68	100	1.64	1.62
4	149.95	100	1.49	
5	167.48	100	1.67	

APPENDIX - D

Calibration of turmeric planter

D = diameter of ground wheel

$$= 1.18 \text{ m}$$

L = length of strip covers by one revolution of ground wheel

$$L = \pi \times D$$

$$= 3.70 \text{ m}$$

No. of furrow opener = 2

Spacing between furrow opener = 0.45 m

Area covered in one revolution of ground wheel = $2 \times 0.45 \times 3.70$

$$= 3.33 \text{ m}^2$$

No. of revolution required to cover 1 ha of field = $\frac{10000}{3.33}$

$$= 3003$$

Turmeric rhizome collected in 10 revolution of ground wheel = 7.33 kg

Turmeric rhizome required in 3003 revolution of ground wheel = $\frac{7.33}{10} \times 3003$

$$= 2201.19 \text{ kg}$$

Therefore, seed rate of planter = 2201.19 kg/ha

No. of turmeric rhizome collected in 10 revolution of ground wheel = 190

Distance cover by planter in 10 revolution of ground wheel = 10×3.70

$$= 37.00 \text{ m}$$

Spacing between rhizome = $\frac{37}{190}$

$$= 19.47 \text{ cm}$$

APPENDIX – E

Determination of number of missing and multiples

Speed = 0.75 km/h

S.N.	Particular	Observation		
		Replication 1	Replication 2	Replication 3
1	Length of run (m)	5	5	5
2	Theoretical no. of seed drop	25	25	25
3	Actual no. of seed drop	22	23	23
4	Number of missing	3	2	2
5	Number of multiple	3	3	2
6	Missing percentage (%)	13.63	8.69	8.69
7	Multiple percentage (%)	13.63	13.63	8.69

Speed = 1.00 km/h

S.N.	Particular	Observation		
		Replication 1	Replication 2	Replication 3
1	Length of run (m)	5	5	5
2	Theoretical no. of seed drop	25	25	25
3	Actual no. of seed drop	22	23	22
4	Number of missing	3	2	3
5	Number of multiple	3	3	4
6	Missing percentage (%)	13.63	8.69	13.63
7	Multiple percentage (%)	13.63	13.63	19.04

Speed = 1.25 km/h

S.N.	Particular	Observation		
		Replication 1	Replication 2	Replication 3
1	Length of run (m)	5	5	5
2	Theoretical no. of seed drop	25	25	25
3	Actual no. of seed drop	22	21	22
4	Number of missing	3	4	3
5	Number of multiple	3	4	4
6	Missing percentage (%)	13.63	19.04	13.63
7	Multiple percentage (%)	13.63	19.04	19.04

APPENDIX – F

At the speed of 0.75 km/h

$$\begin{aligned}\text{Theoretical field capacity} &= \frac{\text{width of operation (m)} \times \text{speed(km/h)}}{10} \\ &= \frac{0.90 \times 0.75}{10} \\ &= 0.067 \text{ ha/h}\end{aligned}$$

$$\begin{aligned}\text{Actual field capacity} &= \frac{\text{length of field (m)} \times \text{width of field(m)}}{10000 \times \text{time (h)}} \\ &= \frac{80 \times 2.70}{10000 \times 0.37} \\ &= 0.059 \text{ ha/h}\end{aligned}$$

$$\begin{aligned}\text{Field efficiency} &= \frac{\text{Actual field capacity}}{\text{Theoretical field capacity}} \\ &= \frac{0.059}{0.067} \\ &= 88.05\%\end{aligned}$$

At the speed of 1.00 km/h

$$\begin{aligned}\text{Theoretical field capacity} &= \frac{\text{width of operation (m)} \times \text{speed(km/h)}}{10} \\ &= \frac{0.90 \times 1.00}{10} \\ &= 0.09 \text{ ha/h}\end{aligned}$$

$$\begin{aligned}\text{Actual field capacity} &= \frac{\text{length of field (m)} \times \text{width of field(m)}}{10000 \times \text{time (h)}} \\ &= \frac{80 \times 2.70}{10000 \times 0.28} \\ &= 0.077 \text{ ha/h}\end{aligned}$$

$$\begin{aligned}\text{Field efficiency} &= \frac{\text{Actual field capacity}}{\text{Theoretical field capacity}} \\ &= \frac{0.077}{0.09} \\ &= 85.55\%\end{aligned}$$

At the speed of 1.25 km/h

$$\begin{aligned}\text{Theoretical field capacity} &= \frac{\text{width of operation (m)} \times \text{speed(km/h)}}{10} \\ &= \frac{0.90 \times 1.25}{10} \\ &= 0.112 \text{ ha/h}\end{aligned}$$

$$\begin{aligned}\text{Actual field capacity} &= \frac{\text{length of field (m)} \times \text{width of field(m)}}{10000 \times \text{time (h)}} \\ &= \frac{80 \times 2.70}{10000 \times 0.24} \\ &= 0.09 \text{ ha/h}\end{aligned}$$

$$\begin{aligned}\text{Field efficiency} &= \frac{\text{Actual field capacity}}{\text{Theoretical field capacity}} \\ &= \frac{0.09}{0.112} \\ &= 80.35\%\end{aligned}$$

APPENDIX - G

Table G1: Cost of use of turmeric planter

S.N.	Particulars	Tractor	Planter
I	Fixed cost		
1	Unit cost of machine, Rs	750000	60000
2	Life of the machine, Y	10	8
3	Annual use, h	1000	200
4	Deprecation, Rs/h	67.50	33.75
5	Annual interest @ 12% per annum, Rs/h	49.50	19.80
6	Housing cost, insurance and taxes @ 3% of the unit cost of the machine	22.50	9.00
A.	Total fixed cost, Rs/h (4+5+6)	184.50	80.55
II	Variable cost		
7	Repair and maintenance cost per hour is @6% of initial cost	45.00	18.00
8	Fuel cost @Rs 96 per litter, Rs/h	312.00	
9	Lubricating cost @ 30% of fuel cost, Rs/h	93.60	
10	Wages of worker Rs 600/day, for tractor Rs 350/day for planter, Rs/h	75.00	87.5
B.	Variable cost, Rs/h (sum 7 to 10)	520.60	105.5
Total	cost of operation Rs/h (A+B)	660.1	168.05

1. Cost of operation of tractor

A. Fixed Cost

1 Depreciation

$$D = \frac{C - S}{L \times H}$$

Where,

D = Depreciation cost, average per year;

C = Unit cost of the machine;

S = Residual value of the machine

L = Useful life of the machine in years;

H = Working hours per year; and

I = Interest rate, %

$$D = \frac{750000 - 75000}{10 \times 1000}$$

$$D = 67.50 \text{ Rs/h}$$

2 Interest

$$I = \frac{C + S}{2} \times \frac{i}{H}$$

$$I = \frac{750000 + 75000}{2} \times \frac{0.12}{1000}$$

$$I = 49.50 \text{ Rs/h}$$

3 Insurance, Taxes and Housing

$$\text{Housing} = \frac{1\% \text{ initial cost of machine}}{\text{annual use}}$$

$$\text{Housing} = \frac{0.03 \times 750000}{1000}$$

$$\text{Housing} = 7.50 \text{ Rs/h}$$

$$\text{Insurance} = 7.50 \text{ Rs/h}$$

$$\text{Taxes} = 7.50 \text{ Rs/h}$$

B. Variable Cost

1 Repair and Maintenance

$$\text{R \& M} = \frac{6\% \text{ of initial cost of machine}}{\text{annual use}}$$

$$\text{R \& M} = \frac{0.06 \times 750000}{1000}$$

$$\text{R \& M} = 45 \text{ Rs/h}$$

2 Fuel consumption

- In one hour 3.25-liter diesel consumed and prevailing diesel price was 96 Rs/l.
- Therefore, fuel cost of tractor was 312.00 Rs/h.

3 Lubricating Cost

Lubricating cost = 30% of fuel cost

Lubricating cost = 0.30×312

Lubricating cost = 93.60 Rs/h

4 Operator Charges

- Operator cost 600 Rs per day of 8 hours.
- Therefore, it is 75.00 Rs/h.

Total tractor cost = fixed cost + variable cost
= 705.10 Rs/h

2. Cost of operation of turmeric planter

A. Fixed Cost

1 Depreciation

$$D = \frac{C - S}{L \times H}$$

$$D = \frac{60000 - 6000}{8 \times 200}$$

$$D = 33.75 \text{ Rs/h}$$

2 Interest

$$I = \frac{C + S}{2} \times \frac{i}{H}$$

$$I = \frac{60000 + 6000}{2} \times \frac{0.12}{1000}$$

$$I = 19.80 \text{ Rs/h}$$

3 Insurance, Taxes and Housing

$$\text{Housing} = \frac{1\% \text{ intial cost of machine}}{\text{anual use}}$$

$$\text{Housing} = \frac{0.01 \times 60000}{200}$$

Housing = 3.00 Rs/h

Insurance = 3.00 Rs/h

Taxes = 3.00 Rs/h

B. Variable Cost

1. Repair and Maintenance

$$\text{R \& M} = \frac{6\% \text{ of intial cost of machine}}{\text{anual use}}$$

$$\text{R \& M} = \frac{0.06 \times 60000}{200}$$

R & M = 18 Rs/h

2. Labour wages

- Labour wages 350 Rs per day of 8 hours and 2 labour required.
- Therefore, it is 87.50 Rs/h.

Total turmeric planter cost = fixed cost + variable cost

$$= 186.05 \text{ Rs/h}$$

Total cost of sowing = tractor cost + planter cost

$$= 660.10 + 168.05$$

$$= 828.15 \text{ Rs/h}$$

3. Cost of sowing by manual

Time required for sowing 1 ha of land = 55 man-days

Wages of workers = 350 Rs/day, for 8 hours

Cost of sowing for 1 ha field = 55 × 350

$$= 19250 \text{ Rs/ha}$$

Table G2: Cost of sowing by planter and manual

S.N.	Particular	Observation
A	Cost of sowing by planter	
1	Cost of operation (Rs/h)	828.15
2	Effective field capacity of planter (ha/h)	0.077
3	Cost of sowing by planter for 1 ha of field (Rs/ha)	10755
B	Cost of sowing by manual	
4	Man power required (man-day)	55
5	Wages of worker (Rs/day)	350
6	Manual cost of sowing (Rs/ha)	19250



Development of tractor operated semi-automatic two row turmeric planter

ORIGINALITY REPORT

16%
SIMILARITY INDEX

15%
INTERNET SOURCES

6%
PUBLICATIONS

4%
STUDENT PAPERS

PRIMARY SOURCES

1	krishikosh.egranth.ac.in Internet Source	6%
2	www.ijcmas.com Internet Source	2%
3	researchjournal.co.in Internet Source	2%
4	etd.astu.edu.et Internet Source	1%
5	www.gbpuat.res.in Internet Source	1%
6	www.agrojournal.org Internet Source	<1%
7	Submitted to Indira Gandhi Agricultural University Student Paper	<1%
8	www.agrimoon.com Internet Source	<1%

सहायक पुस्तकालयाध्यक्ष
Asstt. Librarian
विश्वविद्यालय पुस्तकालय
University Library
पुस्तकालय, पृष्ठा (समस्तीपुर)
Pusa (Samastipur)

Mojan Kumar
Asstt. Librarian
Date: 15/09/2022

for
University Librarian
DR. R.P.C.A.U, PUSA
Samastipur (Bihar)-848125