

EFFECT OF FERTIGATION WITH NORMAL AND WATER SOLUBLE
FERTILIZERS COMPARED TO DRIP AND FURROW SYSTEMS IN
CAPSICUM-MAIZE-SUNFLOWER CROPPING SEQUENCE

A.P. MURALIDHAR

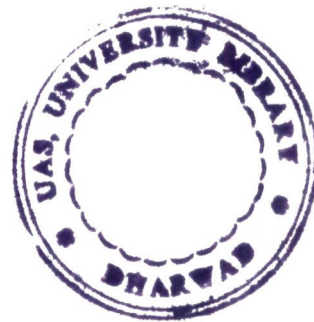

DEPARTMENT OF AGRONOMY
UNIVERSITY OF AGRICULTURAL SCIENCES
BANGALORE
1998

EFFECT OF FERTIGATION WITH NORMAL AND WATER SOLUBLE
FERTILIZERS COMPARED TO DRIP AND FURROW SYSTEMS IN
CAPSICUM-MAIZE-SUNFLOWER CROPPING SEQUENCE

A.P.MURALIDHAR



Thesis submitted to the
University of Agricultural Sciences, Bangalore
In partial fulfilment of the requirements
For the award of the Degree of

Doctor of Philosophy

in

AGRONOMY

BANGALORE

JANUARY, 1998

U. A. S.
University Library
DHARWAD.

Acc. No. **TH-5845**

Department of Agronomy
University of Agricultural Sciences
Bangalore

CERTIFICATE

This is to certify that the thesis entitled "**EFFECT OF FERTIGATION WITH NORMAL AND WATERSOLUBLE FERTILIZERS COMPARED TO DRIP AND FURROW SYSTEMS IN CAPSICUM – MAIZE – SUNFLOWER CROPPING SEQUENCE**" submitted in partial fulfilment of the requirements for the degree of DOCTOR OF PHILOSOPHY in Agronomy to the University of Agricultural Sciences, Bangalore, is a record of research work carried out by Mr.A.P MURALIDHAR, under my guidance and supervision and that no part of the thesis has been submitted for the award of any other degree, diploma, associateship, fellowship or other similar titles.

BANGALORE
JANUARY, 1998

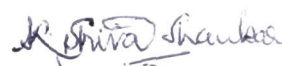



(K. SHIVASHANKAR)
Professor and Head,
Department of Forestry and
Chairman, Agricultural Museum, Hebbal.

APPROVED BY :

CHAIRMAN :  28.2.98
(K. Shivashankar)

MEMBERS :

1.  28/2/98
(Gururaj Hunsigi)

2. 
(M.A. Singlachar)

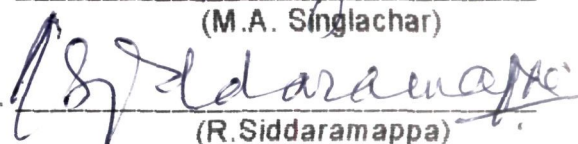
3. 
(R. Siddaramappa)

4. _____
(M.M. Khan)

ACKNOWLEDGEMENT

I am deeply indebted to Dr.K. Shvashankar, M.Sc. (Ag), M.S., D.Sc.(Leuven), FISA. Professor and Head, Department of Forestry, Chairman, Agricultural Sciences Museum and Chairman of my advisory committee for his keen interest, helpful discussions and encouragement at all times, and for the invaluable guidance both during field work and during the preparation of thesis. It was indeed a great source of inspiration to be associated with him and I am thankful for all his kindness.

I am equally grateful to Dr.M.A.Singlchar, Associate Director of Research(HQ), Dr. Gururaj Hunsgi, Professor and Head, Department of Agronomy, Dr.R.Siddaramappa, Professor and Head, Department of Soil Science and Agricultural Chemistry and Dr.M.M.Khan, Professor and Head, Division of Horticulture, members of advisory committee for their valuable suggestions during the planning of experiments, execution and critical persual of manuscript, keen interest and encouragement.

I record my sincere thanks to my friends especially H.R.Shvakumar, Sivakumaran and H.K.Basavaraju for all the help rendered during my study and stay.

On this occasion, I can never forget the infinite affection and incessant encouragement rendered by my brother -A.P.Srikanth and uncle -R.A.Rajashekar, aunt -M.A. Alameku and cousin -R.A. Lakshmi throughout my study period.

The financial help rendered by the KEMIRA-AGRO/HORT, Helsinki, Finland, in the form of Senior Research Fellowship during my study is gratefully acknowledged.

It is a pleasure to thank Smt. Chandrika for her timely computer services.

Above all, I wish to express my sincere respects and regards to my parents who gave encouragement when it was most needed. But for their sacrifice, co-operation and kindness this work would not have seen the light of the day.

Bangalore
January 19, 1998.

(A.P. MURALIDHAR)

CONTENTS

<u>CHAPTER NO.</u>	<u>TITLE</u>	<u>PAGE NO</u>
I	INTRODUCTION	1
II	REVIEW OF LITERATURE	4
III	MATERIAL AND METHODS	24
IV	EXPERIMENTAL RESULTS	36
V	DISCUSSION	140
VI	SUMMARY	165
VII	REFERENCES	170

LIST OF TABLES

<u>TABLE NO.</u>	<u>TITLE</u>	<u>PAGE NO.</u>
3.1	Physical and chemical properties of soil of the experimental site, Main Research Station, Hebbal, Bangalore	25
3.2	Meteorological data indicating monthly normal (1980-90) and actual (1994-95 and 1996-97) weather parameters during crop growth period at Main Research Station, Hebbal, Bangalore	26
3.3	Details of experiment	28
3.4	Quantity of irrigation water applied during the experimental period	31
3.5	Fertilizer application schedule	31
3.6	Method of recording observations on different parameters	33-35
4.1	Plant height in capsicum as influenced by methods of irrigation, levels and sources of fertilizers during 1994 and 1996	37
4.2	Leaf area in capsicum as influenced by methods of irrigation, levels and sources of fertilizers during 1994 and 1996	39
4.3	Number of leaves per plant in capsicum as influenced by methods of irrigation, levels and sources of fertilizers during 1994 and 1996	40
4.4	Leaf area index in capsicum as influenced by methods of irrigation, levels and sources of fertilizers during 1994 and 1996	42
4.5	Total dry matter accumulation in capsicum as influenced by methods of irrigation, levels and sources of fertilizers during 1994 and 1996	43
4.6	Dry matter distribution in capsicum as influenced by methods of irrigation, levels and sources of fertilizers during 1994 and 1996	45-47
4.7	Number of branches in capsicum as influenced by methods of irrigation, levels and sources of fertilizers during 1994 and 1996	51
4.8	Total green fruits yield in capsicum as influenced by methods of irrigation, levels and sources of fertilizers during 1994 and 1996 (kg/ha)	53
4.9	Green fruit yield in capsicum as influenced by methods of irrigation, levels and sources of fertilizers during 1994 and 1996	54

Contd..

TABLE NO.	TITLE	PAGE NO.
4.10	Total green fruit yield in capsicum as influenced by methods of irrigation, levels and sources of fertilizers during 1994 and 1996 (g/plant)	56
4.11	Number of green fruits per plant in capsicum as influenced by methods of irrigation, levels and sources of fertilizers during 1994 and 1996	57
4.12	Green fruit length in capsicum as influenced by methods of irrigation, levels and sources of fertilizers during 1994 and 1996	59
4.13	Green fruit girth in capsicum as influenced by methods of irrigation, levels and sources of fertilizers during 1994 and 1996	61
4.14	Ascorbic acid content at third picking in capsicum as influenced by methods of irrigation, levels and sources of fertilizers during 1994 and 1996	62
4.15	Plant height in maize as influenced by methods of irrigation, levels and sources of fertilizers during 1994 and 1996	64
4.16	Leaf area in maize as influenced by methods of irrigation, levels and sources of fertilizers during 1994 and 1996	66
4.17	Number of leaves per plant in maize as influenced by methods of irrigation, levels and sources of fertilizers during 1994 and 1996	68
4.18	Leaf area index in maize as influenced by methods of irrigation, levels and sources of fertilizers during 1994 and 1996	69
4.19	Total dry matter accumulation in maize as influenced by methods of irrigation, levels and sources of fertilizers during 1994 and 1996	71
4.20	Dry matter distribution in maize as influenced by methods of irrigation, levels and sources of fertilizers during 1994 and 1996	73-75
4.21	Days taken for 50% tasseling and 50% silking in maize as influenced by methods of irrigation, levels and sources of fertilizers during 1994 and 1996	80
4.22	Grain yield and stover yield in maize as influenced by methods of irrigation, levels and sources of fertilizers during 1994 and 1996	82
4.23	Yield attributes in maize as influenced by methods of irrigation, levels and sources of fertilizers during 1994 and 1996	84-85

Contd.

TABLE NO.	TITLE	PAGE NO.
4.24	Plant height in sunflower as influenced by methods of irrigation, levels and sources of fertilizers during 1995 and 1997	87
4.25	Leaf area in sunflower as influenced by methods of irrigation, levels and sources of fertilizers during 1995 and 1997	88
4.26	Number of leaves per plant in sunflower as influenced by methods of irrigation, levels and sources of fertilizers during 1995 and 1997	90
4.27	Leaf area index in sunflower as influenced by methods of irrigation, levels and sources of fertilizers during 1995 and 1997	92
4.28	Total dry matter accumulation in sunflower as influenced by methods of irrigation, levels and sources of fertilizers during 1995 and 1997	93
4.29	Dry matter distribution in sunflower as influenced by methods of irrigation, levels and sources of fertilizers during 1995 and 1997	95-96
4.30	Days taken for 50% flowering and stem diameter at harvest in sunflower as influenced by methods of irrigation, levels and sources of fertilizers during 1995 and 1997	100
4.31	Seed and stalk yield in sunflower as influenced by methods of irrigation, levels and sources of fertilizers during 1995 and 1997	102
4.32	Yield attributes in sunflower as influenced by methods of irrigation, levels and sources of fertilizers during 1995 and 1997	104-105
4.33	Oil content and oil yield in sunflower as influenced by methods of irrigation, levels and sources of fertilizers during 1995 and 1997	107
4.34	Nitrogen, Phosphorus and potassium content(%) on whole plant basis at harvest in capsicum, maize and sunflower as influenced by methods of irrigation, levels and sources of fertilizers during 1994-95 and 1996-97	110
4.35	Nitrogen, Phosphorus and potassium uptake by capsicum as influenced by methods of irrigation, levels and sources of fertilizer during 1994 and 1996	111
4.36	Nitrogen, Phosphorus and potassium uptake by maize as influenced by methods of irrigation, levels and sources of fertilizer during 1994 and 1996	113

Contd..

TABLE NO.	TITLE	PAGE NO.
4.37	Nitrogen, Phosphorus and potassium uptake by sunflower as influenced by methods of irrigation, levels and sources of fertilizer during 1995 and 1997	115
4.38	Fertilizer use efficiency in capsicum, maize and sunflower as influenced by methods of irrigation, levels and sources of fertilizers during 1994-95 and 1996-97	117
4.39	Soil moisture status in 0-60 cm layer as influenced by methods of irrigation	120
4.40	Irrigation water use efficiency in capsicum, maize and sunflower as influenced by methods of irrigation, levels and sources of fertilizers during 1994-95 and 1996-97	121
4.41	Root dry weight in capsicum, maize and sunflower at final harvest as influenced by methods of irrigation, levels and sources of fertilizers during 1994-95 and 1996-97	123
4.42	Root mass distribution in capsicum, maize and sunflower as influenced by methods of irrigation, levels and sources of fertilizers in relation to soil depth during 1994-95 and 1996-97	125
4.43	Residual soil NO ₃ -N distribution after the harvest of capsicum, maize and sunflower as influenced by methods of irrigation, levels and sources of fertilizers during 1994-95 and 1996-97	128
4.44	Residual soil P distribution after the harvest of capsicum, maize and sunflower as influenced by methods of irrigation, levels and sources of fertilizers during 1994-95 and 1996-97	131
4.45	Residual soil K distribution after the harvest of capsicum, maize and sunflower as influenced by methods of irrigation, levels and sources of fertilizers during 1994-95 and 1996-97	134
4.46	Economic analysis of fertigation in capsicum-maize-sunflower cropping sequence in 1994-95	136
4.47	Economic analysis of fertigation in capsicum-maize-sunflower cropping sequence in 1996-97	138
4.48	Economic analysis of fertigation in capsicum-maize-sunflower cropping sequence in 1994-95 and 1996-97	139

LIST OF FIGURES

<u>FIGURE NO.</u>	<u>TITLE</u>	<u>BETWEEN PAGES</u>
3.1	Total monthly rainfall and mean daily evaporation at Main Research Station, Hebbal during experimental period	26-27
3.2	Plan of layout and schematic diagram of drip irrigation system	28-29
4.1	Leaf area in capsicum at 90 DAP as influenced by fertigation, drip and furrow with levels and sources of fertilizer (mean of two years)	39-40
4.2	Total dry matter in capsicum at final harvest as influenced by fertigation, drip and furrow with levels and sources of fertilizer (mean of two years)	44-45
4.3	Green fruit yield in capsicum as influenced by fertigation, drip and furrow with levels and sources of fertilizer (mean of two years)	53-54
4.4	Number of green fruits per plant in capsicum as influenced by fertigation, drip and furrow with levels and sources of fertilizer (mean of two years)	57-58
4.5	Ascorbic acid content in capsicum as influenced by fertigation, drip and furrow with levels and sources of fertilizer (mean of two years)	62-63
4.6	Leaf area in maize at 60 DAS as influenced by fertigation, drip and furrow with levels and sources of fertilizer (mean of two years)	66-67
4.7	Dry matter at harvest in maize as influenced by fertigation, drip and furrow with levels and sources of fertilizer (mean of two years)	71-72
4.8	Grain yield in maize as influenced by fertigation, drip and furrow with levels and sources of fertilizer (mean of two years)	82-83
4.9	Stover yield in maize as influenced by fertigation, drip and furrow with levels and sources of fertilizer (mean of two years)	82-83
4.10	Leaf area in sunflower at 60 DAS as influenced by fertigation, drip and furrow with levels and sources of fertilizer (mean of two years)	88-89

Contd..

<u>FIGURE NO.</u>	<u>TITLE</u>	<u>BETWEEN PAGES</u>
4.11	Dry matter in sunflower as influenced by fertigation, drip and furrow with levels and sources of fertilizer (mean of two years)	93-94
4.12	Seed yield in sunflower as influenced by fertigation, drip and furrow with levels and sources of fertilizer (mean of two years)	102-103
4.13	Oil content and oil yield in sunflower as influenced by fertigation, drip and furrow with levels and sources of fertilizer (mean of two years)	107-108
4.14	N, P and K uptake in capsicum as influenced by fertigation, drip and furrow with levels and sources of fertilizer (mean of two years)	111-112
4.15	N, P and K uptake in maize as influenced by fertigation, drip and furrow with levels and sources of fertilizer (mean of two years)	113-114
4.16	N, P and K uptake in sunflower as influenced by fertigation, drip and furrow with levels and sources of fertilizer (mean of two years)	115-116
4.17	Fertilizer Use Efficiency in capsicum, maize and in sunflower as influenced by fertigation, drip and furrow with levels and sources of fertilizer (mean of two years)	118-119
4.18	Irrigation Water Use Efficiency in capsicum, maize and sunflower as influenced by fertigation, drip and furrow with levels and sources of fertilizer (mean of two years)	121-122
4.19	Root distribution pattern in capsicum, maize and sunflower as influenced by fertigation, drip and furrow with levels and sources of fertilizer (mean of two years)	126-127
4.20	Residual soil NO ₃ -N after harvest of capsicum, maize and sunflower as influenced by fertigation, drip and furrow with levels and sources of fertilizer during 1994-95	129-130
4.21	Residual soil P after harvest of capsicum, maize and sunflower as influenced by fertigation, drip and furrow with levels and sources of fertilizer during 1994-95	131-132
4.22	Residual soil K after harvest of capsicum, maize and sunflower as influenced by fertigation, drip and furrow with levels and sources of fertilizer during 1994-95	134-135
4.23	Cost : Benefit ratio in capsicum, maize and sunflower as influenced by fertigation, drip and furrow with levels and sources of fertilizer (mean of two years)	138-139

LIST OF PLATES

<u>PLATE NO.</u>	<u>TITLE</u>	<u>BETWEEN PAGE S</u>
3.1	General view of the experimental plot	30-31
3.2	Wetting pattern under Chapin pipe	30-31
3.3	Fertigation tank with sand and mesh filters	30-31
3.4	Kemira 100% Water Soluble Fertilizers	30-31
5.1	Root growth in capsicum as influenced by furrow, drip and fertigation treatment	145-146
5.2	Root growth in maize as influenced by furrow, drip and fertigation treatment	145-146
5.3	Root growth in sunflower as influenced by furrow, drip and fertigation treatment	145-146
5.4	Capsicum crop grown under furrow irrigation	148-149
5.5	Capsicum crop grown under drip irrigation	148-149
5.6	Capsicum crop grown under fertigation	148-149
5.7	Maize crop grown under furrow irrigation	150-151
5.8	Maize crop grown under drip irrigation	150-151
5.9	Maize crop grown under fertigation	150-151
5.10	Sunflower crop grown under furrow irrigation	151-152
5.11	Sunflower crop grown under drip irrigation	151-152
5.12	Sunflower crop grown under fertigation	151-152

INTRODUCTION

I. INTRODUCTION

Irrigation water, fertilizers and other inputs along with quality seeds and human management of the resources form the foundation of modern agriculture. Though India is blessed with abundant water resources, due to various constraints, the utilizable water for irrigation is very limited. Therefore technological innovations are to be exploited to achieve the twin objectives of higher productivity and better water use efficiency. Micro or drip irrigation has revolutionized irrigated agriculture in many countries of the world. In Israel, the entire area is now irrigated by drip systems. Similar trend is noticed in USA, Australia, Southern Europe and many other developing countries.

Drip irrigation has shown convincingly superior results, wherever it is adapted. More than two million ha are under drip irrigation for about 60 crops in the World, whereas in India, from literally no area under drip in 1970s, it has increased to around 80,000 ha in 1995 feeding 20 crops mainly in Maharashtra, Tamilnadu and Karnataka states.

The consumption of fertilizers in India, as an inevitable input of agricultural production has reached 20 million tons today from a meager 0.5 m. ton in the early 50's. However, escalating prices per unit fertilizers applied especially owing to import of raw materials for their production coupled with their low use-efficiencies with nutrients liable to be leached down or volatilized cause a serious concern. Under these circumstances, fertigation, a sophisticated and efficient method of applying fertilizers through drip irrigation system as a carrier and distributor of crop nutrients holds bright promise. The synergism of water and nutrients leads to efficient use of both by the plants. Fertigation technology which initially included only plant nutrients is expanding however, owing to advances in the irrigation system design, improved chemical injection equipments, computerization of operations, and use of wide range of agrochemicals including plant protection chemicals, growth regulators etc. and is generally termed as ' Chemigation ' .

Fertigation also offers advantages like optimizing nutrient balance by supplying nutrients directly to the root zone in easily available form, control of nutrient concentration in soil solution to effect proper supply, flexibility of fertilization to match crop nutritional requirements at different stages of its growth, saving in application costs and improvement in soil conditions due to better distribution and proper maintenance of soil moisture levels. Promising results indicating a saving of upto 40% of fertilizer by fertigation method besides substantial saving of water have been noticed in several parts of the world.

Fertilizer materials used for fertigation must be completely soluble in water and must not react with substances in irrigation water to form insoluble precipitates. Hence fully water soluble fertilizers (WSF) are being manufactured for easy application through drip system. Kemira Agro, Finland have developed many grades of WSF and in these fertigation studies the 30:10:10 and 19:19:19 grades have been examined.

Capiscum annum L. is an important vegetable crop rich in Vitamin C and A cultivated in many parts of India both for home market and export. Also called bell pepper it has attained the status of a high value crop in India during recent years as it fetches high market price from the urban consumers. In Karnataka it is grown over an area of 3471 ha with the production of about 23602 tons (1994-95). The average productivity is very low (6-8 tons/ha) in India. However, its potential is about 20 tons per ha under good management (Joshi and Singh, 1975).

Maize is the third important cereal after rice and wheat as food crops. It occupies an area of 3.44 lakh ha in Karnataka with 9.87 lakh tons of grain production (1994-95). Maize is grown for its grain and the whole plant or stover is fed to animals. The starchy grain itself is used as food and as the main constituent of feed to domestic animals besides its use as a source of starch in a number of chemical industries.

Sunflower is an important oilseed crop of the World ranking second in production next only to groundnut in Karnataka. This state has the maximum area of 8.4 lakh ha with an annual production of 3.6 lakh tons (1994-95). It has been well accepted by the farming community because of its desirable attributes like low seed rate, high seed multiplication rate (1-100), short duration, photo insensitivity, high water use efficiency and high oil content (42-46%) of superior quality rich in poly unsaturated fatty acids.

All these crops require adequate fertilization and timely irrigation for attaining higher productivity. The major limitation for achieving higher returns from these crops in Karnataka is the shortage of groundwater. Adoption of modern and efficient methods of irrigation is one of the avenues to increase the output and at the same time to save precious water and fertilizer. Therefore, to evaluate the feasibility of fertigation technology in a cropping sequence, field experiments entitled "Effect of fertigation with normal and water soluble fertilizers compared to drip and furrow systems in Capsicum-Maize-Sunflower cropping sequence" were conducted at the Main Research Station, University of Agricultural Sciences, Hebbal, Bangalore during the years 1994-95 and 1996-97 with the following objectives:

- a) To determine the water and fertilizer use efficiencies in capsicum, maize and sunflower as influenced by methods of irrigation and fertilization, levels and sources of fertilizers,
- b) To study the root distribution pattern in relation to soil depth as influenced by irrigation and fertilization methods, levels and sources of fertilizers,
- c) To study the effect of furrow, drip and fertigation, levels and sources of fertilizers on growth, quality and yield of capsicum, maize and sunflower crops in a sequence,
- d) To study the residual soil nutrient status and its distribution as influenced by irrigation and fertilization methods, levels and sources of fertilizers, and
- e) To assess the economic viability of fertigation in capsicum-maize-sunflower cropping sequence.

REVIEW OF LITERATURE

II REVIEW OF LITERATURE

In India, fertigation practice is only of recent interest, though this technology has been in use in many developed countries notably in Israel and U.S.A. What is also new for most countries is the adoption of fertigation system for an entire cropping system with such crops as capsicum – maize and sunflower as has been examined in the current research study. The literature pertaining to the Fertigation studies with water-soluble and normal fertilizers in Capsicum – Maize – Sunflower cropping sequence is presented hereunder. This review is dealt under the following headings.

1. Development of fertigation
2. Fertilizers suitable for fertigation
3. Movement of nutrients in soil followed by fertigation
4. Fertigation studies in Capsicum
5. Fertigation studies in Maize
6. Fertigation studies in Sunflower
7. Effect of trickle fertigation on root distribution
8. Future of fertigation

2.1, Development of fertigation

Fertigation as a method of combined application of water and plant nutrients only started commercially in the mid 20th century although there is evidence that the concept of irrigation with dissolved nutrients was well known in the past. The first reported example dates back to ancient Athens (4000 BC), where city sewage was used for irrigation of tree groves (Young and Hargett, 1984). In commercial fertigation, liquid ammonia was probably the first produced liquid fertilizer. However, in modern fertigation, the use of ammonia is negligible because of the development of mechanical ammonia application technology directly to soil through drills, knives and injection tubes, etc., is cumbersome and is known to be risky.

Fertigation with phosphoric acid was demonstrated by shell chemical company in 1943 and ten years later the first NPK solution was made by mixing phosphoric acid neutralized with ammonia and with an addition of potash to create 40-10-10 grade solution (Young and Hargett, 1984).

In promoting modern fertigation, the development of Micro-Irrigation-Systems (MIS) was one of the important factors. This opened a new era of fertigation. Field experiments in Israel in the early 1960's showed that when only part of the field area was irrigated as in MIS, the use of standard broadcast application of fertilizers was ineffective. The broadcast fertilizers resulted in reduced nutrient availability to the plants because of the limited root zone and the reduced amount of mineralization in the restricted wetted zone. Recognition of these facts lead to the development fertigation technology of providing fertilizers with applications of MIS which included drip, jets and microsprinklers. In Israel, fertigation is by far the most common, and in some cases the only method of fertilizing greenhouses, orchards, vegetables and drip irrigated field crops such as maize, cotton, jujube etc.

Irrigation system followed in India being mainly through surface flow in the channels and distributories though not completely the flood method, results in huge loss of water. Besides, the applied fertilizer nutrients are either leached down or subject to surface run off to neighbouring fields.

In this context, fertigation through a trickle irrigation system offers several advantages like (i) increased use efficiency of both water and fertilizer, (ii) optimization of nutrient balance by supplying nutrient directly to active root zone in available forms, (iii) flexibility of fertilizer application in accordance with crop nutrient demand, (iv) reduced labour, (v) reduction in groundwater pollution by minimizing leaching below the rooting volume and (vi) reduced soil erosion (Steduts, 1984; Haynes, 1985; Hagin, 1996). On the other hand, there may be some
^{and lowengart}
 ^

disadvantages like unequal distribution of nutrients in the field, the possibility of over-irrigation or leaching and the possibility of chemical reaction in the irrigation system (Haynes, 1985).

Requirements in order to effect uniform distribution include well maintained irrigation system in which every emitter delivers same quantity of water during the irrigation period.

Application of fertilizer material into irrigation water can be achieved by simple systems such as ventury (Vacuum) or by-pass tanks as well as through sophisticated computer controlled systems.

2.2 Fertilizers suitable for fertigation

Fertigation practice is becoming more popular because of the availability of completely water-soluble fertilizer materials of high grade. These fertilizers are made of same chemical compounds as those of normal fertilizers but, they are devoid of neutral insoluble materials such as earth, gypsum, dolomite, clay etc. Therefore, with pure nutrients in the manufactured products, they are 100% soluble in water without leaving any sediments in fertigation or clog the sprayers when applied as foliar spray.

2.2.1 Nitrogen fertilizers

Nitrogen is the nutrient most commonly used in fertigation with MIS, flood irrigation, moving laterals and in overhead sprinklers. In general, all N fertilizers cause few precipitation and clogging problems. The different nitrogen sources that could be employed for fertigation are anhydrous ammonia, ammonium phosphate, urea, ammonium nitrate and calcium nitrate. Careful consideration must be given to pH in the irrigation water since some of the N sources cause increase in pH leading to precipitation with calcium and magnesium and clog the drip system.

Urea is best suited for fertigation because it is highly soluble and does not react with water to form ions unless the enzyme urease is present. Possibility of such enzyme breakdown is less in fertigation since only a limited area of top soil with greater microbial activity is in contact. The nitrogen use efficiency could be as high as 90 per cent compared to 40-60 per cent in conventional method of application. Alternative wetting and drying of soil in conventional flood irrigation also leads to greater denitrification loss which is particularly absent with fertigation.

Calcium nitrate, ammonium polyphosphate, ammonium thiosulphate, ammonium nitrate, calcium ammonium nitrate urea, urea ammonium nitrate have all been successfully used as liquid N fertilizers for fertigation in Washington orchards. Careful evaluation of soil type, trees and irrigation management is necessary in selecting most appropriate type (Paryea, 1992).

2.2.2 Phosphorus fertilizer

Application of phosphorus to irrigation water may cause precipitation problems. Phosphoric acid which is the concentrated form of phosphate, containing 20 to 32% P could be used in fertigation as a source of phosphorus. This also aids in cleaning the system of chemical deposits.

If irrigation water is low in calcium and magnesium, few problems should be encountered in applying phosphoric acid through trickle system. In such situations, ammonium or potassium dihydrogen orthophosphate could also be used. Other soluble fertilizers available as P sources are ammonium polyphosphates and nitrophosphates. A fertilizer compatibility test with the irrigation water should be conducted before injecting soluble P fertilizer in a trickle irrigation system (Mikkelsen, 1989).

2.2.3 Potassium fertilizers

The common sources of potassium (Potassium chloride, potassium sulphate and potassium nitrate) are readily soluble in water and do not cause any precipitation problem in trickle lines and emitters.

2.2.4 Micronutrients

Micronutrients such as iron, manganese, zinc and copper can be applied to irrigation water in chelated form without causing precipitation problems. Nevertheless, if such micronutrients are added as inorganic forms, they could possibly react with salts in the irrigation water and cause precipitates (Haynes, 1985).

2.3 Movement of nutrients followed by fertigation

Under fertigation, movement of the nutrients in the soil is largely determined by the cation exchange capacity of the soil and the electrostatic charge of the particular nutrient, the waterflow through the soil and plant nutrient uptake. The charged nutrient ions i.e., ammonium, potassium, calcium and magnesium are dependent on the degree of saturation and exchange capacity of the soil. A sandy soil has less exchange sites than a loamy soil and a loamy soil less than a clayey soil. Therefore, nutrient movement in sandy soils occurs more readily than on a loamy or clayey soils.

2.3.1 Nitrogen

The initial distribution of nitrogen added to the soil from trickle emitters is likely to differ markedly depending upon the source and rate of nitrogen applied. Ammonium if applied at lower rate, the ammonium cation will be sorbed onto soil colloids and move only a small distance from the emitter. As the concentration of ammonium ions increases sufficiently to overcome the cation exchange capacity (CEC) of the soil, ammonium will move further. The extent of movement will, therefore, depend on the CEC of the soil and the rate of ammonium application.

Urea is relatively mobile in soils and is not strongly absorbed by soil colloids. It therefore tends to be more evenly distributed within the wetted profile than does applied ammonium (Black, 1976).

The highly mobile nitrate ion moves with the wetting front of the irrigation application and tends to accumulate at the periphery of the wetted soil volume and at the soil surface midway

between emitters (Dalbro and Dorp h-Peterson, 1976). In well aerated soils, nitrification occurs, thus mobility of nitrogen is not restricted and is equal to that of wetted front (Haynes, 1985). In over-irrigation leaching of nitrate will occur if nitrogen is present in surface and underground water sources. Monitoring the depth of the wetted front and/or the concentration of nitrate in soil extract can reduce this risk in sandy soils (Magen, 1995).

Using bromide and chloride as indicators of nitrate movement, Gratez *et al.* 1978 in capsicum clearly demonstrated that greater lateral movement and less downward movement can be achieved by increasing the discharge rate even on a sandy soil. This suggests that faster discharge rates may improve the distribution of soluble nutrients particularly for surface rooting crops. Though denitrification process is an anaerobic one and is therefore generally stimulated by increasing soil moisture content, as the nitrate moves outward with the wetting front, the potential for denitrification decreases so that losses of N through this mechanism may be small.

2.3.2 Phosphorus

The mobility of phosphorus followed by fertigation is restricted due to its strong retention by soil oxides and clay minerals, but continuous application of orthophosphate through fertigation proved to be superior to applying P as basal dress (Bar-Yosef, 1991). In contrast, in many vegetable fields in USA, P is applied via fertigation.

Generally, if a more or less uniform concentration of phosphate in the rooting volume is desired, then a basal, soil incorporated dressing will be required (Goldberg *et al.* 1976). Under normal agricultural conditions, however, the distribution of phosphate within the rooting zone is not uniform since applied phosphate characteristically accumulates close to the soil surface.

2.3.3 Potassium

Potassium ion is adsorbed at the cation exchange sites of soil colloids, but researchers have shown lateral and downward mobility of potassium when applied via drip irrigation (Magen, 1995,

Haynes, 1985) showed that the distribution of potassium was more uniform than that of either nitrate or phosphate.

2.3.4 Micronutrients

Micronutrient cations such as Zn^{2+} and Cu^{2+} are characteristically immobile in soils. Even when they are added through trickle irrigation system as mobile chelates they are not likely to move far in the soil profile. This is because once in the soil, the micronutrient metal ions are displaced from the chelate by other ions (eg. Ferric ions) which are present in the soil in high concentrations (Mc Laren and Williams, 1981). Thus, the effectiveness of soil applied chelates is not normally any greater than that of simple inorganic compounds.

2.3.5 Significance of non-uniform distribution of nutrients under fertigation

The uneven distribution of nutrients with the root zone caused by trickle fertigation may be undesirable. But Haynes,(1985) suggested that plants can adapt to spatial variability of available nutrients through increased rate of nutrient uptake per unit weight or length of roots in the nutrient enriched area and localized root proliferation occurring in the zones of soil high in nutrients in order to compensate for an uneven distribution of nutrients within the potential rooting zone.

2.4 Fertigation studies in Capsicum

Sagiv *et al.* (1978) reported that organic manure applied at 30 or 90 tons per hectare, N at 130, 260 or 390 kg/ha and P at 750 or 1500 kg as super phosphate and sprinkler irrigation applied daily, it was observed that 60 per cent of capsicum yield was obtained at the first of three harvests and the highest yield (31 t/ha) was obtained with 390 kg N and 1500 kg super phosphate. when these fertilizers were applied through trickle system, yields (74 t/ha) were higher than those under sprinkler (59 t/ha).

In an experiment designed to compare different fertilization techniques, capsicum was grown with fertigation, banded application of fertilizer + drip irrigation, broadcast fertilizer

application + drip irrigation and one control treatment. Yield of pepper plants increased with maturity until the plants were five months old. Fertigation treatment had the steepest and smoothest increasing rate and also the highest total yield. Banded fertilizer application followed a close second in terms of total yield. Yield from broadcast fertilizer treatments were 15.8% lower than from fertigation and 12.3% lower than banded fertilizer. The check plots did not show much improvement with maturity. Finally Keng and ^{Lugo-Lopez} (1979) concluded that drip fertigation can be a promising alternative to currently used water nutrient management method for oxisols in the wet dry tropics.

Tropea *et al.*, (1982) reported that application of 313, 214 and 538 kg N, P₂O₅ and K₂O in the form of liquid fertilizer formulation given monthly through fertigation for capsicum grown in two sandy soils under glass resulted in highest yield than an organic fertilizer supplying N, P₂O₅ and K₂O at 364, 768 and 564 kg/ha. Fertigated plants receiving 9, 18 or 30 g urea per plant out yielded plants receiving side-dressed urea (15 g at planting + 15 g after first harvest) (Goyal *et al.*, 1985).

Martinez Canadas *et al.*, (1985) revealed that the leaf area and leaf fresh weight of sweet peppers in a greenhouse were greater with fertigation than with flood irrigation. After 100 days of growth, intermittent fertilizer supply to the soil surface resulted in greater leaf fresh weight but smaller leaf area than continuous fertilizer supply by fertigation.

Study conducted by Haes *et al.*, (1987) revealed that P fertigation controlled early season stunting. Plants fertigated with 1.3 mM P/litre weighed the most 9 weeks after seeding. After 9 weeks, all plots were fertigated with 0.6 mM P/lit. Yields were high (61-65 mg/ha) where 0.4 mM P/litre and more was supplied early in the season and highest (73.74 mg/ha) where both P fertigation and VAM (VA mycorrhiza) inoculation were used

Crespo-Ruiz *et al.*, (1988) studied the effect of drip fertigation with urea at 500, 300 or 150 kg N/ha in 11 applications or at 500 kg N/ha side dressed 6th and 56th day after transplanting

capsicum (cv. Cubanelle). The relationships between N, P, K and growth parameters versus days after transplanting as determined by a Mischerlich-curve-type equation indicated 5 phases of nutrient uptake. Coefficient of determination varied from 0.55 to 0.85 for growth parameters and from 0.70 and 0.99 for nutrient uptake. Fertigation with 300 kg N/ha produced the highest commercial yield (51.2 t/ha) compared with fertilization (31.0 t) and control (20.8 t).

Haynes (1988) made a comparative study of fertigation with broadcast application of urea-N on levels of available soil nutrients and on growth and yield of trickle irrigated peppers. Of the different treatments evaluated, it was observed that 75 kg of urea-N given as fertigation gave maximum vegetative plant growth and yield while 150 kg urea-N when fertigated induced Al toxicity due to soil acidification below the emitters. This suggests that higher than optimum rates not only represent an economic loss, but can also have damaging effect on crop growth. Broadcast at 150 kg N yielded lesser when compared to fertigated pepper at 75 kg.

Marchesi and Cattivelli (1988) reported that plant height, stem thickness, plant weight and total DM between plants of *Capsicum annuum* cv. Sansone F1 seedlings were increased by fertigation using the compound product Idronova (21:7:14:2 of N:P:K:Mg) as compared to unfertilized plants.

N fertigation (as urea) at 150, 300 or 500 kg N/ha via 11 irrigations or at 500 kg/ha as side dressing on 2 dates had positive effect on fruit width, length, weight and number (Goyal *et al.* 1989).

Levels of nitrogen applied as ammonium nitrate in trickle irrigation at 3 rates (67.5, 45.0 and 22.5 kg/ha) did not cause any significant response. However, marketable yields in both 1987 and 1988 increased with irrigation rate, the highest yields being obtained at 90% of fractional soil volume (FSV). Total leaf N content increased as the irrigation rate increased from 25 to 75% FSV and then remained constant (Madramootoo and ^{Rigby} 1989).

In a study conducted by Payero *et al.* (1990), solubilized NH_4NO_3 was applied through Trickle-irrigation system (total season N ranging from 240 to 310 kg/ha) to ensure uniform and timely applications. Rate of mature (green or red) chilli cv. Anaheim fruit production was unaffected by any treatment except weekly application of 28 kg N/ha, which stopped production of mature fruits before all other frequency of application. Total fruit production was maximized at 240 kg N/ha. Differences in total fruit production due to frequency of N application resulted at the highest total N level. N use efficiency (NUE) for red fruit production also decreased with N rates increasing to 240 kg/ha, but pure live seed yield (PLS) and NUE decreased in a near-linear fashion as the amount of total seasonal N increased, regardless of application frequency. The findings indicated that different N management strategies were needed to maximize seed yield compared with fruit yield.

Capsicum fruit yield and mean fruit size peaked at 252 kg N/ha supplied in the form of Urea:ammonium nitrate mixture (UN 32) in weekly treatments through drip-irrigation with additional N retarding the crop productivity. Maximum fruit yield was obtained by fertility treatment that maintained petiole $\text{NO}_3\text{-N}$ concentration at >500 $\mu\text{g/g}$ through the early fruit bulking period (Hartz *et al.*, 1993).

Olsen *et al.* (1993) investigated effect of N fertilization in bell pepper cv. Belltower grown with plastic mulch and trickle irrigation in the Bundaberg region of Australia. N was applied at 0, 70, 140, 210 or 280 kg/ha in 10 equal doses weekly through the irrigation system. Maximum dry weight (kg/ha) of fruits, leaves, roots and stems and maximum fresh weight of marketable fruits were obtained with 210-280 kg/ha. N uptake was equal to the applied rate at 140 kg/ha. Plant uptake of elements increased with applied N and, at 280 kg N/ha were ranked in as follows : $\text{K} > \text{N} > \text{Ca} > \text{Mg} > \text{S} > \text{P}$. Fruits accumulated the greatest proportion of total K, N and P (40/64%, 40/64%, 49/76% for spring/autumn crops, respectively). The efficiency of fruit production from absorbed applied N declined with increasing N rates.

Yield of drip fertigated capsicum was neither affected by rate of nitrogen nor application timing in both the years 1991 and 1992. Mid or late-season fertigation produced more second harvest yield and less discards than the first harvest in 1991 but not in 1992. Fruits of plants fertilized with high N and K rates had greater N and dry matter concentration. No differences in colour or wall thickness at harvest were detected among the treatments (Carbollo *et al.* 1994).

Storlie *et al.* (1995) studied the effects of fertilizer rates and application frequency on drip fertigated *Capsicum annum* (cultivars Bell Captain, Gator Belle and Camelot) in southern New Jersey. Yield and fruit quality were greatest with 158 lb N + 69 lb P + 131 lb K/acre at the site with sandy loam soil. Average marketable fruit weight increased with increasing fertilizer rate and at one of the two loamy sand sites. Increasing the frequency of fertilizer application from every 11 to every 22 days did not affect yield or fruit quality in either year when the same total amount of fertilizer was applied. The results show that maximizing the yield of bell peppers grown on loamy sand soils in New Jersey may require high fertilizer rates, than previously recommended.

All these results thus indicate that capsicum responds well to fertigation with 11 to 22 applications in terms of increased growth and yield properties compared to conventional method of fertilization.

2.5 Fertigation studies in Maize

Response of maize under fertigation has been studied extensively in USA and Israel.

2.5.1 N fertigation

Grain yields of fertigated maize and N, P, K, Mg and S contents of the ear leaf sampled at silk emergence were comparable to those resulting from conventional fertilizer and water application in Georgia coastal plain (Mitchell *et al.* 1982).

In a sandy loam soil, sidedress and fertigation of UAN (fluid ammonium nitrate) application were about equal in effect on grain yield. If UAN was banded, single supplemental

application was effective. Fertigation was also effective, but split applications of N were needed as per needs of crop (Gascho and Hook, 1984).

The effect of N carriers anhydrous ammonia, ammonium sulfate, ammonium nitrate and urea applied at 200 kg N/ha in surface irrigation water were compared with band application of anhydrous ammonia and a control on growth and yield of maize and N status of was studied by Muirhead *et al.* (1985). Urea was superior to ammonium forms of N, while the nitrate carriers were the least efficient. Urea increased the maize yield by 27% when compared with the band application. Fertigation allowed N to be applied during the grand period of growth when N stress was more likely to occur. Recovery of N was highest for urea.

Camp *et al.* (1986) evaluated two surface and subsurface trickle tubing placements in both pulsed and continuous models to apply irrigation water and fertilizer on maize. No differences in yields were found among treatments except during extreme drought.

Application of 150 kg NPK in irrigation water at flowering with or without 20 kg ZnSO₄/ha as side dressing resulted in maize grain yield of 8.27 t compared with 6.99 t/ha in traditional method. This new technique seemed promising for maize production in Aragon, Spain particularly on heavier badly-drained soils and soils and under conditions of water shortage (Casallo, 1988).

In the alluvial plains of the river Ariege (France), fertigation (split N application in the irrigation water) proved more economical than applying all the fertilizer at the beginning of the cropping season. Fertigation resulted in higher maize yields and better grain-N to total-N ratios, reduced pollution by eliminating N accumulation in spring (the rainy season), and decreased leaching. In addition, any residual N from late applications remained available for the following crops (Cosserat *et al.*, 1990).

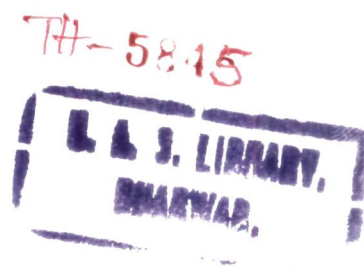

Bullock *et al.* (1990) in field trials at Tifton, USA found that 168, 252 and 336 kg N/ha applied in 4 equal fertigation and 44, 73 and 103 kg P and 84, 223 and 363 kg K/ha/year soil applied to maize in maize/groundnut rotation, grain yields were not significantly affected by N, P or K rates. It is suggested that (at least 1 year) NUE of a fertigated maize crop may be improved by dressing N fertilizer rates below current recommendations. Tissue N, P and K Conc. increased with decreased N, P and K application respectively. Reducing N, P and K application, however, did not affect concentration of these and other nutrients in plant tissues.

In an investigation regarding N uptake efficiency of NO_3 applied with irrigation water and the fate of fertilizer using stable isotope ^{15}N as a tracer, the uptake efficiency of the side-dressed N fertilizer was not affected by the application of N in the irrigation water. The NUE of the NO_3 -applied through fertigation was negatively correlated with the amount of side-dressed fertilizer N. Second year recovery of ^{15}N applied in irrigation water was greater at the highest rates (100 kg N/ha) of fertilizer and irrigation N. The lack of response according to Francis, (1990) is attributed to the relatively high level of residual soil N and the high amount of mineralized N.

Gascho and Hook (1991) worked to develop fertigation program for sprinkle irrigated corn on sandy soils near Tifton, Georgia using ammonium nitrate. With one application, grain yields were greatest with surface dribbled N and silage yields were greatest with broadcast or fertigated N. With four N applications, grain and silage yields were greatest with fertigation. With optimum irrigation, fertigation was more cost effective than dribbling N.

Sweet corn cv. Jubilee was given N, P and K in drip irrigation either on the soil surface (S) or 30 cm below the surface (SS) : Marketable and total ear yields were higher with SS fertigation (3.22 and 4.90 kg/m² respectively). Total FW, DM production and plant height during the growing season were also greater for SS emitters (Martinez – Hernandez, 1991).

Girardin *et al.* (1993) investigated the effect of conventional and multiple N application by fertigation on maize. Maize cv. DEZ was side-dressed with urea by hand to supply

170 or 220 kg N/ha over the growing season with an irrigation (7 or 14 mm) treatment after each fertilizer to simulate fertigation. There was no influence of fertilizer application method on maize grain yield and yield components. However, the residual soil-N was higher after multiple side-dressed N application, even at lower N rate. N fertigation at the conventional N rate (220 kg/ha) increased the risk of N leaching after maize harvest, but applying N at lower rates may decrease grain yield. It is concluded that if nitrate leaching is a potential risk, N fertigation is not recommended, unless N fertilizer requirement can be calculated accurately.

Influence of fertigation with different N sources and doses related to crop production and nutrient uptake of corn was studied by Hamdy *et al.* (1993). Application of 140 kg N/ha resulted in a corn yield more or less equal to that of 210 kg N/ha dose with a notable increase over 70 kg/ha. Short application frequencies rather than the long one resulted a greater improvement in the yield as well as in the plant growth parameters irrespective of the N source or the rate at which it was applied. This was also true for the plant uptake of both P and K. The NUE calculation clearly confirmed that among fertigated treatments, the highest efficiencies were obtained from those where nitrogen distributed at the same frequencies as those of irrigation.

Watts *et al.* (1994) evaluated different strategies for fertigation of maize during surge irrigation on three Nebraska, USA Soils : a silt loam, a loam and a loamy sand. A fertigation application of 33 kg/ha of N was assumed for all cases. Strategies providing the highest uniformity of N application on the silt loam soil were the worst on the loamy sand, and vice versa. For silt loam soils with moderate to low intake rates, fertigating during the advance cycles may be the best strategy. Applying N throughout the irrigation was an acceptable alternative. For deep loam soils with a medium intake rate, the best strategy was to apply N throughout the irrigation. For a loamy sand, fertigation only during the cutback appeared to be the best strategy. Suboptimal strategies may contribute to groundwater contamination instead of reducing it.

In Sao Paulo State, Brazil sprinkler fertigation of urea at 120 kg N/ha at seven advanced growth stages did not decrease nitrate losses, but increased N accumulation and grain

production in plants in comparison to band placement of urea at two growth stages (Basso and Reichardt, 1995).

Blackmer and Schepers (1995) identified that early season N deficiencies in corn at Nebraska were poorly correlated with factors such as nitrate leaching, organic matter mineralization and nitrate present in irrigation water. Nitrogen deficiencies detected late in the season were highly correlated with yield than early season N stress and hence it would be appropriate to supply N fertilizer by fertigation during later crop growth stages without yield losses.

Lysimetric study of cropping techniques for reducing nitrate leaching was conducted in France. Results showed that decreasing applied N fertilizer reduced nitrate leaching and maize yields. Fertigation reduced leaching but there were some pollution risks. Only cultivating a green manure crop after maize crop eliminated nitrate leaching without decreasing the yield (Decau and Pujol, 1995).

Watts and Schepers (1995) opined that fertigation can be practised by centre pivot irrigators to apply N to maize crops throughout the rapid uptake period, thus synchronizing N application with peak crop needs. A chlorophyll meter can be used to check crop N status on a weekly basis. In contrast, fertigation has not been a viable option for the typical furrow irrigator. The use of a combination of fertigation and surge flow irrigation made it possible for furrow irrigators to apply supplemental N fertilizer later in the season with a reasonable uniform distribution.

2.5.2 P fertigation

Bar-Yosef *et al.* (1989) tested the hypothesis that subsurface placement of emitters is more effective in stimulating P uptake than surface placement when P was applied at 0.04, 0.16, 0.64 and 1.29 mol/m³ in irrigation water via drip system. Marketable ear yield increased with P concentration yielding 22.9, 24.3, 24.9 and 28.9 t/ha respectively. Yield was higher for tricklers placed 30 cm below soil surface (25.2 t/ha) than on the surface (23.5 t/ha). Elevated P concentration

of irrigation water increased the soil solution P concentration. Thereby increasing total P uptake and total DM production by the plant. Deep trickler placement significantly increased the fraction of total DM allocated to the ears, which resulted in high marketable yield.

From the foregoing, it can be concluded that fertigation can be practised via drip, sprinkler or furrow/surge methods of irrigation with various degree of advantages in maize. Nitrogen supplied at later stages of crop growth improves maize yields considerably than early stage applications. Accurate quantity of fertilizer and fertigation frequency need to be calculated under different soil types for higher fertilizer use efficiency and avoidance of pollution risk.

2.6 Fertigation studies in sunflower

Application of fertigation in sunflower cultivation is a new practise and experimental findings are relatively scarce.

Urea at 120 kg N/ha applied in irrigation water to a commercial sunflower crop on a calcareous, cracking clay soil resulted in even distribution of applied N within the soil profile down to the bottom of plough layer and along the field in the direction of flow. At physiological maturity (76 days after fertilization 57 kg of N/ha was recovered in the plant tops and the bulk of this (42 kg) was in the grain. Based on these findings. Freney *et al.* (1985) suggests that although this method of application of fertilizer N is simple and cost effective, produces an even distribution of applied N across the field and reduces NH_3 loss, it still appears to be subject to substantial losses of N, presumably by denitrification, during subsequent irrigations.

Smith *et al.* (1988) studied nitrogen transformations and transfer after applying urea solution to a crop of sunflowers by ponding in furrows. The fertilizer was applied 24 days after sowing. This method of fertilizer application resulted in concentration of applied N in the furrow and shoulder zone of the soil beds; little of the applied N moved across the centre of the beds. A ^{15}N mass balance showed that 28 kg of the 80 kg N/ha applied (35%) was lost during the experiment at the rate of 4.6 kg/ha after each irrigation upto 44 days after fertilizer application. The

study indicated that N Loss could be markedly reduced by delaying the bulk of the application to coincide with the period of rapid uptake.

Sunflowers were trickle irrigated with municipal waste water or borewell water supplemented with nutrients. In 1985, seed yields were 4.15, 4.68, 4.41 and 4.59 t/ha with borehole water and 4.54, 4.62, 4.49 and 4.82 t with efficient at 0, 30, 60 and 90 mg N/litre irrigation water respectively. Corresponding yields for 1986 were 2.56, 2.68, 2.76 and 2.65 t/ha with borehole water and 2.83, 3.24, 3.21 and 2.96 with efficient. In 1987, 0, 15, 30 and 45 mg P/litre gave seed yields of 2.39, 2.54, 2.58 and 2.51 t respectively with borehole water and 2.60, 2.68, 2.66 and 2.46 t with effluent treatment (Papadopoulos and Stylianou, 1991).

From these studies it can be inferred that nitrogen losses are prominent in furrow fertigation. Synchronization of fertigation with the period of rapid uptake may serve as the best technique in achieving higher nutrient use efficiency. Effluent water can be applied to sunflower through trickle systems with good results. Further research is required to delineate various aspects of influence of fertigation on sunflower.

2.7, Effect of trickle fertigation on root distribution

Under trickle irrigation the spatial distribution of soil moisture and consequently crop roots is often restricted to a small volume of soil directly below the emitters. Such a restriction has important implications for optimum fertilizer placement. Furthermore, water is usually supplied in a cyclical fashion such that soil directly below the emitter can be saturated during irrigation cycles. Such a moisture regime can also greatly influence nutrient availability and root distribution. The size of the root system and its distribution pattern in a given soil are determined, to a great extent, by soil moisture content and distribution and their interaction with soil aeration and nutrient supply.

2.7.1, Capsicum

In a study comparing root distribution as influenced by fertigation, banded application of fertilizer + drip irrigation, broadcast fertilizer application + drip irrigation and a control treatment

Keng *et al.* (1979) found that dense fibrous root growth toward the nutrient and moisture source in fertigation and band placement. The fertilizer band also had more dry matter growth toward the fertilizer than away from the band. Drip irrigation encouraged the development of shallow root systems since it provided an adequate moisture and fertility conditions in the surface soil.

No roots were detected below a depth of 30 cm and at no greater lateral distance from the trickle nozzle than 30 cm at 155 days after sowing. About 80 per cent of the root system was located in the upper 20 cm under sprinkler and in the trickle plots, over 90 per cent of the roots were concentrated in the upper 20 cm layer and approximately 85 per cent of roots were within 20 cm of the nozzles. There was a concentration of fine roots close to the source of water (Goldberg *et al.* 1971).

Goyal *et al.* (1988) found that in all fertigation treatments under mulching, the root values were significantly higher for 0-11 cm soil depth than for other soil depths. More than 80 % of the roots were in 0-22 cm soil depth in all plots; this depth corresponded to the wetting zone under dripper.

2.7.2. Maize

In sweet corn cv. Jubilee, trickle irrigation with N, P and K given on the soil surface (S) or 30 cm below soil surface (SS) indicated that deep trickle placement increased P and K content at the centre of root zone. The enhanced concentration apparently stimulated plant rooting, which together with the higher nutrient activity in the soil solution, increased the P and K uptake rates. The higher root activity in SS than S fertigation was confirmed by soil air CO₂ concentration measurements which showed significant differences between the two treatment during the growing season (Martinez-Hernandez *et al.* 1991).

Phosphorus fertigation study by Phene *et al.* (1991) revealed that sweetcorn root extension continued at depths > 2 m. Roots in the top 45 cm soil depth showed greatest differences between S and SS treatment. Root length density was higher in the surface 30 cm in S plots and

below 30 cm in SS plots. Root density in the SS treatment was highest at 67 kg P/ha in SS plots, root length density decreased with increasing P rate.

In Piracicaba, Brazil maize cv. AG-529 was given a total of 120 kg N/ha at 23 and 47 d after emergence or fertigated with 4, 6, 45, 30 and 35 kg N/ha on 5 dates between 34 and 101 d after emergence. Application of N to the soil gave the highest root density in the upper 60 cm whereas fertigation gave the highest density in the 60-100 cm zone, with corresponding average grain yields of 4.52 t and 5.07 t/ha (Basso *et al.*, 1994).

In general, root growth under drip fertigation is highly dense in surface soil profile because of favourable nutrient, water and air balance. While, conventional irrigation and fertilization promote uniform root distribution with depth.

2.8 . Future of fertigation

The application of fertilizer through the irrigation systems (Fertigation) has become a common practice in modern irrigated agriculture. Increased yields, improvement in quality of the produce, irrigation and fertilizer use efficiencies and protection of the environment are some of the main characteristics of this method, which has made it very popular throughout the world. In some countries, introduction of fertigation can be regarded as a second 'Green revolution'. However, the correct method of application and transfer of technology to the farmers at their own level of grasp and adaptability is critical and of great importance (Papadopoulos, 1996). Microirrigation systems (MIS) form the basic requirement for successful fertigation. These technological innovations are to be exploited to achieve the main objectives of higher productivity and better water use efficiency.

Although micro or drip irrigation has revolutionized irrigated agriculture in many countries of the world and an accepted method of irrigation even in the developing countries. India has to embark on a massive program for popularizing this method. According to Sivanappan (1996) in spite of substantial economic and social advantages, the expected coverage of MIS has not been

reached due to institutional, political, financial and technical problems. The farmers are convinced about the usefulness of the system, but the adoption is very slow due to the high initial investment cost for the system. More than two million hectares are under drip irrigation for about 60 crops in the world, whereas in India, from literally no area under micro irrigation in the 1970's, it moved to 1000 ha in 1985 and to around 80,000 ha in 1995 feeding 20 crops of which 50,000 ha is in Maharashtra state alone followed by Tamil Nadu and Karnataka states. However, it is projected to have one million hectares under drip system in another 5-7 years, that is 1% of the irrigated area at that time in the country. Fertigation is well suited for these areas because of the availability of high grade 100% water soluble fertilizers. With substantial savings in both water as well as fertilizer, it is possible to increase the gross area by 2-3 times to that of net area provided water is available to take 2-3 crops in a year. This will solve many problems in the country including unemployment and foreign exchange by exporting vegetables, fruits and flowers in the coming years. The export potentialities of these crops and other commercial crops like tea, cashew, cardamom, pepper etc can be raised from the current levels of about Rs. 2500 crores to Rs. 4000 crores in a short time if drips and sprinklers are utilized in conjunction with the right and small amounts of fertilizer given through such irrigation treatment to the effective root zone.

The drip method is technically feasible, economically viable and socially acceptable. This method has recorded an increase in yield by 23-90% in various fruit and vegetable crops with water savings of about 40-77% as compared to conventional method (NCPA, 1990). Therefore, this method combined with fertigation can be adopted in the areas like (i) well irrigated areas which constitute about 35% of the irrigated area in the country (ii) it is ideally suited to all row crops especially coconut, fruit trees, vegetables, flowers, commercial crops, plantation crops etc. which occupy more than 18 m ha (iii) in waste lands by planting trees including fruit trees. More than 25 m ha is available in this category (iv) in hills and semi arid areas, coastal sand belts, water scarcity areas, command areas with community wells.

The plastic revolution on the one hand and the introduction of water soluble NPK fertilizers on the other, with Government of India's subsidy and incentives scheme in popularizing the micro-irrigation system fertigation assumes a key role in improving agricultural economy as well as ecosystem in the years to come (Shivashankar, 1996).

MATERIALS AND METHODS

III. MATERIAL AND METHODS

Details of the materials used and techniques adopted in the present investigation are described in this chapter.

3.1 Location

The experiment was carried out in plot numbers 12 and 13 of 'B' range of the Main Research Station, UAS, Hebbal, Bangalore during 1994-95 and 1996-97. The site is located at 12°58' North latitude and 77°37' East longitude and at an altitude of 899 m above mean sea level. The topography is fairly uniform with a gentle gradient towards North-West direction.

3.2 Soil characteristics

The experiment was conducted on red sandy loam soils. Before the initiation of experiment, composite soil samples from the experimental site were collected from 0 to 30 cm depth. These samples were air-dried, powdered and allowed to pass through 2 mm sieve and were analyzed for physical and chemical properties (Table-3.1). The soil was near neutral in reaction (pH 6.75) with 270 kg ha⁻¹ available N, 26.8 kg ha⁻¹ available P₂O₅ and 237 kg available K₂O ha⁻¹.

3.3 Climate

The data on climatic parameters such as rainfall, minimum and maximum temperature, mean relative humidity and mean daily evaporation recorded at MRS, Hebbal, Bangalore during experimental years and the mean of 10 years (1980-90) are presented in Table-3.2 and Figure 3.1.

The normal annual rainfall of the station is 819.2 mm. a major portion of which is received in May and between July and October months. Two peaks are observed (96.8 mm in May and 243.8 mm in September). The average pan evaporation ranges from 3.5 to 7.2 mm per day. Evaporation increases gradually from January to April and then it decreases.

Table-3.1 : Physical and chemical properties of soil of the experimental site, Main Research Station, Hebbal, Bangalore

Particulars	Value Soil depth (cm)			Method employed	Reference
	0-15	15-30	30-60		
I Mechanical Composition					
1. Coarse sand (%)	50.10	39.75		Hydrometer method	Piper, 1966
2. Fine sand (%)	27.36	29.66		Hydrometer method	Piper, 1966
3. Silt (%)	8.75	12.11		Hydrometer method	Piper, 1966
4. Clay (%)	12.99	20.29		Hydrometer method	Piper, 1966
5. Textural class	Red Sandy loam				
II Physical constants					
1. Field capacity (%)	14.03	16.20	16.40	Field method	Dastanc, 1967
2. Permanent Wilting Point (%)	8.05	10.65	12.59	Sunflower method	Dastanc, 1967
3. Available water (cm)	1.18	1.30	1.99	Gravimetric method	Dastanc, 1967
4. Bulk density (g/cc)	1.63	1.64	1.56	Core sampler method	Dastanc, 1967
III Chemical properties					
1. Soil pH	6.65	6.86		Buckman's pH meter	Piper, 1966
2. EC (m.mhos/cm)	0.16	0.18		Conductivity bridge	Jackson, 1973
3. Organic carbon (%)	0.35	0.39		Wet oxidation method	Jackson, 1973
4. Available N (kg/ha)	291.5	248.6		Modified Kjeldhal's method	Jackson, 1973
5. Available P ₂ O ₅ (kg/ha)	30.75	22.9		Bray's method	Muhr <i>et al.</i> 1965
6. Available K ₂ O (kg/ha)	248.5	225.6		Flame Photometer method	Muhr <i>et al.</i> 1965

A total rainfall of 676.1 mm and 847.9 mm was received during 1994-95 and 1996-97 respectively. The rainfall distribution was good during both the years. Peak rainfall of 159.0 and 227.1 mm received in June of 1994 and 1996 respectively was higher than the 10 year average rainfall (74.9 mm) which resulted in slight water logging situation leading to yellowing of capsicum crop. However, the crop recovered to some extent during subsequent growth period. The mean maximum and temperature during the crop growth period did not deviate much from the normal average values. Mean relative humidity in 1994-95 was 8 and 6 per cent higher in October and November than the normal relative humidity (72%) whereas in 1996-97 September and October

1989-90

Table-3.2 : Meteorological data indicating monthly normal (1989-90) and actual (1994-95 and 1996-97) weather parameters during crop growth period at Main Research Station, Hebbal, Bangalore

Months	1994-95						1996-97													
	Rainfall (mm)		Mean Max. Temp. (°C)		Mean Min. Temp. (°C)		Mean relative humidity (%)		Mean evaporation (mm)		Rainfall (mm)		Mean Max. Temp. (°C)		Mean Min. Temp. (°C)		Mean relative humidity (%)		Mean evaporation (mm)	
	N	A	N	A	N	A	N	A	N	A	N	A	N	A	N	A	N	A	N	A
May	-	-	-	-	-	-	-	-	-	-	96.8	32.0	33.9	34.9	20.8	21.7	61	78	6.9	7.3
Jun	74.9	29.0	30.7	29.7	20.4	20.2	72	72	5.5	6.1	74.9	227.1	30.7	29.5	20.4	20.5	72	74	5.5	4.7
Jul	94.6	97.9	29.8	28.0	19.9	20.1	74	71	5.3	5.1	94.6	45.0	29.8	29.3	19.9	20.3	74	71	5.3	5.6
Aug	102.0	159.0	28.3	28.5	19.6	19.9	76	67	4.4	4.8	102.0	181.7	28.3	28.2	19.6	19.8	76	76	4.4	4.6
Sep	243.8	112.1	28.6	29.8	19.5	19.5	76	72	4.2	5.3	243.8	190.5	29.6	28.0	19.5	19.9	76	81	4.2	4.1
Oct	85.0	79.7	28.4	28.2	18.8	19.5	72	80	4.2	3.4	85.0	95.7	28.4	27.3	18.0	19.0	72	79	4.2	3.7
Nov	43.1	18.7	26.9	25.5	16.8	17.1	72	78	3.5	3.1	43.1	2.4	26.9	26.1	16.8	19.4	72	72	3.5	3.7
Dec	12.2	1.9	26.3	26.1	15.6	13.9	70	67	3.8	3.8	12.2	14.7	26.3	25.0	15.6	15.0	70	72	3.8	3.4
Jan	5.1	19.8	27.3	26.9	14.7	15.7	67	68	4.6	4.0	5.1	1.3	27.3	27.0	14.7	15.3	67	67	4.6	4.2
Feb	11.7	0.0	29.4	30.6	15.9	16.8	62	59	5.6	5.6	11.7	0.0	29.4	30.6	15.9	15.2	62	59	5.6	5.7
Mar	20.1	56.8	32.5	32.8	18.4	17.6	56	53	7.0	7.1	20.1	20.5	32.5	32.7	18.4	17.6	56	57	7.0	7.1
Apr	29.9	4.3	34.1	34.1	21.3	21.5	57	54	7.2	7.3	29.9	37.0	34.1	32.7	21.3	20.1	57	58	7.2	6.4
May	96.8	96.9	33.9	32.1	20.8	21.4	61	67	6.9	6.2	-	-	-	-	-	-	-	-	-	-

N = Normal

A = Actual

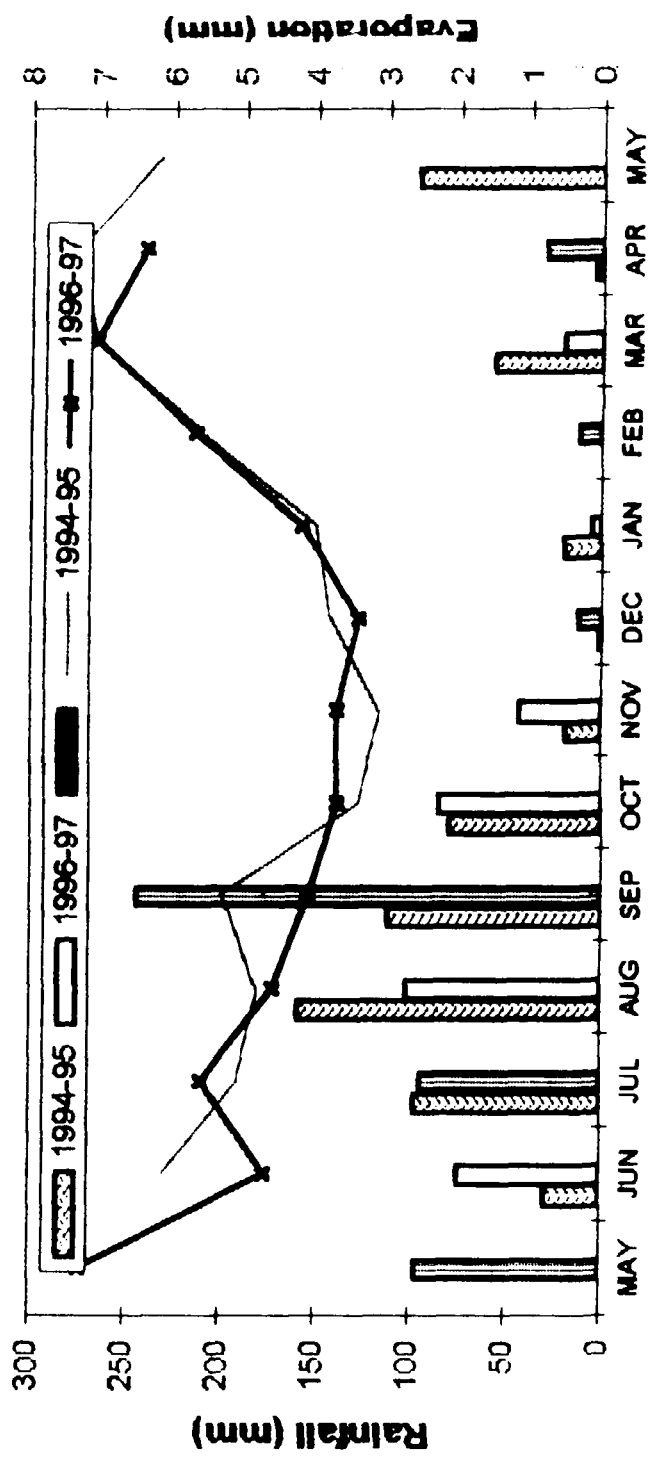

Fig. 3.1 : Total monthly rainfall and mean daily evaporation at Main Research Station, Hebbal during experimental period.

months had 5 and 7 per cent higher relative humidity than the normal values (76 and 72% respectively). The pan evaporation ranged from 3.1 – 7.3 mm and 3.4 – 7.3 mm per day, respectively during 1994-95 and 1996-97. Maximum evaporation of 7.3 mm/day was observed in April, 1994 and May, 1996. Thus both the years were favorable for crop growth resulting in satisfactory yield.

3.4 Land preparation of the experimental area

The plot was kept fallow during the preceding season before taking up the present investigation. However, the crop raised during the previous kharif (1993) was tomato. Before the commencement of each crop, the furrow-irrigation plots were thoroughly ploughed once followed by harrowing twice and the fertigation plots were hand dug and harrowed. A fine seedbed was prepared for sowing maize and sunflower. In case of capsicum, nursery was raised as per standard practice.

3.5 Experimental details

Experiments on capsicum-maize-sunflower sequence were conducted for two alternate kharif, rabi and summer seasons during 1994-95 and 1996-97. After the completion of the first sequence, the experiment could not be continued successively because of severe bacterial wilt on capsicum. So the experiment was continued during 1996-97. The details of the experiment are presented in Table-3.3.

3.5.1 Salient features of the varieties

- a) **Capsicum : Var. Arka Gaurav.** The plants are indeterminate, bearing upright fruits, 3-4 lobed; green blocky. The flesh is thick, juicy and non-pungent. This prolific bearer variety from Indian Institute of Horticultural Research, Bangalore produces 10-12 tons of fresh fruits per hectare in 100-120 days.

Table-3.3 : Details of the experiment

Particulars	Description												
Title	Effect of fertigation with watersoluble and normal fertilizers compared to drip and furrow systems in Capsicum-Maize-Sunflower cropping sequence.												
Cultivars	Capsicum - Arka Gaurav Maize - Deccan Hybrid Sunflower - KBSH-1												
Design	Split-split plot design												
Replications	Three												
Treatments	A. <u>Main Plot (Irrigation methods)</u> I ₁ - Furrow irrigation I ₂ - Drip irrigation I ₃ - Fertigation B. <u>Sub plot (Fertilizer levels)</u> L ₁ = 80% Recommended dose L ₂ = 100% Recommended dose C. <u>Sub-Sub plot (Fertilizer source)</u> S ₁ = Normal Fertilizer (NF) S ₂ = Water Soluble Fertilizer (WSF)												
Plot size	Gross - 6 m x 4 m Net - 4 m x 2.8 m												
Plan of layout	Figure 3.2												
Spacing	60 cm x 30 cm (Common for all crops)												
Irrigation System	Consists of borewell water source, fertigation tank, sand filter, mesh filter, main, sub, lateral lines with perforated biwall tape as a line source, control valves for each plot.												
Fertilizer N:P ₂ O ₅ :K ₂ O kg ha ⁻¹	Capsicum Maize Sunflower 150:75:50 150:75:50 63:75:63												
Fertilizer sources	<u>Normal Fertilizer</u> : Urea, superphosphate, muriate of potash <u>Water soluble fertilizer</u> : 100% soluble NPK complex Grade 30:10:10 and 19:19:19 'Ferticare' brand supplied by Kemira Agro OY Finland.												
Crop period	<table style="width:100%; border:none;"> <thead> <tr> <th></th> <th style="text-align:center;">1994-95</th> <th style="text-align:center;">1996-97</th> </tr> </thead> <tbody> <tr> <td>Capsicum</td> <td>12.6.94 to 8.10.94(118 days)</td> <td>20.5.96 to 12.9.96 (115 days)</td> </tr> <tr> <td>Maize</td> <td>18.10.94 to 8.2.95(112 days)</td> <td>16.9.96 to 4.1.97(110 days)</td> </tr> <tr> <td>Sunflower</td> <td>20.2.95 to 26.5.95(95 days)</td> <td>12.1.97 to 22.4.97(100 days)</td> </tr> </tbody> </table>		1994-95	1996-97	Capsicum	12.6.94 to 8.10.94(118 days)	20.5.96 to 12.9.96 (115 days)	Maize	18.10.94 to 8.2.95(112 days)	16.9.96 to 4.1.97(110 days)	Sunflower	20.2.95 to 26.5.95(95 days)	12.1.97 to 22.4.97(100 days)
	1994-95	1996-97											
Capsicum	12.6.94 to 8.10.94(118 days)	20.5.96 to 12.9.96 (115 days)											
Maize	18.10.94 to 8.2.95(112 days)	16.9.96 to 4.1.97(110 days)											
Sunflower	20.2.95 to 26.5.95(95 days)	12.1.97 to 22.4.97(100 days)											

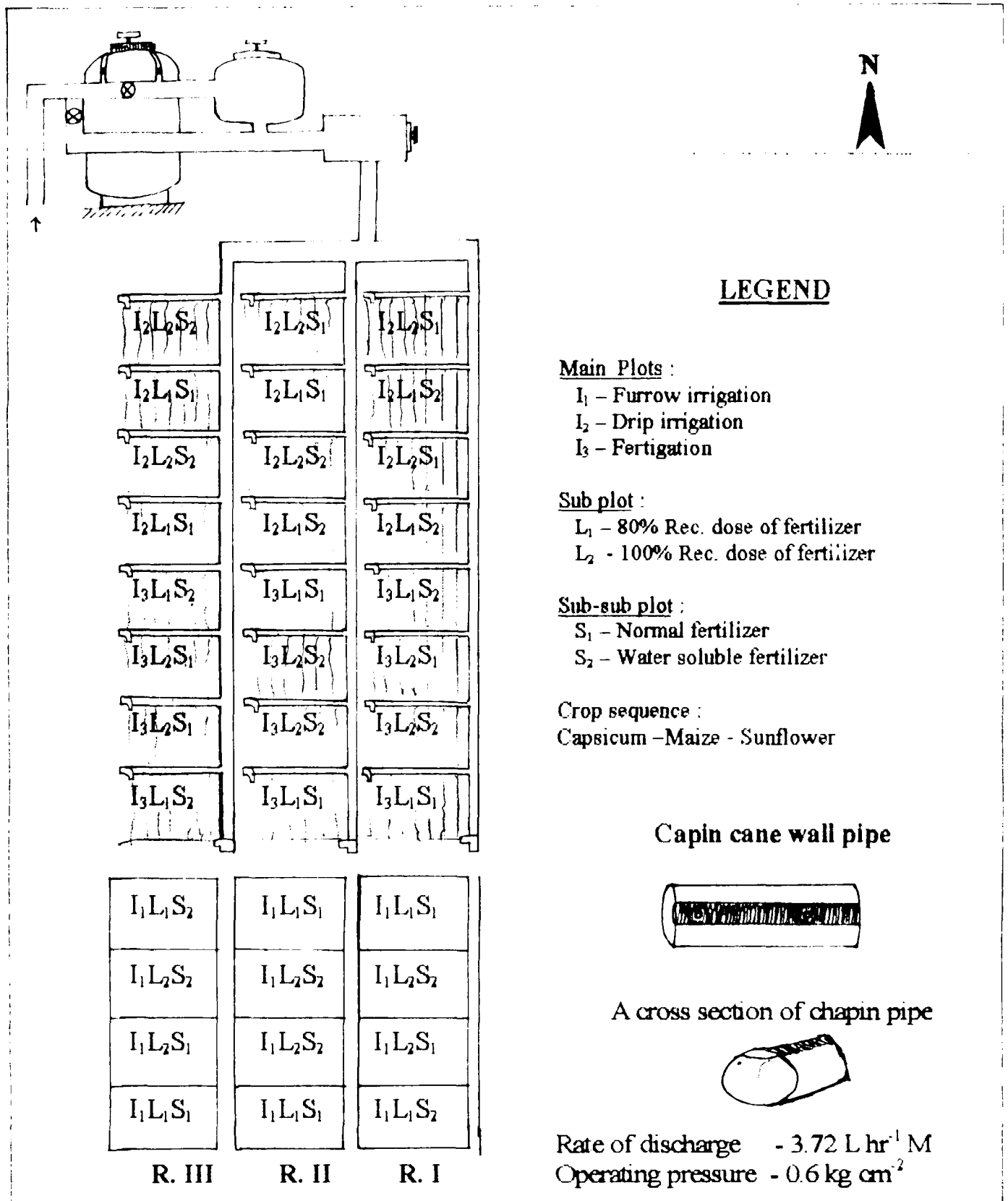

Fig. 3.2: Plan of layout and schematic diagram of drip irrigation system

- b) **Maize : Deccan Hybrid.** A progeny of double cross between CM 104 x CM 105 and CM 202 x CM 201, matures in 100-110 days yielding about 55-60 q ha⁻¹. The crop grows to a height of 250-300 cm, the stems are thick, stained with reddish color at the base. The grains are bold flinty, bright yellow in color covered with tight husk. This variety is highly resistant to downy mildew, leaf blight and rust. Besides, it is fairly tolerant to top shoot borer and bacterial stalk rot.
- c) **Sunflower : KBSH-1.** Released during 1992 as a hybrid (CM 234A x RHA 6D-1) resistant to rust and downy mildew diseases. Grows to a height of 120-150 cm maturing in 90-95 days. The crop yields about 15 quintals per ha normally and potentiality is about 20-25 quintals. It contains 42-44 per cent oil and is recommended for cultivation in sunflower growing areas of the country.

3.6 Cultural operations

3.6.1 Irrigation

3.6.1.1 Installation of drip unit

The drip unit consisted of four stage filter system with a mesh of 100 and 80 microns, fertilizer tank, water meter, control valve for each plot, air exhaust valve and pressure gauge of 5.0 cm diameter attached in series to the main line. The system continued into submain (2.5 cm dia) and biwalled pipe perforated at every 30 cm as a line source lateral emitter. The water source was from a borewell to which the main pipe was connected with a flush valve prior to the fertigation set up in order to allow only optimum pressure flow so that the emitters located at different points on the laterals deliver uniform discharge.

3.6.1.2 Irrigation schedule

In furrow irrigated plots, irrigation was done once in eight days as per farmer's practice. The drip and fertigation plots received daily replenishment of 100% of evaporation losses from USWB Class I Open Pan Evaporimeter. Water was measured by a water meter (aquameter) of

1.5" size and conveyed through the pipelines/channels. Quantity of water applied for each crop is presented in Table-3.4.

3.6.2 Fertilizer application

In furrow and drip irrigation plots fertilizers were soil applied in the form of urea, superphosphate and muriate of potash or 100% water soluble complex as per the treatment. Urea was used for top dressing.

In case of fertigated plots, requisite quantity of 100% water soluble fertilizer 'ferticare' grade 30:10:10 and 19:19:19 supplied by Kemira Agro, Finland was mixed with water in fertigation tank and allowed with irrigation. When normal fertilizer (i.e. Urea, superphosphate and muriate of potash) were used for fertigation, the solution was pre-filtered and put into fertigation tank. Detailed fertigation schedule followed for individual crops is presented in Table-3.5.

3.6.3 After care

Inter cultivation at 15 and 30 DAS and one hand weeding at 30-35 days were followed for all crops. During the second inter cultivation, earthing up was done to each plant row. Incidence of bacterial wilt at early vegetative stage and mosaic leaf curl at later stages was noticed during both the years on capsicum. As a precautionary measure, experimental plots were drenched with bleaching powder (20 kg ha^{-1}) in water for the second crop of capsicum.

3.7 Harvesting and threshing

Green fruits were harvested from capsicum periodically as the fruits attained marketable size. Maize and sunflower crops were harvested when they reached maturity. During harvest, border plants were first removed from the plot. Then net plot crop was harvested and dried under sun for a period of one week. Dried materials were hands threshed to separate grains. Later on, grain was air dried and bagged to record yield and yield parameters.



Plate 3.1 - General view of the experimental plot



Plate 3.2 - Wetting pattern under Chapin pipe



Plate 3.3 - Fertigation tank with sand and mesh filters



Plate 3.4 - Kemira 100% Water Soluble Fertilizers

Table 3.4 Quantity of irrigation water applied during the experimental period

Treatments	Irrigation water (M ³ / ha)					
	Capsicum		Maize		Sunflower	
	1994	1996	1994	1996	1995	1997
Furrow	5904	5043	4500	4768	7265	6980
Drip and fertigation	4638	3946	3510	3725	5560	5367

Table – 3.5 Fertilizer application schedule

Treatments	Capsicum	Maize	Sunflower
Furrow and Drip* (soil application of fertilizer)	50% N, full P & K as basal dose 25% N at 4 WAP	25% N, full P & K as basal dose 25% N at 4 WAS 25% N at 6 WAS	50% N, Full P & K as basal dose 50% N at 4 WAS
Fertigation (Fertilizer through irrigation)	8 fertigations of biweekly equal dose at 2, 16, 30, 44, 58, 72, 86, 100 DAP	7 fertigations of biweekly equal dose at 5, 19, 33, 47, 61, 75, 86 DAS	6 fertigations of biweekly equal dose at 5, 18, 33, 47, 61, 75 DAS

DAS =Days after sowing DAP = Days after planting WAS = Weeks after sowing
WAP = Weeks after planting *As per recommended package

3.8 Collection of experimental data and plant sampling procedure.

3.8.1 Studies on growth, yield and quality characters

For recording various biometric observations in both the years, a sample consisting of five plants was selected at random from each net plot. Observations on various growth, yield and

quality parameters were made in all the samples at different stages of crop growth (30, 60, 90 DAS and at harvest). All parameters and procedures followed to record the observations are presented in Table-3.6.

3.8.2 Soil moisture studies

Soil samples were taken from 0-10, 10-20 and 20-30 cm depths 24 hours after irrigation in 1994 and 1996 to determine moisture gravimetrically after oven drying the samples at 105°C to a constant weight.

3.8.3 Root distribution studies

Root study was carried out after each harvest using small core sampler (length 10.5 cm and inner dia meter 5.3 cm). Root plus soil samples were collected by driving the core sampler besides the representative plants at three depths i.e. 0-10 cm, 10-20 cm. Rootlets were extracted by immersing the soil cores in water and root dry weight was expressed as grams per plant.

3.8.4 Residual nutrient distribution studies

Soil samples were collected before the beginning of experiment and analyzed for initial soil NO₃-N, extractable P and exchangeable K. Soil depths considered for the study were 0-15, 15-30, 30-45 and 45-60 cm. After every harvest, treatmentwise soil analysis was carried out treatmentwise as per standard procedure.

Table-3.6 : Method of recording observations on different parameters

Particulars	Procedure followed
I Growth components	
Plant height (cm)	Height from base of the plant to the tip of the main shoot/tassel/capitulum
Stem girth (cm)	Girth of the stem just below the first basal node by using calipers
No. of branches (plant ⁻¹)	Number of primary and secondary branches at final picking (Capsicum)
No. of green leaves (plant ⁻¹)	Number of fully opened green leaves borne on main stem at 60 DAS
Leaf area (cm ² plant ⁻¹) (Vivekanandan <i>et al.</i> , 1972) ✓	Leaf area was worked out by disc method on dry weight basis
Leaf area index (LAI) (Sestak <i>et al.</i> 1971) ✓	$LAI = \frac{\text{Leaf area plant}^{-1} (\text{cm}^2)}{\text{Land area plant}^{-1} (\text{cm}^2)}$
Dry matter production (g plant ⁻¹)	Oven dry weight (drying at 70°C to a constant weight) of different parts was recorded after partitioning stem, leaf and fruit/cob/head at different crop growth stages (30, 60, 90 DAS and at harvest). The sum of mean dry weight of all the plant parts represents total dry matter plant ⁻¹ (g).
50% Tasselling/silking/flowering	Counting the plants with tassels/silk/flower once in two days till 50 per cent of the total plants in the plot attained tassel/silk/flowering.
II. Yield and yield component	
A. Capsicum	
Green fruit yield (g plant ⁻¹ , kg ha ⁻¹)	Fresh weight of green fruits harvested at different pickings from labelled plants was recorded. The green fruit yield ha ⁻¹ was estimated based on yield obtained from net plot area.
No. of green fruits (plant ⁻¹)	No. of fruits harvested from labelled plants at each picking.
Length and girth of green fruits (cm)	Mean length and girth of five randomly selected fruits from labelled plant in each picking.
B. Maize	
Grain yield (g cob ⁻¹ , kg ha ⁻¹)	Mean weight of grains from sample cobs was recorded. Grain yield in kg ha ⁻¹ computed from grain obtained from each net plot.
Stover yield (kg ha ⁻¹)	Plants separated from cobs were sun dried plotwise. Weight of stover recorded and converted into kg ha ⁻¹ values.
Grain No. row ⁻¹ , cob ⁻¹	Counting No. of grains in two rows of each cob at random and grains of five individual cobs threshed separately to record mean No. of grains cob ⁻¹ .
Thousand grain weight (g)	Weight of 1000-grains randomly selected from net plot yield.
Shelling percentage	$\text{Shelling percentage} = \frac{\text{Grain weight per plot}}{\text{Cob weight per plot}} \times 100$

Contd.

Table-3.6 : Method of recording observations on different parameters (Contd..)

Cob length and girth (cm)	Mean length and girth of five cobs from labelled plants
Prolificity per cent	$\text{Prolificity per cent} = \frac{\text{No. of plants with double cob in net plot}}{\text{Total plants harvested in net plot}} \times 100$
C. Sunflower	
Seed yield plant ⁻¹ , kg ha ⁻¹	Mean weight of seeds from labelled plants was recorded; seed yield in kg ha ⁻¹ computed from each net plot yield
Stalk yield kg ha ⁻¹	Weight of sun dried plants in each plot after separating head, expressed as kg ha ⁻¹
Diameter of head (cm)	Distance between two diametrically opposite sides of the capitulum.
No. of seeds plant ⁻¹ , No. of filled seeds plant ⁻¹	Number of well filled seeds and total number of seeds (filled + unfilled) of five randomly selected heads.
Filling per cent	$\text{Filling per cent} = \frac{\text{No. of filled seeds head}^{-1}}{\text{Total No. of seeds head}^{-1}} \times 100$
Threshing per cent	$\text{Threshing per cent} = \frac{\text{Seed weight g plant}^{-1}}{\text{Head weight g plant}^{-1}} \times 100$
Husk per cent	$\text{Husk per cent} = \frac{\text{Weight of husk of 50 seeds}}{\text{Weight of kernels of 50 of seeds}} \times 100$
III Quality studies	
A. Capsicum	
Ascorbic acid content (mg/100 g green fruit) (Bessay and King, 1933)	Titration involving 2-6-Dichlorophenol-indophenol as reducing solvent.
B. Sunflower	
Oil content (%) and oil yield (kg ha ⁻¹)	By nuclear magnetic resonance spectrometer (NMR model minispec-20p). The oil yield was calculated from the oil content multiplied with seed yield.
IV. Chemical analysis	
Total Nitrogen (N) (%) (Jackson, 1973)	Total nitrogen content on dry weight basis at harvest by modified Kjeldahl's method.
Phosphorus(P) content (%) (Jackson, 1973 ¹)	Phosphorus content on dry weight basis at harvest by Vanado molybdo-phosphoric yellow colour method.
Potassium (K) content(%) (Jackson, 1973)	Potassium content on dry weight basis at harvest by Flame Photometer method.
N, P and K uptake kg ha ⁻¹	The concentration of N, P ₂ O ₅ and K ₂ O was multiplied with the total dry matter at harvest to obtain uptake of N, P ₂ O ₅ and K ₂ O respectively and expressed as kg ha ⁻¹

Contd..

Table-3.6 : Method of recording observations on different parameters (Contd.)

V. Assessment of efficiency	
Irrigation water use efficiency (IWUE) (Kg yield M ³)	$IWUE = \frac{\text{Economic yield kg ha}^{-1}}{\text{Amount of irrigation water applied M}^3}$
Fertilizer use efficiency (FUE) (Kg yield kg ⁻¹ NPK)	$FUE = \frac{\text{Economic yield kg ha}^{-1}}{\text{Total NPK fertilizer applied kg ha}^{-1}}$
VI. Economic analysis	
Net returns (Rs. ha ⁻¹)	Net returns was obtained by deducting cost of cultivation from gross income
Cost : Benefit ratio (B.C. ratio)	$C.B.\text{ratio} = \frac{\text{Net returns (Rs. ha}^{-1}\text{)}}{\text{Total cost of cultivation (Rs. ha}^{-1}\text{)}}$

3.9 Statistical analysis and interpretation of data

The data recorded on various characters were subjected to Fisher's method of analysis of variance and interpretation of data as given by Gomez and Gomez (1984). The level of significance used in 'F' and 't' tests was P = 0.05. Least significant difference (LSD) values were calculated whenever the 'F' was found significant.

EXPERIMENTAL RESULTS

IV. EXPERIMENTAL RESULTS

Results of the field experiment “ Effect of fertigation with normal and water soluble fertilizers compared to drip and furrow systems in Capsicum - Maize - Sunflower cropping sequence” conducted during 1994-95 and 1996-97 at the University of Agricultural Sciences, Bangalore are presented in this chapter.

4.1 Growth components of capsicum

4.1.1 Plant height of capsicum (cm)

Data on plant height of capsicum recorded at 30, 60 and 90 days after planting (DAP) are presented in Table-4.1.

Irrigation methods had significant influence on plant height at all growth stages except at 30 DAP in 1996. Plant height under fertigation and drip was significantly higher than under furrow method. Maximum plant height was recorded when fertigation was employed (16.95 – 33.07 cm) at different stages of crop growth. Shortest plants were observed with furrow irrigation (14.41 – 28.42 cm).

Between the fertilizer levels, 100% recommended dose was significantly superior in plant height than the 80% recommended dose during 60 and 90 DAP stages in 1996. However, the plant height did not differ due to reduced fertilizer level in rest of the stages.

There were no significant differences between fertilizer sources and the interaction effects were also absent among irrigation methods, levels and sources of fertilizer.

Table-4.1 : Plant height in capsicum as influenced by methods of irrigation, levels and sources of fertilizer during 1994 and 1996

Treatments	Plant height (cm)					
	30 DAP		60 DAP		90 DAP	
	1994	1996	1994	1996	1994	1996
<u>Main treatments</u>						
<u>Irrigation methods</u>						
I ₁ Furrow	14.41	15.03	22.83	23.23	27.42	28.42
I ₂ Drip	16.13	16.62	25.72	25.72	30.00	29.32
I ₃ Fertigation	16.95	17.00	27.71	27.25	33.07	32.17
F test	*	NS	*	*	*	*
C.D at 5%	1.94	-	2.78	1.87	2.31	1.96
<u>Fertilizer levels</u>						
L ₁ 80% Rec. dose	15.56	15.84	24.93	24.56	29.19	29.07
L ₂ 100% Rec. dose	15.92	16.59	25.91	26.22	31.13	30.88
F test	NS	NS	NS	*	NS	*
C.D at 5%	-	-	-	0.71	-	1.62
<u>Fertilizer sources</u>						
S ₁ NF	15.84	16.32	25.58	25.30	29.58	29.54
S ₂ WSF	15.69	16.11	25.26	25.50	30.75	30.41
F test	NS	NS	NS	NS	NS	NS
C.D at 5%	-	-	-	-	-	-
<u>Combined treatments</u>						
<u>Furrow irrigation</u>						
T ₁ 80% Rec. dose NF	13.97	14.97	22.23	22.13	26.27	27.57
T ₂ 80% Rec. dose WSF	14.27	15.57	23.30	22.87	27.17	26.83
T ₃ 100% Rec. dose NF	14.07	15.34	21.73	24.20	28.20	27.90
T ₄ 100% Rec. dose WSF	14.27	14.23	24.07	23.73	28.06	31.37
<u>Drip irrigation</u>						
T ₅ 80% Rec. dose NF	15.93	16.27	26.88	24.90	25.87	28.37
T ₆ 80% Rec. dose WSF	16.30	15.80	23.73	24.83	31.17	29.23
T ₇ 100% Rec. dose NF	16.47	16.73	27.20	26.87	31.20	29.63
T ₈ 100% Rec. dose WSF	15.83	17.67	25.07	26.27	31.77	30.07
<u>Fertigation</u>						
T ₉ 80% Rec. dose NF	16.71	16.63	26.17	26.37	32.40	31.03
T ₁₀ 80% Rec. dose WSF	16.13	15.80	26.27	26.37	32.27	31.37
T ₁₁ 100% Rec. dose NF	17.88	17.89	27.27	27.33	33.53	32.73
T ₁₂ 100% Rec. dose WSF	17.03	17.60	28.13	28.93	34.07	33.57
F test	NS	NS	NS	NS	NS	NS
C.D. at 5%	-	-	-	-	-	-

Rec. Dose=150:75:50kg N:P₂O₅:K₂O/ha
DAP = Days after planting

* = Significant
NS = Non-significant

NF = Normal fertilizer
WSF = Water soluble fertilizer

4.1.2 Leaf area in capsicum

Leaf area in capsicum as influenced by irrigation methods, levels and sources of fertilizer was recorded at 30, 60 and 90 DAP (Table-4.2).

Different methods of irrigation caused significant differences in leaf area during all growth stages except 30 DAP in 1994. The highest leaf area was recorded with fertigated capsicum (258-412 cm²) at all stages. Drip irrigation was also significantly superior to furrow method but was on par with fertigation (231-394 cm²). Lowest leaf area was registered with furrow irrigation (231-336 cm²) throughout different growth stages (Fig. 4.1).

The leaf area in capsicum was not significantly influenced by either levels or sources of fertilizers except at 30 DAP in 1996 wherein 100% dose resulted in significantly higher leaf area of 262.7 cm² than 80% dose (246.6 cm²). Water soluble fertilizer registered numerically higher leaf area (243 to 380 cm²) as compared to normal fertilizer (225 to 382 cm²).

With regard to interaction between different factors, fertigation with water soluble fertilizer at 100% recommended dose produced the highest leaf area at all the observations (413 to 434 cm²/plant at 90 DAS) compared to same level with furrow irrigation (318 to 332 cm²/plant) although statistically non-significant.

4.1.3 Number of leaves per plant in capsicum

Data on number of leaves recorded at 60 DAS per plant as influenced by methods of irrigation, levels and sources of fertilizer are furnished in Table-4.3.

Highest number of leaves at 60 DAP was observed in the crop that received fertigation treatment in both the years 1994 and 1996 (68.4 and 67.6 respectively) but it was on par with drip irrigation (61.4 and 64.9 respectively). Furrow irrigated plants had lower number of leaves (54.5 and 58.7) per plant as compared to drip or fertigation.

Table-4.2 : Leaf area in capsicum as influenced by methods of irrigation, levels and sources of fertilizer during 1994 and 1996

Treatments	Leaf area(cm ²)					
	30 DAP		60 DAP		90 DAP	
	1994	1996	1994	1996	1994	1996
Main treatments						
Irrigation methods						
I ₁ Furrow	212.70	224.53	258.31	271.30	313.57	336.81
I ₂ Drip	231.89	260.17	316.91	342.10	373.53	394.03
I ₃ Fertigation	258.94	279.31	343.68	355.75	408.24	412.72
F test	NS	*	*	*	*	*
C.D at 5%	-	30.49	23.07	37.78	55.68	48.29
Fertilizer levels						
L ₁ 80% Rec. dose	226.97	246.63	299.53	315.67	357.76	367.50
L ₂ 100% Rec. dose	242.07	262.71	313.08	330.47	372.47	394.87
F test	NS	*	NS	NS	NS	NS
C.D at 5%	-	19.01	-	-	-	-
Fertilizer sources						
S ₁ NF	225.73	256.97	301.89	320.04	363.87	382.34
S ₂ WSF	243.29	251.37	310.72	326.01	366.36	380.04
F test	NS	NS	NS	NS	NS	NS
C.D at 5%	-	-	-	-	-	-
Combined treatments						
Furrow irrigation						
T ₁ 80% Rec. dose NF	190.15	214.74	258.46	266.25	311.26	343.59
T ₂ 80% Rec. dose WSF	217.14	208.36	248.15	274.83	294.28	312.61
T ₃ 100% Rec. dose NF	215.26	244.19	251.35	280.76	330.24	356.51
T ₄ 100% Rec. dose WSF	228.25	230.83	269.30	263.36	318.30	334.52
Drip irrigation						
T ₅ 80% Rec. dose NF	212.15	261.26	309.08	323.58	371.18	365.44
T ₆ 80% Rec. dose WSF	241.92	250.15	318.17	340.35	372.24	395.54
T ₇ 100% Rec. dose NF	229.36	270.94	311.19	353.71	363.18	409.67
T ₈ 100% Rec. dose WSF	244.15	258.33	327.22	350.77	387.54	405.68
Fertigation						
T ₉ 80% Rec. dose NF	242.23	266.52	322.10	337.80	385.17	390.25
T ₁₀ 80% Rec. dose WSF	257.15	278.74	341.22	351.32	412.22	397.58
T ₁₁ 100% Rec. dose NF	264.22	284.18	353.16	358.16	422.21	428.57
T ₁₂ 100% Rec. dose WSF	271.16	287.79	358.24	375.72	413.36	434.49
F test	NS	NS	NS	NS	NS	NS
C.D. at 5%	-	-	-	-	-	-

Rec. Dose=150:75:50kg N:P₂O₅:K₂O/ha
DAP = Days after planting

* = Significant
NS = Non-significant

NF = Normal fertilizer
WSF = Water soluble fertilizer

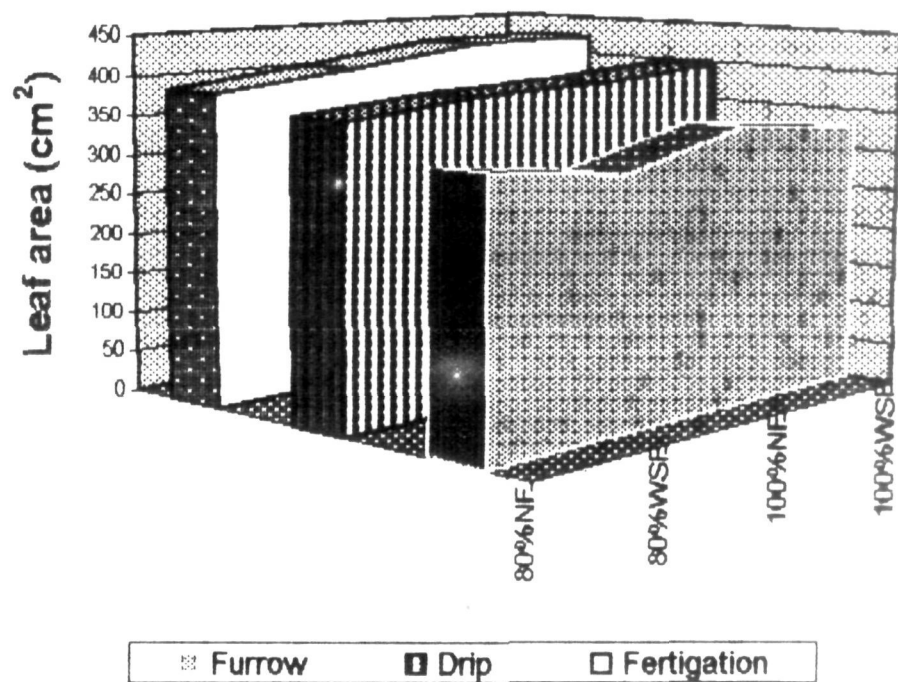

Fig. 4.1 : Leaf area in capsicum as influenced by fertigation, drip and furrow with levels and sources of fertilizer (mean of two years)

Table-4.3 : Number of leaves per plant in capsicum at 60 days after planting as influenced by methods of irrigation, levels and sources of fertilizer during 1994 and 1996

Treatments	Number of leaves/plant							
	1994			1996				
	80% Rec. dose (L ₁)	100% Rec. dose (L ₂)	Mean	80% Rec. dose (L ₁)	100% Rec. dose (L ₂)	Mean		
Main treatments								
Irrigation methods								
I ₁ Furrow	53.10	56.02	54.56	56.82	60.53	58.68		
I ₂ Drip	59.79	63.04	61.42	63.64	66.26	64.95		
I ₃ Fertigation	66.98	69.75	68.37	66.89	68.26	67.59		
Mean	59.96	62.94		62.45	65.02			
Fertilizer sources								
S ₁ NF	59.14	62.63	60.88	62.57	64.52	63.54		
S ₂ WSF	60.78	63.24	62.01	62.34	65.53	63.93		
Mean	59.96	62.94		62.45	65.02			
Irrigation methods								
I ₁ Furrow	NF(S ₁)	WSF(S ₂)	54.95	54.17	54.56	58.44	58.91	58.68
I ₂ Drip			60.33	62.50	61.42	64.58	65.31	64.95
I ₃ Fertigation			67.37	69.36	68.37	67.60	67.58	67.59
Mean			60.88	62.01		63.54	63.93	
F-test								
I	*	7.57		*	6.12			
L	NS	-		NS	-			
S	NS	-		NS	-			
I x L	NS	-		NS	-			
L x S	NS	-		NS	-			
I x S	NS	-		NS	-			
I x L x S	NS	-		NS	-			

Rec. Dose=150:75:50kg N:P₂O₅:K₂O/ha
DAP = Days after planting

* = Significant
NS = Non-significant

NF = Normal fertilizer
WSF = Water soluble fertilizer

Recommended dose of fertilizer (100%) or WSF source did not significantly influence number of leaves as compared to lower dose (80%) or NF source in both the years 1994 and 1996. Interactions were also absent.

4.1.4 Leaf Area Index (LAI) in capsicum

The data on leaf area index (LAI) in capsicum as influenced by methods of irrigation, levels and sources of fertilizer are presented in Table-4.4.

Significantly higher LAI (0.14-0.23) was recorded in fertigation treatment at all growth stages except 30 DAP in 1996 than furrow irrigation (0.12-0.19) but was on par with drip irrigation (0.13-0.21) (Table-4.4). Between the levels of fertilizer, higher LAI (0.14-0.22) recorded with 100% recommended dose was not statistically significant to the LAI (0.12-0.22) obtained with the reduced dose (80%) during three stages of crop growth in both the years 1994 and 1996.

Differences in LAI due to sources of fertilizer were not significant. Similarly interaction among various treatments did not evince significant influence on LAI at any stage.

4.1.5 Total dry matter in capsicum

The data on total dry matter of biomass (g plant^{-1}) as influenced by irrigation methods, levels and sources of fertilizer at 30, 60, 90 DAP and harvest are presented in Table-4.5.

Total dry weight of plant increased progressively as the age advanced from 30 DAP upto harvest. Fertigation treatment produced significantly higher dry matter at all stages barring 30 DAP in 1994 and it varied from 1.8 to 19.92 g per plant. Corresponding values for drip method

Table-4.4 : Leaf area index in capsicum as influenced by methods of irrigation, levels and sources of fertilizer during 1994 and 1996

Treatments	Leaf Area Index (LAI)					
	30 DAP		60 DAP		90 DAP	
	1994	1996	1994	1996	1994	1996
Main treatments						
Irrigation methods						
I ₁ Furrow	0.12	0.13	0.14	0.15	0.17	0.19
I ₂ Drip	0.13	0.14	0.17	0.19	0.21	0.21
I ₃ Fertigation	0.14	0.15	0.19	0.20	0.22	0.23
F test	*	NS	*	*	*	*
C.D at 5%	0.01	-	0.03	0.03	0.03	0.02
Fertilizer levels						
L ₁ 80% Rec. dose	0.12	0.14	0.17	0.17	0.20	0.20
L ₂ 100% Rec. dose	0.14	0.15	0.17	0.18	0.20	0.22
F test	NS	NS	NS	NS	NS	NS
C.D at 5%	-	-	-	-	-	-
Fertilizer sources						
S ₁ NF	0.13	0.14	0.16	0.18	0.20	0.21
S ₂ WSF	0.13	0.14	0.17	0.18	0.20	0.21
F test	NS	NS	NS	NS	NS	NS
C.D at 5%	-	-	-	-	-	-
Combined treatments						
Furrow irrigation						
T ₁ 80% Rec. dose NF	0.11	0.12	0.14	0.15	0.17	0.19
T ₂ 80% Rec. dose WSF	0.12	0.12	0.14	0.15	0.16	0.17
T ₃ 100% Rec. dose NF	0.12	0.14	0.14	0.16	0.18	0.20
T ₄ 100% Rec. dose WSF	0.13	0.13	0.15	0.15	0.18	0.19
Drip irrigation						
T ₅ 80% Rec. dose NF	0.12	0.14	0.17	0.18	0.21	0.20
T ₆ 80% Rec. dose WSF	0.13	0.14	0.18	0.19	0.21	0.22
T ₇ 100% Rec. dose NF	0.13	0.15	0.17	0.20	0.20	0.22
T ₈ 100% Rec. dose WSF	0.14	0.14	0.18	0.19	0.20	0.22
Fertigation						
T ₉ 80% Rec. dose NF	0.13	0.15	0.18	0.19	0.21	0.22
T ₁₀ 80% Rec. dose WSF	0.14	0.15	0.19	0.19	0.23	0.22
T ₁₁ 100% Rec. dose NF	0.15	0.16	0.19	0.20	0.23	0.24
T ₁₂ 100% Rec. dose WSF	0.15	0.16	0.20	0.21	0.23	0.24
F test	NS	NS	NS	NS	NS	NS
C.D. at 5%	-	-	-	-	-	-

Rec. Dose=150:75:50kg N:P₂O₅:K₂O/ha
DAP = Days after planting

* = Significant
NS = Non-significant

NF = Normal fertilizer
WSF = Water soluble fertilizer

Table-4.5 : Total dry matter accumulation in capsicum as influenced by methods of irrigation, levels and sources of fertilizer during 1994 and 1996

Treatments	Total dry matter accumulation (g/plant)							
	30 DAP		60 DAP		90 DAP		At Final harvest	
	1994	1996	1994	1996	1994	1996	1994	1996
Main treatments								
Irrigation methods								
I ₁ Furrow	1.50	1.68	7.43	8.02	14.09	13.24	14.85	15.5
I ₂ Drip	1.64	1.79	8.77	9.39	16.33	15.71	17.96	18.3
I ₃ Fertigation	1.80	1.86	9.46	9.96	17.74	17.81	19.92	19.3
F test	NS	*	*	*	*	*	*	*
C.D at 5%	-	0.10	1.08	1.17	1.42	2.38	2.50	2.61
Fertilizer levels								
L ₁ 80% Rec. dose	1.60	1.69	8.27	8.82	15.29	15.07	16.68	17.2
L ₂ 100% Rec. dose	1.70	1.86	8.85	9.43	16.82	16.10	18.47	18.2
F test	NS	*	NS	NS	NS	NS	NS	*
C.D at 5%	-	0.12	-	-	-	-	-	1.01
Fertilizer sources								
S ₁ NF	1.65	1.77	8.50	9.16	15.98	15.61	17.44	17.5
S ₂ WSF	1.64	1.79	8.62	9.09	16.13	15.56	17.71	17.7
F test	NS	NS	NS	NS	NS	NS	NS	NS
C.D at 5%	-	-	-	-	-	-	-	-
Combined treatments								
Furrow irrigation								
T ₁ 80% Rec. dose NF	1.48	1.58	7.47	7.87	13.27	12.84	13.32	14.5
T ₂ 80% Rec. dose WSF	1.46	1.62	7.25	7.55	13.33	12.33	13.86	15.4
T ₃ 100% Rec. dose NF	1.57	1.81	7.53	8.33	14.93	13.71	16.51	15.9
T ₄ 100% Rec. dose WSF	1.51	1.72	7.46	8.35	14.84	14.08	15.71	16.3
Drip irrigation								
T ₅ 80% Rec. dose NF	1.61	1.78	8.63	8.87	15.56	15.28	16.83	17.5
T ₆ 80% Rec. dose WSF	1.58	1.72	8.66	8.99	15.43	15.02	17.05	17.7
T ₇ 100% Rec. dose NF	1.70	1.77	9.04	10.03	17.27	16.49	18.77	19.2
T ₈ 100% Rec. dose WSF	1.66	1.89	8.75	9.62	17.06	16.05	19.19	18.8
Fertigation								
T ₉ 80% Rec. dose NF	1.69	1.73	8.38	9.78	16.62	17.38	19.25	18.8
T ₁₀ 80% Rec. dose WSF	1.76	1.72	9.15	9.87	17.50	17.60	19.79	19.2
T ₁₁ 100% Rec. dose NF	1.85	1.93	9.90	10.05	18.22	17.95	19.99	19.4
T ₁₂ 100% Rec. dose WSF	1.89	2.06	10.43	10.16	18.62	18.31	20.64	19.7
F test	NS	NS	NS	NS	NS	NS	NS	NS
C.D. at 5%	-	-	-	-	-	-	-	-

Rec. Dose=150:75:50kg N:P₂O₅:K₂O/ha
DAP = Days after planting

* = Significant
NS = Non-significant

NF = Normal fertilizer
WSF = Water soluble fertilizer

ranged from 1.64 to 18.34 g per plant. Least dry weight was observed under furrow method ranging from 1.50 to 15.59 g per plant (Table-4.5) (Fig. 4.2).

The effect of levels of fertilizer was significant only at harvest in 1996. During other stages, fertilizer at 100% dose registered 1.70 to 18.47 g dry weight compared to 1.60-17.24 g with 80% dose in the two years.

Fertilizer sources either as WSF or NF did not bring any significant differences in total dry matter per plant at 30, 60, 90 DAP and at harvest. With WSF dry weight at these stages ranged from 1.64 to 17.91 g per plant while the corresponding values for NF varied between 1.65 and 17.59 g per plant.

Interaction effects between irrigation methods, levels and sources of fertilizer were not significant at all growth stages.

4.1.6 Dry matter distribution

Data on dry matter distribution into leaf, stem and fruit recorded at 30, 60, 90 DAP and at harvest are presented in Table-4.6.

Dry matter distribution in capsicum at 30 days after planting

The leaf dry matter at 30 DAP was not influenced significantly due to different treatments imposed. However, the trend indicated that fertigated plants had higher leaf dry matter of 0.57 g in 1994 and 0.63 g in 1996 as compared to drip (0.51 and 0.61 g respectively) or furrow method (0.50 and 0.54 g plant⁻¹). Similarly stem dry matter in fertigation was also superior to drip or furrow although statistically non-significant during both 1994 and 1996.

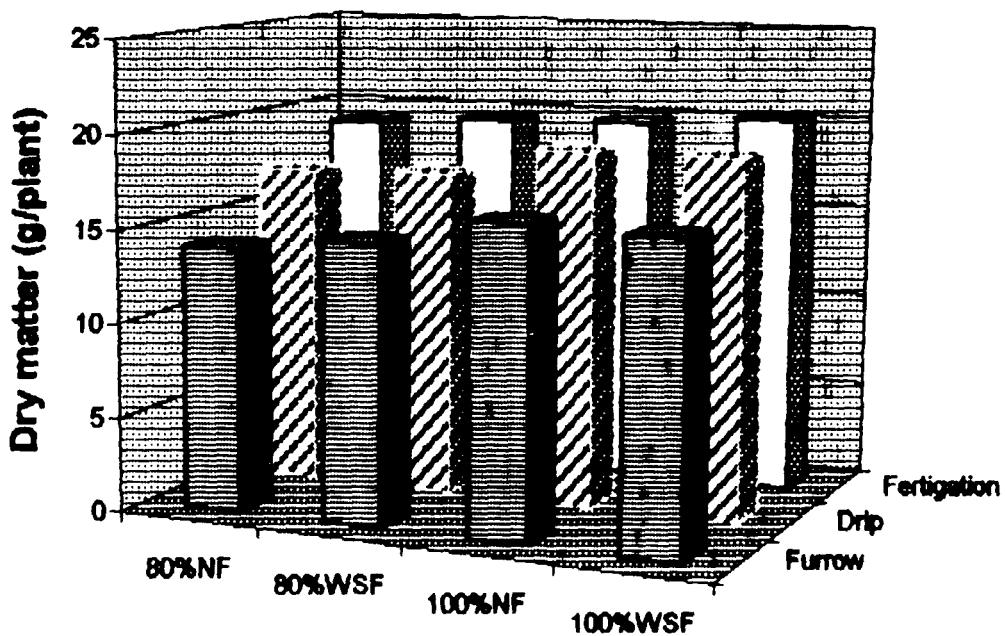

Fig 4.2 : Total drymatter (g/plant) in capsicum at final harvest as influenced by fertigation, drip and furrow with levels and sources of fertilizer(mean of two years)

Table-4.6 : Dry matter distribution in capsicum as influenced by methods of irrigation, levels and sources of fertilizer during 1994 and 1996

Treatments	Dry matter distribution (g/plant)							
	30 DAP				60 DAP			
	Leaf		Stem		Leaf		Stem	
	1994	1996	1994	1996	1994	1996	1994	1996
Main treatments								
Irrigation methods								
I ₁ Furrow	0.50	0.54	1.01	1.14	2.15	2.52	2.35	2.44
I ₂ Drip	0.51	0.61	1.13	1.18	2.66	2.87	2.73	2.79
I ₃ Fertigation	0.57	0.63	1.23	1.23	2.75	3.13	2.85	3.05
F test	NS	NS	NS	NS	*	*	NS	*
C.D at 5%	-	-	-	-	0.36	0.37	-	0.37
Fertilizer levels								
L ₁ 80% Rec. dose	0.50	0.54	1.10	1.15	2.42	2.74	2.55	2.68
L ₂ 100% Rec. dose	0.55	0.64	1.15	1.22	2.62	2.94	2.73	2.84
F test	NS	NS	NS	NS	NS	NS	NS	NS
C.D at 5%	-	-	-	-	-	-	-	-
Fertilizer sources								
S ₁ NF	0.53	0.59	1.13	1.18	2.45	2.84	2.60	2.76
S ₂ WSF	0.53	0.60	1.12	1.19	2.59	2.84	2.70	2.76
F test	NS	NS	NS	NS	NS	NS	NS	NS
C.D at 5%	-	-	-	-	-	-	-	-
Combined treatments								
Furrow irrigation								
T ₁ 80% Rec. dose NF	0.50	0.51	0.98	1.07	2.09	2.40	2.35	2.36
T ₂ 80% Rec. dose WSF	0.48	0.48	0.98	1.14	2.13	2.32	2.24	2.27
T ₃ 100% Rec. dose NF	0.53	0.60	1.07	1.21	2.14	2.65	2.45	2.57
T ₄ 100% Rec. dose WSF	0.49	0.57	1.02	1.15	2.24	2.72	2.37	2.55
Drip irrigation								
T ₅ 80% Rec. dose NF	0.51	0.58	1.10	1.20	2.60	2.77	2.67	2.72
T ₆ 80% Rec. dose WSF	0.48	0.55	1.10	1.17	2.73	2.80	2.76	2.76
T ₇ 100% Rec. dose NF	0.51	0.62	1.19	1.15	2.62	3.04	2.72	2.87
T ₈ 100% Rec. dose WSF	0.52	0.68	1.14	1.21	2.67	2.88	2.79	2.83
Fertigation								
T ₉ 80% Rec. dose NF	0.49	0.55	1.20	1.18	2.31	3.04	2.52	2.97
T ₁₀ 80% Rec. dose WSF	0.55	0.57	1.21	1.15	2.68	3.10	2.80	3.03
T ₁₁ 100% Rec. dose NF	0.61	0.66	1.24	1.27	2.93	3.17	2.89	3.10
T ₁₂ 100% Rec. dose WSF	0.63	0.73	1.26	1.33	3.09	3.20	3.22	3.12
F test	NS	NS	NS	NS	NS	NS	NS	NS
C.D. at 5%	-	-	-	-	-	-	-	-

Rec. Dose=150:75:50kg N:P₂O₅:K₂O/ha
DAP = Days after planting

* = Significant
NS = Non-significant

NF = Normal fertilizer
WSF = Water soluble fertilizer

Contd.

Table-4.6 : (Contd.) Dry matter distribution in capsicum as influenced by methods of irrigation, levels and sources of fertilizer during 1994 and 1996

Treatments	Dry matter distribution (g/plant)							
	60 DAP		Stem		90 DAP		Fruit	
	Fruit		1994	1996	Leaf		1994	1996
Main treatments								
Irrigation methods								
I ₁ Furrow	2.93	3.06	5.97	5.89	3.48	3.22	4.56	4.13
I ₂ Drip	3.39	3.72	6.78	6.45	3.80	3.77	5.75	5.49
I ₃ Fertigation	3.86	3.81	7.46	6.63	4.06	4.09	6.24	6.56
F test	*	*	*	NS	NS	*	*	*
C.D at 5%	0.49	0.58	1.03	-	-	0.70	0.73	1.10
Fertilizer levels								
L ₁ 80% Rec. dose	3.29	3.40	6.28	6.12	3.66	3.57	5.29	5.23
L ₂ 100% Rec. dose	3.50	3.66	7.18	6.53	3.90	3.81	5.74	5.55
F test	NS	NS	NS	NS	NS	NS	NS	NS
C.D at 5%	-	-	-	-	-	-	-	-
Fertilizer sources								
S ₁ Normal Fertilizer(NF)	3.45	3.55	6.69	6.45	3.76	3.68	5.53	5.40
S ₂ Water Soluble Fertilizer (WSF)	3.34	3.51	6.76	6.20	3.80	3.70	5.51	5.38
F test	NS	NS	NS	NS	NS	NS	NS	NS
C.D at 5%	-	-	-	-	-	-	-	-
Combined treatments								
Furrow irrigation								
T ₁ 80% Rec. dose NF	3.03	3.11	5.50	5.67	3.48	3.10	4.29	4.07
T ₂ 80% Rec. dose WSF	2.91	2.96	5.45	5.38	3.39	3.04	4.16	3.71
T ₃ 100% Rec. dose NF	2.94	3.11	6.50	6.19	3.52	3.26	4.91	4.26
T ₄ 100% Rec. dose WSF	2.85	3.08	6.43	6.12	3.53	3.48	4.88	4.48
Drip irrigation								
T ₅ 80% Rec. dose NF	3.36	3.38	6.43	6.24	3.73	3.65	5.40	5.39
T ₆ 80% Rec. dose WSF	3.17	3.43	6.26	6.12	3.65	3.59	5.52	5.31
T ₇ 100% Rec. dose NF	3.73	4.17	7.25	6.81	3.92	3.99	6.10	5.69
T ₈ 100% Rec. dose WSF	3.29	3.91	7.18	6.63	3.90	3.85	5.98	5.57
Fertigation								
T ₉ 80% Rec. dose NF	3.58	3.77	6.73	6.98	3.69	3.98	6.20	6.42
T ₁₀ 80% Rec. dose WSF	3.67	3.75	7.30	6.12	4.02	4.07	6.18	6.50
T ₁₁ 100% Rec. dose NF	4.05	3.78	7.76	6.81	4.20	4.12	6.26	6.59
T ₁₂ 100% Rec. dose WSF	4.14	3.94	7.97	6.63	4.33	4.19	6.32	6.73
F test	NS	NS	NS	NS	NS	NS	NS	NS
C.D. at 5%	-	-	-	-	-	-	-	-

Rec. Dose=150:75:50kg N:P₂O₅:K₂O/ha
DAP = Days after planting

* = Significant
NS = Non-significant

NF = Normal fertilizer
WSF = Water soluble fertilizer

Contd.

Table-4.6 : (Contd.) Dry matter distribution in capsicum as influenced by methods of irrigation, levels and sources of fertilizer during 1994 and 1996

Treatments	Dry matter distribution (g/plant)					
	At Final harvest					
	Stem		Leaf		Fruit	
	1994	1996	1994	1996	1994	1996
Main treatments						
Irrigation methods						
I ₁ Furrow	6.33	6.38	3.13	3.30	5.47	5.89
I ₂ Drip	7.36	7.75	3.50	3.65	6.69	6.86
I ₃ Fertigation	8.46	8.19	3.88	3.66	7.74	7.45
F test	*	*	*	NS	*	*
C.D at 5%	0.78	1.32	0.57	-	1.21	1.02
Fertilizer levels						
L ₁ 80% Rec. dose	7.01	7.28	3.36	3.36	6.26	6.58
L ₂ 100% Rec. dose	7.76	7.60	3.65	3.71	7.01	6.89
F test	NS	NS	NS	*	*	NS
C.D at 5%	-	-	-	0.29	0.59	-
Fertilizer sources						
S ₁ Normal Fertilizer(NF)	7.36	7.31	3.46	3.51	6.57	6.70
S ₂ Water Soluble Fertilizer (WSF)	7.41	7.57	3.55	3.56	6.69	6.76
F test	NS	NS	NS	NS	NS	NS
C.D at 5%	-	-	-	-	-	-
Combined treatments						
Furrow irrigation						
T ₁ 80% Rec. dose NF	6.02	5.95	2.85	3.10	4.45	5.54
T ₂ 80% Rec. dose WSF	6.14	6.58	3.16	2.92	4.89	5.91
T ₃ 100% Rec. dose NF	6.67	6.38	3.28	3.48	6.56	6.09
T ₄ 100% Rec. dose WSF	6.50	6.61	3.23	3.70	5.98	6.02
Drip irrigation						
T ₅ 80% Rec. dose NF	7.24	7.60	3.29	3.40	6.30	6.55
T ₆ 80% Rec. dose WSF	6.08	7.47	3.46	3.51	6.51	6.74
T ₇ 100% Rec. dose NF	7.76	7.76	3.75	3.89	6.93	7.22
T ₈ 100% Rec. dose WSF	8.35	8.16	3.49	3.80	7.02	6.93
Fertigation						
T ₉ 80% Rec. dose NF	7.98	7.86	3.65	3.55	7.62	7.36
T ₁₀ 80% Rec. dose WSF	8.59	8.19	3.74	3.71	7.79	7.38
T ₁₁ 100% Rec. dose NF	8.49	8.32	3.92	3.65	7.58	7.46
T ₁₂ 100% Rec. dose WSF	8.78	8.40	4.22	3.74	7.97	7.60
F test	NS	NS	NS	NS	NS	NS
C.D. at 5%	-	-	-	-	-	-

Rec. Dose=150:75:50kg N:P₂O₅:K₂O/ha
DAP = Days after planting

* = Significant
NS = Non-significant

NF = Normal fertilizer
WSF = Water soluble fertilizer

Leaf and stem dry matter of capsicum plants was insignificantly higher with increased fertilizer dose (100%) than with reduced dose (80%). Likewise, variation due to either sources of fertilizer or interaction effects was also not significant.

Dry matter distribution in capsicum at 60 days after planting

Leaf dry weight was significantly higher (2.75 g and 3.13 g plant⁻¹) under the influence of fertigation during both 1994 and 1996. However, this was on par with drip method (2.66 g and 2.87 g plant⁻¹ respectively). Furrow irrigation alone resulted in the lowest leaf dry matter (2.15 g and 2.52 g plant⁻¹).

Significant differences were noticed in 1996 in terms of stem dry weight (3.05 g) with fertigated plants and it was on par with drip irrigated capsicum (2.79 g) and both of these were found superior to stem dry matter obtained with furrow irrigation treatment (2.44 g).

Application of fertilizers via drip (fertigation) produced significantly higher fruit dry matter in both the years 1994 and 1996 (3.86 g and 3.81 g plant⁻¹) than compared to furrow irrigation (2.93 and 3.06 g plant⁻¹ respectively). However, fruit dry weight observed under drip method was also superior to furrow only in 1996 (3.72 g plant⁻¹).

Dry matter distribution into leaf, stem and fruit was not influenced by levels of fertilizer. However, increased fertilizer dose (100%) increased these components than observed with reduced dose (80%). Higher fruit dry matter of 3.50 g and 3.66 g plant⁻¹ during the years 1994 and 1996 respectively was registered by 100% dose as compared to corresponding values of 3.29 g and 3.40 g plant⁻¹ produced by 80% dose.

Variations due to sources of fertilizers as well as interaction effects were not statistically significant with respect to dry matter distribution at 60 DAP.

Dry matter distribution in capsicum at 90 days after planting (Table-4.6)

Dry matter distribution was significantly influenced by direct effect of irrigation methods barring stem dry matter in 1996 and leaf in 1994. The highest stem dry matter of 7.46 g, stem dry matter of 4.06 g and fruit dry matter of 6.24 g and 6.56 g plant⁻¹ for the years 1994 and 1996 respectively were recorded with fertigation which were significantly superior to furrow method which had the corresponding values of 5.97, 3.22, 4.56 and 4.13 g plant⁻¹. However, drip method was on par with the fertigation method in terms of stem, leaf and fruit dry matter during both the years 1994 and 1996.

The dry matter distribution did not differ significantly between the full dose (100%) and reduced dose (80%) except for leaf in 1996 and fruit in 1994 where 100% level was superior to 80% level. The fertilizer sources of WSF and NF produced identical dry matter of stem, leaf and fruit in both the years. Similarly, interaction effects between I x L, L x S, I x S or I x L x S were found non-significant (Table-4.6).

Dry matter distribution in capsicum at final harvest (Table-4.6)

The data presented in Table-4.6 indicated that fertigation influenced the dry matter distribution in different plant parts at final harvest except leaf dry matter in 1996. Significantly, higher values of dry matter in stem (8.46 g and 8.19 g in 1994 and 1996), leaf (3.88 g in 1994) and fruit (7.74 and 7.45 g in 1994 and 1996 respectively) were obtained with fertigation than those with furrow method (6.33 g, 6.38 g, 3.13 g, 5.47 g and 5.89 g correspondingly) but these fertigation values were on par with drip method (7.36 g, 7.75 g, 3.50 g, 6.69 g and 6.38 g correspondingly).

Fertilizer levels significantly affected only leaf and fruit dry weight in 1996 and 1994 respectively. Recommended fertilizer dose of 100% registered significantly higher leaf dry matter

of 3.71 g compared to 3.36 g plant⁻¹ with 80%. Similarly the fruit dry weight was significantly higher (7.01 g) with full dose than with reduced dose (6.26 g plant⁻¹).

The NF or WSF sources did not evince significant response in terms of dry matter distribution at final harvest. Interactions were also absent with dry matter values in stem (7.86-8.78 g), leaf (3.55-4.72 g) and fruit (7.36-7.97 g) in fertigation comparable with drip system (7.24-8.35 g, 3.29-3.89 g and 6.30-7.02 g correspondingly) and (5.95-6.67 g, 2.85-3.70 g and 4.45-6.56 g respectively) with furrow method.

4.1.7 Number of branches in capsicum

Pertinent data on number of branches per plant recorded at final harvest are presented in Table-4.7. While the number of primary branches was not influenced, the secondary and total branches of capsicum were significantly influenced by method of irrigation. Treatment with fertigation had significantly higher secondary (4.87 and 4.89) and total number of branches (70.5 and 7.10) during 1994 and 1996 than furrow method (4.39, 4.47, 6.27 and 6.40 respectively) but they were on par with drip method (4.76, 4.78, 6.80 and 6.93 respectively).

Neither levels of fertilizers nor sources of fertilizer affected the number of branches significantly. Interactions among treatments were also absent.

4.2 Yield and its components in capsicum

4.2.1 Total green fruit yield in capsicum

The data on green fruit yield of capsicum expressed in kg per ha as influenced by methods of irrigation, levels and sources of fertilizers are presented in Table-4.8.

Fertigation produced significantly superior green fruit yield of 9392 kg ha⁻¹ in 1994 and 9253 kg in 1996 compared to furrow irrigation which gave 7638 kg and 7696 kg ha⁻¹

Table-4.7 : Number of branches in capsicum as influenced by methods of irrigation, levels and sources of fertilizer during 1994 and 1996

Treatments	Number of branches/plant					Total
	Primary		Secondary			
	1994	1996	1994	1996	1994	1996
Main treatments						
Irrigation methods						
I ₁ Furrow	1.86	1.93	4.39	4.47	6.25	6.40
I ₂ Drip	2.04	2.15	4.76	4.78	6.80	6.93
I ₃ Fertigation	2.21	2.21	4.87	4.89	7.08	7.10
F test	NS	NS	*	*	*	*
C.D at 5%	-	-	0.35	0.30	0.43	0.42
Fertilizer levels						
L ₁ 80% Rec. dose	1.97	2.05	4.63	4.66	6.59	6.71
L ₂ 100% Rec. dose	2.10	2.14	4.70	4.77	6.82	6.91
F test	NS	NS	NS	NS	NS	NS
C.D at 5%	-	-	-	-	-	-
Fertilizer sources						
S ₁ NF	2.03	2.10	4.67	4.72	6.71	6.82
S ₂ WSF	2.04	2.09	4.66	4.71	6.70	6.80
F test	NS	NS	NS	NS	NS	NS
C.D at 5%	-	-	-	-	-	-
Combined treatments						
Furrow irrigation						
T ₁ 80% Rec. dose NF	1.87	1.91	4.23	4.36	6.10	6.27
T ₂ 80% Rec. dose WSF	1.75	1.86	4.31	4.45	6.06	6.31
T ₃ 100% Rec. dose NF	1.91	1.94	4.50	4.56	6.41	6.50
T ₄ 100% Rec. dose WSF	1.92	2.01	4.53	4.50	6.52	6.51
Drip irrigation						
T ₅ 80% Rec. dose NF	1.98	2.13	4.78	4.71	6.76	6.84
T ₆ 80% Rec. dose WSF	1.90	2.06	4.67	4.76	6.57	6.82
T ₇ 100% Rec. dose NF	2.12	2.24	4.78	4.86	6.90	7.10
T ₈ 100% Rec. dose WSF	2.17	2.18	4.80	4.79	6.97	6.97
Fertigation						
T ₉ 80% Rec. dose NF	2.40	2.16	4.81	4.87	6.95	7.03
T ₁₀ 80% Rec. dose WSF	2.20	2.19	5.00	4.81	7.13	7.00
T ₁₁ 100% Rec. dose NF	2.19	2.24	4.95	4.96	7.13	7.20
T ₁₂ 100% Rec. dose WSF	2.31	2.26	4.67	4.93	6.98	7.19
F test	NS	NS	NS	NS	NS	NS
C.D. at 5%	-	-	-	-	-	-

Rec. Dose=150:75:50kg N:P₂O₅:K₂O/ha
DAP = Days after planting

* = Significant
NS = Non-significant

NF = Normal fertilizer
WSF = Water soluble fertilizer

respectively. Yield figures of 8631 kg and 8754 kg ha⁻¹ under drip method were on par with corresponding yields obtained with either in fertigation or furrow irrigation (Fig. 4.3).

Fertilizer level at 100% recommended dose had identical green fruit yields of 8427 kg and 8442 kg in 1994 and 1996 respectively compared to the ones at 80% dose of 8685 kg and 8693 kg correspondingly. Also, there were no significant differences observed between NF and WSF sources in terms of green fruit yield. Combined effect of irrigation methods with fertilizer levels or sources did not result in significant differences in fruit yield.

4.2.2 Green fruit yield of capsicum at different pickings (kg ha⁻¹)

The data on green fruit yield at different pickings as influenced by different treatments under study are presented in Table-4.9.

The green fruit yield increased gradually reaching its peak at third picking and then declined in fourth picking. The data revealed that fertigation and drip methods significantly increased the green fruit yield at all the pickings except in II picking in 1994 and final picking in 1996. Yields under fertigation varied from 2053 kg to 3164 kg ha⁻¹ while the drip method gave 1806 to 2957 kg ha⁻¹. Significantly lower yields were obtained with furrow treatment ranging from 1638 to 2619 kg ha⁻¹.

Levels of fertilizer did not differ statistically with green fruit yields of 1834 to 2947 kg ha⁻¹ with 100% dose and 1829 to 2899 kg ha⁻¹ with 80% level. Also, the differences in fertilizer sources were on par with each other in terms of green fruit yield at different pickings in both the years. The variation in fruit yield due to interaction effects of different factors were not statistically significant.

Table-4.8 : Total green fruits yield in capsicum as influenced by methods of irrigation, levels and sources of fertilizer during 1994 and 1996

Treatments	Green fruit yield (kg/ha)						
	1994			1996			
	80% Rec. dose (L ₁)	100% Rec. dose (L ₂)	Mean	80% Rec. dose (L ₁)	100% Rec. dose (L ₂)	Mean	
Main treatments							
<u>Irrigation methods</u>							
I ₁ Furrow	7488	7788	7638	7579	7812	7696	
I ₂ Drip	8466	8795	8631	8636	8872	8754	
I ₃ Fertigation	9313	9470	9392	9111	9394	9253	
Mean	8423	8685		8442	8693		
<u>Fertilizer sources</u>							
S ₁ NF	8423	8704	8564	8488	8656	8572	
S ₂ WSF	8422	8665	8544	8396	8729	8563	
Mean	8423	8685		8442	8693		
<u>Irrigation methods</u>							
	<u>NF(S₁)</u>	<u>WSF(S₂)</u>		<u>NF(S₁)</u>	<u>WSF(S₂)</u>		
I ₁ Furrow	7684	7591	7638	7750	7641	7696	
I ₂ Drip	8664	8598	8631	8746	8762	8754	
I ₃ Fertigation	9342	9441	9392	9220	9585	9253	
Mean	8564	8544		8572	8563		
	I ₁	I ₂	I ₃	I ₁	I ₂	I ₃	
L ₁ -100%R.D.	S ₁ -NF	7523	8501	9245	7641	8667	9157
	S ₂ -WSF	7453	8432	9382	7518	8605	9066
L ₂ - 80%R.D.	S ₁ -NF	7846	8827	9440	7860	8825	9284
	S ₂ -WSF	7730	8764	9501	7765	8919	9505
	<u>F-test</u>	<u>C.D at 5%</u>		<u>F-test</u>	<u>C.D at 5%</u>		
I	*	1231		*	1160		
L	NS	-		NS	-		
S	NS	-		NS	-		
I x L	NS	-		NS	-		
L x S	NS	-		NS	-		
I x S	NS	-		NS	-		
I x L x S	NS	-		NS	-		

Rec. Dose=150:75:50kg N:P₂O₅:K₂O/ha
DAP = Days after planting

* = Significant
NS = Non-significant

NF = Normal fertilizer
WSF = Water soluble fertilizer

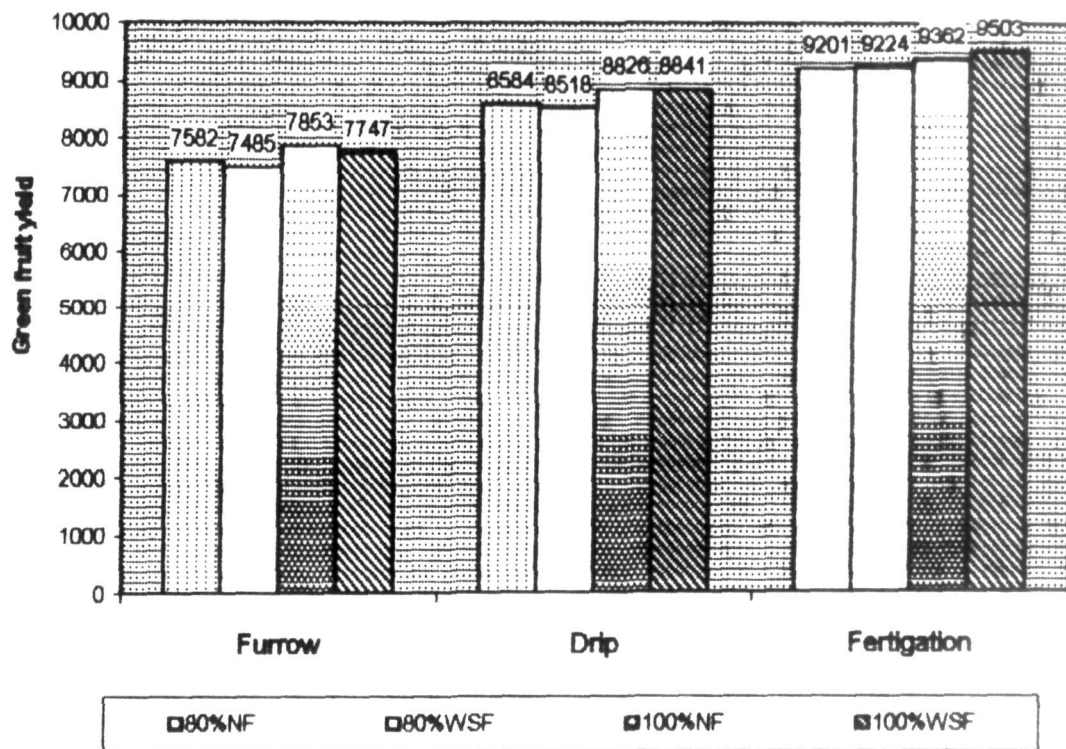

Fig 4.3 Green fruit yield (kg/ha) in capsicum as influenced by fertigation, drip and furrow with sources and levels of fertilizer (mean of two years)

Table-4.9 : Green fruit yield in capsicum at different pickings as influenced by methods of irrigation levels and sources of fertilizer during 1994 and 1996

Treatments	Green fruit yield (kg/ha)							
	I Picking		II Picking		III Picking		IV Picking	
	1994	1996	1994	1996	1994	1996	1994	1996
Main treatments								
Irrigation methods								
I ₁ Furrow	1638	1642	2500	2414	2557	2619	935	1024
I ₂ Drip	1806	1924	2802	2779	2957	2915	1076	1135
I ₃ Fertigation	2053	2057	2965	2917	3164	3137	1201	1139
F test	*	*	NS	*	*	*	*	NS
C.D at 5%	261	234	-	281	269	329	130	-
Fertilizer levels								
L ₁ 80% Rec. dose	1831	1853	2695	2655	2853	2835	1042	1097
L ₂ 100% Rec. dose	1834	1894	2816	2751	2932	2947	1099	1102
F test	NS	NS	NS	NS	NS	NS	NS	NS
C.D at 5%	-	-	-	-	-	-	-	-
Fertilizer sources								
S ₁ NF	1835	1873	2764	2706	2895	2892	1061	1100
S ₂ WSF	1829	1875	2745	2701	2890	2889	1080	1098
F test	NS	NS	NS	NS	NS	NS	NS	NS
C.D at 5%	-	-	-	-	-	-	-	-
Combined treatments								
Furrow irrigation								
T ₁ 80% Rec. dose NF	1663	1657	2440	2387	2528	2578	892	1019
T ₂ 80% Rec. dose WSF	1641	1633	2410	2355	2497	2552	905	978
T ₃ 100% Rec. dose NF	1632	16483	2622	2478	2597	2680	962	1054
T ₄ 100% Rec. dose WSF	1616	1627	2528	2436	2606	2666	980	1044
Drip irrigation								
T ₅ 80% Rec. dose NF	1841	1918	2727	2731	2938	2888	1005	1130
T ₆ 80% Rec. dose WSF	1795	1936	2692	2700	2897	2843	1058	1126
T ₇ 100% Rec. dose NF	1803	1947	2890	2782	3017	2955	1127	1141
T ₈ 100% Rec. dose WSF	1785	1895	2899	2905	2976	2974	1114	1145
Fertigation								
T ₉ 80% Rec. dose NF	2005	1979	2938	2926	3107	3068	1165	1174
T ₁₀ 80% Rec. dose WSF	2041	1996	2964	2834	3152	3081	1225	1155
T ₁₁ 100% Rec. dose NF	2067	2087	2972	2933	3185	3181	1216	1084
T ₁₂ 100% Rec. dose WSF	2099	2166	2988	2975	3214	3219	1200	1145
F test	NS	NS	NS	NS	NS	NS	NS	NS
C.D. at 5%	-	-	-	-	-	-	-	-

Rec. Dose=150:75:50kg N:P₂O₅:K₂O/ha
DAP = Days after planting

* = Significant
NS = Non-significant

NF = Normal fertilizer
WSF = Water soluble fertilizer

4.2.3 Total Green fruit yield in capsicum (g plant⁻¹)

The data on total green fruit yield g per plant is influenced by methods of irrigation, levels and sources of fertilizer are presented in Table-4.10.

Total green fruit yield was significantly influenced by irrigation methods. In 1994, fertigation alone produced the highest green fruit yield per plant (438 g) as compared to drip (372 g) and furrow (314 g). Whereas in 1996 fertigation and drip were on par with each other in terms of green fruit yield (430 g and 375 g respectively) per plant but the former was significantly superior to furrow method which yielded 317 g plant⁻¹.

Both the fertilizer levels were statistically identical with respect to green fruit yield per plant which was 363 and 387 g plant⁻¹ with 100% in 1994 and 1996 and 363 g plant⁻¹ in both the years respectively. Similarly both the fertilizer sources registered on par green fruit yield plant⁻¹. There were no significant differences observed due to interaction effect among the treatment combinations.

4.2.4 Number of green fruit per plant in capsicum

Data on number of green fruits per plant as influenced by methods of irrigation, levels and sources of fertilizer are presented in Table-4.11 and Fig. 4.4.

The total number of green fruits varied significantly due to irrigation methods. Highest number of green fruits per plant was harvested with fertigation in both the years. Fertigation alone was significantly superior to drip and furrow (6.91, 6.26 and 5.70 fruits per plant respectively) in 1994, while in 1996, both fertigation and drip were on par between themselves but the former being superior to furrow method (6.75, 6.20 and 5.63 fruits per plant respectively).

Among the four pickings, fertigation method registered significantly higher number of green fruits per plant than other two methods of irrigation only at II picking in 1996 but was on

Table-4.10 : Total green fruit yield in capsicum as influenced by methods of irrigation, levels and sources of fertilizer during 1994 and 1996

Treatments	Green fruit yield (g/pl)					
	1994			1996		
	80% Rec. dose (L ₁)	100% Rec. dose (L ₂)	Mean	80% Rec. dose (L ₁)	100% Rec. dose (L ₂)	Mean
Main treatments						
Irrigation methods						
I ₁ Furrow	307	321	314	307	327	317
I ₂ Drip	357	387	372	365	385	375
I ₃ Fertigation	424	452	438	418	442	430
Mean	363	387		363	385	
Fertilizer sources						
S ₁ NF	361	388	375	361	382	371
S ₂ WSF	364	385	375	366	387	377
Mean	363	387		363	385	
Irrigation methods						
	<u>NF(S₁)</u>	<u>WSF(S₂)</u>		<u>NF(S₁)</u>	<u>WSF(S₂)</u>	
I ₁ Furrow	316	313	314	319	315	317
I ₂ Drip	375	368	372	373	378	375
I ₃ Fertigation	432	444	438	422	438	430
Mean	375	375		371	377	
Interaction of Irrigation methods and Fertilizer sources						
L ₁ -100%R.D.	<u>I₁</u>	<u>I₂</u>	<u>I₃</u>	<u>I₁</u>	<u>I₂</u>	<u>I₃</u>
S ₁ -NF	308	360	416	310	364	408
S ₂ -WSF	309	354	432	304	366	427
L ₂ - 80%R.D.	<u>I₁</u>	<u>I₂</u>	<u>I₃</u>	<u>I₁</u>	<u>I₂</u>	<u>I₃</u>
S ₁ -NF	324	391	448	328	382	435
S ₂ -WSF	319	382	455	325	389	448
Statistical analysis						
	<u>F-test</u>	<u>C.D at 5%</u>		<u>F-test</u>	<u>C.D at 5%</u>	
I	*	59		*	77	
L	NS	-		NS	-	
S	NS	-		NS	-	
I x L	NS	-		NS	-	
L x S	NS	-		NS	-	
I x S	NS	-		NS	-	
I x L x S	NS	-		NS	-	

Rec. Dose=150:75:50kg N:P₂O₅:K₂O/ha
DAP = Days after planting

* = Significant
NS = Non-significant

NF = Normal fertilizer
WSF = Water soluble fertilizer

Table-4.11: Number of green fruits per plant in capsicum at different pickings as influenced by methods of irrigation, levels and sources of irrigation during 1994 and 1996

Treatments	Number of green fruits per plant									
	Total		I Picking		II Picking		III Picking		IV Picking	
	1994	1996	1994	1996	1994	1996	1994	1996	1994	1996
Main treatments										
Irrigation methods										
I ₁ Furrow	5.67	5.63	0.67	0.69	1.55	1.57	2.69	2.51	0.76	0.85
I ₂ Drip	6.26	6.20	0.85	0.86	1.63	1.68	2.82	2.67	0.97	0.99
I ₃ Fertigation	6.91	6.75	0.95	0.98	1.74	1.83	3.05	2.87	1.15	1.06
F test	*	*	NS	*	*	*	*	*	NS	NS
C.D at 5%	0.63	0.60	-	0.15	0.14	0.14	0.23	0.24	-	-
Fertilizer levels										
L ₁ 80% Rec. dose	6.18	6.08	0.79	0.82	1.60	1.68	2.81	2.63	0.94	0.97
L ₂ 100% Rec. dose	6.41	6.31	0.86	0.87	0.69	1.71	2.86	2.74	0.98	0.97
F test	NS	NS	NS	NS	NS	NS	NS	NS	NS	NS
C.D at 5%	-	-	-	-	-	-	-	-	-	-
Fertilizer sources										
S ₁ NF	6.27	6.16	0.81	0.84	1.64	1.69	2.85	2.68	0.94	0.94
S ₂ WSF	6.31	6.23	0.83	0.85	1.64	1.70	2.86	2.69	0.98	1.00
F test	NS	NS	NS	NS	NS	NS	NS	NS	NS	NS
C.D at 5%	-	-	-	-	-	-	-	-	-	-
Combined treatments										
Furrow irrigation										
T ₁ 80% Rec. dose NF	5.66	5.50	0.65	0.68	1.50	1.53	2.65	2.46	0.70	0.80
T ₂ 80% Rec. dose WSF	5.54	5.44	0.62	0.65	1.47	1.59	2.60	2.40	0.79	0.91
T ₃ 100% Rec. dose NF	5.81	5.80	0.73	0.74	1.63	1.61	2.74	2.62	0.77	0.80
T ₄ 100% Rec. dose WSF	5.78	5.77	0.69	0.71	1.59	1.56	2.79	2.58	0.77	0.89
Drip irrigation										
T ₅ 80% Rec. dose NF	6.06	6.06	0.78	0.82	1.62	1.68	2.78	2.63	0.86	0.95
T ₆ 80% Rec. dose WSF	6.22	6.14	0.86	0.84	1.59	1.65	2.76	2.60	0.98	1.05
T ₇ 100% Rec. dose NF	6.40	6.27	0.89	0.91	1.63	1.69	2.84	2.71	1.03	0.96
T ₈ 100% Rec. dose WSF	6.27	6.35	0.86	0.86	1.68	1.70	2.89	2.75	1.00	1.02
Fertigation										
T ₉ 80% Rec. dose NF	6.66	6.61	0.86	0.93	1.68	1.79	2.99	2.81	1.13	1.05
T ₁₀ 80% Rec. dose WSF	6.91	6.74	0.96	0.98	1.72	1.84	3.06	2.87	1.16	1.07
T ₁₁ 100% Rec. dose NF	7.02	6.75	0.98	0.97	1.78	1.83	3.10	2.88	1.14	1.07
T ₁₂ 100% Rec. dose WSF	7.06	6.92	1.02	1.05	1.80	1.86	3.07	2.93	1.17	1.06
WSF	NS	NS	NS	NS	NS	NS	NS	NS	NS	NS
F test	-	-	-	-	-	-	-	-	-	-
C.D. at 5%	-	-	-	-	-	-	-	-	-	-

Rec. Dose=150:75:50kg N:P₂O₅:K₂O/ha
DAP = Days after planting

* = Significant
NS = Non-significant

NF = Normal fertilizer
WSF = Water soluble fertilizer

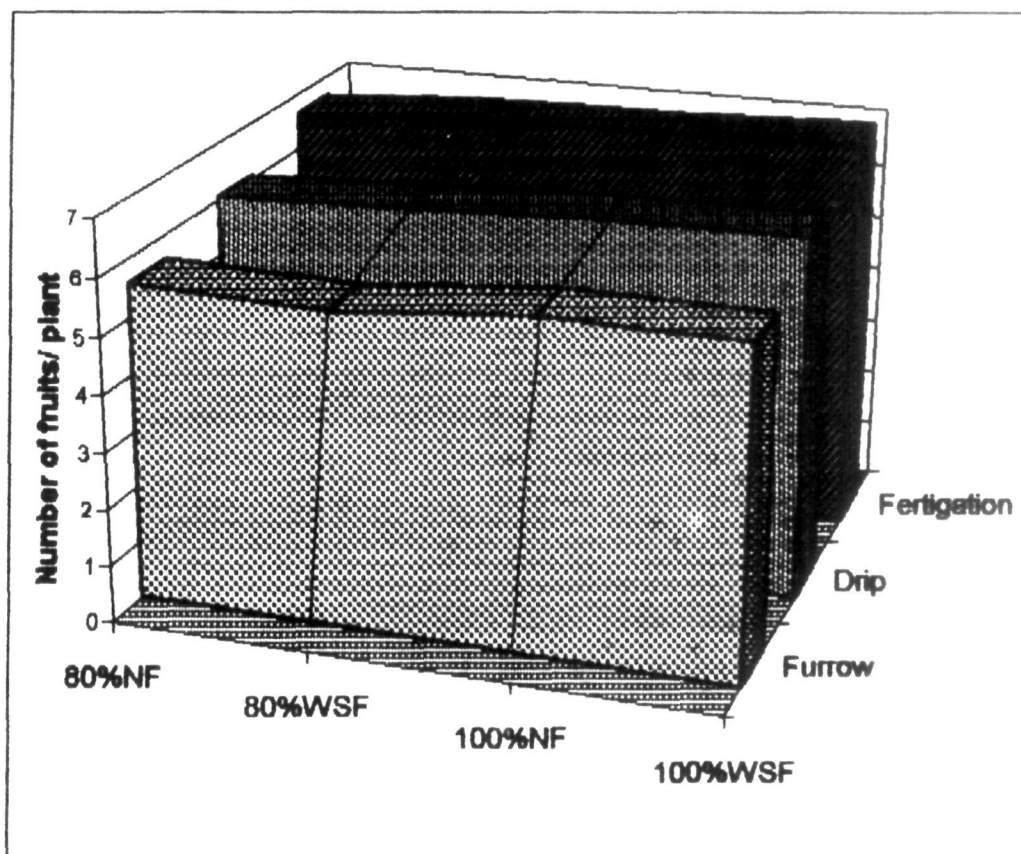

Fig. 4.4 : Number of green fruits per plant in capsicum as influenced by fertigation, drip and furrow with levels and sources of fertilizer (mean of two years)

par with drip at I picking in 1996, II picking in 1994 and III picking in both the years. Furrow method produced the lowest number of green fruits per plant in all the pickings.

Both the levels of 80% to 100% recommended fertilizers had identical number of green fruits per plant. With 100% level total number of green fruits 6.41 and 6.31 in 1994 and 1996 respectively and number of green fruits harvested at different pickings 0.86-2.86 were comparable those of the reduced dose (6.18 and 6.08, 0.79-2.81 correspondingly).

Fertilizer sources of WSF (6.31 and 6.23) and NF (6.27 and 6.16 fruits plant⁻¹ respectively) were identical in the number of fruits plant⁻¹. Similarly number of green fruits with WSF at all four pickings in both the years (0.83 to 2.86) were on par with NF (0.81 to 2.85 fruits plant⁻¹).

4.2.5 Green fruit length of capsicum

Data on green fruit length at different pickings as influenced by methods of irrigation, levels and sources of fertilizer are presented in Table-4.12. The green fruit length was 5.49 cm with fertigation which was significantly superior compare to 4.94 cm in drip and 4.79 cm in furrow method during 1994 at first picking. Green fruit length recorded in II and III pickings (6.74 to 7.47 cm) in both the years 1994 and 1996 due to fertigation treatment was on par with drip (6.46 to 6.83 cm fruit length) but significantly superior to furrow method (5.74 to 5.70 cm fruit length).

Full dose (100%) of fertilizer produced significantly maximum fruit length (5.25 cm) at I picking in 1996 and at II picking in 1996 (6.33 cm) as compared to reduced dose (80%) (4.90 cm and 5.53 cm fruit length respectively). Sources of fertilizers were identical in response except in II picking during 1996 where NF recorded higher fruit length (6.12 cm) compared to WSF source (5.74 cm fruit length).

Table-4.12: Green fruit length in capsicum at different pickings as influenced by methods of irrigation levels and sources of fertilizer during 1994 and 1996

Treatments	Green fruit length (cm)							
	I Picking		II Picking		III Picking		IV Picking	
	1994	1996	1994	1996	1994	1996	1994	1996
Main treatments								
Irrigation methods								
I ₁ Furrow	4.95	4.79	5.74	5.35	5.96	5.70	3.83	3.97
I ₂ Drip	5.11	4.84	6.46	5.84	6.73	6.83	3.89	4.46
I ₃ Fertigation	5.66	5.49	6.74	6.59	7.14	7.47	4.26	4.74
F test	NS	*	*	*	*	*	NS	NS
C.D at 5%	-	-	0.52	0.89	0.78	1.28	-	-
Fertilizer levels								
L ₁ 80% Rec. dose	5.16	4.90	6.08	5.53	6.72	6.87	3.78	4.11
L ₂ 100% Rec. dose	5.30	5.25	6.54	6.33	6.50	6.53	4.21	4.67
F test	NS	*	NS	*	NS	NS	NS	NS
C.D at 5%	-	0.29	-	0.64	-	-	-	-
Fertilizer sources								
S ₁ NF	5.00	5.05	6.20	6.12	6.59	6.47	4.20	4.42
S ₂ WSF	5.45	5.10	6.42	5.74	6.63	6.87	3.79	4.36
F test	NS	NS	NS	*	NS	NS	NS	NS
C.D at 5%	-	-	-	0.37	-	-	-	-
Combined treatments								
Furrow irrigation								
T ₁ 80% Rec. dose NF	4.64	4.49	5.19	4.67	6.93	5.49	4.00	3.57
T ₂ 80% Rec. dose WSF	4.28	4.60	5.73	5.14	5.88	6.40	3.44	3.96
T ₃ 100% Rec. dose NF	4.88	5.12	5.81	5.56	4.99	5.26	4.33	4.06
T ₄ 100% Rec. dose WSF	5.99	4.95	6.25	6.04	6.05	5.64	3.54	4.30
Drip irrigation								
T ₅ 80% Rec. dose NF	4.95	4.77	6.39	5.78	6.54	5.95	3.68	4.15
T ₆ 80% Rec. dose WSF	5.43	4.75	6.30	5.19	6.11	7.89	3.61	4.46
T ₇ 100% Rec. dose NF	4.89	4.96	6.85	6.77	7.93	7.14	4.30	3.98
T ₈ 100% Rec. dose WSF	5.18	5.30	6.30	5.72	6.35	6.36	3.99	5.26
Fertigation								
T ₉ 80% Rec. dose NF	5.67	5.35	6.17	6.86	6.45	7.45	4.06	4.94
T ₁₀ 80% Rec. dose WSF	6.10	5.44	6.73	5.64	8.42	7.66	3.90	3.58
T ₁₁ 100% Rec. dose NF	4.98	5.62	6.82	7.08	6.72	7.51	4.83	5.82
T ₁₂ 100% Rec. dose WSF	5.89	5.57	7.23	6.78	6.97	7.27	4.26	4.62
F test	NS	NS	NS	NS	*	NS	NS	NS
C.D. at 5%	-	-	-	-	0.95	-	-	-

Rec. Dose=150:75:50kg N:P₂O₅:K₂O/ha
DAP = Days after planting

* = Significant
NS = Non-significant

NF = Normal fertilizer
WSF = Water soluble fertilizer

Interaction between the treatments was significant only at III picking in 1994. Fertigation with WSF at 80% dose produced maximum fruit length (8.42 cm) while the least fruit length (4.99 cm) was recorded with 100% WSF under furrow irrigation.

4.2.6 Green fruit girth in capsicum

The data on green fruit girth in capsicum as influenced by methods of irrigation, levels and sources of fertilizer at different pickings are presented in Table-4.13.

Girth of green fruits varied significantly due to irrigation treatments at I picking in 1994, II and III pickings in both the years 1994 and 1996. Maximum fruit girth (15.5 to 19.8 cm) noticed with fertigation at these stages was significantly superior to furrow method (12.8 to 16.1 cm fruit girth) but was on par with drip method (14.1 to 17.5 cm fruit girth). However, at III picking, fertigated capsicum alone was significantly superior to both drip and furrow irrigation treatments.

Green fruit girth was significantly higher with 100% fertilizer dose (18.12 cm) only at III picking in 1994 than 80% dose (17.15 cm). Generally the full dose maintained higher values of fruit girth consistently over reduced dose at different pickings.

Fertilizer sources did not differ significantly with regard to green fruit girth. Interaction effects on green fruit girth over four pickings were also absent.

4.3 Quality analysis

4.3.1 Ascorbic acid content of capsicum fruits

Data on ascorbic acid content of capsicum fruits at third picking as influenced by methods of irrigation, levels and sources of fertilizers are presented in Table-4.14.

Table-4.13: Green fruit girth in capsicum as influenced by methods of irrigation, levels and sources of fertilizer during 1994 and 1996.

Treatments	Green fruit girth (cm)							
	I Picking		II Picking		III Picking		IV Picking	
	1994	1996	1994	1996	1994	1996	1994	1996
Main treatments								
Irrigation methods								
I ₁ Furrow	12.83	13.52	14.59	14.91	16.12	15.45	11.06	10.7
I ₂ Drip	14.07	14.86	16.89	17.49	17.55	17.14	11.45	11.4
I ₃ Fertigation	15.51	15.10	18.12	18.41	19.23	19.79	11.56	11.2
F test	*	NS	*	*	*	*	NS	NS
C.D at 5%	1.67	-	1.79	1.91	1.56	1.96	-	-
Fertilizer levels								
L ₁ 80% Rec. dose	13.97	14.37	16.24	16.29	17.15	17.08	11.54	11.2
L ₂ 100% Rec. dose	14.31	14.61	16.83	17.35	18.12	17.84	11.63	11.0
F test	NS	NS	NS	NS	*	NS	NS	NS
C.D at 5%	-	-	-	-	0.91	-	-	-
Fertilizer sources								
S ₁ NF	14.14	14.51	16.74	16.75	17.56	17.26	11.61	11.2
S ₂ WSF	14.14	14.47	16.33	16.89	17.71	17.67	11.11	11.0
F test	NS	NS	NS	NS	NS	NS	NS	NS
C.D at 5%	-	-	-	-	-	-	-	-
Combined treatments								
Furrow irrigation								
T ₁ 80% Rec. dose NF	12.98	13.00	15.06	15.29	15.91	14.67	10.48	12.2
T ₂ 80% Rec. dose WSF	12.37	13.36	14.06	14.07	15.59	15.56	12.04	9.36
T ₃ 100% Rec. dose NF	12.83	13.77	13.89	14.89	15.57	16.02	11.24	11.1
T ₄ 100% Rec. dose WSF	13.14	13.94	15.39	15.38	17.02	15.57	10.47	10.2
Drip irrigation								
T ₅ 80% Rec. dose NF	13.67	14.79	16.74	16.04	16.46	16.37	11.35	11.2
T ₆ 80% Rec. dose WSF	13.48	14.88	16.15	17.29	16.93	16.73	10.93	11.6
T ₇ 100% Rec. dose NF	15.03	15.97	17.52	18.03	18.60	17.85	12.16	11.4
T ₈ 100% Rec. dose WSF	14.13	16.81	17.17	17.24	18.21	17.63	11.35	11.3
Fertigation								
T ₉ 80% Rec. dose NF	14.55	14.54	18.07	17.20	18.74	18.83	12.78	11.2
T ₁₀ 80% Rec. dose WSF	16.77	15.67	17.35	17.84	19.27	20.34	11.61	11.5
T ₁₁ 100% Rec. dose NF	15.79	15.10	19.15	19.05	19.68	19.81	11.63	10.0
T ₁₂ 100% Rec. dose WSF	14.95	15.18	17.92	19.54	19.23	20.18	10.29	12.0
F test	NS	NS	NS	NS	NS	NS	NS	NS
C.D. at 5%	-	-	-	-	-	-	-	-

Rec. Dose=150:75:50kg N:P₂O₅:K₂O/ha
DAP = Days after planting

* = Significant
NS = Non-significant

NF = Normal fertilizer
WSF = Water soluble fertilizer

in capsicum

Table-4.14: Ascorbic acid content at third picking as influenced by methods of irrigation levels and sources of fertilizer during 1994 and 1996.

Treatments	Ascorbic acid content (mg/100 g fresh fruit)	
	1994	1996
Main treatments		
Irrigation methods		
I ₁ Furrow	83.68	85.29
L ₂ Drip	94.38	99.08
I ₃ Fertigation	108.61	111.86
F test	*	*
C.D at 5%	11.86	16.87
Fertilizer levels		
L ₁ 80% Rec. dose	95.96	98.25
L ₂ 100% Rec. dose	95.15	99.25
F test	NS	NS
C.D at 5%	-	-
Fertilizer sources		
S ₁ Normal Fertilizer(NF)	91.10	94.08
S ₂ Water Soluble Fertilizer (WSF)	100.00	103.41
F test	*	*
C.D at 5%	7.54	8.31
Combined treatments		
Furrow irrigation		
T ₁ 80% Rec. dose NF	80.15	82.05
T ₂ 80% Rec. dose WSF	89.97	90.54
T ₃ 100% Rec. dose NF	78.37	80.23
T ₄ 100% Rec. dose WSF	86.26	88.36
Drip irrigation		
T ₅ 80% Rec. dose NF	87.27	90.56
T ₆ 80% Rec. dose WSF	98.75	104.90
T ₇ 100% Rec. dose NF	93.36	93.07
T ₈ 100% Rec. dose WSF	98.13	107.81
Fertigation		
T ₉ 80% Rec. dose NF	105.28	108.53
T ₁₀ 80% Rec. dose WSF	114.36	112.92
T ₁₁ 100% Rec. dose NF	102.24	110.06
T ₁₂ 100% Rec. dose WSF	112.56	115.95
F test	NS	NS
C.D. at 5%	-	-

Rec. Dose=150:75:50kg N:P₂O₅:K₂O/ha
DAP = Days after planting

* = Significant
NS = Non-significant

NF = Normal fertilizer
WSF = Water soluble fertilizer

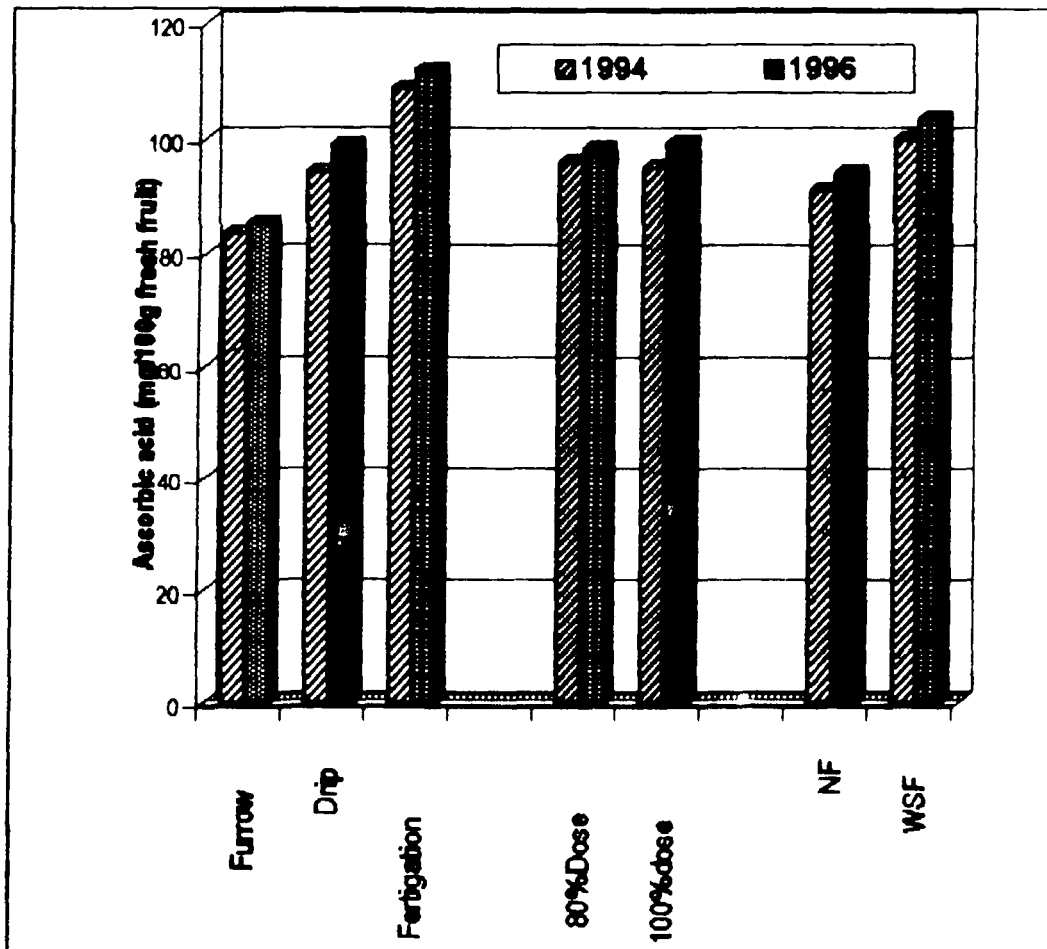

Fig. 4.5 : Ascorbic acid content (mg/100g fresh fruit) in capsicum as influenced by fertigation, drip and furrow with levels and sources of fertilizer

Ascorbic acid content of fresh fruits was influenced significantly by fertigation. It was the highest (108.6 and 111.9 mg per 100 fresh weight in 1994 and 1996 respectively) with fertigation than drip irrigation (94.4 and 99.1 mg respectively). Furrow irrigation resulted in significantly lower values for both the years (83.7 and 85.3 mg respectively) (Fig. 4.5).

The full(100%) and reduced(80%) fertilizer levels did not differ in ascorbic acid content.

Fertilizer applied as WSF source recorded significantly higher vitamin C content of 100 and 103.4 mg per 100 g fresh fruit in 1994 and 1996 respectively compared to NF source (91.1 and 94.1 mg per 100 g fresh fruit correspondingly).

Among the interactions, combination of fertigation improved vitamin C content in fruits (102-115.9 mg per 100 g FF) favourably as compared to drip (87.3-107.8 mg per 100 FF) and furrow (78.4-90.5 mg per 100 mg per 100 g FI) irrigation combinations.

4.4 Growth components of maize

4.4.1 Plant height of maize

The data on plant height of maize as influenced by irrigation methods, levels and sources of fertilizer at 30, 60 and 90 days after sowing (DAS) are presented in Table-4.15.

The plant height was significantly influenced by irrigation methods at all stages except 30 DAS in 1994. Tallest plants were observed under fertigation treatment (72.2 to 196.6 cm) compared to drip irrigation (60.1 to 186.5 cm) at different stages of plant growth. Significantly shorter plants were observed with furrow method (55.6 to 168.3 cm) than fertigated maize.

The plant height with 80% fertilizer level was statistically on par with 100% dose except at 60 DAS in 1996 wherein the corresponding values were 163.5 cm and 171.8 cm. The WSF source registered taller growth (61.3 cm – 182.1 cm) but was on par with NF (60.2 cm – 182.6

Table-4.15 : Plant height in maize as influenced by methods of irrigation, levels and sources of fertilizer during 1994 and 1996

Treatments	Plant height (cm)					
	30 DAS		60 DAS		90 DAS	
	1994	1996	1994	1996	1994	1996
<u>Main treatments</u>						
<u>Irrigation methods</u>						
I ₁ Furrow	55.65	56.43	146.86	152.81	161.23	168.31
I ₂ Drip	60.11	65.36	163.68	169.70	177.28	186.48
I ₃ Fertigation	66.56	72.18	183.21	180.45	196.57	193.88
F test	NS	*	*	*	*	*
C.D at 5%	-	5.93	15.80	19.69	23.07	18.05
<u>Fertilizer levels</u>						
L ₁ 80% Rec. dose	59.39	62.56	162.87	163.48	174.70	177.15
L ₂ 100% Rec. dose	62.17	66.75	166.30	171.82	182.02	188.63
F test	NS	NS	NS	*	NS	NS
C.D at 5%	-	-	-	6.86	-	-
<u>Fertilizer sources</u>						
S ₁ NF	60.24	64.745	162.90	166.62	177.33	182.63
S ₂ WSF	61.31	64.56	166.27	168.69	179.39	183.15
F test	NS	NS	NS	NS	NS	NS
C.D at 5%	-	-	-	-	-	-
<u>Combined treatments</u>						
<u>Furrow irrigation</u>						
T ₁ 80% Rec. dose NF	55.31	55.35	146.60	147.24	160.17	160.44
T ₂ 80% Rec. dose WSF	55.81	52.25	152.33	149.26	153.63	156.35
T ₃ 100% Rec. dose NF	57.63	60.36	139.70	159.46	165.74	182.17
T ₄ 100% Rec. dose WSF	53.86	57.76	148.83	155.28	165.40	174.28
<u>Drip irrigation</u>						
T ₅ 80% Rec. dose NF	59.34	61.34	160.10	167.21	167.40	179.26
T ₆ 80% Rec. dose WSF	56.57	64.75	153.16	166.50	174.51	184.34
T ₇ 100% Rec. dose NF	63.18	66.98	172.16	170.10	186.00	187.23
T ₈ 100% Rec. dose WSF	61.36	68.37	169.29	174.84	181.20	195.09
<u>Fertigation</u>						
T ₉ 80% Rec. dose NF	62.39	71.34	180.69	174.36	189.21	191.97
T ₁₀ 80% Rec. dose WSF	66.91	70.36	184.32	176.19	203.30	190.56
T ₁₁ 100% Rec. dose NF	63.60	73.15	178.14	181.34	195.49	194.72
T ₁₂ 100% Rec. dose WSF	73.37	73.87	189.67	189.91	198.30	198.72
F test	NS	NS	NS	NS	NS	NS
C.D. at 5%	-	-	-	-	-	-

Rec. Dose=150:75:50kg
N:P₂O₅:K₂O/ha
DAS = Days after sowing

* = Significant
NS = Non-significant

NF = Normal fertilizer
WSF = Water soluble fertilizer

cm) at different crop growth stages during both the years 1994 and 1996. Also, no interaction was found significant in influencing the plant height at any stage.

4.4.2 Leaf area in maize

The data on leaf area (cm^2) per plant recorded at 30, 60 and 90 DAS as influenced by different treatments under study are presented in Table-4.16.

There were significant differences in leaf area per plant due to direct effect of irrigation methods at all the stages except at 30 DAS in 1994.

Leaf area per plant was higher in fertigation than drip irrigated maize at all growth stages in both 1994 and 1996. The leaf area was maximum at 60 DAS wherein both fertigation (5791.7 cm^2 and 5735.1 cm^2 in 1994 and 1996 respectively) and drip irrigation (5623.7 cm^2 and 5593.8 cm^2 in 1994 and 1996 respectively) were on par with each other but significantly superior to furrow method which produced 5131.2 cm^2 and 5218.7 cm^2 leaf area in 1994 and 1996 respectively (Fig. 4.6). Similar trend was observed at 90 DAS during both the years.

A decrease in fertilizer level from 100% recommended dose to 80% dose did not statistically affect the leaf area at various growth stages. Both the NF and WSF sources were on par with respect to leaf area in maize.

Though not significant, higher leaf area ($535 \text{ cm}^2 - 5821 \text{ cm}^2$) was obtained with either NF or WSF at 100% recommended dose in fertigation while application of NF or WSF at 80% recommended dose in furrow method had the lowest leaf area ($458 \text{ cm}^2 - 5124 \text{ cm}^2$) at all growth stages.

Table-4.16 : Leaf area in maize as influenced by methods of irrigation, levels and sources of fertilizer during 1994 and 1996

Treatments	Leaf area(cm ² /plant)					
	30 DAS		60 DAS		90 DAS	
	1994	1996	1994	1996	1994	1996
Main treatments						
Irrigation methods						
I ₁ Furrow	466.2	483.9	5131.2	5218.7	3929.5	3911.6
I ₂ Drip	506.3	510.2	5623.7	5593.8	4278.2	4207.8
I ₃ Fertigation	528.6	525.8	5791.7	5735.1	4495.4	4326.5
F test	NS	*	*	*	*	*
C.D at 5%	-	20.8	390.1	343.1	320.2	296.0
Fertilizer levels						
L ₁ 80% Rec. dose	491.5	497.1	5387.5	5439.9	4179.5	4098.6
L ₂ 100% Rec. dose	509.3	516.2	5643.6	5591.9	4289.3	4198.6
F test	NS	NS	NS	NS	NS	NS
C.D at 5%	-	-	-	-	-	-
Fertilizer sources						
S ₁ NF	500.6	505.8	5473.7	5518.8	4232.9	4143.5
S ₂ WSF	500.2	507.6	5557.4	5512.9	4235.8	4153.8
F test	NS	NS	NS	NS	NS	NS
C.D at 5%	-	-	-	-	-	-
Combined treatments						
Furrow irrigation						
T ₁ 80% Rec. dose NF	459.5	466.9	4909.8	5173.5	3855.5	3809.5
T ₂ 80% Rec. dose WSF	458.6	477.4	5013.4	5124.7	3817.3	3857.6
T ₃ 100% Rec. dose NF	467.8	488.3	5245.6	5268.4	3975.2	4017.6
T ₄ 100% Rec. dose WSF	479.1	503.2	5356.1	5308.2	4070.0	3961.7
Drip irrigation						
T ₅ 80% Rec. dose NF	498.5	488.8	5455.4	5535.2	4220.1	4181.5
T ₆ 80% Rec. dose WSF	490.3	501.5	5456.1	5479.8	4180.6	4128.9
T ₇ 100% Rec. dose NF	515.3	530.3	5649.5	5657.5	4390.8	4277.6
T ₈ 100% Rec. dose WSF	521.1	520.2	5933.8	5702.7	4321.3	4243.2
Fertigation						
T ₉ 80% Rec. dose NF	527.2	529.3	5715.8	5685.2	4528.3	4276.5
T ₁₀ 80% Rec. dose WSF	514.8	518.6	5774.4	5640.9	4475.2	4337.8
T ₁₁ 100% Rec. dose NF	535.3	531.2	5866.3	5793.2	4427.9	4298.1
T ₁₂ 100% Rec. dose WSF	537.1	524.2	5810.2	5821.2	4550.4	4393.6
WSF	NS		NS	NS	NS	NS
F test	-		-	-	-	-
C.D. at 5%						

Rec. Dose=150:75:50kg N:P₂O₅:K₂O/ha
DAS = Days after sowing

* = Significant
NS = Non-significant

NF = Normal fertilizer
WSF = Water soluble fertilizer

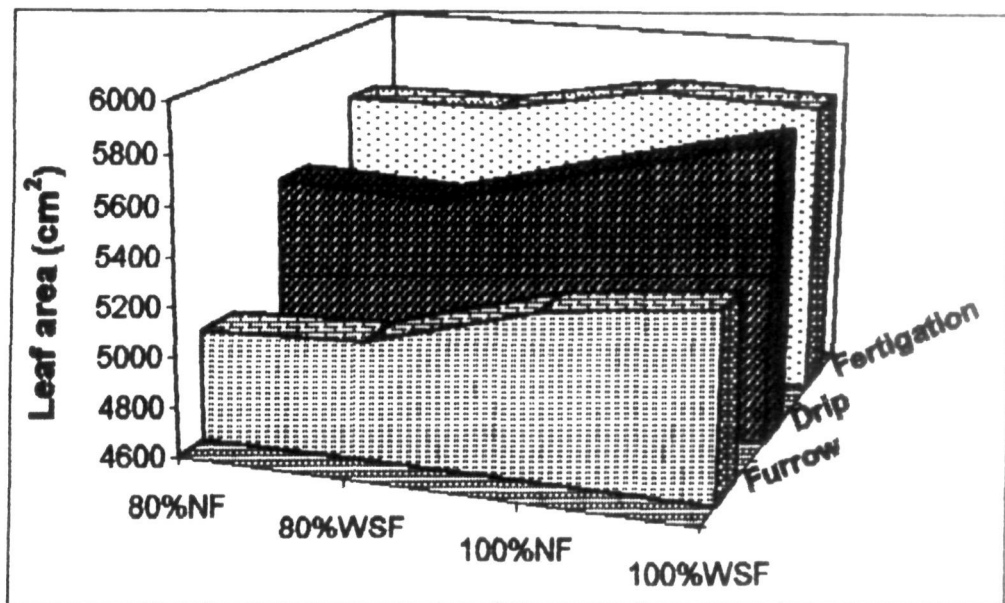

Fig. 4.6 : Leaf area in maize at 60DAS as influenced by fertigation, drip and furrow with levels and sources of fertilizer (mean of two years)

4.4.3 Number of leaves per plant

Data on number of leaves at 60 days after sowing as influenced by methods of irrigation, levels and sources of fertilizer during 1994 and 1996 are presented in Table-4.17.

Number of leaves per plant differed significantly due to direct effect of irrigation methods. Maximum number of leaves (13.4 and 13.5 in 1994 and 1996 respectively) recorded with fertigation treatment was significantly superior to 12.1 (1994) and 12.6 (1996) leaves per plant recorded with furrow method but statistically equal to 12.8 (1994) and 13.1 (1996) leaves observed in drip irrigated maize.

Reduced fertilizer level (80%) or NF source did not bring changes in the number of leaves as compared to 100% fertilizer level or WSF source respectively. The variation in number of leaves from 11.8-13.6 leaves per plant showed no interaction effects both in 1994 and 1996.

4.4.4 Leaf Area Index (LAI) in maize

Leaf area index as influenced by methods of irrigation levels and sources of fertilizer at 30, 60 and 90 DAS is presented in Table-4.18.

Leaf area index in maize showed significant variation under the influence of irrigation methods except at 30 DAS to 90 DAS during 1994. LAI values obtained with fertigation from 30 to 90 DAS (0.29 TO 3.12/plant) were significantly superior to corresponding values 0.26 to 2.90 recorded with furrow treatment. However, LAI of 0.28 to 3.10 per plant produced by drip irrigated maize was on par with both fertigation furrow treatments.

Table-4.17 : Number of leaves per plant in maize at 60 days after sowing as influenced by methods of irrigation, levels and sources of fertilizer during 1994 and 1996

Treatments	Number of leaves/plant						
	1994			1996			
	80% Rec. dose (L ₁)	100% Rec. dose (L ₂)	Mean	80% Rec. dose (L ₁)	100% Rec. dose (L ₂)	Mean	
Main treatments							
Irrigation methods							
I ₁ Furrow	11.8	12.4	12.1	12.3	12.8	12.6	
I ₂ Drip	12.5	13.1	12.8	12.8	13.4	13.1	
I ₃ Fertigation	13.3	13.4	13.4	13.5	13.5	13.5	
Mean	12.6	13.0		12.9	13.2		
Fertilizer sources							
S ₁ NF	12.6	12.9	12.7	12.9	13.3	13.1	
S ₂ WSF	12.6	13.1	12.8	12.9	13.2	13.1	
Mean	12.6	13.0		12.9	13.2		
Irrigation methods							
I ₁ Furrow			12.1			12.6	
I ₂ Drip	12.2	12.1	12.8	12.6	12.6	13.1	
I ₃ Fertigation	12.7	12.9	13.4	13.1	13.1	13.5	
Mean	13.3	13.4		13.4	13.6		
	12.7	12.8		13.1	13.1		
	I ₁	I ₂	I ₃	I ₁	I ₂	I ₃	
L ₁ -100%R.D.	S ₁ -NF	11.9	12.6	13.3	12.3	12.8	13.5
	S ₂ -WSF	11.8	12.5	13.4	12.3	12.9	13.5
L ₂ - 80%R.D.	S ₁ -NF	12.5	12.9	13.3	12.9	13.5	13.4
	S ₂ -WSF	12.4	13.3	13.5	12.8	13.3	13.6
	F-test	C.D at 5%		F-test	C.D at 5%		
I	*	0.7		*	0.7		
L	NS	-		NS	-		
S	NS	-		NS	-		
I x L	NS	-		NS	-		
L x S	NS	-		NS	-		
I x S	NS	-		NS	-		
I x L x S	NS	-		NS	-		

Rec. Dose=150:75:50kg N:P₂O₅:K₂O/ha
DAS = Days after sowing

* = Significant
NS = Non-significant

NF = Normal fertilizer
WSF = Water soluble fertilizer

Table-4.18 : Leaf area index in maize as influenced by methods of irrigation, levels and sources of fertilizer during 1994 and 1996

Treatments	Leaf area index					
	30 DAS		60 DAS		90 DAS	
	1994	1996	1994	1996	1994	1996
Main treatments						
Irrigation methods						
I ₁ Furrow	0.26	0.27	2.84	2.90	2.18	2.17
I ₂ Drip	0.28	0.28	3.12	3.10	2.37	2.34
I ₃ Fertigation	0.29	0.29	3.22	3.18	2.45	2.40
F test	NS	*	*	*	*	*
C.D at 5%	-	.01	0.31	0.18	0.19	0.17
Fertilizer levels						
L ₁ 80% Rec. dose	0.27	0.27	2.99	3.02	2.32	2.27
L ₂ 100% Rec. dose	0.28	0.28	3.13	3.11	2.38	2.33
F test	NS	NS	NS	NS	NS	NS
C.D at 5%	-	-	-	-	-	-
Fertilizer sources						
S ₁ NF	0.28	0.28	3.04	3.06	2.35	2.30
S ₂ WSF	0.28	0.28	3.09	3.06	2.34	2.31
F test	NS	NS	NS	NS	NS	NS
C.D at 5%	-	-	-	-	-	-
Combined treatments						
Furrow irrigation						
T ₁ 80% Rec. dose NF	0.25	0.26	2.72	2.87	2.14	2.11
T ₂ 80% Rec. dose WSF	0.25	0.26	2.78	2.85	2.12	2.14
T ₃ 100% Rec. dose NF	0.26	0.27	2.91	2.93	2.21	2.23
T ₄ 100% Rec. dose WSF	0.27	0.28	2.97	2.95	2.26	2.20
Drip irrigation						
T ₅ 80% Rec. dose NF	0.28	0.27	3.03	3.07	2.34	2.32
T ₆ 80% Rec. dose WSF	0.27	0.28	3.03	3.04	2.32	2.29
T ₇ 100% Rec. dose NF	0.29	0.29	3.14	3.14	2.44	2.38
T ₈ 100% Rec. dose WSF	0.29	0.29	3.30	3.17	2.40	2.36
Fertigation						
T ₉ 80% Rec. dose NF	0.29	0.29	3.17	3.16	2.51	2.37
T ₁₀ 80% Rec. dose WSF	0.29	0.29	3.21	3.13	2.49	2.41
T ₁₁ 100% Rec. dose NF	0.30	0.29	3.26	3.22	2.46	2.39
T ₁₂ 100% Rec. dose WSF	0.30	0.29	3.23	3.23	2.53	2.44
WSF	NS	NS	NS	NS	NS	NS
F test	-	-	-	-	-	-
C.D. at 5%	-	-	-	-	-	-

Rec. Dose=150:75:50kg N:P₂O₅:K₂O/ha
DAS = Days after sowing

* = Significant
NS = Non-significant

NF = Normal fertilizer
WSF = Water soluble fertilizer

Fertilizer levels on sources did not produce significant response in terms of LAI in maize at any stage or year. Likewise, difference in LAI values of 0.25 to 0.30 at 30 DAS, 2.72 to 3.26 at 60 DAS and 2.11 to 2.53 at 90 DAS were not statistically significant.

4.4.5 Total dry matter in maize

Data on total dry matter accumulation (DMA) at 30, 60, 90 DAS and at harvest as influenced by methods of irrigation, levels and sources of fertilizers are presented in Table-4.19.

DMA was considerably influenced by main effect of irrigation methods. Significant increase in DMA was associated with fertigation treatment at all growth stages viz., 30, 60, 90 DAS and at harvest except at 30 DAS in 1994. DMA in fertigation at these growth phases ranged from 3.86 to 223.75 g plant⁻¹ in both the years 1994 and 1996 compared to 3.75 g – 209.76 g plant⁻¹ obtained with drip method. Furrow irrigated maize showed significantly lower DMA of 3.62 g – 190.56 g plant⁻¹ at all growth stages compared to fertigation (Fig. 4.7).

The effect of fertilizer levels on the total dry matter per plant was significant at 30 DAS in 1996, 90 DAS in 1994 and at harvest in 1996. The 100% recommended dose at these stages registered higher DMA (3.82g, 139.97g and 213.8 g plant⁻¹) compared to the 80% level (3.66 g, 122.81 g and 202.24 g plant⁻¹ correspondingly). Fertilizer sources did not significantly influence DMA at any stage. Interactions among different factors and their levels also showed no significant effect on DMA in maize.

Table 4.19 : Total dry matter accumulation in maize as influenced by methods of irrigation, levels and sources of fertilizer during 1994 and 1996

Treatments	Total dry matter accumulation (g/plant)							
	30 DAS		60 DAS		90 DAS		At Harvest	
	1994	1996	1994	1996	1994	1996	1994	1996
Main treatments								
Irrigation methods								
I ₁ Furrow	3.66	3.62	68.57	72.76	110.51	116.98	185.18	190.18
I ₂ Drip	3.82	3.75	84.20	86.34	132.85	136.06	203.94	209.18
I ₃ Fertigation	3.93	3.86	94.49	93.43	150.78	148.88	218.46	223.18
F test	NS	*	*	*	*	*	*	*
C.D at 5%	-	0.15	10.95	14.45	25.33	24.02	19.74	14.18
Fertilizer levels								
L ₁ 80% Rec. dose	3.78	3.66	78.46	80.37	122.81	124.74	196.36	202.18
L ₂ 100% Rec. dose	3.84	3.82	86.39	87.98	139.97	143.88	208.69	213.18
F test	NS	*	NS	NS	*	NS	NS	*
C.D at 5%	-	0.12	-	-	16.84	-	-	11.18
Fertilizer sources								
S ₁ NF	3.80	3.73	82.70	83.89	131.50	132.64	202.32	207.18
S ₂ WSF	3.80	3.76	82.18	84.46	131.28	135.97	202.73	208.18
F test	NS	NS	NS	NS	NS	NS	NS	NS
C.D at 5%	-	-	-	-	-	-	-	-
Combined treatments								
Furrow irrigation								
T ₁ 80% Rec. dose NF	3.60	3.51	65.71	67.08	101.52	104.79	177.57	184.18
T ₂ 80% Rec. dose WSF	3.65	3.56	66.20	69.25	103.81	108.18	180.32	182.18
T ₃ 100% Rec. dose NF	3.68	3.68	69.05	75.78	118.49	125.16	191.35	195.18
T ₄ 100% Rec. dose WSF	3.71	3.73	73.32	78.93	118.24	129.78	191.47	199.18
Drip irrigation								
T ₅ 80% Rec. dose NF	3.84	3.65	80.45	83.32	123.23	124.29	196.31	202.18
T ₆ 80% Rec. dose WSF	3.80	3.73	78.74	83.23	119.60	126.15	194.28	205.18
T ₇ 100% Rec. dose NF	3.84	3.84	90.85	90.08	145.17	147.15	213.83	216.18
T ₈ 100% Rec. dose WSF	3.80	3.78	86.96	88.72	143.54	150.65	211.36	214.18
Fertigation								
T ₉ 80% Rec. dose NF	3.87	3.72	91.72	91.05	145.40	141.20	213.51	221.18
T ₁₀ 80% Rec. dose WSF	3.85	3.81	87.92	88.32	143.31	143.82	216.16	217.18
T ₁₁ 100% Rec. dose NF	3.98	3.96	98.22	96.06	155.21	153.27	221.36	226.18
T ₁₂ 100% Rec. dose WSF	4.02	3.94	100.12	98.29	159.20	157.25	222.80	229.18
WSF	NS	NS	NS	NS	NS	NS	NS	NS
F test	-	-	-	-	-	-	-	-
C.D. at 5%	-	-	-	-	-	-	-	-

Rec. Dose=150:75:50kg N:P₂O₅:K₂O/ha
DAS = Days after sowing

* = Significant
NS = Non-significant

NF = Normal fertilizer
WSF = Water soluble fertilizer

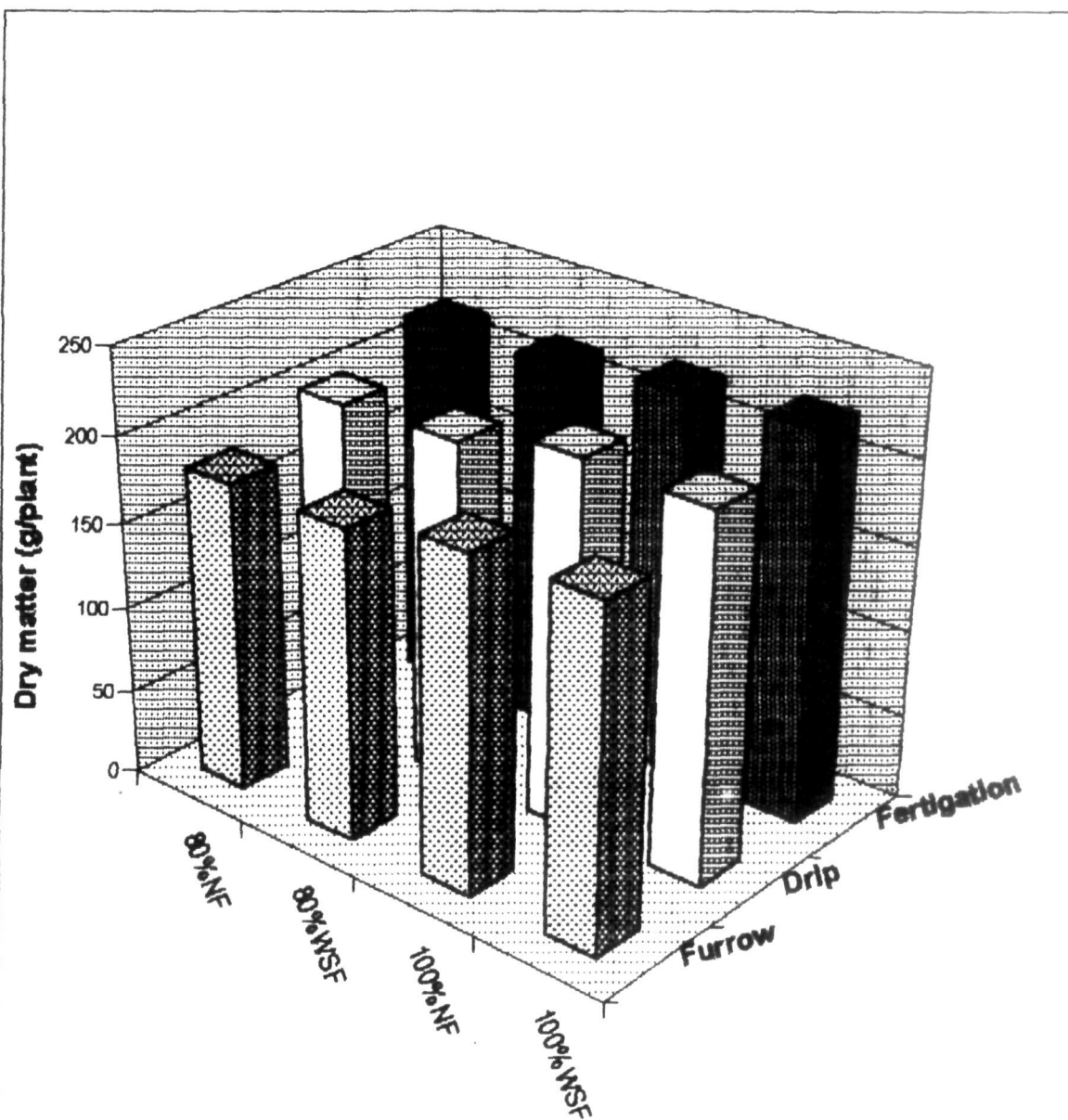

Fig. 4.7 : Dry matter (g/plant) at harvest in maize as influenced by fertigation, drip and furrow with levels and sources of fertilizer (mean of two years)

4.4.6 Drymatter distribution in maize

Data on dry matter distribution into stem, leaf, tassel, silk, cob sheath and cob at 30, 60, 90 DAS and at harvest as influenced by methods of irrigation, levels and sources of fertilizer are presented in Table-4.20.

Dry matter distribution at 30 DAS

Both stem and leaf dry matter was significantly influenced due to methods of irrigation. Fertigation treatment significantly increased stem dry matter from 1.31 g (1994) and 1.33 g (1996) in furrow to 1.38 g and 1.42 g respectively. Corresponding values 1.36 g and 1.39 g for drip method were on par to both fertigation and furrow irrigation. Leaf dry matter showed significant increase due to fertigation only in 1996 wherein the value was the highest (2.44 g plant⁻¹) compared to furrow treatment (2.29 g plant⁻¹).

Variations in dry matter distribution due to fertilizer levels or sources and interactions among treatment combinations were not significant.

Dry matter distribution at 60 DAS

Fertigation method produced significantly higher leaf, stem and cob dry matter in both the years and silk dry weight in 1996 (Table-4.20).

The leaf dry matter of 33.2 g and 32.7 g plant⁻¹ in 1994 and 1996 respectively obtained with fertigation was significantly superior to 23.6 g and 24.9 g plant⁻¹ respectively observed in furrow method but was on par with 29.3 g and 31.0 g plant⁻¹ leaf dry weight recorded with drip irrigated maize.

Table-4.20 : Dry matter distribution in maize as influenced by methods of irrigation, levels and sources of fertilizer during 1994 and 1996

Treatments	Dry matter distribution (g/plant)									
	30 DAS				60 DAS					
	Leaf		Stem		Leaf		Stem		Tassel	
	1994	1996	1994	1996	1994	1996	1994	1996	1994	1996
Main treatments										
Irrigation methods										
I ₁ Furrow	2.35	2.29	1.31	1.33	23.57	24.89	35.12	38.21	5.83	5.92
I ₂ Drip	2.46	2.36	1.36	1.39	29.26	31.03	43.74	44.37	6.39	6.44
I ₃ Fertigation	2.55	2.44	1.38	1.42	33.17	32.56	49.85	49.16	6.73	6.59
F test	NS	*	*	*	*	*	*	*	NS	NS
C.D at 5%	-	0.09	0.05	0.06	3.43	4.98	6.53	6.27	-	-
Fertilizer levels										
L ₁ 80% Rec. dose	2.43	2.32	1.32	1.34	26.62	26.99	40.89	41.51	6.18	6.26
L ₂ 100% Rec. dose	2.49	2.41	1.37	1.42	30.71	32.00	44.92	46.31	6.46	6.38
F test	NS	*	NS	*	*	*	*	NS	NS	NS
C.D at 5%	-	0.06	-	0.08	3.10	4.50	3.61	-	-	-
Fertilizer sources										
S ₁ NF	2.44	2.36	1.35	1.37	28.73	29.26	42.78	43.67	6.33	6.31
S ₂ WSF	2.46	2.37	1.35	1.39	28.60	29.73	43.03	44.16	6.30	6.32
F test	NS	NS	NS	NS	NS	NS	NS	NS	NS	NS
C.D at 5%	-	-	-	-	-	-	-	-	-	-
Combined treatments										
Furrow irrigation										
T ₁ 80% Rec. dose NF	2.27	2.20	1.30	1.31	21.86	22.27	34.27	36.27	5.63	5.81
T ₂ 80% Rec. dose WSF	2.35	2.27	1.27	1.29	22.93	24.39	33.56	34.18	5.71	5.87
T ₃ 100% Rec. dose NF	2.36	2.35	1.35	1.33	23.36	25.15	35.48	38.67	5.96	6.03
T ₄ 100% Rec. dose WSF	2.42	2.34	1.32	1.38	26.13	27.75	37.17	43.72	6.02	5.97
Drip irrigation										
T ₅ 80% Rec. dose NF	2.46	2.29	1.31	1.33	27.85	28.36	40.25	41.47	6.28	6.43
T ₆ 80% Rec. dose WSF	2.42	2.34	1.34	1.35	25.17	26.59	42.24	43.25	6.21	6.37
T ₇ 100% Rec. dose NF	2.46	2.41	1.41	1.46	33.36	35.17	47.10	46.50	6.64	6.44
T ₈ 100% Rec. dose WSF	2.50	2.40	1.38	1.42	30.66	34.00	45.39	46.26	6.43	6.54
Fertigation										
T ₉ 80% Rec. dose NF	2.52	2.38	1.35	1.35	32.37	31.16	46.50	47.35	6.65	6.51
T ₁₀ 80% Rec. dose WSF	2.47	2.42	1.38	1.41	29.56	29.15	48.51	46.24	6.57	6.57
T ₁₁ 100% Rec. dose NF	2.59	2.51	1.39	1.42	33.58	33.44	53.10	51.74	6.81	6.66
T ₁₂ 100% Rec. dose WSF	2.62	2.45	1.40	1.50	37.17	36.49	51.31	50.99	6.89	6.62
F test	NS	NS	NS	NS	NS	NS	NS	NS	NS	NS
C.D. at 5%	-	-	-	-	-	-	-	-	-	-

Rec. Dose=150:75:50kg N:P₂O₅:K₂O/ha
DAS = Days after sowing

* = Significant
NS = Non-significant

NF = Normal fertilizer
WSF = Water soluble fertilizer

Contd.

Table-4.20: (Contd.) Dry matter distribution in maize as influenced by methods of irrigation, levels and sources of fertilizer during 1994 and 1996

Treatments	Dry matter distribution (g/plant)									
	60 DAS					90 DAS				
	Silk		Cob sheath		Cob		Stem		Leaf	
	1994	1996	1994	1996	1994	1996	1994	1996	1994	1996
Main treatments										
Irrigation methods										
I ₁ Furrow	0.09	0.13	2.83	2.88	1.15	1.23	41.25	46.40	25.71	27.36
I ₂ Drip	0.11	0.14	3.20	3.23	1.36	1.42	49.26	49.94	30.26	32.04
I ₃ Fertigation	0.12	0.15	3.45	3.41	1.55	1.58	54.21	53.02	34.35	33.68
F test	NS	*	NS	NS	*	*	*	*	*	*
C.D at 5%	-	0.01	-	-	0.16	0.18	7.43	3.59	5.39	3.38
Fertilizer levels										
L ₁ 80% Rec. dose	0.10	0.13	3.09	3.12	1.32	1.38	44.29	47.66	27.88	29.36
L ₂ 100% Rec. dose	0.11	0.15	3.23	3.22	1.38	1.44	52.18	51.91	32.35	32.69
F test	NS	NS	NS	NS	NS	NS	NS	NS	NS	NS
C.D at 5%	-	-	-	-	-	-	-	-	-	-
Fertilizer sources										
S ₁ NF	0.11	0.14	3.17	3.18	1.35	1.42	48.70	49.62	30.31	31.08
S ₂ WSF	0.10	0.14	3.15	3.17	1.36	1.40	47.78	49.96	29.90	30.98
F test	NS	NS	NS	NS	NS	NS	NS	NS	NS	NS
C.D at 5%	-	-	-	-	-	-	-	-	-	-
Combined treatments										
Furrow irrigation										
T ₁ 80% Rec. dose NF	0.08	0.13	2.73	2.80	1.14	1.20	38.69	42.78	24.18	25.48
T ₂ 80% Rec. dose WSF	0.09	0.10	2.80	2.93	1.11	1.16	37.21	44.57	23.37	25.81
T ₃ 100% Rec. dose NF	0.09	0.14	2.99	2.95	1.17	1.26	45.21	49.51	28.10	29.61
T ₄ 100% Rec. dose WSF	0.10	0.14	2.82	3.20	1.18	1.30	43.87	48.74	27.19	28.54
Drip irrigation										
T ₅ 80% Rec. dose NF	0.13	0.13	3.12	3.20	1.31	1.39	42.58	49.18	27.74	28.84
T ₆ 80% Rec. dose WSF	0.10	0.14	3.17	3.15	1.34	1.36	45.51	47.37	25.39	30.06
T ₇ 100% Rec. dose NF	0.12	0.13	3.26	3.20	1.38	1.44	55.18	52.02	34.15	35.08
T ₈ 100% Rec. dose WSF	0.10	0.16	3.23	3.27	1.41	1.49	53.77	51.19	33.76	34.18
Fertigation										
T ₉ 80% Rec. dose NF	0.11	0.13	3.39	3.39	1.53	1.60	51.26	50.40	34.16	33.57
T ₁₀ 80% Rec. dose WSF	0.12	0.15	3.35	3.36	1.48	1.55	50.15	51.69	32.47	32.42
T ₁₁ 100% Rec. dose NF	0.13	0.16	3.55	3.45	1.55	1.61	58.91	53.82	33.55	33.88
T ₁₂ 100% Rec. dose WSF	0.12	0.16	3.51	3.44	1.62	1.56	56.16	56.19	37.22	34.85
F test	NS	NS	NS	NS	NS	NS	NS	NS	NS	NS
C.D. at 5%	-	-	-	-	-	-	-	-	-	-

Rec. Dose=150:75:50kg N:P₂O₅:K₂O/ha
DAS = Days after sowing

* = Significant
NS = Non-significant

NF = Normal fertilizer
WSF = Water soluble fertilizer

Contd.

Table-4.20: (Contd.) Dry matter distribution in maize as influenced by methods of irrigation, levels and sources of fertilizer during 1994 and 1996

Treatments	Dry matter distribution (g/plant)								At harvest	
	90 DAS									
	Tassel		Silk		Cob sheath		Cob		Stem	
	1994	1996	1994	1996	1994	1996	1994	1996	1994	1996
Main treatments										
Irrigation methods										
I ₁ Furrow	2.70	3.05	0.62	0.69	11.37	10.44	31.21	31.36	46.73	47.36
I ₂ Drip	3.19	3.49	0.74	0.73	14.05	14.37	36.14	36.09	49.96	51.80
I ₃ Fertigation	3.47	3.68	0.80	0.82	16.93	17.59	40.81	39.92	53.19	56.35
F test	*	NS	*	*	NS	*	*	*	NS	*
C.D at 5%	0.51	-	0.11	0.11	-	3.79	4.66	6.24	-	6.24
Fertilizer levels										
L ₁ 80% Rec. dose	3.09	3.32	0.70	0.71	12.48	12.02	33.49	33.57	48.00	50.20
L ₂ 100% Rec. dose	3.15	3.49	0.74	0.78	15.75	16.44	38.57	38.01	51.52	53.47
F test	NS	NS	NS	NS	NS	*	NS	NS	NS	NS
C.D at 5%	-	-	-	-	-	4.18	-	-	-	-
Fertilizer sources										
S ₁ NF	3.09	3.39	0.72	0.74	13.77	13.64	35.64	35.56	49.62	52.26
S ₂ WSF	3.18	3.43	0.72	0.75	14.47	14.62	36.41	36.01	50.30	51.42
F test	NS	NS	NS	NS	NS	NS	NS	NS	NS	NS
C.D at 5%	-	-	-	-	-	-	-	-	-	-
Combined treatments										
Furrow irrigation										
T ₁ 80% Rec. dose NF	2.55	2.93	0.61	0.63	8.55	8.87	26.40	28.50	43.85	46.54
T ₂ 80% Rec. dose WSF	2.80	3.00	0.59	0.67	10.04	7.31	28.94	28.86	44.96	44.36
T ₃ 100% Rec. dose NF	2.77	3.10	0.63	0.74	12.71	11.45	34.30	33.07	47.64	48.26
T ₄ 100% Rec. dose WSF	2.70	3.17	0.66	0.72	14.18	14.13	34.84	35.00	50.47	50.28
Drip irrigation										
T ₅ 80% Rec. dose NF	3.14	3.38	0.70	0.71	12.18	11.48	34.65	34.28	48.86	51.74
T ₆ 80% Rec. dose WSF	3.18	3.44	0.72	0.68	11.36	12.80	33.28	34.30	46.75	48.26
T ₇ 100% Rec. dose NF	2.95	3.61	0.79	0.75	17.09	16.06	37.38	38.41	51.05	53.35
T ₈ 100% Rec. dose WSF	3.48	3.53	0.75	0.78	15.57	17.14	39.25	37.37	53.18	53.86
Fertigation										
T ₉ 80% Rec. dose NF	3.40	3.56	0.77	0.78	15.70	15.15	38.56	36.36	51.26	55.95
T ₁₀ 80% Rec. dose WSF	3.45	3.60	0.81	0.82	17.08	16.52	39.12	39.12	52.35	54.37
T ₁₁ 100% Rec. dose NF	3.54	3.74	0.82	0.85	16.37	18.84	42.53	42.74	55.07	57.71
T ₁₂ 100% Rec. dose WSF	3.45	3.82	0.81	0.83	18.57	19.85	43.04	41.45	54.10	57.37
F test	NS	NS	NS	NS	NS	NS	NS	NS	NS	NS
C.D. at 5%	-	-	-	-	-	-	-	-	-	-

Rec. Dose=150:75:50kg N:P₂O₅:K₂O/ha
DAS = Days after sowing

* = Significant
NS = Non-significant

NF = Normal fertilizer
WSF = Water soluble fertilizer

Contd.

Table-4.20: (Contd.) Dry matter distribution in maize as influenced by methods of irrigation, levels and sources of fertilizer during 1994 and 1996

Treatments	Dry matter distribution (g/plant)									
	At harvest									
	Leaf		Tassel		Silk		Cob sheath		Cob	
	1994	1996	1994	1996	1994	1996	1994	1996	1994	1996
Main treatments										
Irrigation methods										
I ₁ Furrow	17.74	18.98	2.83	2.90	0.57	0.59	13.65	12.97	105.73	110.2
I ₂ Drip	20.32	21.76	3.41	3.41	0.66	0.55	16.06	15.75	114.77	117.5
I ₃ Fertigation	23.65	23.47	3.50	3.55	1.71	0.68	17.83	18.38	120.86	122.2
F test	*	NS	NS	NS	NS	NS	*	*	*	*
C.D at 5%	2.97	-	-	-	-	-	2.13	2.81	8.52	7.51
Fertilizer levels										
L ₁ 80% Rec. dose	19.31	20.33	3.17	3.24	0.62	0.62	14.54	14.63	115.40	114.4
L ₂ 100% Rec. dose	21.83	22.47	3.32	3.33	0.67	0.65	17.15	16.68	116.03	118.8
F test	NS	NS	NS	NS	NS	NS	*	NS	NS	NS
C.D at 5%	-	-	-	-	-	-	2.53	-	-	-
Fertilizer sources										
S ₁ NF	20.29	21.31	3.25	3.29	0.64	0.63	15.94	15.36	114.15	116.4
S ₂ WSF	20.85	21.50	3.24	3.29	0.65	0.64	17.77	16.04	113.43	116.8
F test	NS	NS	NS	NS	NS	NS	NS	NS	NS	NS
C.D at 5%	-	-	-	-	-	-	-	-	-	-
Combined treatments										
Furrow irrigation										
T ₁ 80% Rec. dose NF	16.57	18.28	2.78	2.87	0.55	0.56	11.66	11.05	102.45	106.6
T ₂ 80% Rec. dose WSF	15.05	17.63	2.70	2.84	0.53	0.56	12.34	11.47	105.16	108.7
T ₃ 100% Rec. dose NF	20.19	19.67	2.89	2.94	0.59	0.60	15.47	15.19	108.53	111.3
T ₄ 100% Rec. dose WSF	19.15	20.34	2.95	2.94	1.61	0.64	15.11	14.17	106.78	114.1
Drip irrigation										
T ₅ 80% Rec. dose NF	18.16	19.35	3.32	3.34	0.62	0.63	13.74	13.56	112.94	115.2
T ₆ 80% Rec. dose WSF	19.87	21.93	3.30	3.31	0.64	0.65	15.22	15.18	110.36	115.5
T ₇ 100% Rec. dose NF	21.94	22.87	3.48	3.48	0.71	0.66	18.16	17.77	119.52	120.7
T ₈ 100% Rec. dose WSF	21.30	22.89	3.54	3.51	0.67	0.65	17.12	16.50	116.26	118.5
Fertigation										
T ₉ 80% Rec. dose NF	22.36	23.17	3.48	3.55	0.69	0.68	17.56	17.10	118.57	121.1
T ₁₀ 80% Rec. dose WSF	23.84	21.65	3.45	3.53	0.71	0.66	16.71	19.43	119.76	119.2
T ₁₁ 100% Rec. dose NF	22.53	24.50	3.56	3.55	0.71	0.67	18.95	17.50	122.87	123.5
T ₁₂ 100% Rec. dose WSF	25.87	24.56	3.51	3.58	0.73	0.70	18.11	19.47	122.24	125.0
F test	NS	NS	NS	NS	NS	NS	NS	NS	NS	NS
C.D. at 5%	-	-	-	-	-	-	-	-	-	-

Rec. Dose=150:75:50kg N:P₂O₅:K₂O/ha
DAS = Days after sowing

* = Significant
NS = Non-significant

NF = Normal fertilizer
WSF = Water soluble fertilizer

The corresponding dry matter values for stem (49.8 g and 49.2 g) and cob (1.5 g and 1.6 g) were also significantly superior to furrow method (35.1 g, 38.2 g, 1.1 g and 1.2 g respectively). However, dry matter in tassel and cob sheath in both years and silk in 1994 did not respond significantly due to irrigation treatments.

Fertilizer level at 100% significantly increased leaf dry weight in both the years (30.7 g and 32.0 g plant⁻¹) and stem dry matter in 1994 (44.9 g plant⁻¹) as compared to 80% level (26.6 g and 27.0 g leaf dry weight and 40.9 g stem dry weight correspondingly).

The dry matter distribution in tassel, silk, cob sheath or cob was not affected by reducing fertilizer level by 20% in both the years.

Differences noticed in terms of dry matter distribution due to fertilizer sources were not statistically significant. Likewise, combined effect of different treatments did not cause significant response with respect to dry matter partition into different plant parts.

Dry matter distribution at 90 DAS

Dry matter distribution was significantly influenced by direct effect of irrigation methods barring tassel dry matter in 1996 and cob sheath dry weight in 1994. The highest dry matter values 54.21 g (1994) and 53.02 g (1996) in stem, 34.35 g (1994) and 33.68 g (1996) in leaf, 3.47 g (1994) in tassel, 0.80 g (1994) and 0.82 g (1996) in silk, 17.59 (1996) in cob sheath and 40.89 g (1994) and 39.92 g (1996) in cob were significantly superior to furrow method which produced 41.25 g (1994) and 46.40 g(1996) stem dry matter, 25.71 g (1996) leaf dry matter, 2.70 g (1996) tassel dry matter, 0.62 g (1994) and 0.69 g (1996) silk dry weight, 10.41 g (1996) cob sheath dry weight, 31.21 g (1994) and 31.36 g (1996), cob dry matter respectively. The drip treatment was also

significantly superior to furrow method with respect to dry matter in stem during 1994, leaf in 1996, silk in 1994, cob sheath in 1996 and cob dry matter in 1994.

The dry matter partition did not vary significantly between the full dose (100%) and reduced dose (80%) or NF and WSF sources except fertilizer level on cob sheath in 1996 where full dose produced $16.24 \text{ g plant}^{-1}$ compared to $12.02 \text{ g plant}^{-1}$ with 80% dose. Sources of WSF and NF produced identical dry matter distribution in all plant parts.

Variations in dry matter partition due to interaction among main factors and their levels were not found significant.

Dry matter distribution at harvest

The data presented in Table 4.20 indicated that fertigation influenced the dry matter distribution in 1996 in stem (56.35 g), leaf (23.65 g) and cob sheath and in both the years in (17.83 and 18.38 g) and cob (120.8 and 122.2 g) compared to furrow irrigation (47.36 g of stem, 17.74 g of leaf in 1996 and 13.65 g and 12.97 g of cob sheath, 105.73 and 110.21 g plant^{-1} of cob in 1994 and 1996 correspondingly. The drip method was also significantly superior to furrow with respect to cob dry weight ($114.77 \text{ g plant}^{-1}$) only in 1994 but was on par with either fertigation or furrow irrigation in the remaining stages and years.

The 100% fertilizer dose had higher dry weight of cob sheath (17.1 g) compared to 80% level (14.5 g). All other plant parts were not influenced by fertilizer levels.

Sources WSF or NF did bring any significant changes in dry weight of plant parts in maize at harvest. Interactions among treatments were absent.

4.4.7 Days taken for 50% tasselling and 50% silking in maize

Data on number of days taken for 50% tasselling and 50% silking in maize as influenced by methods of irrigation, levels and sources of fertilizer are presented in Table-4.21.

Days taken for 50% tasselling was significantly influenced by methods of irrigation only in 1996 wherein fertigation advanced tasselling by two days and one day than observed with furrow method (62.1 days) and drip method (61.2 days) respectively.

However, variations in number of days taken for 50% tasselling due to levels or sources of fertilizer and their interaction were not significant. Similarly, days taken for 50 silking did not differ significantly due to different treatments under study.

4.5 Yield and its components in maize

4.5.1 Grain and stover yield of maize (kg ha^{-1})

Data on grain and stover yield of maize as influenced by methods of irrigation levels and sources of fertilizer are furnished in Table-4.22.

Maize grain yield was significantly influenced by methods of irrigation both in 1994 and 1996. Highest yield of 4757 and 4716 kg ha^{-1} in 1994 and 1996 respectively was recorded in fertigation treatment which was at par with the yield in drip method (4485 g and 4514 kg ha^{-1}) but significantly higher than furrow irrigation (4157 kg and 4239 kg ha^{-1}) (Fig. 4.8).

Fertilizer dose at 100% was superior in grain yield significantly only in 1994 (4545 kg ha^{-1}) compared to the reduced dose of 80% (4388 kg ha^{-1}). During 1996, no significant

Table-4.21: Days taken for 50% tasseling and 50% silking in maize as influenced by methods of irrigation, levels and sources of fertilizer during 1994 and 1996

Treatments	Days taken for 50% tasseling		Days taken for 50% silking	
	1994	1996	1994	1996
Main treatments				
Irrigation methods				
I ₁ Furrow	61.4	62.1	63.7	64.0
I ₂ Drip	60.8	61.2	63.4	62.4
I ₃ Fertigation	59.5	54.8	62.7	61.7
F test	NS	*	NS	NS
C.D at 5%	-	1.24	-	-
Fertilizer levels				
L ₁ 80% Rec. dose	60.9	61.4	63.7	63.2
L ₂ 100% Rec. dose	60.3	60.7	63.0	62.2
F test	NS	NS	NS	NS
C.D at 5%	-	-	-	-
Fertilizer sources				
S ₁ NF	61.2	61.0	63.3	62.4
S ₂ WSF	59.9	61.1	63.3	62.1
F test	NS	NS	NS	NS
C.D at 5%	-	-	-	-
Combined treatments				
Furrow irrigation				
T ₁ 80% Rec. dose NF	61.7	62.5	64.7	63.3
T ₂ 80% Rec. dose WSF	62.3	63.4	63.8	65.5
T ₃ 100% Rec. dose NF	62.4	61.7	62.3	64.4
T ₄ 100% Rec. dose WSF	59.4	60.9	64.2	62.8
Drip irrigation				
T ₅ 80% Rec. dose NF	60.4	61.8	64.5	62.2
T ₆ 80% Rec. dose WSF	61.5	59.9	63.8	63.1
T ₇ 100% Rec. dose NF	62.3	60.6	62.6	62.0
T ₈ 100% Rec. dose WSF	58.9	62.5	62.9	62.4
Fertigation				
T ₉ 80% Rec. dose NF	60.3	61.3	63.0	61.7
T ₁₀ 80% Rec. dose WSF	59.2	59.7	62.2	63.2
T ₁₁ 100% Rec. dose NF	60.1	58.4	62.7	60.8
T ₁₂ 100% Rec. dose WSF	58.5	60.0	63.1	61.1
F test	NS	NS	NS	NS
C.D. at 5%	-	-	-	-

Rec. Dose=150:75:50kg N:P₂O₅:K₂O/ha
DAS = Days after sowing

* = Significant
NS = Non-significant

NF = Normal fertilizer
WSF = Water soluble fertilizer

differences were observed in grain yield of maize with the two levels of fertilizers (4433 and 4546 kg ha⁻¹).

Grain yield did not differ significantly during both the years due to forms of fertilizers (4466 to 4496 kg ha⁻¹).

No interaction was found significant in influencing the grain yield.

Stover yield did not differ significantly due to methods of irrigation or levels or sources of fertilizers in the first year (1994). However, it was significantly higher (5615 kg ha⁻¹) in fertigated maize than furrow (5427 kg ha⁻¹) but was on par with drip method (5523 kg ha⁻¹) during 1996 (Table-4.22) (Fig.4.9). During that year, stover yield increased from 5449 kg ha⁻¹ in reduced dose (80%) to 5594 kg ha⁻¹ with full dose 100%.

This parameter was not influenced by either source of fertilizer or the interaction between fertilizer and irrigation in both the years although the values varied between 5289 kg ha⁻¹ and 5745 kg ha⁻¹.

4.5.2 Yield attributes in maize

Data on yield components in maize as influenced by method of irrigation, levels and sources of fertilizer are presented in Table-4.23.

Yield components exhibited significant response to methods of irrigation. The number of grains (37.3) per row and number of grains per cob (505) were significantly higher in the fertigation treatment in 1994 than the furrow irrigated maize which resulted in 32.1 grains row⁻¹ and 467 grains cob⁻¹ respectively. Significantly higher grain weight per cob (127 g and 128 g in 1994

Table-4.22 : Grain yield and stover yield (kg/ha) in maize as influenced by methods of irrigation, levels and sources of fertilizer during 1994 and 1996

Treatments	Green yield (kg/ha)						Stover yield (kg/ha)					
	1994			1996			1994			1996		
	80%RD (L ₁)	100%RD (L ₂)	Mean	80%RD (L ₁)	100%RD (L ₂)	Mean	80%RD (L ₁)	100%RD (L ₂)	Mean	80%RD (L ₁)	100%RD (L ₂)	Mean
Mean treatments												
I ₁ Furrow	4154	4160	4157	4209	4269	4239	5317	5450	5384	5431	5422	5427
I ₂ Drip	4499	4471	4485	4424	4603	4514	5451	5522	5502	5523	5523	5523
I ₃ Fertigation	4752	4814	4757	4666	4765	4716	5506	5650	5578	5561	5668	5615
Mean	4388	4545	4433	4433	4546	4484	5425	5551	5449	5449	5594	5595
S ₁ NF	4393	4544	4468	4428	4539	4484	5423	5545	5484	5431	5580	5538
S ₂ WSF	4382	4546	4464	4438	4553	4496	5427	5557	5492	5467	5609	5538
Mean	4388	4545	4433	4433	4546	4484	5425	5551	5449	5449	5594	5538
I ₁ Furrow	NF(S1)	WSF(S2)	NF(S1)	WSF(S2)	WSF(S2)	NF(S1)	NF(S1)	WSF(S2)	NF(S1)	WSF(S2)	WSF(S2)	NF(S1)
I ₂ Drip	4154	4160	4157	4263	4214	4239	5403	5365	5384	5431	5422	5427
I ₃ Fertigation	4499	4471	4485	4495	4532	4514	5479	5525	5502	5523	5523	5523
Mean	4752	4761	4757	4692	4740	4716	5570	5586	5578	5561	5668	5615
	4468	4464	4464	4484	4496	4484	5484	5492	5505	5505	5538	5538
L ₁ 100%RD	I ₁	I ₂	I ₃	I ₁	I ₂	I ₃	I ₁	I ₂	I ₃	I ₁	I ₂	I ₃
L ₂ 80%RD	4075	4380	4724	4225	4421	4639	5337	5425	5508	5289	5467	5536
	4066	4407	4674	4193	4428	4694	5298	5478	5505	5373	5436	5592
	4233	4618	4781	4302	4570	4745	5469	5533	5633	5574	5579	5587
	4255	4535	4848	4236	4637	4786	5432	5572	5667	5472	5610	5745
	F-test	C.D. at 5%	F-test	F-test	C.D. at 5%	F-test	F-test	C.D. at 5%	F-test	C.D. at 5%	F-test	C.D. at 5%
I	*	339	*	*	317	NS	NS	-	NS	-	125	-
L	*	131	NS	NS	-	NS	NS	-	*	-	97	-
S	NS	-	NS	NS	-	NS	NS	-	NS	-	-	-
I x L	NS	-	NS	NS	-	NS	NS	-	NS	-	-	-
L x S	NS	-	NS	NS	-	NS	NS	-	NS	-	-	-
I x S	NS	-	NS	NS	-	NS	NS	-	NS	-	-	-
I x L x S	NS	-	NS	NS	-	NS	NS	-	NS	-	-	-

Rec. Dose=150:75:50 kg N:P₂O₅:K₂O/ha DAS = Days after sowing * = Significant NS = Non-significant NF = Normal fertilizer WSF = Water soluble fertilizer

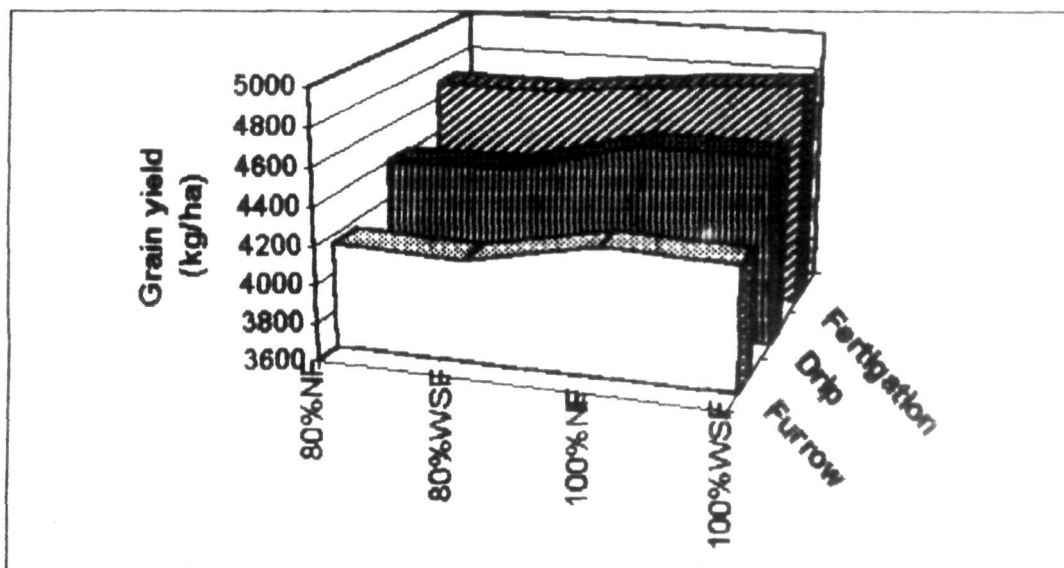

Fig. 4.8 : Grain yield (kg/ha) in maize as influenced by fertigation, drip and furrow with levels and sources of fertilizer (mean of two years)

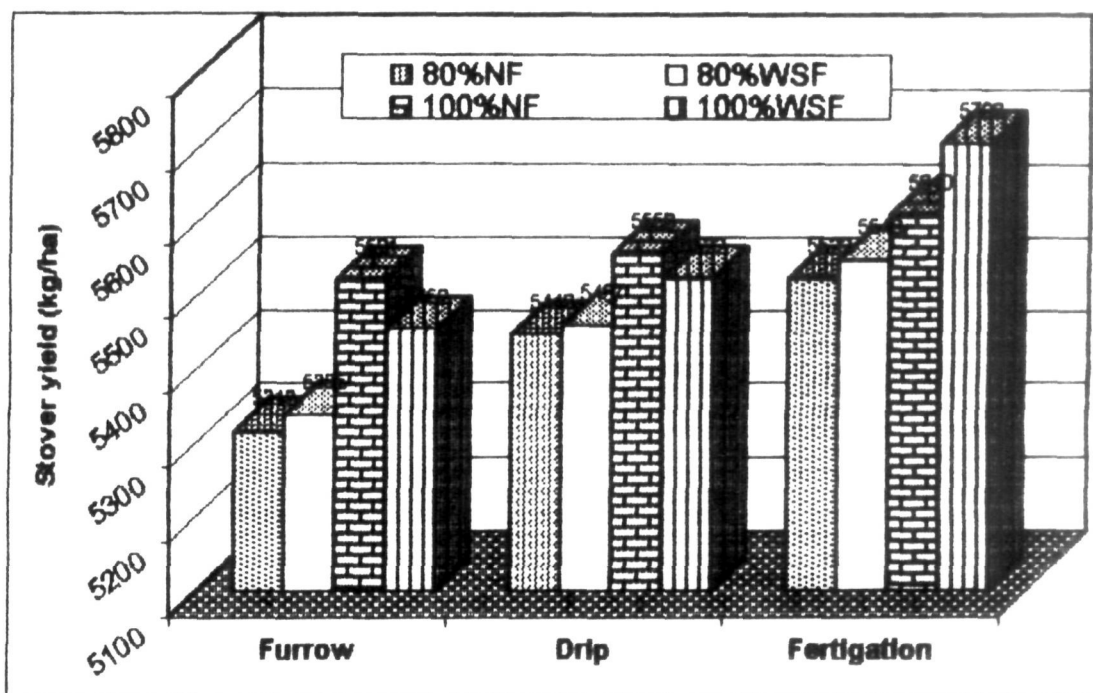

Fig 4.9 :Stover yield (kg/ha) in maize as influenced by fertigation, drip and furrow with levels and sources of fertilizer (mean of two years)

and 1996 respectively) and test weight (258 g and 257 g in 1994 and 1996 respectively) were also recorded under fertigation than with furrow method (108 g, 113 g, 233 g and 237 g correspondingly). Drip irrigation improved these parameters than obtained with furrow treatment but not significantly except grain weight per cob (120 g) in 1994.

Cob length (19.54 cm) in 1996 and cob girth in both the years (16.77 and 17.00 cm) were significantly superior due to fertigation than with furrow method (18.54 cm, 15.32 cm and 15.78 cm correspondingly) but was on par with drip method (19.88 cm, 16.20 cm and 16.65 cm respectively). The shelling per cent was insignificantly higher with fertigation than drip and furrow in both the years.

However, the prolificity per cent 6.6 (1994) and 6.9 (1996) with fertigation was significantly superior to furrow irrigation (5.0% and 5.5% respectively) but statistically equal to drip treatment only in 1994 (6.2%).

Higher fertilizer dose (100%) significantly influenced the grain number per row (35.8) and grain number per cob (500) both in 1994 and cob length (20.40 cm) in 1996 as compared to the lower dose (80%) which registered lower values for these parameters (33.6, 474 and 18.78 correspondingly). However, the full dose resulted in insignificantly higher value for all other yield attributes viz. grain weight per cob, test weight, cob girth, shelling and prolificity per cent.

The WSF source improved most of the yield components marginally but not significantly. So also, the interaction among irrigation methods, levels and sources of fertilizer was not considerable on different yield attributes.

Table-4.23: Yield attributes in maize as influenced by method of irrigation levels and sources of fertilizer during 1994 and 1996

Treatments	Grain number/row		Grain number/cob		Grain weight/cob (g)		100 seed weight (g)	
	1994	1996	1994	1996	1994	1996	1994	1996
Main treatments								
Irrigation methods								
I ₁ Furrow	32.1	33.8	467.0	475.3	108	113	233.5	237.2
I ₂ Drip	34.7	35.2	488.6	487.5	120	122	248.7	251.5
I ₃ Fertigation	37.3	37.1	505.0	498.7	127	128	257.7	256.8
F test	*	NS	*	NS	*	*	*	*
C.D at 5%	3.7	-	23.6	-	11.0	11.0	17.7	14.7
Fertilizer levels								
L ₁ 80% Rec. dose	33.6	34.2	474.1	480.9	114	118	241.9	244.8
L ₂ 100% Rec. dose	35.8	36.5	499.7	493.4	123	124	251.5	252.2
F test	*	NS	*	NS	NS	NS	NS	NS
C.D at 5%	1.9	-	21.6	-	-	-	-	-
Fertilizer sources								
S ₁ (NF)	34.8	35.4	485.2	486.1	118	121	246.0	248.4
S ₂ (WSF)	34.7	35.2	488.6	488.3	119	121	247.4	248.6
F test	NS	NS	NS	NS	NS	NS	NS	NS
C.D at 5%	-	-	-	-	-	-	-	-
Combined treatments								
Furrow irrigation								
T ₁ 80% Rec. dose NF	29.6	32.2	444.6	462.6	98	106	222.6	227.2
T ₂ 80% Rec. dose WSF	30.7	31.2	460.2	473.2	105	111	229.2	234.8
T ₃ 100% Rec. dose NF	34.9	36.6	490.2	480.8	116	118	239.6	245.0
T ₄ 100% Rec. dose WSF	33.2	35.3	473.0	484.6	115	117	242.8	241.8
Drip irrigation								
T ₅ 80% Rec. dose NF	34.2	33.3	479.2	481.8	117	120	246.4	248.8
T ₆ 80% Rec. dose WSF	34.3	34.8	478.4	481.3	114	119	241.2	248.5
T ₇ 100% Rec. dose NF	35.7	36.2	505.2	491.7	126	125	252.0	257.2
T ₈ 100% Rec. dose WSF	34.8	36.1	491.6	495.2	124	124	255.4	251.5
Fertigation								
T ₉ 80% Rec. dose NF	36.8	36.8	486.2	494.5	124	125	256.6	253.8
T ₁₀ 80% Rec. dose WSF	36.2	36.7	496.0	492.2	126	126	255.2	255.6
T ₁₁ 100% Rec. dose NF	37.4	37.2	505.6	504.7	130	130	258.8	258.3
T ₁₂ 100% Rec. dose WSF	38.8	37.5	532.4	503.4	128	131	260.4	259.7
F test	NS	NS	NS	NS	NS	NS	NS	NS
C.D. at 5%	-	-	-	-	-	-	-	-

Rec. Dose=150:75:50kg N:P₂O₅:K₂O/ha
DAS = Days after sowing

* = Significant
NS = Non-significant

NF = Normal fertilizer
WSF = Water soluble fertilizer

Contd.

Table-4.23 (Contd.) Yield attributes in maize as influenced by method of irrigation levels and sources of fertilizer during 1994 and 1996

Treatments	Cob length(cm)		Cob girth cm)		Shelling(%)		Prolificity (%)	
	1994	1996	1994	1996	1994	1996	1994	1996
Main treatments								
Irrigation methods								
I ₁ Furrow	17.63	18.54	15.32	15.78	73.98	72.99	4.96	5.52
I ₂ Drip	18.50	19.88	16.20	16.65	76.35	74.76	6.21	5.96
I ₃ Fertigation	19.20	20.35	16.77	17.00	78.18	76.30	6.65	6.89
F test	NS	*	*	*	NS	NS	*	*
C.D at 5%	-	1.43	1.20	0.93	-	-	0.99	0.73
Fertilizer levels								
L ₁ 80% Rec. dose	17.93	18.78	15.68	16.14	75.06	74.31	5.70	6.00
L ₂ 100% Rec. dose	18.95	20.40	16.51	16.81	77.29	74.92	6.17	6.25
F test	NS	*	NS	NS	NS	NS	NS	NS
C.D at 5%	-	0.70	-	-	-	-	-	-
Fertilizer sources								
S ₁ (NF)	18.43	19.61	16.14	16.20	76.37	74.69	5.87	6.08
S ₂ (WSF)	18.45	19.57	16.05	16.75	75.97	74.55	6.01	6.16
F test	NS	NS	NS	NS	NS	NS	NS	NS
C.D at 5%	-	-	-	-	-	-	-	-
Combined treatments								
Furrow irrigation								
T ₁ 80% Rec. dose NF	17.51	17.35	14.26	15.24	73.08	72.53	5.15	4.86
T ₂ 80% Rec. dose WSF	16.28	17.86	14.87	15.73	72.18	71.61	4.50	5.79
T ₃ 100% Rec. dose NF	18.44	19.85	16.13	14.93	75.71	73.84	4.36	6.09
T ₄ 100% Rec. dose WSF	18.29	19.10	16.02	17.22	74.95	73.19	5.83	5.35
Drip irrigation								
T ₅ 80% Rec. dose NF	17.22	19.36	15.80	15.98	75.63	74.17	5.90	5.84
T ₆ 80% Rec. dose WSF	18.40	18.72	15.57	16.60	75.28	75.35	5.75	5.71
T ₇ 100% Rec. dose NF	19.26	20.36	16.81	16.78	76.67	74.85	6.72	6.11
T ₈ 100% Rec. dose WSF	19.11	21.08	16.61	17.24	77.82	74.69	6.47	6.18
Fertigation								
T ₉ 80% Rec. dose NF	18.97	19.56	17.02	16.74	76.96	75.37	6.66	6.77
T ₁₀ 80% Rec. dose WSF	19.21	19.83	16.55	16.53	77.24	76.84	6.27	7.03
T ₁₁ 100% Rec. dose NF	19.20	21.16	16.84	17.53	80.16	77.38	6.44	6.83
T ₁₂ 100% Rec. dose WSF	19.42	20.85	16.67	17.20	78.36	75.60	7.23	6.93
F test	NS	NS	NS	NS	NS	NS	NS	NS
C.D. at 5%	-	-	-	-	-	-	-	-

Rec. Dose=150:75:50kg N:P₂O₅:K₂O/ha
DAS = Days after sowing

* = Significant
NS = Non-significant

NF = Normal fertilizer
WSF = Water soluble fertilizer

4.6 Growth characters in sunflower

4.6.1 Plant height of sunflower

Plant height recorded at 30, 60 DAS at harvest as influenced by methods of irrigation, levels and sources of fertilizer is presented in Table-4.24.

Plant height differed significantly due to irrigation methods only in 1997 at 30 DAS and both the years 1995 and 1997 at 60 DAS. It was the highest (42.6 cm) with fertigation at 30 DAS in 1997, 159.7 cm and 146.1 cm in 1995 and 1997 respectively at 60 DAS and significantly superior to 37.4 cm, 146.4 cm and 130.2 cm plant height observed with furrow method respectively. The values 41.5 cm, 142.4 cm and 173.8 cm for plant height observed under drip irrigation at the same stages as above were also significantly superior to furrow method but on par with fertigation. Though fertigation maintained increased plant height even at harvest, it was not significant over drip or furrow treatments.

Plant height did not vary significantly due to fertilizer levels except at 60 DAS in 1995 wherein full dose (100%) fertilizer registered 156.2 cm plant height as against 152.3 cm with 80% dose.

Both fertilizer sources as NF or WSF and interaction effect between various treatment combination were non-significant in influencing plant height at different growth stages.

4.6.2 Leaf area in sunflower

Data on leaf area recorded at 30 and 60 DAS as influenced by different treatments under study are presented here (Table-4.25).

Table-4.24: Plant height in sunflower as influenced by methods of irrigation levels and sources of fertilizer during 1995 and 1997

Treatments	Plant height (cm)					
	30 DAS		60 DAS		90 DAS	
	1995	1997	1995	1997	1995	1997
Main treatments						
Irrigation methods						
I ₁ Furrow	38.6	37.4	146.9	130.2	176.6	167.4
I ₂ Drip	42.9	41.5	156.2	142.4	185.2	173.8
I ₃ Fertigation	45.7	42.6	159.7	146.1	184.8	175.7
F test	NS	*	*	*	NS	NS
C.D at 5%	-	3.31	8.10	10.2	-	-
Fertilizer levels						
L ₁ 80% Rec. dose	41.6	39.7	152.3	137.2	180.1	170.2
L ₂ 100% Rec. dose	43.3	41.3	156.2	141.9	183.0	174.4
F test	NS	NS	NS	NS	NS	NS
C.D at 5%	-	-	-	-	-	-
Fertilizer sources						
S ₁ NF	42.4	40.2	154.4	139.8	181.0	173.2
S ₂ WSF	42.5	40.8	154.1	139.4	182.1	171.5
F test	NS	NS	NS	NS	NS	NS
C.D at 5%	-	-	-	-	-	-
Combined treatments						
Furrow irrigation						
T ₁ 80% Rec. dose NF	38.2	36.2	142.9	125.5	173.5	162.3
T ₂ 80% Rec. dose WSF	37.4	37.6	145.5	128.6	184.7	165.8
T ₃ 100% Rec. dose NF	39.6	38.1	152.8	133.7	178.2	172.2
T ₄ 100% Rec. dose WSF	39.2	37.7	146.4	133.2	170.0	169.3
Drip irrigation						
T ₅ 80% Rec. dose NF	41.5	41.5	152.6	138.6	177.5	170.9
T ₆ 80% Rec. dose WSF	42.2	39.2	155.7	141.7	178.2	168.3
T ₇ 100% Rec. dose NF	44.1	41.8	158.2	146.5	187.2	178.6
T ₈ 100% Rec. dose WSF	43.9	43.5	158.3	142.8	189.9	177.4
Fertigation						
T ₉ 80% Rec. dose NF	44.7	41.2	160.7	145.8	183.6	180.5
T ₁₀ 80% Rec. dose WSF	45.8	42.5	156.5	143.2	183.0	173.6
T ₁₁ 100% Rec. dose NF	46.0	42.5	159.2	148.7	186.2	174.2
T ₁₂ 100% Rec. dose WSF	46.3	44.2	162.4	146.7	186.6	174.5
F test	NS	NS	NS	NS	NS	NS
C.D. at 5%	-	-	-	-	-	-

Rec. Dose=63:75:63 kg N:P₂O₅:K₂O/ha
DAS = Days after sowing

* = Significant
NS = Non-significant

NF = Normal fertilizer
WSF = Water soluble fertilizer

Table-4.25: Leaf area in sunflower as influenced by methods of irrigation level and sources of fertilizer during 1995 and 1997

Treatments	Leaf area (cm ² /plant)			
	30 DAS		60 DAS	
	1995	1997	1995	1997
Main treatments				
<u>Irrigation methods</u>				
I ₁ Furrow	470.2	443.2	2438.6	2327.3
I ₂ Drip	487.3	459.2	2486.1	2383.5
I ₃ Fertigation	496.2	462.3	2517.3	2411.3
F test	NS	*	*	*
C.D at 5%	-	10.8	58.5	63.5
<u>Fertilizer levels</u>				
L ₁ 80% Rec. dose	478.1	447.9	2439.9	2343.4
L ₂ 100% Rec. dose	491.0	461.9	2521.4	2404.7
F test	NS	*	*	NS
C.D at 5%	-	12.5	73.6	-
<u>Fertilizer sources</u>				
S ₁ NF	483.1	454.3	2470.3	2366.9
S ₂ WSF	486.0	455.5	2491.0	2381.2
F test	NS	NS	NS	NS
C.D at 5%	-	-	-	-
<u>Combined treatments</u>				
<u>Furrow irrigation</u>				
T ₁ 80% Rec. dose NF	465.2	440.1	2357.4	2327.3
T ₂ 80% Rec. dose WSF	462.2	433.2	2439.4	2260.2
T ₃ 100% Rec. dose NF	470.1	447.3	2504.2	2356.1
T ₄ 100% Rec. dose WSF	483.3	452.2	2453.3	2365.6
<u>Drip irrigation</u>				
T ₅ 80% Rec. dose NF	475.2	440.3	2406.5	2324.2
T ₆ 80% Rec. dose WSF	484.1	453.1	2457.6	2359.1
T ₇ 100% Rec. dose NF	501.7	468.2	2517.3	2435.6
T ₈ 100% Rec. dose WSF	488.2	475.2	2563.0	2415.1
<u>Fertigation</u>				
T ₉ 80% Rec. dose NF	488.3	464.6	2478.1	2374.3
T ₁₀ 80% Rec. dose WSF	493.8	456.3	2500.3	2415.2
T ₁₁ 100% Rec. dose NF	498.3	465.1	2558.6	2384.2
T ₁₂ 100% Rec. dose WSF	504.4	463.2	2532.2	2471.5
F test	NS	NS	NS	NS
C.D. at 5%	-	-	-	-

Rec. Dose=63:75:63 kg N:P₂O₅:K₂O/ha
DAS = Days after sowing

* = Significant
NS = Non-significant

NF = Normal fertilizer
WSF = Water soluble fertilizer

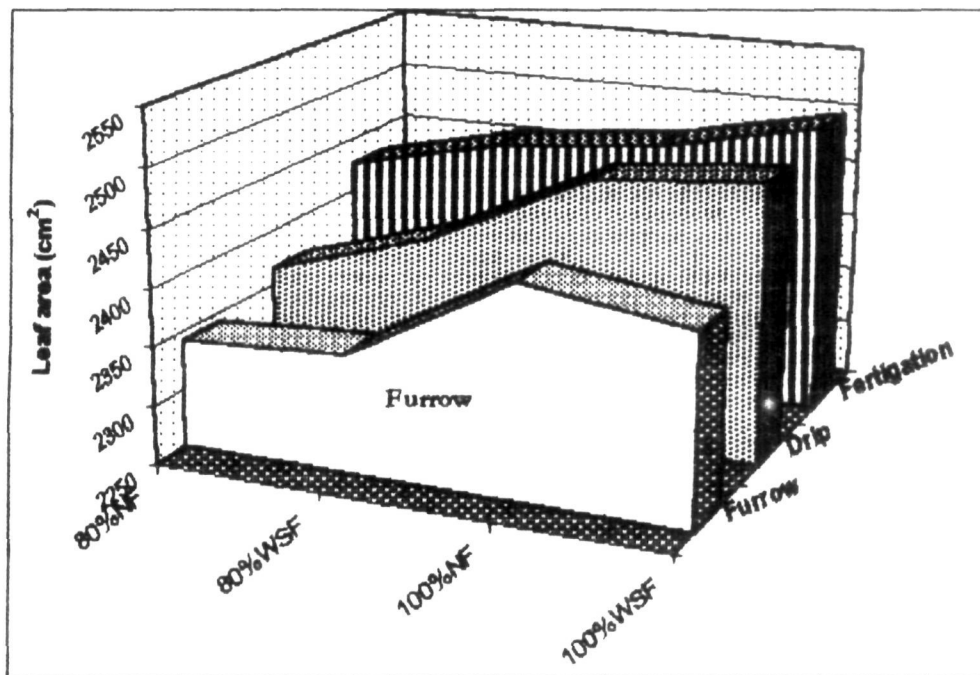

Fig . 4.10 : Leaf area in sunflower at 60DAS as influenced by fertigation, drip and furrow with levels and sources of fertilizer (mean of two years)

The leaf area responded significantly due to methods of irrigation. Highest leaf area (462.3 cm²) recorded at 30 DAS in 1997 and at 60 DAS both in 1995 and 1997 (2517.3 cm² and 2411.3 cm² respectively) was significantly superior to corresponding leaf area (443.2 cm², 2438.6 cm² and 2327.3 cm²) registered by furrow irrigated sunflower (Fig. 4.10). The leaf area recorded with drip irrigated sunflower (459 cm², 2486 cm² and 2383 cm² respectively) was on par with both fertigation and furrow treatment but significantly superior to the latter only at 30 DAS.

Fertilizer dose at 100% had higher leaf area of 447.9 cm² at 30 DAS (1997) and 2439.9 cm² at 60 DAS (1995) compared to 461.9 cm² (1997) and 2521.4 cm² (1995) at 80% level of fertilizers respectively.

Sources of WSF and NF did not bring significant changes in leaf area. Recommended level of 100% WSF (463 to 2532 cm²) or 80% NF applied to soil in furrow method (440 to 2327 cm² leaf area) statistically brought similar results in leaf area.

4.6.3 Number of leaves per plant in sunflower

Data on number of leaves per plant recorded at 60 DAS in sunflower as influenced by methods of irrigation levels and sources of fertilizer are presented in Table-4.26.

Number of leaves per plant differed in the first year 1995 being significantly higher (33.8 per plant) in fertigation than furrow (26.5 leaves per plant) but was on par with drip method (31.2 leaves per plant). Differences observed in terms of number of leaves 31.5, 29.2 and 25.8 per plant with fertigation, drip and furrow treatments respectively during 1997 were not statistically significant.

Increase in number of leaves from 29.6 in 80% dose to 31.5 by increased (100%) dose during 1995 and corresponding values 27.8 and 29.8 leaves per plant during 1997 were statistically identical.

Table-4.26: Number of leaves per plant in sunflower at 60 days after sowing as influenced by methods of irrigation levels and sources of fertilizer during 1995 and 1997

Treatments	No. of leaves/plant					
	1995			1997		
	80% Rec. dose (L ₁)	100% Rec. dose (L ₂)	Mean	80% Rec. dose (L ₁)	100% Rec. dose (L ₂)	Mean
<u>Main treatments</u>						
<u>Irrigation methods</u>						
I ₁ Furrow	25.6	27.3	26.5	26.0	25.5	25.8
I ₂ Drip	29.8	32.6	31.2	26.9	31.5	29.2
I ₃ Fertigation	33.3	34.3	33.8	30.5	32.4	31.5
Mean	29.6	31.5		27.8	29.8	
<u>Fertilizer sources</u>						
S ₁ NF	29.7	31.3	30.5	28.3	30.3	29.3
S ₂ WSF	29.5	31.5	30.5	27.3	29.3	28.3
Mean	29.6	31.5		27.8	29.8	
<u>Irrigation methods</u>						
	NF(S1)	WSF(S2)		NF(S1)	WSF(S2)	
I ₁ Furrow	26.8	26.1	26.5	25.4	26.2	25.8
I ₂ Drip	31.3	31.3	31.2	29.9	28.4	29.2
I ₃ Fertigation	33.6	33.9	33.8	32.6	30.3	31.5
Mean	30.5	30.5		29.3	28.3	
	I ₁	I ₂	I ₃	I ₁	I ₂	I ₃
L ₁ -100%R.D. S ₁ -NF	26.2	29.1	33.9	26.6	27.5	30.9
S ₂ -WSF	25.1	30.6	32.7	25.5	26.3	30.2
L ₂ -80%R.D. S ₁ -NF	27.5	33.1	33.4	24.2	32.4	34.4
S ₂ -WSF	27.2	32.1	35.2	26.9	30.6	30.5
	F-test	C.D at 5%		F-test	C.D at 5%	
I	*	4.7		NS	-	
L	NS	-		NS	-	
S	NS	-		NS	-	
I x L	NS	-		NS	-	
L x S	NS	-		NS	-	
I x S	NS	-		NS	-	
I x L x S	NS	-		NS	-	

Rec. Dose=63:75:63 kg N:P₂O₅:K₂O/ha
DAS = Days after sowing

* = Significant
NS = Non-significant

NF = Normal fertilizer
WSF = Water soluble fertilizer

Fertilizer sources did not bring differences in number of leaves per plant. Interaction effects were also absent.

4.6.4 Leaf area index (LAI) in sunflower

The LAI recorded at 30 and 60 DAS as influenced by various treatments under study is presented in Table-4.27.

At 30 DAS the LAI ranged from 0.26 to 0.28 in 1995 and 0.24 to 0.26 under the influence of various treatments under study but these were on par with each other.

However, at 60 DAS fertigation registered the highest LAI of 1.40 (1995) and 1.34 (1997) which was significantly superior to furrow method where the LAI was 1.35 and 1.29 respectively. Drip irrigation method with 1.38 and 1.32 LAI for 1995 and 1997 respectively was on par with both fertigation and furrow method.

Fertilizer levels or sources did not influence the LAI at both the stages. Similarly the variation in LAI from 0.24-0.28 at 30 DAS to 1.29-1.42 at 60 DAS due to interaction effect of combined treatments also was non-significant.

4.6.5 Total dry matter in sunflower

Total dry matter accumulation (DMA) recorded at 30, 60 DAS and at harvest as influenced by methods of irrigation, levels and sources of fertilizer is presented in Table 4.28.

The DMA was markedly influenced by methods of irrigation at all growth stages and years except at 30 DAS in 1997. Total dry matter accumulation was comparatively lower in the second year than in the first year. At 30 DAS, in 1995 fertigation had the highest DMA (7.38 g plant⁻¹) significantly superior to furrow (7.18 g plant⁻¹ DMA) but statistically identical to drip (7.29 g plant⁻¹ DMA) which in turn was on par with furrow treatment.

Table-4.27: Leaf Area Index (LAI) in sunflower as influenced by methods of irrigation, levels and sources of fertilizer during 1995 and 1997

Treatments	Leaf area Index			
	30 DAS		60 DAS	
	1995	1997	1995	1997
Main treatments				
<u>Irrigation methods</u>				
I ₁ Furrow	0.26	0.24	1.35	1.29
I ₂ Drip	0.27	0.25	1.38	1.32
I ₃ Fertigation	0.27	0.26	1.40	1.34
F test	NS	NS	*	*
C.D at 5%	-	-	0.03	0.04
<u>Fertilizer levels</u>				
L ₁ 80% Rec. dose	0.26	0.25	1.35	1.30
L ₂ 100% Rec. dose	0.27	0.26	1.40	1.33
F test	NS	NS	NS	NS
C.D at 5%	-	-	-	-
<u>Fertilizer sources</u>				
S ₁ NF	0.27	0.25	1.37	1.31
S ₂ WSF	0.27	0.25	1.38	1.32
F test	NS	NS	NS	NS
C.D at 5%	-	-	-	-
<u>Combined treatments</u>				
<u>Furrow irrigation</u>				
T ₁ 80% Rec. dose NF	0.26	0.24	1.31	1.29
T ₂ 80% Rec. dose WSF	0.26	0.24	1.35	1.25
T ₃ 100% Rec. dose NF	0.26	0.25	1.39	1.31
T ₄ 100% Rec. dose WSF	0.27	0.25	1.36	1.31
<u>Drip irrigation</u>				
T ₅ 80% Rec. dose NF	0.26	0.25	1.34	1.29
T ₆ 80% Rec. dose WSF	0.27	0.25	1.36	1.31
T ₇ 100% Rec. dose NF	0.28	0.26	1.40	1.35
T ₈ 100% Rec. dose WSF	0.27	0.26	1.42	1.34
<u>Fertigation</u>				
T ₉ 80% Rec. dose NF	0.27	0.26	1.38	1.32
T ₁₀ 80% Rec. dose WSF	0.27	0.25	1.39	1.34
T ₁₁ 100% Rec. dose NF	0.28	0.26	1.42	1.32
T ₁₂ 100% Rec. dose WSF	0.28	0.26	1.40	1.37
F test	NS	NS	NS	NS
C.D. at 5%	-	-	-	-

Rec. Dose=63:75:63 kg N:P₂O₅:K₂O/ha

DAS = Days after sowing

* = Significant

NS = Non-significant

NF = Normal fertilizer

WSF = Water soluble fertilizer

Table-4.28: Total dry matter accumulation in sunflower as influenced by methods of irrigation, levels and sources of fertilizer during 1995 and 1997

Treatments	Total dry matter accumulation(g/plant)					
	30 DAS		60 DAS		At Harvest	
	1995	1997	1995	1997	1995	1997
Main treatments						
Irrigation methods						
I ₁ Furrow	7.18	6.69	68.84	66.16	96.77	90.39
I ₂ Drip	7.29	6.81	80.84	76.41	109.13	101.18
I ₃ Fertigation	7.38	6.85	86.10	84.46	112.45	105.56
F test	*	NS	*	*	*	*
C.D at 5%	0.1	-	9.57	11.71	11.53	10.18
Fertilizer levels						
L ₁ 80% Rec. dose	7.22	6.71	75.95	73.45	103.41	95.85
L ₂ 100% Rec. dose	7.34	6.86	81.24	77.89	108.83	102.24
F test	NS	NS	NS	NS	NS	NS
C.D at 5%	-	-	-	-	-	-
Fertilizer sources						
S ₁ NF	7.30	6.81	78.89	75.64	105.82	98.99
S ₂ WSF	7.27	6.78	78.29	75.70	106.41	99.09
F test	NS	NS	NS	NS	NS	NS
C.D at 5%	-	-	-	-	-	-
Combined treatments						
Furrow irrigation						
T ₁ 80% Rec. dose NF	7.11	6.67	65.36	63.46	93.70	86.56
T ₂ 80% Rec. dose WSF	7.09	6.54	66.20	65.18	90.48	88.34
T ₃ 100% Rec. dose NF	7.34	6.78	70.14	68.63	103.17	95.23
T ₄ 100% Rec. dose WSF	7.18	6.76	73.65	67.38	99.90	91.43
Drip irrigation						
T ₅ 80% Rec. dose NF	7.25	6.72	79.10	74.73	106.83	98.46
T ₆ 80% Rec. dose WSF	7.20	6.68	76.90	70.65	108.08	95.30
T ₇ 100% Rec. dose NF	7.36	6.97	84.41	78.80	106.74	104.68
T ₈ 100% Rec. dose WSF	7.35	6.87	82.95	81.46	114.88	106.29
Fertigation						
T ₉ 80% Rec. dose NF	7.35	6.84	84.71	82.53	109.60	101.95
T ₁₀ 80% Rec. dose WSF	7.34	6.80	83.42	84.18	111.92	104.47
T ₁₁ 100% Rec. dose NF	7.38	6.87	89.64	85.70	114.91	107.09
T ₁₂ 100% Rec. dose WSF	7.45	6.90	86.62	85.36	113.37	107.73
F test	NS	NS	NS	NS	NS	NS
C.D. at 5%	-	-	-	-	-	-

Rec. Dose=63:75:63 kg N:P₂O₅:K₂O/ha
DAS = Days after sowing

* = Significant
NS = Non-significant

NF = Normal fertilizer
WSF = Water soluble fertilizer

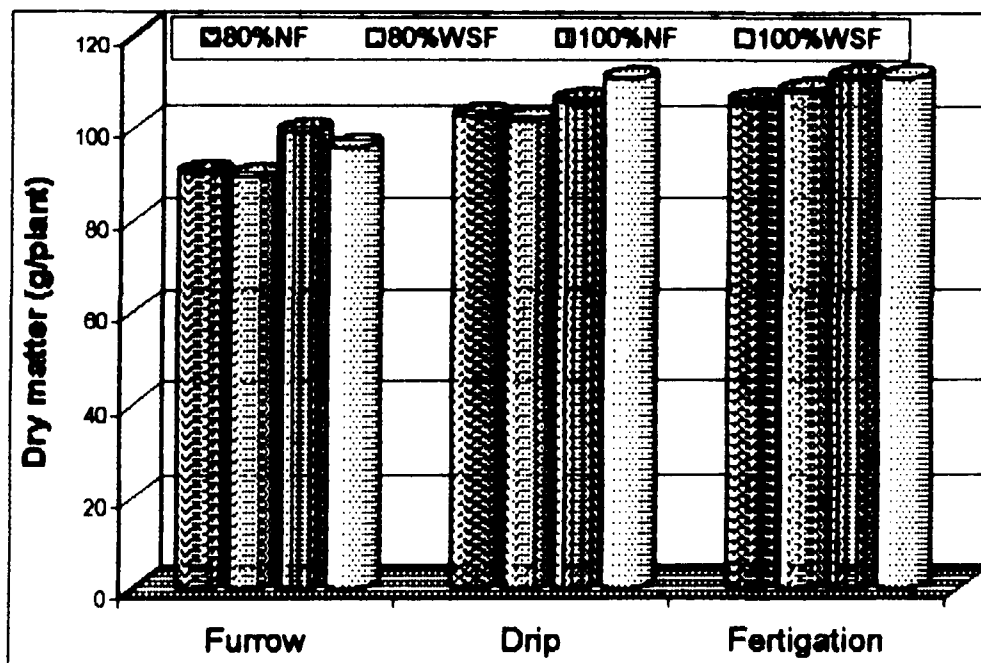

Fig. 4.11 : Dry matter in sunflower at harvest as influenced by fertigation, drip and furrow with levels and sources of fertilizer (mean of two years)

Maximum DMA of 84.46 g-112.45 g plant⁻¹ recorded with fertigated sunflower from 60 DAS to harvest in both the years was significant as compared to DMA (66.16 g to 96.8 g plant⁻¹) obtained under furrow method but was on par to drip irrigated sunflower where the DMA was to the tune of 76.41 g to 109.13 g plant⁻¹(Fig. 4.11).

Fertilizer levels of 80% and 100% recommended did not change the DMA of sunflower. The DMA increased with crop growth from about 7.0 g at 30 DAS to around 95 to 108 g at harvest.

Likewise, the slightest variation in DMA due to fertilizer sources as WSF and NF was statistically equal. Again the differences in DMA from 6.54 g, to 7.45 g at 30 DAS during both the years, 63.46 g to 89.64 g at 60 DAS and 86.56 g to 114.91g harvest was also not significant.

4.6.6. Dry matter distribution in sunflower

Data on dry matter distribution (g plant⁻¹) into stem, leaf and head recorded at 30, 60 DAS and at harvest as influenced by methods of irrigation, levels and sources of fertilizer are presented in 4.29.

Dry matter distribution at 30 DAS

The leaf as well as stem dry matter was significantly improved from 3.84 g and 3.12 g respectively in furrow irrigation to 3.96 g and 3.22g. by employing fertigation during the years 1995 and 1997. However drip irrigated sunflower recorded on par values (3.93 g and 3.17 g plant⁻¹) with fertigation treatment.

Table-4.29: Dry matter distribution in Sunflower as influenced by methods of irrigation, levels and sources of fertilizer during 1995 and 1997

Treatments	Dry matter distribution (g/plant)							
	30 DAS				60 DAS			
	Stem		Leaf		Stem		Leaf	
	1995	1997	1995	1997	1995	1997	1995	1997
Main treatments								
Irrigation methods								
I ₁ Furrow	3.84	3.57	3.34	3.12	36.18	35.68	18.35	16.11
I ₂ Drip	3.93	3.63	3.36	3.17	40.82	38.19	23.27	22.24
I ₃ Fertigation	3.96	3.64	3.42	3.22	42.26	42.70	26.51	24.37
F test	*	NS	NS	*	*	*	*	*
C.D at 5%	0.08	-	-	0.08	4.46	3.64	5.79	5.65
Fertilizer levels								
L ₁ 80% Rec. dose	3.86	3.58	3.36	3.13	39.17	38.04	21.76	20.21
L ₂ 100% Rec. dose	3.95	3.65	3.39	3.21	40.33	39.67	23.67	21.60
F test	*	NS	NS	NS	NS	NS	NS	NS
C.D at 5%	0.06	-	-	-	-	-	-	-
Fertilizer sources								
S ₁ (NF)	3.92	3.60	3.38	3.19	40.32	38.99	22.73	21.36
S ₂ (WSF)	3.90	3.62	3.37	3.15	39.18	38.72	24.10	20.46
F test	NS	NS	NS	NS	NS	NS	NS	NS
C.D at 5%	-	-	-	-	-	-	-	-
Combined treatments								
Furrow irrigation								
T ₁ 80% Rec. dose NF	3.75	3.50	3.36	3.14	34.77	36.05	17.92	14.66
T ₂ 80% Rec. dose WSF	3.79	3.61	3.31	2.97	36.05	35.27	15.97	16.05
T ₃ 100% Rec. dose NF	4.00	3.56	3.34	3.23	37.26	36.14	18.43	16.41
T ₄ 100% Rec. dose WSF	3.82	3.61	3.36	3.15	36.64	35.28	21.08	17.33
Drip irrigation								
T ₅ 80% Rec. dose NF	3.89	3.59	3.36	3.13	40.98	37.76	23.00	21.71
T ₆ 80% Rec. dose WSF	3.90	3.53	3.30	3.15	38.77	35.66	21.86	20.84
T ₇ 100% Rec. dose NF	3.95	3.75	3.41	3.19	42.32	38.14	24.05	27.57
T ₈ 100% Rec. dose WSF	3.98	3.65	3.37	3.22	41.21	41.20	24.18	18.84
Fertigation								
T ₉ 80% Rec. dose NF	3.95	3.61	3.39	3.23	42.56	41.26	25.72	23.65
T ₁₀ 80% Rec. dose WSF	3.92	3.63	3.42	3.17	41.92	42.25	26.06	24.36
T ₁₁ 100% Rec. dose NF	3.96	6.62	3.42	3.25	44.05	44.62	27.23	24.13
T ₁₂ 100% Rec. dose WSF	4.00	3.70	3.45	3.23	40.52	42.62	27.03	25.34
F test	NS	NS	NS	NS	NS	NS	NS	NS
C.D. at 5%	-	-	-	-	-	-	-	-

Rec. Dose=63:75:63 kg N:P₂O₅:K₂O/ha
DAS = Days after sowing

* = Significant
NS = Non-significant

NF = Normal fertilizer
WSF = Water soluble fertilizer

Contd.

Table-4.29: (Contd.) Dry matter distribution in sunflower as influenced by methods of irrigation, levels and sources of fertilizer during 1995 and 1997

Treatments	Dry matter distribution (g/plant)							
	60 DAS				At Harvest			
	Head		Stem		Leaf		Head	
	1995	1997	1995	1997	1995	1997	1995	1997
Main treatments								
Irrigation methods								
I ₁ Furrow	14.31	14.45	33.87	30.16	15.78	15.52	47.24	44.71
I ₂ Drip	16.58	15.98	36.54	34.65	18.89	16.75	53.71	49.85
I ₃ Fertigation	17.43	16.94	37.89	35.71	18.37	17.21	56.19	52.64
F test	*	*	*	*	*	NS	*	*
C.D at 5%	2.25	1.27	2.90	3.89	2.13	-	6.10	5.38
Fertilizer levels								
L ₁ 80% Rec. dose	15.64	14.91	34.66	32.13	17.22	16.27	51.67	47.50
L ₂ 100% Rec. dose	16.57	16.67	37.55	34.89	18.14	16.72	53.09	50.63
F test	*	NS	NS	NS	NS	NS	NS	NS
C.D at 5%	0.87	-	-	-	-	-	-	-
Fertilizer sources								
S ₁ NF	15.99	15.56	36.45	33.68	18.44	16.91	51.18	48.45
S ₂ WSF	16.23	16.01	35.76	33.33	16.92	16.08	53.58	49.68
F test	NS	NS	NS	NS	NS	NS	NS	NS
C.D at 5%	-	-	-	-	-	-	-	-
Combined treatments								
Furrow irrigation								
T ₁ 80% Rec. dose NF	12.97	12.75	33.76	28.85	16.78	16.05	43.16	41.65
T ₂ 80% Rec. dose WSF	14.88	13.86	31.00	30.16	14.56	14.14	45.25	44.04
T ₃ 100% Rec. dose NF	14.15	16.08	36.14	32.24	16.02	15.84	51.01	47.15
T ₄ 100% Rec. dose WSF	15.24	15.10	34.60	29.38	15.76	16.05	49.54	46.00
Drip irrigation								
T ₅ 80% Rec. dose NF	16.25	15.26	36.56	33.15	18.36	17.17	53.24	48.44
T ₆ 80% Rec. dose WSF	15.97	14.15	33.26	32.24	16.97	16.15	56.84	46.88
T ₇ 100% Rec. dose NF	17.34	16.42	37.26	36.37	20.16	17.24	49.32	51.07
T ₈ 100% Rec. dose WSF	16.76	18.09	39.08	36.84	20.07	16.44	55.43	53.01
Fertigation								
T ₉ 80% Rec. dose NF	17.36	15.89	36.75	35.25	18.55	16.84	54.36	49.86
T ₁₀ 80% Rec. dose WSF	16.44	17.57	36.60	33.10	18.10	17.25	57.16	54.12
T ₁₁ 100% Rec. dose NF	17.85	17.00	38.21	36.24	20.75	18.32	56.00	52.53
T ₁₂ 100% Rec. dose WSF	18.07	17.32	40.00	38.25	16.08	16.43	57.24	54.05
F test	NS	NS	NS	NS	NS	NS	NS	NS
C.D. at 5%	-	-	-	-	-	-	-	-

Rec. Dose=63:75:63 kg N:P₂O₅:K₂O/ha
DAS = Days after sowing

* = Significant
NS = Non-significant

NF = Normal fertilizer
WSF = Water soluble fertilizer

Significantly superior stem dry weight (3.95 g) was observed with 100% recommended dose than with 80% recommended dose (3.86 g) in 1995. Except this, increased leaf dry weight and stem dry weight in both 1995 and 1997 due to full fertilizer dose was not statistically higher than the values recorded for 80% dose.

Differences in dry matter production into leaf or stem were not found significant due to either sources of fertilizer or interaction effects of combined treatments.

Dry matter distribution at 60 DAS

The data presented in Table-4.29 indicated that dry matter distribution improved considerably on account of combining fertilizer through irrigation over traditional furrow method.

Significantly higher stem dry matter of 42.26 g (1995) and 42.70 g (1997) was registered with fertigation than with furrow which produced 36.18 g in 1995 and both drip (38.19 g) and furrow (3568 g) in 1997. Similarly maximum leaf dry weight (26.51 g and 24.37 g in 1995 and 1997 respectively) was associated with fertigation followed by drip (23.27 g and 22.24 g respectively). Lowest values for leaf dry weight (18.35 g and 16.11 g respectively) were recorded under furrow method.

Fertigation significantly enhanced head dry weight at 60 DAS from 14.31 g in furrow to 17.43 g plant⁻¹ during 1995. Head dry matter (16.58 g) recorded with drip was on par with fertigation but superior to furrow method. The corresponding values of 14.45 g, 16.94 g and 15.98 g in 1997 followed the same trend as in 1995.

Fertilizer level at 100% dose steadily produced higher stem, leaf and head dry matter at 60 DAS during both the years of observation. However, significant increase was noticed only in

1995 wherein head dry weight of 16.57 g plant⁻¹ with the 100% dose was superior over 15.64 g recorded with 80% dose.

Response of sunflower in terms of dry matter partition into leaf, stem and head due to sources of fertilizer was not significant. Dry matter differences in stem, leaf and head due to treatment combinations were all non-significant.

Dry matter distribution at harvest

Dry matter differences were significant due to direct effect of irrigation methods barring leaf dry weight in 1997. The highest stem dry weight of 37.89 g and 35.71 g in 1995 and 1997 respectively recorded with fertigation was significantly superior to furrow irrigated sunflower where the stem dry matter was 33.87 g and 30.16 g respectively. Drip treatment with stem dry weight of 36.54 g and 34.65 g respectively was on par to fertigation but superior to furrow method in 1997 only.

Leaf dry weight of 18.37 g, 18.89 g and 15.78 g in 1995 registered by fertigation, drip and furrow followed similar trend as that of stem dry weight in 1995.

The head dry weight in both the years responded significantly to fertigation which produced the highest head dry weight of 56.19 g and 52.64 g in 1995 and 1997 respectively as compared to 47.24 g and 44.71 g recorded with furrow method. The values for the drip method 53.71 g and 49.85 g were on par with fertigation but superior to furrow only in 1995.

Stem, leaf and head dry matter were not influenced by fertilizer levels. Similarly, the sources of WSF or NF had no influence on dry matter partition. Further, although fertigation combinations recorded maximum values for stem (33.10 g – 40.00 g), leaf (16.43 g – 20.75 g) and head (49.86 g – 57.24 g) dry matter compared to drip (32.24 g to 39.88 g, 16.15 g to 20.16 g and

46.88 g to 56.89 g correspondingly) and furrow (28.85 g to 36.14 g, 14.14 g to 16.78 g and 41.65 g to 51.07 g respectively) the response was not significant.

4.6.7 Days taken for 50% flowering in sunflower

Flowering in sunflower was influenced due to treatments imposed only in 1997 (Table-4.30). Fertigation significantly advanced days taken for 50% flowering by four days as compared to 59 days when the crop was furrow irrigated. Flowering under drip irrigation (57 days) was statistically equal to both fertigation and furrow method.

Response in terms of flowering in sunflower was not significant due to levels or sources of fertilizer and even their interaction within themselves.

4.6.8 Stem diameter at harvest

Data on stem diameter (cm) at harvest as influenced by various treatments under study are presented in Table-4.30.

Stem diameter increased from 25.5 cm in furrow to 28.2 cm in drip and 29.6 in fertigation wherein the latter two treatments were significantly superior to furrow in 1995. However, improvement in stem diameter in 1997 was not significant.

Stem diameter of 28.7 cm in 1995 and 27.9 cm in 1997 recorded with 100% dose was not significantly superior to 80% recommended dose which registered 26.8 cm and 26.3 cm respectively.

Similarly diameter of stem did not respond significantly due to fertilizer sources or interaction among treatment factors and their levels.

Table-4.30: Days taken for 50% flowering and stem diameter at harvest in sunflower as influenced by methods of irrigation, levels and sources of fertilizer during 1995 and 1997

Treatments	Days taken for 50% flowering		Stem dia meter at harvest (mm)	
	1995	1997	1995	1997
Main treatments				
<u>Irrigation methods</u>				
I ₁ Furrow	57.92	59.25	25.50	25.90
I ₂ Drip	56.18	56.92	28.20	27.40
I ₃ Fertigation	56.42	55.08	29.60	28.00
F test	NS	*	*	NS
C.D at 5%	-	2.92	2.67	-
<u>Fertilizer levels</u>				
L ₁ 80% Rec. dose	56.72	57.83	26.80	26.30
L ₂ 100% Rec. dose	56.94	56.33	26.70	27.90
F test	NS	NS	NS	NS
C.D at 5%	-	-	-	-
<u>Fertilizer sources</u>				
S ₁ NF	56.94	57.17	27.10	26.10
S ₂ WSF	56.72	57.00	28.40	28.10
F test	NS	NS	NS	*
C.D at 5%	-	-	-	1.9
<u>Combined treatments</u>				
<u>Furrow irrigation</u>				
T ₁ 80% Rec. dose NF	56.67	59.33	23.80	24.50
T ₂ 80% Rec. dose WSF	58.00	61.67	24.60	23.40
T ₃ 100% Rec. dose NF	56.67	58.67	27.20	26.50
T ₄ 100% Rec. dose WSF	60.33	57.33	26.40	29.20
<u>Drip irrigation</u>				
T ₅ 80% Rec. dose NF	57.00	58.67	27.80	25.70
T ₆ 80% Rec. dose WSF	56.00	56.67	28.60	29.80
T ₇ 100% Rec. dose NF	57.33	55.00	26.00	26.80
T ₈ 100% Rec. dose WSF	54.33	57.33	30.40	27.30
<u>Fertigation</u>				
T ₉ 80% Rec. dose NF	57.33	56.00	28.50	26.50
T ₁₀ 80% Rec. dose WSF	55.33	54.67	27.80	28.10
T ₁₁ 100% Rec. dose NF	56.67	55.83	29.50	26.40
T ₁₂ 100% Rec. dose WSF	56.33	54.33	32.60	31.00
F test	NS	NS	NS	NS
C.D. at 5%	-	-	-	-

Rec. Dose=63:75:63 kg N:P₂O₅:K₂O/ha
DAS = Days after sowing

* = Significant
NS = Non-significant

NF = Normal fertilizer
WSF = Water soluble fertilizer

4.7 Yield and its components in sunflower

4.7.1 Seed and stalk yield of sunflower (kg ha^{-1})

Data on seed yield and stalk yield of sunflower in kg ha^{-1} as influenced by methods of irrigation, levels and sources of fertilizer are presented in Table-4.31.

Fertigation had significant influence on seed yield of sunflower in both the years. The seed yield was enhanced from $1355.8 \text{ kg ha}^{-1}$ in furrow method to $1621.5 \text{ kg ha}^{-1}$ by fertigation. Drip irrigation recorded $1518.7 \text{ kg ha}^{-1}$ seed yield which was significantly superior over furrow but was on par with fertigation during 1995. The corresponding figures of 1247.7 kg , 1460.5 kg and $1375.8 \text{ kg ha}^{-1}$ in 1997 also showed superiority of fertigation over mere furrow irrigation. However, the drip treatment was on par with both fertigation and furrow method (Fig. 4.12).

Fertilizer levels did not evince significant response in terms of sunflower seed yield ($1549.8 \text{ kg ha}^{-1}$, and $1402.8 \text{ kg ha}^{-1}$ with 100% dose and $1447.6 \text{ kg ha}^{-1}$ and $1319.9 \text{ kg ha}^{-1}$ with 80% dose during 1995 and 1997 respectively).

Influence of fertilizer sources on seed was not significant. Similarly yield differences from $1177.5 \text{ kg ha}^{-1}$ to $1400.5 \text{ kg ha}^{-1}$ in furrow, $1296.5 \text{ kg ha}^{-1}$ to $1605.6 \text{ kg ha}^{-1}$ in drip and $1405.2 \text{ kg ha}^{-1}$ to $1700.7 \text{ kg ha}^{-1}$ in fertigation were not significant during both the years.

Stalk yield

Stalk yield differed significantly due to irrigation methods in both the years 1995 and 1997 (Table-4.31). The treatment of fertigation gave the highest stalk yield (1710.4 and $1668.6 \text{ kg ha}^{-1}$) followed by drip (1657.8 and $1629.4 \text{ kg ha}^{-1}$). Furrow irrigation had significantly lower stalk yield of 1592.3 and $1550.7 \text{ kg ha}^{-1}$ in 1995 and 1997 respectively than fertigation.

Table-4.31: Seed and stalk yield in sunflower as influenced by methods of irrigation, levels and sources of fertilizer during 1995 and 1997

Treatments	Grain yield (kg/ha)				Stover yield (kg/ha)			
	1994		1996		1994		1996	
	80%RD (L ₁)	100%RD (L ₂)	Mean	80%RD (L ₁)	100%RD (L ₂)	Mean	80%RD (L ₁)	100%RD (L ₂)
<u>Main treatments</u>								
I Furrow	1295	1416	1356	1200	1296	1248	1554	1594
I ₂ Drip	1472	1566	1519	1324	1428	1376	1604	1668
I ₃ Fertigation	1576	1667	1622	1436	1485	1461	1685	1718
Mean	1448	1550	1320	1320	1403	1461	1614	1650
S ₁ NF	1458	1557	1507	1311	1392	1352	1607	1646
S ₂ WSF	1438	1543	1491	1329	1414	1371	1622	1680
Mean	1448	1550	1320	1320	1403	1461	1685	1660
	NF(S ₁)	WSF(S ₂)	NF(S ₁)	WSF(S ₂)	NF(S ₁)	WSF(S ₂)	NF(S ₁)	WSF(S ₂)
I ₁ Furrow	1382	1330	1356	1352	1243	1248	1605	1580
I ₂ Drip	1527	1511	1519	1373	1379	1376	1653	1662
I ₃ Fertigation	1614	1629	1622	1430	1491	1461	1679	1742
Mean	1507	1490	1352	1352	1371	1461	1646	1661
	I ₁	I ₂	I ₃	I ₁	I ₂	I ₃	I ₁	I ₂
L ₁ 100%RD	1331	1448	1594	1178	1351	1405	1593	1531
L ₂ 80%RD	1260	1495	1558	1222	1297	1468	1515	1484
	1432	1606	1634	1327	1394	1455	1617	1703
	1400	1526	1701	1265	1461	1514	1645	1688
	F-test *	C.D. at 5%	F-test *	C.D. at 5%	F-test *	C.D. at 5%	F-test *	C.D. at 5%
I	NS	156.2	NS	143.2	NS	79.6	NS	83.5
L	NS	-	NS	-	NS	-	*	41.5
S	NS	-	NS	-	NS	-	NS	-
I x L	NS	-	NS	-	NS	-	NS	-
L x S	NS	-	NS	-	NS	-	NS	-
I x S	NS	-	NS	-	NS	-	NS	-
I x L x S	NS	-	NS	-	NS	-	NS	-

Rec. Dose=63.75.63 kg N:P₂O₅:K₂O/ha DAS = Days after sowing * = Significant NS = Non-significant NF = Normal fertilizer WSF = Water soluble fertilizer

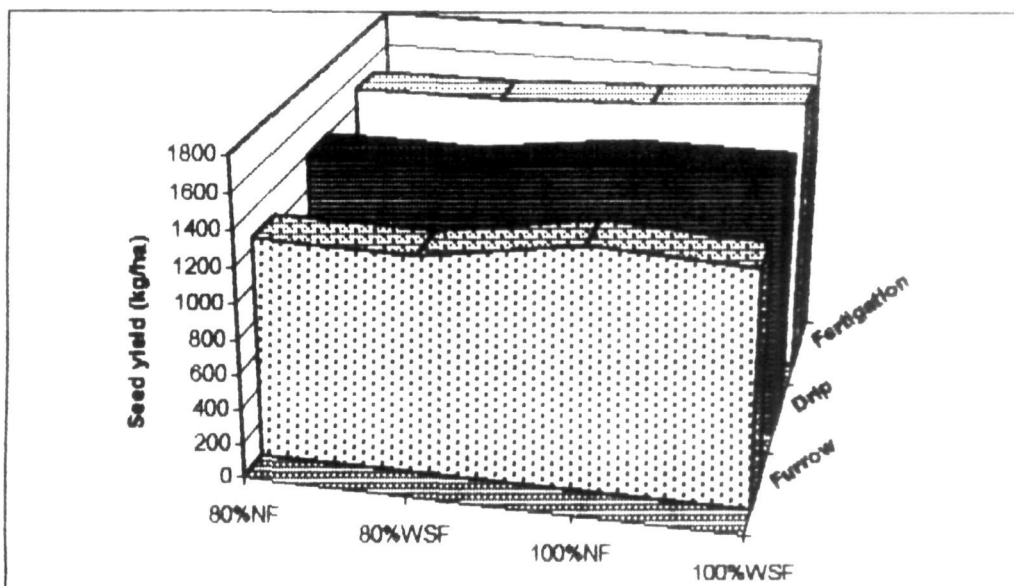

Fig. 4.12 Seed yield (kg/ha) in sunflower as influenced by fertigation, drip and furrow with levels and sources of fertilizer (mean of two years)

The recommended fertilizer dose (100%) had significantly higher stover yield only in 1997 (1636.5 kg ha⁻¹) compared to 80% level (1595 kg ha⁻¹).

Neither fertilizer sources nor the interaction effect between different treatments was found significant in influencing the stalk yield in sunflower.

4.7.2 Yield components in sunflower

Data on yield components in sunflower as influenced by methods of irrigation, sources and levels of fertilizer are presented in Table-4.32.

Yield attributes were considerably influenced by irrigation methods. The seed yield per plant (33.5g) and number of seeds per head (975) were significantly higher in the fertigation treatment in 1995 than furrow irrigated sunflower (26.6 g and 917 seeds head⁻¹ respectively). In 1997, only seed yield per plant (32.2 g) showed significant improvement due to fertigation over furrow treatment (25.21 g). Seed yield (30.1 g) recorded under drip method was also superior to furrow only in 1995.

Number of filled seeds (784 and 795 in the years 1995 and 1997 respectively) and filling per cent (80.5 and 79.4 % respectively) were significantly superior under fertigation than with furrow (687, 652, 73.8% and 74.7% respectively) treatment but were on par with drip method (742, 722, 77.4% and 77.6% respectively). Similarly, the test weight recorded with fertigation (4.24 and 4.16 g) during both the years 1995 and 1997 (Table-4.32) was significantly superior to furrow (3.79 g and 3.81 g) but was statistically equal to that obtained under drip (4.07 and 4.04 g).

The data on husk per cent in 1995, threshing per cent as well as head diameter (Table-4.32) also indicated the consistency of fertigation treatment in significantly improving these yield

Table-4.32: Yield attributes in sunflower as influenced by methods of irrigation levels and sources of fertilizer during 1995 and 1997

Treatments	Seed Yield (g/plant)		No. of seeds/head		No. of filled seeds/head		Filling (%)	
	1995	1997	1995	1997	1995	1997	1995	1997
<u>Main treatments</u>								
<u>Irrigation methods</u>								
I ₁ Furrow	26.61	25.21	917	873	678	652	73.8	74.7
I ₂ Drip	31.66	30.07	958	933	742	722	77.4	77.6
I ₃ Fertigation	33.53	32.24	975	940	784	745	80.5	79.4
F test	*	*	*	NS	*	*	*	*
C.D at 5%	3.54	5.02	43	-	56	71	4.4	3.2
<u>Fertilizer levels</u>								
L ₁ 80% Rec. dose	29.47	27.71	907	888	695	676	76.6	76.5
L ₂ 100% Rec. dose	31.73	30.64	993	942	774	737	77.9	78.0
F test	NS	*	*	NS	*	*	NS	*
C.D at 5%	-	2.64	31	-	47	32	-	0.8
<u>Fertilizer sources</u>								
S ₁ (NF)	30.84	28.88	950	904	731	698	76.8	77.5
S ₂ (WSF)	30.35	29.47	949	926	738	714	77.7	78.0
F test	NS	NS	NS	NS	NS	NS	NS	NS
C.D at 5%	-	-	-	-	-	-	-	-
<u>Combined treatments</u>								
<u>Furrow irrigation</u>								
T ₁ 80% Rec. dose NF	25.71	23.97	890	830	642	618	72.1	74.5
T ₂ 80% Rec. dose WSF	24.84	23.48	845	863	622	635	73.6	73.6
T ₃ 100% Rec. dose NF	29.04	27.05	933	930	703	704	75.4	75.7
T ₄ 100% Rec. dose WSF	26.85	25.68	1000	869	744	652	74.2	75.0
<u>Drip irrigation</u>								
T ₅ 80% Rec. dose NF	30.84	28.55	934	928	700	693	75.0	76.8
T ₆ 80% Rec. dose WSF	30.06	27.32	887	886	685	671	77.1	75.7
T ₇ 100% Rec. dose NF	33.00	31.28	1015	925	802	735	79.0	79.4
T ₈ 100% Rec. dose WSF	32.74	33.15	996	995	782	789	78.5	78.5
<u>Fertigation</u>								
T ₉ 80% Rec. dose NF	32.88	29.88	934	897	750	707	80.0	78.8
T ₁₀ 80% Rec. dose WSF	32.50	33.04	950	925	774	732	81.5	79.6
T ₁₁ 100% Rec. dose NF	33.60	32.56	998	918	791	734	79.3	80.0
T ₁₂ 100% Rec. dose WSF	35.14	33.58	1018	1020	823	808	81.2	79.2
F test	NS	NS	NS	NS	NS	NS	NS	NS
C.D. at 5%	-	-	-	-	-	-	-	-

Rec. Dose=63:75:63 kg N:P₂O₅:K₂O/ha
DAS = Days after sowing

* = Significant
NS = Non-significant

NF = Normal fertilizer
WSF = Water soluble fertilizer

Contd.

Table-4.32: (Contd.) Yield attributes in sunflower as influenced by methods of irrigation levels and sources of fertilizer during 1995 and 1997

Treatments	100 seed weight (g)		Husk %		Threshing %		Head diameter (cm)	
	1995	1997	1995	1997	1995	1997	1995	1997
Main treatments								
Irrigation methods								
I ₁ Furrow	3.79	3.81	32.53	32.53	56.40	56.01	12.6	12.7
I ₂ Drip	4.07	4.04	31.70	31.26	59.22	58.18	14.4	14.1
I ₃ Fertigation	4.24	4.16	31.00	31.75	59.88	62.56	15.2	14.8
F test	*	*	*	NS	*	*	*	*
C.D at 5%	0.22	0.26	1.12	-	2.33	4.78	1.3	1.2
Fertilizer levels								
L ₁ 80% Rec. dose	3.91	3.83	32.27	31.96	58.02	57.82	13.5	13.3
L ₂ 100% Rec. dose	4.15	4.12	31.11	31.74	58.98	60.02	14.6	14.4
F test	*	NS	NS	NS	NS	NS	NS	*
C.D at 5%	0.17	-	-	-	-	-	-	0.90
Fertilizer sources								
S ₁ (NF)	4.01	3.96	31.98	32.80	59.55	59.62	13.7	13.8
S ₂ (WSF)	4.05	4.05	31.51	30.89	57.45	58.22	14.4	13.9
F test	NS	NS	NS	*	*	NS	NS	NS
C.D at 5%	-	-	-	1.35	1.72	-	-	-
Combined treatments								
Furrow irrigation								
T ₁ 80% Rec. dose NF	3.70	3.50	33.94	34.75	59.57	57.55	12.0	11.3
T ₂ 80% Rec. dose WSF	3.61	3.64	31.15	30.57	54.90	53.31	11.9	12.0
T ₃ 100% Rec. dose NF	3.82	4.40	31.92	32.56	56.93	57.37	13.4	13.8
T ₄ 100% Rec. dose WSF	4.03	3.96	33.11	32.24	54.20	55.83	12.9	13.6
Drip irrigation								
T ₅ 80% Rec. dose NF	3.85	3.93	32.88	32.48	58.02	57.31	13.1	14.2
T ₆ 80% Rec. dose WSF	3.96	3.85	32.00	30.24	57.87	54.35	14.6	12.9
T ₇ 100% Rec. dose NF	4.30	4.11	31.37	32.55	61.91	59.55	14.2	14.5
T ₈ 100% Rec. dose WSF	4.17	4.27	30.56	29.77	59.07	61.30	15.5	14.8
Fertigation								
T ₉ 80% Rec. dose NF	4.18	3.98	32.21	31.99	60.68	63.34	14.5	14.6
T ₁₀ 80% Rec. dose WSF	4.19	4.10	32.06	31.71	57.06	61.05	14.9	14.9
T ₁₁ 100% Rec. dose NF	4.23	4.10	29.56	32.46	60.20	62.58	15.0	14.5
T ₁₂ 100% Rec. dose WSF	4.35	4.46	30.17	30.84	61.59	62.27	16.6	15.4
F test	NS	NS	NS	NS	NS	NS	NS	NS
C.D. at 5%	-	-	-	-	-	-	-	-

Rec. Dose=63:75:63 kg N:P₂O₅:K₂O/ha

* = Significant

NF = Normal fertilizer

attributes as compared to furrow method. At the same time, it was observed that the values for drip method for husk per cent, threshing per cent, and head dia meter were on par with fertigation but significantly superior to furrow method except the threshing per cent in 1997 (Table-4.32).

Between the fertilizer levels, the full dose (100%) recorded insignificantly higher values for most of the yield components. However, seed yield of 30.64 g plant⁻¹ in 1997, 993 number of seeds per head in 1995 recorded with 100% dose were significantly higher than 27.71 g and 907 seeds respectively registered by 80% dose. Similarly, number of filled seeds in both the years and filling per cent in 1997 also followed the same trend. Further, the recommended dose (100%) produced superior test weight (4.15 g) in 1995 and head diameter (14.4 cm) in 1997 only as compared to 3.91 g and 13.3 cm observed with 80% dose respectively.

Fertilizer sources of NF and WSP did not influence the yield attribute in sunflower like seed yield per plant. However reduced husk per cent (30.89%) by WSP was significant over NF in 1997 (32.80%). Similarly the threshing per cent was also significantly lower (57.45%) with WSP as compared to NF (59.55%) only in 1995.

The overall interaction effects between I x L, L x S, I x L or I x L x S were not statistically significant (Table-4.32).

4.8 Quality analysis

4.8.1 Oil content in sunflower

Data on oil content in sunflower as influenced by methods of irrigation, levels and sources of fertilizer are presented in Table-4.33.

Seed oil content of 43.8%, 44.6% and 47.8% registered by furrow, drip and fertigation respectively were at par with each other in 1995. Also, corresponding figures 42.6%, 44.6% and 45.0% represented same trend in 1997.

Table-4.33: Oil content and oil yield in sunflower as influenced by methods of irrigation, levels and sources of fertilizer during 1995 and 1997

Treatments	Oil content (%)		Oil yield (kg/ha)	
	1995	1997	1995	1997
Main treatments				
Irrigation methods				
I ₁ Furrow	43.8	42.6	593.50	532.21
I ₂ Drip	44.6	44.6	677.32	613.77
I ₃ Fertigation	47.8	45.0	734.17	657.19
F test	NS	NS	*	*
C.D at 5%	-	-	95.62	70.7
Fertilizer levels				
L ₁ 80% Rec. dose	44.7	43.5	640.23	574.70
L ₂ 100% Rec. dose	46.1	44.7	696.37	627.42
F test	NS	NS	*	*
C.D at 5%	-	-	30.40	52.28
Fertilizer sources				
S ₁ NF	45.7	44.4	670.49	600.27
S ₂ WSF	45.1	43.8	666.11	601.84
F test	NS	NS	NS	NS
C.D at 5%	-	-	-	-
Combined treatments				
Furrow irrigation				
T ₁ 80% Rec. dose NF	44.8	43.1	596.38	507.50
T ₂ 80% Rec. dose WSF	42.5	40.6	535.30	495.97
T ₃ 100% Rec. dose NF	43.6	44.3	625.50	587.67
T ₄ 100% Rec. dose WSF	44.4	42.5	621.83	537.70
Drip irrigation				
T ₅ 80% Rec. dose NF	45.3	45.0	657.70	608.00
T ₆ 80% Rec. dose WSF	43.0	44.3	643.03	574.33
T ₇ 100% Rec. dose NF	44.2	43.7	709.67	609.23
T ₈ 100% Rec. dose WSF	45.9	45.4	700.50	663.50
Fertigation				
T ₉ 80% Rec. dose NF	46.0	44.3	700.73	622.50
T ₁₀ 80% Rec. dose WSF	46.6	43.6	710.23	639.87
T ₁₁ 100% Rec. dose NF	50.3	45.9	739.97	666.70
T ₁₂ 100% Rec. dose WSF	48.2	46.2	785.70	699.70
F test	NS	NS	NS	NS
C.D. at 5%	-	-	-	-

Rec. Dose=63:75:63 kg N:P₂O₅:K₂O/ha
 63:75:63 = 63:75:63 kg N:P₂O₅:K₂O/ha

* = Significant
 NS = Not Significant

NF = Normal fertilizer
 WSF = Water Soluble Fertilizer

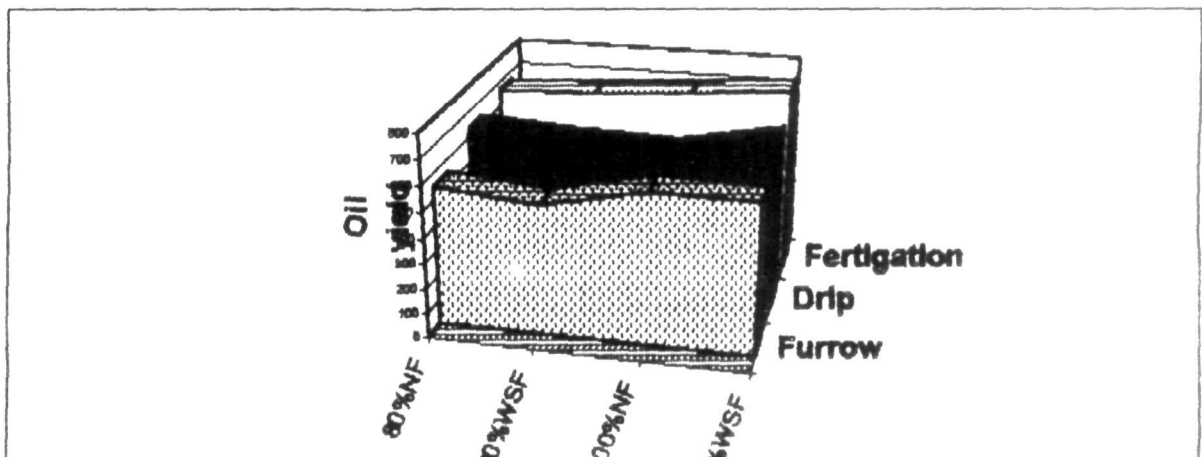
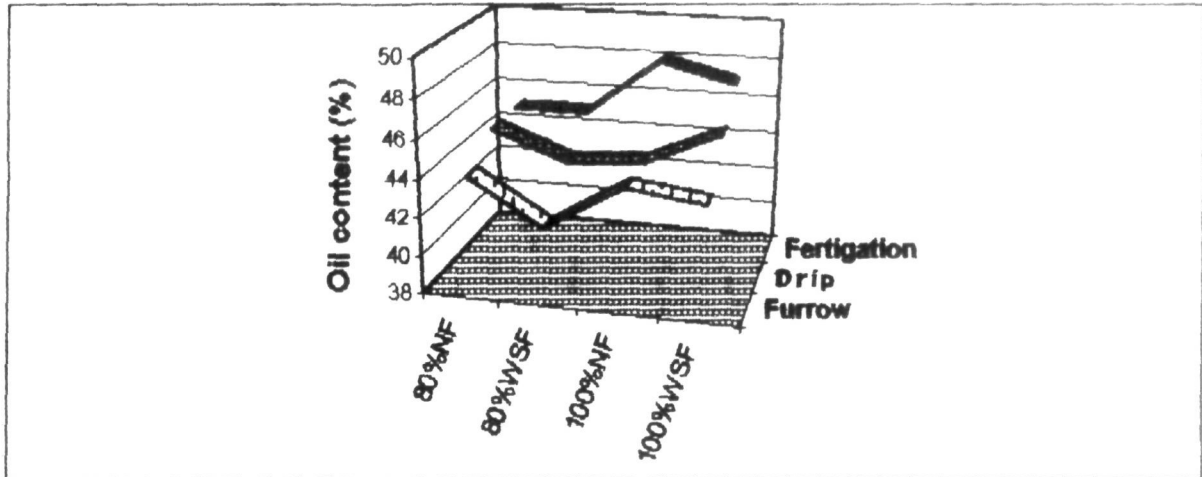

Fig. 4.13 : Oil content and oil yield (kg/ha) In sunflower as influenced by fertigation, drip and furrow with levels and sources of fertilizer (mean of two years)

Variations in seed oil content due to fertilizer levels or sources or interaction effect among combined treatments were not significant either in 1995 or 1997 although oil content varied between 42.5%-50.3% in 1995 and 40.6%-46.2% in 1997.

4.8.2 Oil yield in sunflower

Data on oil yield in sunflower as influenced by different treatments under study is presented in Table-4.33.

Oil yield under fertigation was in the order of 734.2 and 657.2 kg ha⁻¹ for 1995 and 1997 respectively and hence significantly superior to furrow method where corresponding oil yield was 593.5 and 532.2 kg ha⁻¹. Drip treatment produced 677.3 and 613.8 kg ha⁻¹ oil yield correspondingly and was on par with both fertigation and furrow method in 1995 but superior to furrow irrigation in 1997 (Fig. 4.13).

Recommended dose of fertilizer level (100%) had higher oil yield (696.4 and 627.4 kg ha⁻¹ significantly during both 1995 and 1997 as compared to the lower (80%) dose (640.2 and 574.7 kg ha⁻¹ respectively).

Significant variations in terms of oil yield were not observed because of fertilizer sources. Further, the highest oil yield of 785.7 kg and 699.7 kg ha⁻¹ in 1995 and 1997 respectively obtained with 100% dose WSF applied through fertigation as against the lowest oil yield of 535.3 kg and 496.0 kg ha⁻¹ respectively in 80% dose WSF applied in furrow method was also non-significant statistically.

4.9 Nutrient uptake studies

4.9.1 Nutrient content in capsicum, maize and sunflower

Data on N, P and K content in whole plant of capsicum, maize and sunflower determined at final harvest are presented in Table-4.34.

Nitrogen content in capsicum plant dry matter at harvest was 2.87% to 2.93% in 1994 and 2.86 to 2.94% in 1996. The P content ranged from 0.76% to 0.85% without much difference between the two years 1994 and 1996. The plants had K content to the tune of 4.42% to 4.63% over the two years of observation.

N, P and K content in maize was 1.42% to 1.52%, 0.25% to 0.29%, 1.28 to 1.37% respectively and values for 1996 were slightly higher than 1994.

Sunflower plants had 1.54% to 1.62% N, 0.24% to 0.29% and 1.02% to 1.08% K during both 1995 and 1997 under the influence of different treatments.

4.9.2 N, P and K uptake in capsicum

Data on N, P and K uptake in capsicum as influenced by methods of irrigation, levels and sources of fertilizer are furnished Table-4.35 and depicted in Fig. 4.14.

The N, P and K uptake was highest with fertigation in both years 1994 and 1996 (32.2 and 31.4 kg ha⁻¹, 9.2 and 8.8 kg ha⁻¹ and 50.5 and 48.7 kg ha⁻¹ respectively) followed by drip irrigation (28.7 and 29.5 kg ha⁻¹, 8.1 and 8.4 kg ha⁻¹ and 45.5 and 47.3 kg ha⁻¹ respectively). Both of these were on par with each other but significantly superior to N, P and K uptake recorded under furrow method (24.4 and 25.1 kg ha⁻¹, 6.8 and 7.0 kg ha⁻¹ and 37.5 and 38.7 kg ha⁻¹ correspondingly).

Table-4.34: : Nitrogen, phosphorus and potassium content (%) on whole plant basis at harvest in capsicum, maize and sunflower as influenced by methods of irrigation, levels and sources of fertilizers during 1994-95 and 1996-97

Treatments	Capsicum			Maize			Sunflower		
	N	P	K	N	P	K	N	P	K
	1994			1994			1995		
<u>Furrow irrigation</u>									
T ₁ 80% Rec. dose NF	2.93	0.78	4.61	1.44	0.26	1.28	1.57	0.25	1.04
T ₂ 80% Rec. dose WSF	2.91	0.82	4.59	1.12	0.26	1.29	1.56	0.25	1.04
T ₃ 100% Rec. dose NF	2.95	0.83	4.54	1.43	0.28	1.29	1.58	0.26	1.05
T ₄ 100% Rec. dose WSF	2.88	0.85	4.47	1.44	0.27	1.30	1.57	0.25	1.06
<u>Drip irrigation</u>									
T ₅ 80% Rec. dose NF	2.87	0.83	4.63	1.45	0.26	1.32	1.58	0.26	1.06
T ₆ 80% Rec. dose WSF	2.93	0.79	4.51	1.48	0.27	1.31	1.57	0.26	1.05
T ₇ 100% Rec. dose NF	2.86	0.82	4.55	1.48	0.27	1.33	1.59	0.27	1.07
T ₈ 100% Rec. dose WSF	2.87	0.78	4.53	1.47	0.28	1.32	1.60	0.26	1.07
<u>Fertigation</u>									
T ₉ 80% Rec. dose NF	2.87	0.81	4.58	1.48	0.27	1.34	1.61	0.27	1.07
T ₁₀ 80% Rec. dose WSF	2.90	0.83	4.52	1.50	0.28	1.33	1.63	0.28	1.06
T ₁₁ 100% Rec. dose NF	2.89	0.79	4.50	1.49	0.29	1.34	1.62	0.28	1.08
T ₁₂ 100% Rec. dose WSF	2.93	0.84	4.55	1.48	0.29	1.35	1.62	0.28	1.08
	NA*	NA	NA	NA	NA	NA	NA	NA	NA
	1996			1996			1997		
<u>Furrow irrigation</u>									
T ₁ 80% Rec. dose NF	2.90	0.80	4.42	1.47	0.26	1.32	1.54	0.24	1.02
T ₂ 80% Rec. dose WSF	2.94	0.78	4.44	1.47	0.25	1.34	1.55	0.25	1.03
T ₃ 100% Rec. dose NF	2.89	0.81	4.51	1.49	0.25	1.35	1.57	0.25	1.04
T ₄ 100% Rec. dose WSF	2.93	0.81	4.47	1.46	0.26	1.33	1.56	0.26	1.03
<u>Drip irrigation</u>									
T ₅ 80% Rec. dose NF	2.86	0.76	4.57	1.48	0.27	1.35	1.56	0.25	1.05
T ₆ 80% Rec. dose WSF	2.89	0.84	4.60	1.47	0.28	1.36	1.57	0.26	1.04
T ₇ 100% Rec. dose NF	2.93	0.83	4.62	1.49	0.27	1.34	1.58	0.27	1.05
T ₈ 100% Rec. dose WSF	2.90	0.82	4.59	1.49	0.26	1.36	1.59	0.26	1.06
<u>Fertigation</u>									
T ₉ 80% Rec. dose NF	2.90	0.81	4.49	1.50	0.27	1.35	1.59	0.27	1.06
T ₁₀ 80% Rec. dose WSF	2.95	0.82	4.50	1.52	0.29	1.37	1.58	0.28	1.06
T ₁₁ 100% Rec. dose NF	2.92	0.80	4.55	1.52	0.28	1.36	1.59	0.28	1.07
T ₁₂ 100% Rec. dose WSF	2.93	0.83	4.47	1.51	0.29	1.37	1.60	0.29	1.07
	NA	NA	NA	NA	NA	NA	NA	NA	NA

Table-4.35: Nitrogen, phosphorus and potassium uptake by capsicum as influenced by methods of irrigation, levels and sources of fertilizer during 1994 and 1996

Treatments	Nutrient uptake (kg/ha)					
	N		P		K	
	1994	1996	1994	1996	1994	1996
Main treatments						
Irrigation methods						
I ₁ Furrow	24.44	25.12	6.83	6.98	37.48	38.72
I ₂ Drip	28.75	29.50	8.07	8.38	45.47	47.29
I ₃ Fertigation	22.20	31.39	9.21	8.79	50.53	48.71
F test	*	*	*	*	*	*
C.D at 5%	4.15	3.91	1.60	1.12	6.16	7.42
Fertilizer levels						
L ₁ 80% Rec. dose	27.30	27.76	7.64	7.73	42.71	43.50
L ₂ 100% Rec. dose	29.63	29.58	8.43	8.37	46.27	46.32
F test	NS	NS	NS	*	*	NS
C.D at 5%	-	-	-	0.52	3.43	-
Fertilizer sources						
S ₁ NF	28.11	28.35	7.97	7.93	44.26	44.55
S ₂ WSF	28.82	28.99	8.10	8.17	44.72	45.27
F test	NS	NS	NS	NS	NS	NS
C.D at 5%	-	-	-	-	-	-
Combined treatments						
Furrow irrigation						
T ₁ 80% Rec. dose NF	22.68	23.51	5.97	6.48	34.34	36.50
T ₂ 80% Rec. dose WSF	23.41	24.80	6.31	6.71	35.63	37.87
T ₃ 100% Rec. dose NF	26.54	25.60	7.61	7.28	41.27	39.96
T ₄ 100% Rec. dose WSF	25.14	26.5	7.42	7.45	38.67	40.55
Drip irrigation						
T ₅ 80% Rec. dose NF	26.83	27.87	7.86	7.61	43.64	45.17
T ₆ 80% Rec. dose WSF	27.75	28.45	7.58	8.27	43.15	45.89
T ₇ 100% Rec. dose NF	29.82	31.25	8.55	8.95	47.03	49.17
T ₈ 100% Rec. dose WSF	30.59	30.43	8.31	8.70	48.05	48.96
Fertigation						
T ₉ 80% Rec. dose NF	30.69	30.35	8.86	8.56	49.44	46.84
T ₁₀ 80% Rec. dose WSF	32.42	31.58	9.28	8.78	50.08	48.75
T ₁₁ 100% Rec. dose NF	32.10	31.52	8.97	8.73	49.87	49.68
T ₁₂ 100% Rec. dose WSF	33.60	32.13	9.73	9.10	52.72	49.58
F test	NS	NS	NS	NS	NS	NS
C.D. at 5%	-	-	-	-	-	-

* = Significant
NS = Non-significant

NF = Normal fertilizer
WSF = water soluble fertilizer

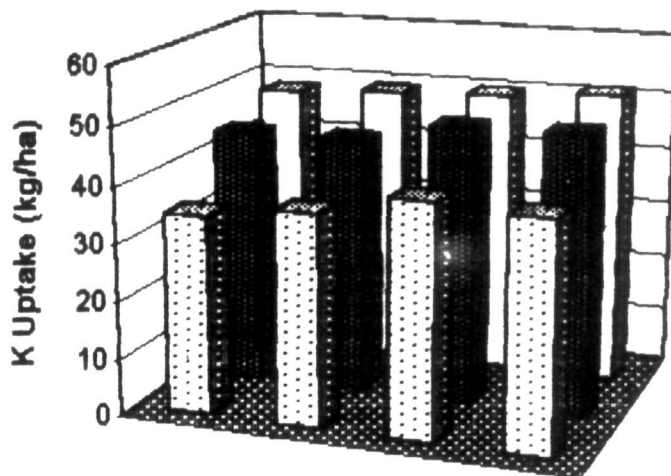
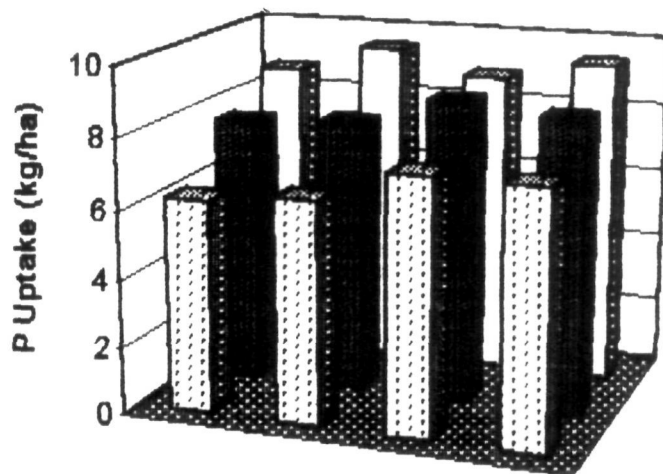
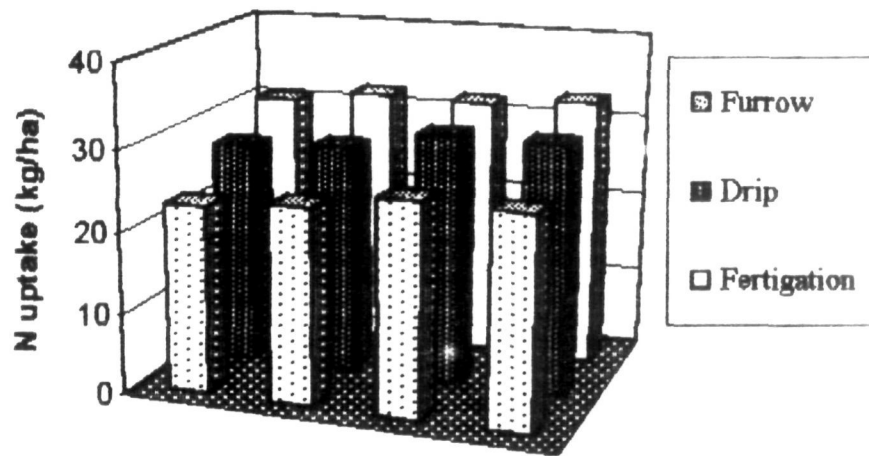

Fig 4.14 N, P and K uptake in capsicum as influenced by fertigation, drip and furrow with levels and sources of fertilizer (mean of two years)

Data on uptake of nutrients in sunflower showed significant improvement with respect P uptake (8.67 kg ha^{-1}) in 1996 and K uptake (46.3 kg ha^{-1}) in 1994 due to full (100%) dose fertilizer over the reduced (80%) dose which recorded 7.7 kg and 42.7 kg ha^{-1} respectively.

Higher N, P and K uptake recorded with WSF source was not significant as compared to the uptake obtained with NF source. Similarly the variation due to treatment interactions on uptake of N (22.7 to 33.6 kg ha^{-1}), P (6.0 to 9.7 kg ha^{-1}) and K (34.3 - 52.7 kg ha^{-1}) over the two years of observation was also non-significant.

4.9.3 N, P and K uptake in maize (kg/ha)

Data on N, P and K uptake in maize as influenced by methods of irrigation, levels and sources of fertilizer are presented in Table-4.36.

The highest N (180.8 and 188.0 kg ha^{-1}), P (34.3 and 35.1 kg ha^{-1}) and K (163.1 and 170.0 kg ha^{-1}) uptake recorded under fertigation respectively during 1994 and 1996 followed by drip method which registered 166.6 and 157.6 kg ha^{-1} (N), 30.6 and 31.4 kg ha^{-1} (P) and 149.3 and 157.6 kg ha^{-1} (K) uptake correspondingly were significantly superior to N (147.4 and 155.6 kg ha^{-1}), P (27.5 and 27.0 kg ha^{-1}) and K (132.7 and 141.3 kg ha^{-1}) uptake recorded under furrow method except the K uptake in 1994 (Table-4.36). However, fertigation and drip treatments were on par with each other in terms of N uptake in 1994 and K uptake in both the years (Fig. 4.15).

Between fertilizer levels 100% dose had significantly higher uptake of P only in 1994 from 29.1 kg ha^{-1} in 80% dose to 32.5 kg ha^{-1} . However, higher uptake of N, K and P in 1996 due to full dose fertilizer over reduced dose was not significant.

Table-4.36: Nitrogen, phosphorus and potassium uptake by maize as influenced by methods of irrigation, levels and sources of fertilizer during 1994 and 1996

Treatments	Nutrient uptake (kg/ha)					
	N		P		K	
	1994	1996	1994	1996	1994	1996
Main treatments						
Irrigation methods						
I ₁ Furrow	147.4	155.6	27.5	27.0	132.7	141.3
I ₂ Drip	166.6	172.8	30.6	31.4	149.3	157.6
I ₃ Fertigation	180.8	188.0	34.3	35.1	163.1	170.0
F test	*	*	*	*	*	*
C.D at 5%	15.9	14.6	2.8	3.6	16.8	14.1
Fertilizer levels						
L ₁ 80% Rec. dose	159.7	166.8	29.1	30.4	143.1	151.6
L ₂ 100% Rec. dose	170.1	177.5	32.5	31.9	153.7	161.0
F test	NS	NS	*	NS	NS	NS
C.D at 5%	-	-	2.0	-	-	-
Fertilizer sources						
S ₁ NF	164.5	172.1	30.6	30.8	148.1	155.8
S ₂ WSF	165.4	172.1	31.1	31.5	148.7	156.8
F test	NS	NS	NS	NS	NS	NS
C.D at 5%	-	-	-	-	-	-
Combined treatments						
Furrow irrigation						
T ₁ 80% Rec. dose NF	142.1	149.5	25.6	26.6	126.3	135.2
T ₂ 80% Rec. dose WSF	142.3	148.8	26.1	25.3	129.3	135.6
T ₃ 100% Rec. dose NF	152.0	162.1	29.8	27.2	137.1	146.9
T ₄ 100% Rec. dose WSF	153.2	162.0	28.7	27.8	138.3	147.6
Drip irrigation						
T ₅ 80% Rec. dose NF	158.2	166.2	28.3	30.3	142.5	151.6
T ₆ 80% Rec. dose WSF	159.8	168.1	29.1	32.0	141.7	155.5
T ₇ 100% Rec. dose NF	175.8	179.5	32.1	32.5	158.0	161.4
T ₈ 100% Rec. dose WSF	172.7	177.3	32.9	30.9	155.0	161.8
Fertigation						
T ₉ 80% Rec. dose NF	175.6	184.5	32.0	33.2	158.9	166.0
T ₁₀ 80% Rec. dose WSF	180.4	183.6	33.7	35.0	160.0	165.5
T ₁₁ 100% Rec. dose NF	183.3	191.1	35.7	35.2	166.1	173.5
T ₁₂ 100% Rec. dose WSF	183.8	192.8	36.0	37.0	167.6	174.9
F test	NS	NS	NS	NS	NS	NS
C.D. at 5%	-	-	-	-	-	-

* = Significant
NS = Non-significant

NF = Normal fertilizer
WSF = Water soluble fertilizer

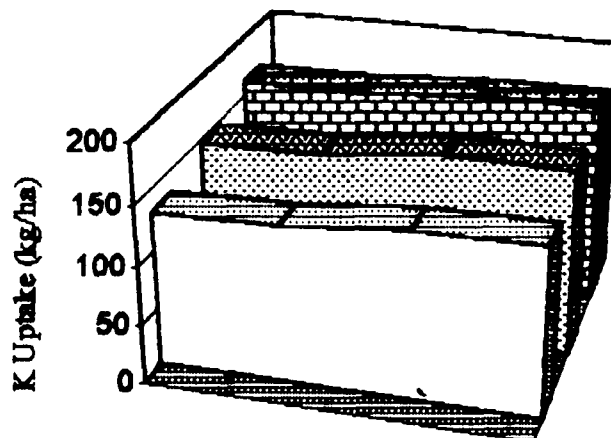
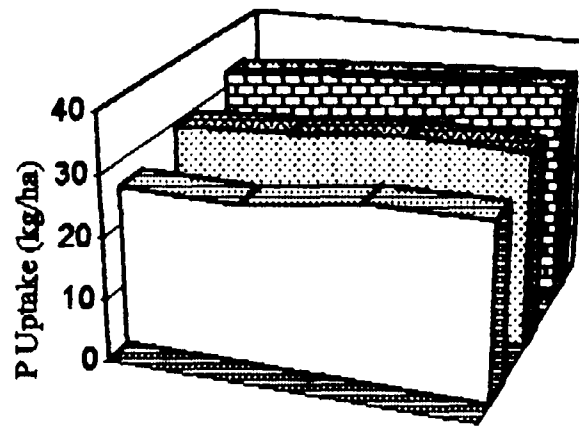
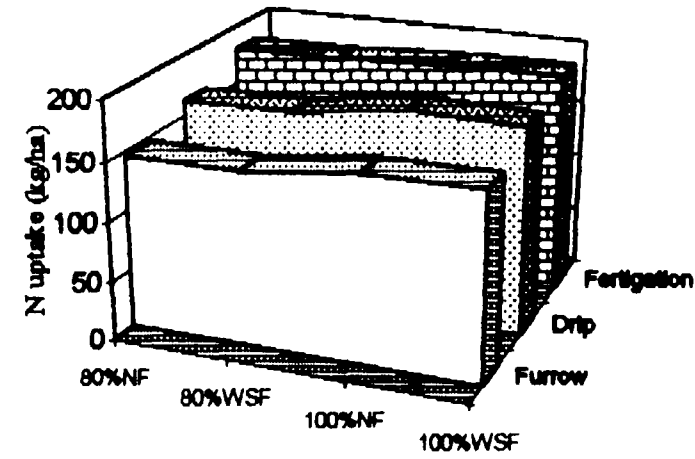

Fig. 4.15 : N,P and K uptake in maize as influenced by fertigation, drip and furrow with levels and sources of fertilizer (mean of two years)

WSF and NF sources did not differ between themselves with respect to nutrient uptake. Similarly N, P and K uptake in maize was not influenced significantly by different interaction effects.

4.9.4 N, P and K uptake in sunflower

The data on nitrogen, phosphorus and potassium uptake by sunflower as influenced by methods of irrigation, levels and sources of fertilizer are presented in Table-4.37 and Fig. 4.16.

N, P and K uptake was considerably influenced due to irrigation methods. Imposition of fertigation significantly increased N uptake from 84.6 kg ha⁻¹ (1995) and 78.1 kg ha⁻¹ (1997) in furrow irrigation to 101.2 kg ha⁻¹ and 93.2 kg ha⁻¹ respectively. N uptake of 96.2 kg ha⁻¹ and 88.6 kg ha⁻¹ observed with drip treatment was also significantly superior to furrow but was on par with fertigation.

P uptake values were 17.4 and 16.4 kg ha⁻¹ for fertigation, 15.9 and 14.6 kg ha⁻¹ for drip and 13.6 and 12.6 kg ha⁻¹ for furrow methods in 1995 and 1997 respectively indicating significant superiority of fertigation over furrow irrigation. However, drip method was also superior to furrow method in both the years but on par with fertigation only in 1995.

Significantly higher K uptake of 67.0 and 62.5 kg ha⁻¹ in 1995 and 1997 respectively by fertigated sunflower and 64.5 and 59.0 kg ha⁻¹ respectively under drip method was observed as compared to 56.3 kg and 51.7 kg ha⁻¹ K uptake obtained with furrow method.

Increased N, P and K uptake was recorded with increased dose of fertilizer (100%) as compared to reduced dose (80%) but not significantly. Similarly, the marginal increase in nutrient uptake because of WSF source over NF source was also non-significant (Table-4.37).

Table-4.37: Nitrogen, phosphorus and potassium uptake by sunflower as influenced by methods of irrigation, levels and sources of fertilizer during 1995 and 1997

Treatments	Nutrient uptake (kg/ha)					
	N		P		K	
	1995	1997	1995	1997	1995	1997
<u>Main treatments</u>						
<u>Irrigation methods</u>						
I ₁ Furrow	84.6	78.1	13.6	12.6	56.3	51.7
I ₂ Drip	96.2	88.6	15.9	14.6	64.5	59.0
I ₃ Fertigation	101.2	93.2	17.4	16.4	67.0	62.5
F test	*	*	*	*	*	*
C.D at 5%	10.3	8.8	1.7	1.5	6.9	6.0
<u>Fertilizer levels</u>						
L ₁ 80% Rec. dose	91.3	88.4	15.1	13.8	60.6	55.6
L ₂ 100% Rec. dose	96.6	89.9	16.1	15.3	64.6	59.9
F test	NS	NS	NS	NS	NS	NS
C.D at 5%	-	-	-	-	-	-
<u>Fertilizer sources</u>						
S ₁ NF	93.7	86.5	15.6	14.4	62.5	57.7
S ₂ WSF	94.2	86.8	15.6	14.7	62.7	57.8
F test	NS	NS	NS	NS	NS	NS
C.D at 5%	-	-	-	-	-	-
<u>Combined treatments</u>						
<u>Furrow irrigation</u>						
T ₁ 80% Rec. dose NF	81.7	74.0	13.1	11.5	54.1	49.0
T ₂ 80% Rec. dose WSF	78.4	76.1	12.6	12.3	52.3	50.6
T ₃ 100% Rec. dose NF	90.6	83.0	14.9	13.2	60.1	55.0
T ₄ 100% Rec. dose WSF	87.5	79.2	13.9	13.2	58.8	52.3
<u>Drip irrigation</u>						
T ₅ 80% Rec. dose NF	94.0	85.3	15.5	13.7	63.1	57.4
T ₆ 80% Rec. dose WSF	94.3	83.1	15.6	13.8	63.0	55.0
T ₇ 100% Rec. dose NF	94.8	91.8	16.0	15.7	63.4	61.1
T ₈ 100% Rec. dose WSF	102.1	93.9	16.6	15.3	68.3	62.6
<u>Fertigation</u>						
T ₉ 80% Rec. dose NF	98.0	90.0	16.4	15.3	65.1	60.0
T ₁₀ 80% Rec. dose WSF	101.3	91.7	17.4	16.2	65.9	61.5
T ₁₁ 100% Rec. dose NF	103.4	94.6	17.9	16.7	68.9	62.7
T ₁₂ 100% Rec. dose WSF	102.0	96.7	17.6	17.5	68.0	64.6
F test	NS	NS	NS	NS	NS	NS
C.D. at 5%	-	-	-	-	-	-

* = Significant
NS = Non-significant

NF = Normal fertilizer
WSF = Water soluble fertilizer

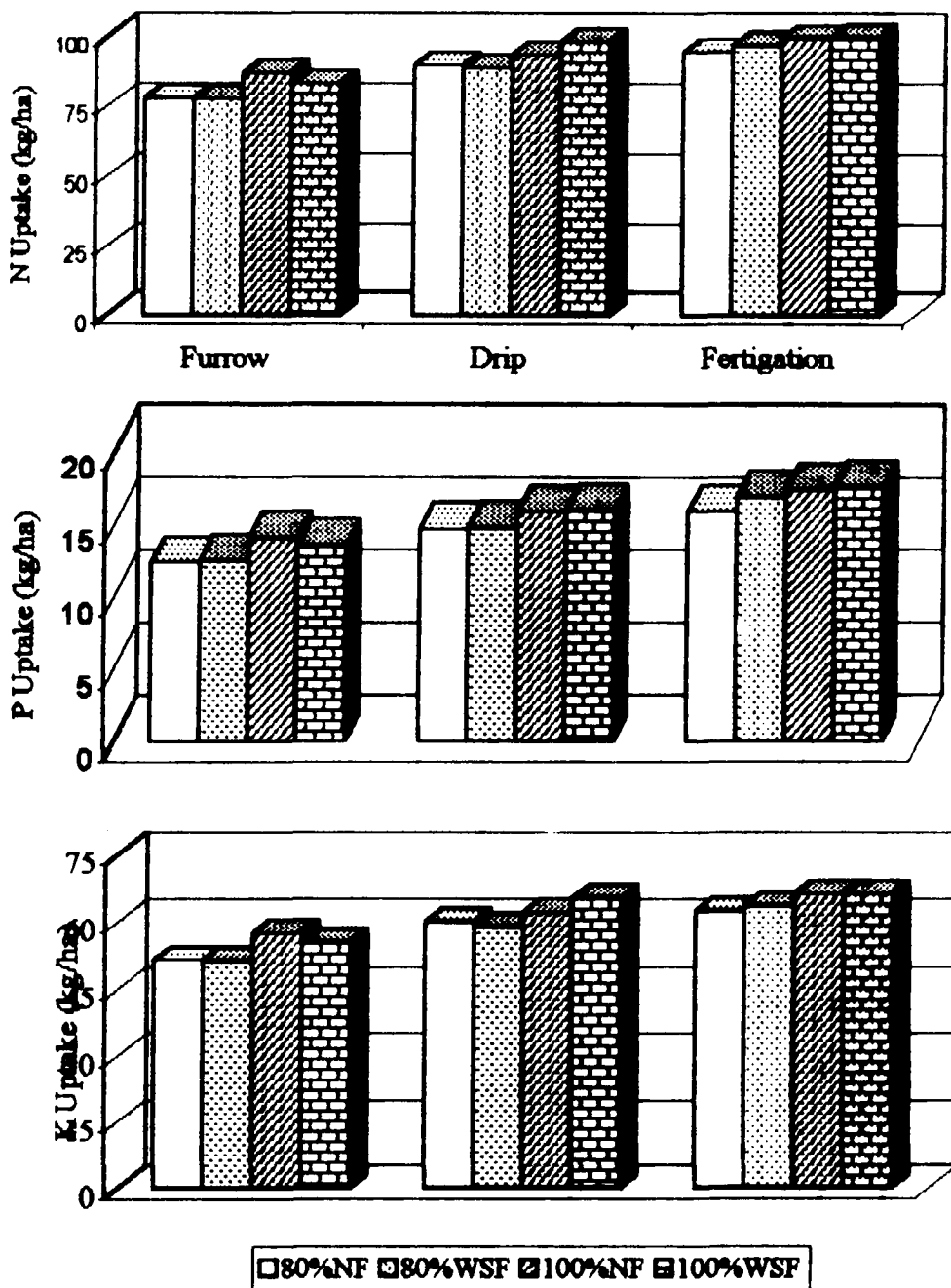

Fig 4.16 : N, P and K uptake in sunflower as influenced by fertigation, drip and furrow with levels and sources of fertilizer (mean of two years)

None of the interactions was found significant with respect to nutrient uptake although N, P and K uptake values varied from 74.0-103.4 kg ha⁻¹, 11.5-17.9 kg ha⁻¹ and 49.0 to 68.9 kg ha⁻¹ respectively over the two years of observation.

4.9.5 Fertilizer use efficiency in capsicum, maize and sunflower

Data on fertilizer use efficiency (kg yield per kg NPK fertilizer) in capsicum, maize and sunflower as influenced by methods of irrigation levels and sources of fertilizer are presented in Table-4.38 and illustrated in Fig. 4.17.

Fertilizer use efficiency in Capsicum

Green fruit yield in capsicum responded significantly to methods of irrigation and fertilizer application. Fertilizer use efficiency of 38.7 and 38.8 kg per kg NPK in 1994 and 1996 respectively under fertigation followed by 35.2 and 35.7 kg per kg NPK respectively obtained with drip method was significantly superior over 31.2 and 31.4 kg yield per kg NPK achieved by furrow irrigation. However, both fertigation and drip treatment were on par with each other.

Fertilizer application at 80% recommended dose was significantly superior in recording higher FUE in both 1994 and 1996 (38.5 and 28.4 kg per kg NPK) as compared to 100% dose (31.6 and 31.6 kg per kg NPK respectively).

FUE did not differ between NF or WSF sources. So also the interaction effects were on par although higher FUE values (43.4-33/8 kg per kg NPK) were recorded with fertigation combinations than drip (31.9-39.4 kg per kg NPK) or furrow (28.1-34.7 kg per kg NPK) methods during both the years 1994 and 1996.

Table-4.38: Fertilizer use efficiency in capsicum, maize and sunflower as influenced by methods of irrigation, levels and sources of fertilizer

Treatments	Fertilizer use efficiency (kg yield/kg NPK fertilizer)					
	Capsicum		Maize		Sunflower	
	1994	1996	1994	1996	1995	1997
Main treatments						
Irrigation methods						
I ₁ Furrow	31.18	31.43	17.04	17.22	7.55	6.95
I ₂ Drip	35.23	35.75	18.30	18.42	8.47	7.67
I ₃ Fertigation	38.73	37.79	19.40	19.27	9.45	8.16
F test	*	*	*	*	*	*
C.D at 5%	3.88	4.25	1.39	1.45	1.09	0.91
Fertilizer levels						
L ₁ 80% Rec. dose	38.51	38.37	19.99	20.08	9.00	8.21
L ₂ 100% Rec. dose	31.58	31.61	16.51	16.53	7.71	6.98
F test	*	*	*	*	*	*
C.D at 5%	3.57	3.46	0.94	0.97	0.90	0.99
Fertilizer sources						
S ₁ NF	35.19	35.03	18.28	18.37	8.40	7.54
S ₂ WSF	34.90	34.95	18.22	18.24	8.30	7.65
F test	NS	NS	NS	NS	NS	NS
C.D at 5%	-	-	-	-	-	-
Combined treatments						
Furrow irrigation						
T ₁ 80% Rec. dose NF	34.19	34.73	18.83	19.52	8.28	7.32
T ₂ 80% Rec. dose WSF	33.88	34.17	18.48	18.33	7.82	7.60
T ₃ 100% Rec. dose NF	28.53	28.58	15.39	15.64	7.12	6.60
T ₄ 100% Rec. dose WSF	28.11	28.24	15.47	15.40	6.97	6.29
Drip irrigation						
T ₅ 80% Rec. dose NF	38.64	39.39	19.91	20.09	9.00	8.40
T ₆ 80% Rec. dose WSF	38.34	39.11	20.03	20.13	9.30	8.06
T ₇ 100% Rec. dose NF	32.09	32.09	16.79	16.62	7.99	6.94
T ₈ 100% Rec. dose WSF	31.89	32.43	16.49	16.86	7.59	7.27
Fertigation						
T ₉ 80% Rec. dose NF	43.34	41.62	21.47	21.09	9.91	8.74
T ₁₀ 80% Rec. dose WSF	42.64	41.21	21.24	21.34	9.69	9.13
T ₁₁ 100% Rec. dose NF	34.33	33.76	17.28	17.25	8.13	7.24
T ₁₂ 100% Rec. dose WSF	34.55	34.56	17.62	17.40	8.46	7.53
F test	NS	NS	NS	NS	NS	NS
C.D. at 5%	-	-	-	-	-	-

* = Significant
NS = Non significant

NF = Normal fertilizer
WSF = Water soluble fertilizer

Fertilizer use efficiency in Maize

FUE under the influence of irrigation water and fertilizer application methods showed that fertigation was significantly superior which recorded 19.4 and 19.3 kg yield per kg NPK respectively in 1994 and 1996 as compared to furrow method (17.0 and 17.2 kg per kg NPK respectively). The drip method with FUE of 18.3 and 18.4 kg per kg NPK correspondingly was on par with both fertigation and furrow method.

Highest FUE of 20.0 and 20.1 kg per kg NPK for 1994 and 1996 respectively recorded with 80% dose was significant as compared to 16.5 kg per kg NPK in both the years obtained with 100% dose.

Neither the sources of fertilizer nor the treatment interactions were found significant in influencing the fertilizer use efficiency.

Fertilizer use efficiency in Sunflower

Fertigation favoured high FUE in both 1995 and 1997 (4.0 and 8.2 kg per kg NPK) followed by drip (8.5 and 7.7 kg per kg NPK) and the former being significantly superior to furrow method (7.5 and 6.9 kg per kg NPK correspondingly). However, the drip treatment was on par with both fertigation and furrow method.

Reduced dose (80%) fertilizer was significantly higher by recording 9.0 and 8.2 kg per kg NPK FUE than the full dose (100%) which registered 7.7 and 7.0 kg per kg NPK correspondingly. However, FUE variation due to WSF or NF or interactions between treatments were not statistically significant.

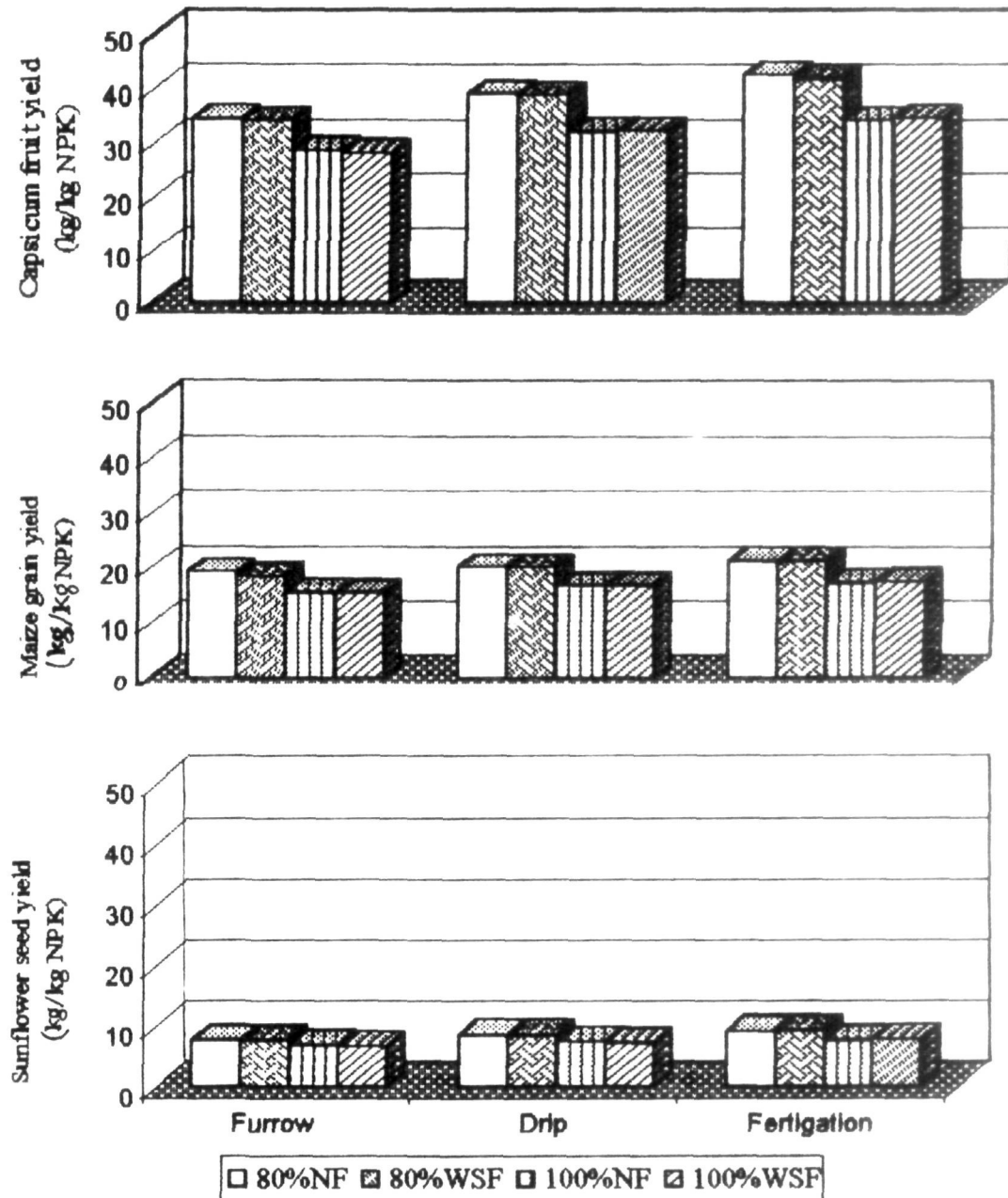

Fig.4.17 : Fertilizer Use Efficiency (kg yield/ kg NPK) in capsicum, maize and sunflower as influenced by fertigation, drip and furrow with levels and sources of fertilizer (mean of two years)

4.10 Soil moisture study and Irrigation Water Use Efficiency

4.10.1 Soil moisture distribution

Per cent soil moisture distribution under furrow, drip and fertigation systems in the experimental plot recorded at 24 hours after irrigation is presented in Table-4.39.

During both the years 1994 and 1996 relatively lower moisture content was noticed under furrow irrigated plots (16.9 to 22.2%) as compared to drip (18.7 to 26.6%) and fertigation (20.2 to 28.2%) in top 0-30 cm layer. Under furrow method, moisture content increased with depth reaching maximum values at 30-60 cm soil profile. However, under drip/fertigated plots, uniform distribution of moisture was noticed upto 60 cm depth with slight variation at each depth. In general, the fertigated plots did not differ to a considerable extent with respect to soil moisture content as compared to drip irrigated plots.

4.10.2 Irrigation water use efficiency (kg M^{-3})

Irrigation water use efficiency (IWUE) was influenced by different irrigation and fertilization methods (Table-4.40). Fertigation treatment recorded significantly higher IWUE in capsicum, maize and sunflower crops in both the years 1994-95 and 1996-97 (Fig. 4.18).

In capsicum IWUE recorded under fertigation was significantly superior (2.02-2.34 kg M^{-3}) to furrow (1.29-1.53 kg M^{-3}) but was on par with drip method (1.86-2.22 kg M^{-3}) which in turn was significantly higher than furrow method. Corresponding values in maize 1.35-1.26 kg M^{-3} , 0.92-0.89 kg M^{-3} and 1.28-1.21 kg M^{-3} showed the similar trend as observed in capsicum.

Fertigation in sunflower significantly increased the IWUE from 0.18 kg M^{-3} in furrow to 0.29 kg M^{-3} in 1995 and 0.27 kg M^{-3} in 1997. Drip irrigation with 0.27 kg M^{-3} and 0.25 kg M^{-3} during 1995 and 1997 respectively was also superior to furrow but was equal to fertigation.

Table-4.39 : Soil moisture status in 0-60 cm layer as influenced by methods of irrigation

		Soil moisture (%)					
Radial distance (cm)		0-10	10-20	20-30	0-10	10-20	20-30
Soil depth (cm)	1994			1996			
		<u>Furrow</u>			<u>Furrow</u>		
0-15	19.35	18.84	16.93	17.87	18.27	18.10	
15-30	20.82	20.55	18.36	21.35	22.19	20.35	
30-45	25.56	24.60	23.72	25.86	26.36	24.78	
45-60	24.73	23.29	21.90	24.51	23.17	22.75	
	<u>Drip</u>			<u>Drip</u>			
0-15	26.65	24.51	20.89	27.24	25.83	22.10	
15-30	25.17	26.10	18.75	27.26	26.05	17.36	
30-45	22.23	21.75	16.51	24.13	23.15	16.15	
45-60	21.74	18.57	15.47	22.12	19.83	16.38	
	<u>Fertigation</u>			<u>Fertigation</u>			
0-15	26.13	24.31	21.17	28.18	25.56	23.75	
15-30	25.29	24.85	17.36	27.34	25.50	20.17	
30-45	23.18	22.74	17.10	25.26	22.19	18.36	
45-60	20.35	20.00	15.69	21.76	20.31	16.26	

Table-4.40: Irrigation water use efficiency in capsicum, maize and sunflower as influenced by methods of irrigation, levels and sources of fertilizer

Treatments	Irrigation water use efficiency (Kg yield/M ³ water)					
	Capsicum		Maize		Sunflower	
	1994	1996	1994	1996	1995	1997
<u>Main treatments</u>						
<u>Irrigation methods</u>						
I ₁ Furrow	1.29	1.53	0.92	0.89	0.18	0.18
I ₂ Drip	1.86	2.22	1.28	1.21	0.27	0.25
I ₃ Fertigation	2.02	2.34	1.35	1.26	0.29	0.27
F test	*	*	*	*	*	*
C.D at 5%	0.26	0.25	0.11	0.12	0.06	0.04
<u>Fertilizer levels</u>						
L ₁ 80% Rec. dose	1.70	2.00	1.16	1.11	0.24	0.23
L ₂ 100% Rec. dose	1.75	2.06	1.20	1.13	0.26	0.24
F test	NS	NS	*	NS	NS	NS
C.D at 5%	-	-	0.03	-	-	-
<u>Fertilizer sources</u>						
S ₁ NF	1.73	2.03	1.19	1.12	0.25	0.23
S ₂ WSF	1.72	2.03	1.18	1.12	0.25	0.23
F test	NS	NS	NS	NS	NS	NS
C.D at 5%	-	-	-	-	-	-
<u>Combined treatments</u>						
<u>Furrow irrigation</u>						
T ₁ 80% Rec. dose NF	1.27	1.51	0.92	0.89	0.18	0.17
T ₂ 80% Rec. dose WSF	1.26	1.49	0.90	0.88	0.17	0.17
T ₃ 100% Rec. dose NF	1.33	1.56	0.94	0.90	0.20	0.19
T ₄ 100% Rec. dose WSF	1.31	1.54	0.94	0.89	0.19	0.18
<u>Drip irrigation</u>						
T ₅ 80% Rec. dose NF	1.83	2.20	1.25	1.19	0.26	0.25
T ₆ 80% Rec. dose WSF	1.82	2.18	1.25	1.19	0.27	0.24
T ₇ 100% Rec. dose NF	1.90	2.24	1.32	1.23	0.29	0.26
T ₈ 100% Rec. dose WSF	1.89	2.26	1.29	1.24	0.27	0.27
<u>Fertigation</u>						
T ₉ 80% Rec. dose NF	1.99	2.32	1.34	1.24	0.29	0.26
T ₁₀ 80% Rec. dose WSF	2.02	2.30	1.33	1.26	0.28	0.27
T ₁₁ 100% Rec. dose NF	2.03	2.35	1.36	1.27	0.28	0.27
T ₁₂ 100% Rec. dose WSF	2.05	2.41	1.38	1.28	0.30	0.28
F test	NS	NS	NS	NS	NS	NS
C.D. at 5%	-	-	-	-	-	-

* = Significant
NS = Non-significant

NF = Normal fertilizer
WSF = Water soluble fertilizer

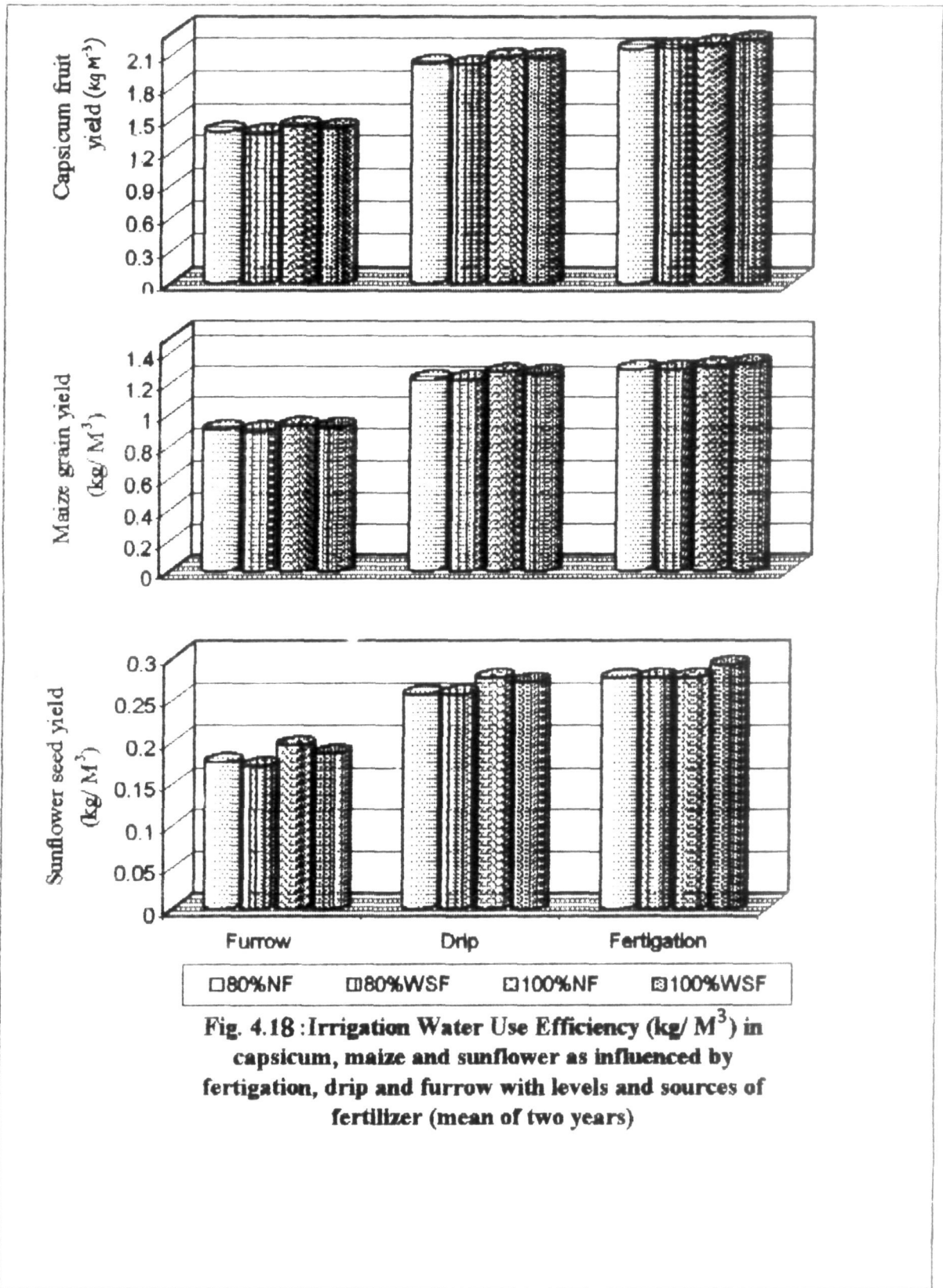

Both the drip irrigation and fertigation resulted in nearly 43-50 per cent, 36-50 per cent and 44-55 per cent increase in IWUE in capsicum, maize and sunflower respectively. The higher IWUE recorded with 100% recommended dose as compared to 80% recommended dose was significant only in maize during 1994, wherein the respective values were 1.10 kg M^{-3} and 1.16 kg M^{-3} . Fertilizer sources of WSF or NF did not differ in terms of IWUE.

The fertigation combinations with levels and sources of fertilizers registered IWUE of $1.99\text{-}2.41 \text{ kg M}^{-3}$, $1.24\text{-}1.38 \text{ kg M}^{-3}$ and $0.26\text{-}0.30 \text{ kg M}^{-3}$ in capsicum, maize and sunflower as compared to $1.26\text{-}1.56 \text{ kg M}^{-3}$, $0.89\text{-}0.94 \text{ kg M}^{-3}$ and $0.17\text{-}0.20 \text{ kg M}^{-3}$ correspondingly. However, the variations were not statistically significant. In particular, the highest IWUE was obtained with 100% WSF supplied in fertigation method whereas the least IWUE was observed with 80% WSF in furrow irrigation for all the three crops.

4.11 Root distribution pattern in capsicum, maize and sunflower as influenced by methods of irrigation and fertilization sources and levels of fertilizer

4.11.1 Root dry weight in capsicum, maize and sunflower

Data on root dry weight (g/plant) in capsicum, maize and sunflower recorded at final harvest as influenced by different treatments under study is presented in Table-4.41.

Fertigated capsicum plants had higher root dry weight in both the years (5.39 to $5.35 \text{ g plant}^{-1}$) as compared to 5.14 to $4.93 \text{ g plant}^{-1}$ in drip irrigation and 5.03 to $5.28 \text{ g plant}^{-1}$ in furrow method. However, in particular the fertigation at 100% dose as WSF recorded maximum root dry weight of 5.51 and $5.43 \text{ g plant}^{-1}$ in 1994 and 1996 respectively while the minimum root dry weight of 4.77 and 5.08 were observed under 80% dose NF applied in furrow method.

Table 4.41 Root dry weight in capsicum, maize and sunflower at final harvest as influenced by methods of irrigation, levels and sources of fertilizer

Treatments	Root dry weight (g/plant)					
	Capsicum		Maize		Sunflower	
	1994	1996	1994	1996	1995	1997
<u>Furrow irrigation</u>						
T ₁ 80% Rec. dose NF	4.77	5.08	52.29	54.16	31.81	28.53
T ₂ 80% Rec. dose WSF	4.93	5.21	57.53	55.25	29.25	27.25
T ₃ 100% Rec. dose NF	5.30	5.38	63.85	55.32	34.07	30.84
T ₄ 100% Rec. dose WSF	5.12	5.46	61.32	59.84	32.19	32.32
Mean	5.03	5.28	58.75	56.14	31.83	29.13
<u>Drip irrigation</u>						
T ₅ 80% Rec. dose NF	4.95	4.82	57.85	58.12	32.54	26.56
T ₆ 80% Rec. dose WSF	5.51	4.98	54.24	57.23	33.29	30.25
T ₇ 100% Rec. dose NF	5.23	5.02	61.53	63.80	36.56	31.02
T ₈ 100% Rec. dose WSF	5.37	4.90	63.65	60.75	36.38	31.84
Mean	5.14	4.93	59.32	59.94	34.69	30.42
<u>Fertigation</u>						
T ₉ 80% Rec. dose NF	5.40	5.30	62.38	56.36	34.85	34.35
T ₁₀ 80% Rec. dose WSF	5.29	5.38	58.45	62.45	36.37	33.24
T ₁₁ 100% Rec. dose NF	5.38	5.29	64.38	59.24	35.78	34.15
T ₁₂ 100% Rec. dose WSF	5.51	5.43	64.36	60.55	35.72	35.39
Mean	5.39	5.35	62.44	59.65	36.03	34.28

NF = Normal Fertilizer

WSF = Water Soluble Fertilizer

In maize also, combining irrigation with fertilization resulted in increased root dry weight in both the years from 58.7 to 56.1 g plant⁻¹ in furrow irrigation and 59.3 to 59.9 g plant⁻¹ in drip method to 62.4 to 59.6 g plant⁻¹ correspondingly. Further, in 1994, the treatment involving 100% WSF fertigation produced 64.56 g plant⁻¹ root dry weight as compared to 52.29 g plant⁻¹ in 80% NF supplied in furrow method. Where as in 1996, the maximum root dry weight (62.45 g plant⁻¹) was associated with 80% WSF fertigation in comparison with 54.16 g plant⁻¹ recorded under 80% NF in furrow irrigation.

Root dry weight in sunflower indicated that fertigation was favourable for higher root growth as the values 36.0 and 34.3 g plant⁻¹ were higher than 34.7 and 30.4 g plant⁻¹ and 31.8 and 29.7 g plant⁻¹ observed with drip and furrow methods respectively. Root dry was relatively lower in 1997 than in 1995.

Among the individual treatments, it was the 100% WSF fertigation which recorded the highest root dry weight (37.1 and 35.4 g plant⁻¹ in both 1995 and 1997. Whereas the 80% WSF applied in furrow method had the least root mass (29.2 and 27.2 g plant⁻¹) than rest of the treatments. Fertilizer levels as full dose (100%) or reduced dose (80%) and NF or WSF as fertilizer sources did not cause considerable variation with respect to root dry weight in all the three crops.

4.11.2 Root distribution pattern in capsicum, maize and sunflower

Data on root dry weight (g plant⁻¹) in capsicum, maize and sunflower crops in relation to soil depth during 1994-95 and 1996-97 are presented in Table-4.42. The data revealed that there is a decrease in root density with all the treatments as the soil depth increased.

In capsicum, under fertigation, maximum root concentration of 3.30 to 3.4 g plant⁻¹ was observed in the top 0-10 cm layer which further decreased to 1.93 to 2.01 g plant⁻¹ in 10-20 cm

Table 4.42: Root mass distribution in capsicum, maize and sunflower as influenced by methods of irrigation, levels and sources of fertilizer in relation to soil depth

Treatments	Capsicum						Maize						Sunflower						
	1994			1996			1994			1996			1995			199			
	Soil depth		Soil depth	Soil depth		Soil depth	Soil depth		Soil depth	Soil depth		Soil depth	Soil depth		Soil depth	Soil depth			
<u>Furrow Irrigation</u>	0-10	10-20	0-10	10-20	20-30	0-10	10-20	20-30	0-10	10-20	20-30	0-10	10-20	20-30	0-10	10-20	20-30		
T ₁ : 80% R.D. NF	2.13	2.37	2.23	2.37	2.23	0.48	2.25	19.23	10.81	20.15	11.78	22.23	11.78	13.45	14.11	4.25	12.25	11.31	
T ₂ : 80% R.D. WSF	2.25	2.26	2.40	2.26	2.40	0.55	25.31	21.18	11.04	23.24	13.48	18.53	13.48	12.26	11.67	5.32	11.32	10.81	
T ₃ : 100% R.D. NF	2.35	2.39	2.30	2.39	2.30	0.69	26.25	22.36	15.26	24.32	9.48	21.16	9.48	15.32	12.60	6.15	12.46	13.31	
T ₄ : 100% R.D. WSF	2.40	2.35	2.51	2.35	2.51	0.60	23.51	25.65	12.16	23.56	15.04	21.94	15.04	13.85	14.41	3.43	13.27	13.31	
<u>Drip Irrigation</u>																			
T ₅ : 80% R.D. NF	2.99	2.93	1.68	2.93	1.68	0.21	33.36	21.28	4.10	33.73	19.18	19.18	5.21	17.74	11.82	2.98	16.68	8.73	
T ₆ : 80% R.D. WSF	2.96	2.98	1.77	2.98	1.77	0.23	30.22	18.06	5.96	31.24	20.35	20.35	5.64	18.38	12.15	2.76	18.34	9.23	
T ₇ : 100% R.D. NF	3.15	3.09	1.83	3.09	1.83	0.10	35.56	20.36	5.62	37.18	22.26	22.26	4.24	20.23	13.27	3.06	16.56	11.31	
T ₈ : 100% R.D. WSF	3.15	2.93	1.78	2.93	1.78	0.19	36.31	21.28	6.06	33.32	23.17	23.17	4.26	20.05	13.35	2.98	15.28	13.31	
<u>Fertigation</u>																			
T ₉ : 80% R.D. NF	3.21	3.30	1.93	3.30	1.93	0.07	36.25	22.19	3.94	31.47	20.34	20.34	4.55	22.25	10.53	2.07	19.57	12.31	
T ₁₀ : 80% R.D. WSF	3.45	3.38	1.90	3.38	1.90	0.10	33.17	20.74	4.56	34.36	24.53	24.53	3.56	21.02	12.62	2.93	18.46	11.31	
T ₁₁ : 100% R.D. NF	3.40	3.19	2.01	3.19	2.01	0.09	37.28	22.81	4.29	32.41	22.28	22.28	4.55	19.54	13.01	3.23	19.24	11.31	
T ₁₂ : 100% R.D. WSF	3.67	3.34	1.99	3.34	1.99	0.10	37.15	23.39	4.02	35.58	21.77	21.77	3.20	22.23	12.03	2.86	20.32	12.31	

NF = Normal Fertilizer WSF = Water Soluble Fertilizer

depth. A negligible root concentration of 0.07-0.10 g plant⁻¹ was recorded at the lowest soil depth of 20-30 cm. Corresponding values of 2.93 to 3.09 g, 1.68 to 1.83 g and 0.10-0.23 g plant⁻¹ in drip irrigation showed similar trends as observed in fertigation. However, the values of 2.26 to 2.35g, 2.30 to 2.51 g and 0.48 to 0.69 g plant⁻¹ correspondingly for furrow irrigation indicated root distribution upto 0-20 cm soil depth as compared to high root proliferation upto only 0-10 cm in case of drip or fertigation (Fig. 4.19). The varied fertilizer levels or fertilizer sources induced little variation on rooting pattern in capsicum during both 1994 and 1996.

Root density in maize in relation to soil depth from plant base as influenced by fertigation and non-fertigation during the years 1994 and 1996 indicated that the root density was concentrated much within 0-20 cm soil depth with fertigated treatment whereas, the root concentration was between 0-30 cm depth of soil with furrow irrigation (Fig.4.19).

The distribution of feeder roots was found to be maximum within 10 cm depth of soil in fertigation treatments (31.5 to 37.1 g plant⁻¹) beyond this depth there was a decrease in root weight (20.3 to 23.4 g plant⁻¹) which further reduced in 20-30 cm depth of soil (3.2 to 4.5 g plant⁻¹). Similar trend was noticed in drip method also. However in traditionally irrigated and fertilized plots, the surface distribution was less (20.1 to 26.2 g plant⁻¹) in top soil layer and remained equally distributed in 10-20 cm layer (18.5 to 25.6 g plant⁻¹) and further declined beyond this depth (9.8 to 15.2 g plant⁻¹).

The 100% dose fertilizer caused higher root dry weight as compared to 80% recommended dose at all the soil depths. Response of root weight due to fertilizer sources as NF or WSF not consistent.

Root dry weight (g/plant)

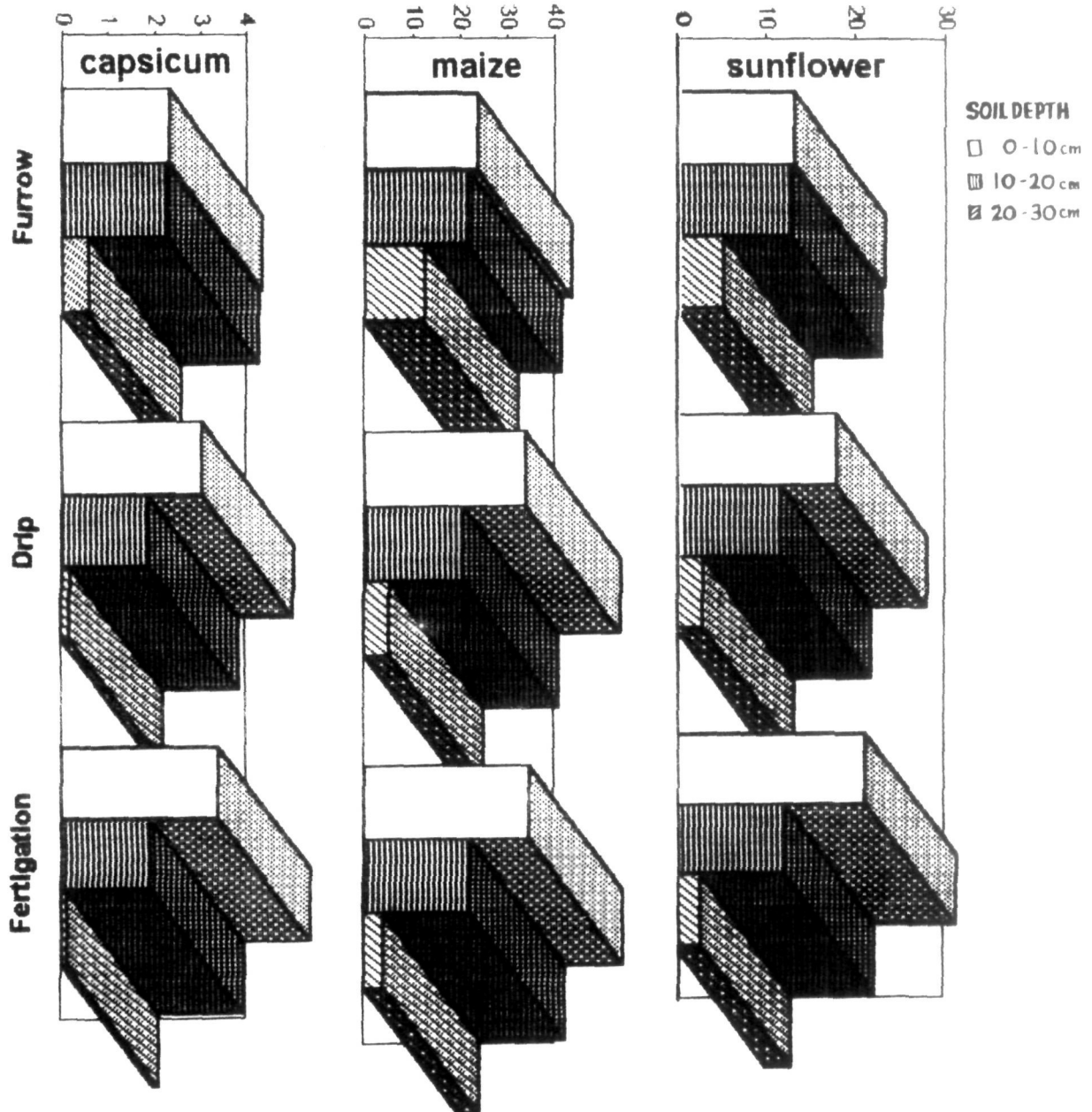

Fig. 4.19 : Root distribution pattern in capsicum, maize and sunflower as influenced by fertigation, drip and furrow irrigation (mean of two years)

In sunflower, during both 1995 and 1997, the dry weight of roots in relation to soil depth was maximum at the vicinity of the plant base and then decreased at varied points away from plant base with all the treatment combinations. However, treatments involving fertigation recorded maximum dry weight of feeder roots (19.2 to 22.2 g plant⁻¹) in top 0-10 cm soil layer as compared to drip (15.3 to 20.2 g plant⁻¹) and furrow (11.3 to 15.3 g plant⁻¹) treatments in both the years 1995 and 1997. On contrary to this at 10-20 cm soil depth the corresponding values 10.5 to 13.0 g plant⁻¹, 8.7 to 13.3 g plant⁻¹ and 10.1 to 14.4 g plant⁻¹ were almost equal suggesting a drastic reduction in root density in case of drip and fertigation treatments but same root density in furrow method in relation increasing soil depth. At deeper soil depth (20-30 cm) the trend was higher root biomass (3.9 to 5.9 g plant⁻¹) in furrow method as compared to drip (2.6-3.1 g plant⁻¹) and fertigation (2.1 to 3.2 g plant⁻¹) (Fig. 4.19).

Root dry weight in relation to soil depth due to fertilizer levels at 80% and 100% or fertilizer sources NF and WSF were not considerable. Thus, it can be inferred that fertigation favoured root distribution limited to the wetter zone where nutrients and soil moisture were in constant supply.

4.12. Residual soil nutrient status and distribution in capsicum, maize and sunflower as affected by methods of irrigation, levels and sources of fertilizers

4.12.1 Residual NO₃-N distribution in soil

The samples collected before the beginning of the experiment for initial NO₃-N at different depth of soil revealed that the initial NO₃-N was slightly more between 30-45 cm depth and negligible amount of NO₃-N was observed as the depth advanced (Table-4.43).

Table-4.43: Residual soil NO₃-N distribution after the harvest of capsicum, maize and sunflower during 1994-95 and 1996-97 as influenced by methods of irrigation, levels and sources of fertilizer

Soil depth (cm)	Residual soil NO ₃ -N (mg/kg soil)												
	1994-95												
	Initial	Furrow irrigation				Drip irrigation				Fertigation			
	80% RD	80% WSF	100% RD	100% WSF	80% RD	80% WSF	100% RD	100% WSF	80% RD	80% WSF	100% RD	100% WSF	
	After Capsicum harvest												
0-15	2.4	10.5	11.4	13.1	14.6	18.1	20.2	22.1	22.9	24.5	26.5	28.5	30.8
15-30	3.5	16.3	16.7	20.6	22.5	20.3	23.5	25.6	26.5	16.7	24.2	26.6	27.1
30-45	4.7	15.1	10.1	14.8	15.5	13.6	18.3	17.5	19.5	14.5	8.4	11.4	14.5
45-60	1.2	10.2	12.6	12.4	11.9	6.4	7.9	6.5	8.2	3.8	6.5	4.9	5.6
	After Maize harvest												
0-15	2.4	11.3	12.3	13.4	17.1	14.8	19.2	16.3	23.8	22.1	26.1	24.8	30.5
15-30	3.5	20.6	15.6	22.8	23.2	16.5	21.6	18.9	25.6	17.2	23.6	21.6	26.2
30-45	4.7	15.6	12.7	20.1	18.5	12.3	16.1	20.6	18.3	13.8	10.5	13.1	15.6
45-60	1.2	11.3	12.8	10.6	13.2	6.8	5.9	7.3	6.8	4.2	3.2	6.9	7.5
	After Sunflower harvest												
0-15	2.4	10.8	12.3	13.1	17.5	18.3	22.6	17.9	21.9	25.1	29.5	24.5	28.1
15-30	3.5	22.6	19.2	24.5	25.9	21.6	24.5	20.8	25.2	17.2	24.6	24.2	26.6
30-45	4.7	19.9	18.1	21.4	25.4	12.3	17.6	21.6	20.5	14.5	12.7	16.8	15.2
45-60	1.2	12.2	10.9	14.5	15.9	7.0	5.6	8.4	10.5	5.0	6.8	7.9	7.8
	1996-97												
	After Capsicum harvest												
0-15	2.4	12.3	13.1	13.6	18.5	17.9	21.5	18.3	22.2	24.6	26.5	26.5	30.1
15-30	3.5	24.6	20.5	26.7	27.2	20.8	24.5	23.5	26.8	20.1	22.4	25.0	29.8
30-45	4.7	18.9	21.6	2.1	21.2	16.3	19.5	19.2	21.2	15.7	10.5	16.6	18.5
45-60	1.2	13.6	15.6	16.6	14.8	8.1	6.9	10.5	9.2	6.8	7.6	7.9	7.5
	After Maize harvest												
0-15	2.4	12.5	13.2	13.9	16.5	16.5	17.9	19.3	20.5	22.5	23.5	24.6	27.1
15-30	3.5	24.6	26.5	23.2	27.9	18.5	18.6	23.5	23.9	20.6	19.5	23.5	26.8
30-45	4.7	19.7	21.8	23.4	24.5	15.9	19.2	17.9	20.6	13.7	10.5	16.6	17.2
45-60	1.2	12.7	16.9	10.5	16.6	4.9	7.5	9.5	10.5	7.2	8.9	9.8	8.2
	After Sunflower harvest												
0-15	2.4	13.1	14.5	14.9	17.3	18.9	18.3	19.6	23.6	24.5	25.6	25.8	31.8
15-30	3.5	25.7	21.5	26.2	30.1	21.3	20.5	23.6	26.7	20.7	21.7	26.1	29.9
30-45	4.7	18.3	23.6	25.1	26.8	16.9	21.2	20.3	19.8	15.6	10.2	17.2	20.1
45-60	1.2	13.4	10.8	17.2	16.2	5.8	6.5	8.1	11.2	8.2	9.8	11.0	8.7

R.D = Recommended Dose

NF = Normal Fertilizer

WSF = Water Soluble Fertilizer

The data obtained by analyzing soil samples after harvest of capsicum, maize and sunflower in both 1994-95 and 1996-97 as presented in Table-4.43 and depicted in Fig. 4.20. Indicated that out of the irrigation and fertilization methods, fertilizers applied through drip irrigation showed concentrated $\text{NO}_3\text{-N}$ distribution in effective root zone (10-30 cm) without giving much scope for leaching and hence resulted in lesser $\text{NO}_3\text{-N}$ accumulation beyond the depth of root zone. Under furrow irrigation, the residual $\text{NO}_3\text{-N}$ content in the rhizosphere of capsicum, maize and sunflower was not satisfactory as that of fertigation. However, drip irrigation with conventional fertilizer application had higher $\text{NO}_3\text{-N}$ accumulation at 15-30 cm depth than furrow irrigated plots.

In fertigated capsicum, the $\text{NO}_3\text{-N}$ level varied between 24.5 – 3.08 mg/kg soil at 0-15 cm soil depth during both the years and decreased with increasing soil depth registering 16.7-29.8 mg/kg soil, 8.4 – 14.5 mg/kg soil and 3.8 – 7.9 mg/kg soil at 15-30, 30-45 and 45-60 cm soil depths respectively during both 1994 and 1996. Full fertilizer dose (100%) and WSF source resulted in slightly higher $\text{NO}_3\text{-N}$ values than reduced dose (80%) and NF source respectively.

The drip method in capsicum had residual $\text{NO}_3\text{-N}$ to the tune of 17.9 – 22.9 mg/kg soil in the top soil layer (0-15 cm) which slightly increased to 18.5-26.5 mg/kg soil at 15-30 cm depth and then lowered to 13.6-20.6 mg/kg soil at 30-45 cm layer (Fig.4.20). The $\text{NO}_3\text{-N}$ level further reduced to 5.6-8.5 mg/kg soil in 45-60 cm soil depth thus indicating a moderate leaching of $\text{NO}_3\text{-N}$ ions because of constant water application coupled with conventional bulk fertilizer application method.

Among the individual treatments, 100% dose WSF had higher $\text{NO}_3\text{-N}$ accumulation in different soil profiles than the 80% dose NF where the $\text{NO}_3\text{-N}$ values were the lowest. The $\text{NO}_3\text{-N}$ levels in soil were relatively higher in 1996 than 1994.

In case of furrow irrigated capsicum, the $\text{NO}_3\text{-N}$ accumulation was observed in the below root zonal depths where the values 16.3 – 27.2 mg/kg soil in 15-30 cm depth and 10.1 – 24.2

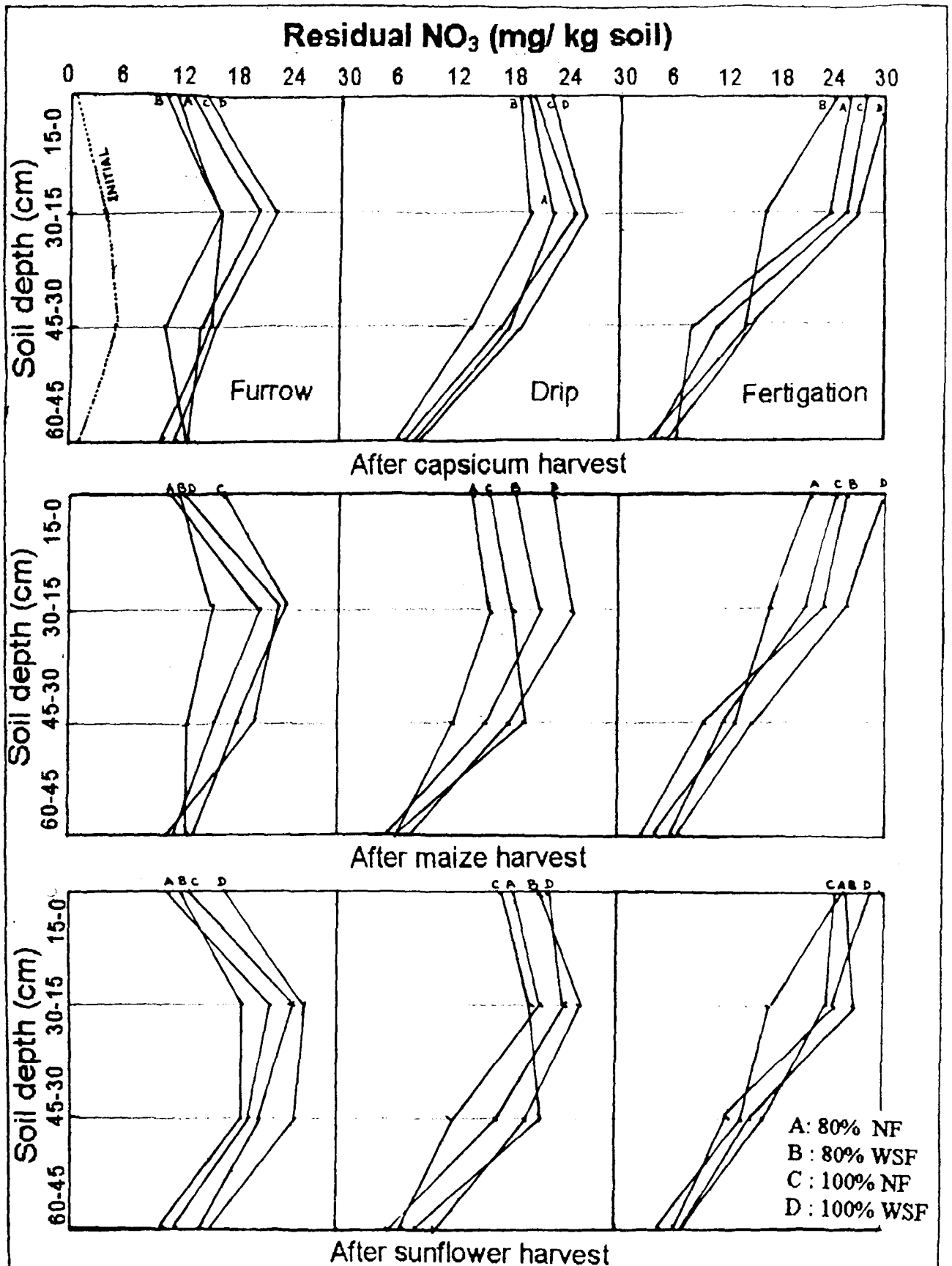

Fig. 4.20. Residual soil NO₃-N (mg/kg soil) after harvest of capsicum, maize and sunflower as influenced by fertigation, drip and furrow with levels and sources of fertilizer during 1994-95

mg/kg soil at 30-45 cm depth in both the years 1994 and 1996 were higher than 10.5 to 18.5 mg/kg soil observed in top soil layer (0-15 cm). Considerable accumulation of $\text{NO}_3\text{-N}$ (10.2-14.8 mg/kg soil) was also noticed at the deepest layer (45-60 cm) which indicated higher leaching risk of nitrates coupled with non-availability of the nutrient in effective root zone due to furrow irrigation and bulk fertilizer application as basal dose. Here also, increased fertilizer dose (100%) and water soluble fertilizer had an edge over reduced fertilizer dose (80%) and formal fertilizer by resulting in higher $\text{NO}_3\text{-N}$ accumulation as observed in fertigation or drip method.

Similar trends were observed with samples collected after maize harvest in 1994 and 1996 (Table-4.43). However, the residual $\text{NO}_3\text{-N}$ status at various soil depths remained almost same as that observed after capsicum harvest in fertigated plots but slightly increased in case of furrow method. Further, in sunflower the $\text{NO}_3\text{-N}$ distribution pattern remained same in different treatments, but greater accumulation of $\text{NO}_3\text{-N}$ (10.8 – 26.8 mg/kg soil) was detected under furrow irrigation at 15-60 cm soil depth as compared to fertigated plots (9.8 – 20.1 mg/kg soil). In case of drip irrigation relatively balanced depthwise $\text{NO}_3\text{-N}$ distribution was noticed although leaching losses were evident but not upto the extent as observed in furrow irrigation (Table-4.44) (Fig.4.20).

4.12.2 Residual phosphorus distribution in soil

The initial status of residual extractable P at different soil depth, are presented in Table-4.44 revealed that the initial soil extractable P was slightly more within 30 cm depth and beyond which the P content reduced.

The samples analyzed for extractable-P as influenced by levels and sources of fertilizer applied in furrow, drip and fertigation after the harvest of capsicum, maize and sunflower are presented in Table-4.44 and depicted in Fig. 4.21. The data indicated that accumulation of residual 'P' was satisfactory in the effective root zone when 'P' was applied through irrigation

Table-4.44: Residual soil P distribution after the harvest of capsicum maize and sunflower during 1994-95 and 1996-97 as influenced by methods of irrigation, levels and sources of fertilizer

Soil depth (cm)	Residual soil P(mg/kg soil)												
	1994-95												
	Initial	Furrow irrigation				Drip irrigation				Fertigation			
	80% RD	80% RD	100% RD	100% RD	80% RD	80% RD	100% RD	100% RD	80% RD	80% RD	100% RD	100% RD	
	NF	WSF	NF	WSF	NF	WSF	NF	WSF	NF	WSF	NF	WSF	
	After Capsicum harvest												
0-15	3.1	8.2	10.3	12.6	16.5	5.5	7.5	10.6	11.3	5.7	9.3	8.4	12.3
15-30	4.2	3.5	3.6	2.5	4.7	3.2	2.7	3.7	5.2	3.1	4.6	4.5	5.0
30-45	2.7	2.6	2.5	3.0	4.5	2.5	2.2	3.2	2.5	2.8	4.1	4.2	2.6
45-60	2.1	2.1	2.0	2.1	1.8	1.9	1.8	2.2	2.1	2.1	2.5	2.0	2.0
	After Maize harvest												
0-15	3.1	9.6	10.9	13.1	14.9	7.0	6.5	10.0	11.0	6.9	9.3	9.8	12.5
15-30	4.2	3.8	2.7	3.6	5.2	2.3	3.7	3.8	4.0	4.7	3.2	6.3	4.3
30-45	2.7	2.5	3.1	1.6	2.5	2.4	2.3	2.6	3.1	2.8	1.9	3.5	2.5
45-60	2.1	2.6	1.8	2.5	3.1	2.0	2.0	1.7	2.6	2.1	3.2	1.6	3.2
	After Sunflower harvest												
0-15	3.1	10.5	11.8	12.9	18.5	8.6	8.9	11.5	12.5	8.4	9.6	10.4	13.8
15-30	4.2	4.6	3.9	3.8	5.6	3.7	2.6	3.5	4.7	3.1	2.9	2.8	4.7
30-45	2.7	2.5	2.6	3.7	5.0	2.5	1.5	2.1	3.8	2.7	2.5	2.3	2.0
45-60	2.1	2.1	1.9	1.7	4.1	1.7	1.2	2.0	3.0	2.0	1.7	1.9	2.5
	1996-97												
	After Capsicum harvest												
0-15	3.1	10.3	12.8	13.9	17.9	10.2	8.9	12.6	13.2	10.6	9.8	10.5	15.6
15-30	4.2	4.6	5.1	5.8	4.8	3.9	3.8	4.5	2.8	3.5	3.5	5.6	6.1
30-45	2.7	2.2	2.7	3.5	2.7	2.5	2.9	3.1	2.5	2.4	2.6	4.7	3.8
45-60	2.1	2.0	1.9	4.2	3.5	2.0	1.9	1.9	3.0	2.2	2.5	2.2	3.0
	After Maize harvest												
0-15	3.1	9.2	11.3	12.5	14.7	11.3	8.7	10.6	13.9	11.2	9.2	10.9	15.0
15-30	4.2	4.4	4.6	4.4	5.6	3.6	4.2	4.7	5.2	3.2	3.0	3.1	4.3
30-45	2.7	2.2	2.7	3.1	2.8	2.6	3.8	3.2	2.1	2.5	2.5	2.0	3.0
45-60	2.1	2.1	1.8	1.6	3.2	2.0	1.9	2.2	3.0	3.1	1.6	2.1	3.1
	After Sunflower harvest												
0-15	3.1	10.7	14.2	16.8	16.7	12.5	9.8	11.3	15.5	12.7	9.6	10.2	13.9
15-30	4.2	4.9	4.5	5.4	4.8	3.6	4.6	4.3	5.2	3.8	3.5	6.2	4.5
30-45	2.7	3.5	2.0	3.5	4.3	2.1	3.1	2.8	2.9	3.0	2.5	5.3	4.3
45-60	2.1	2.1	3.2	2.4	2.7	2.0	2.2	1.9	2.0	2.9	1.0	2.7	2.6

R.D = Recommended Dose

NF = Normal Fertilizer

WSF = Water Soluble Fertilizer

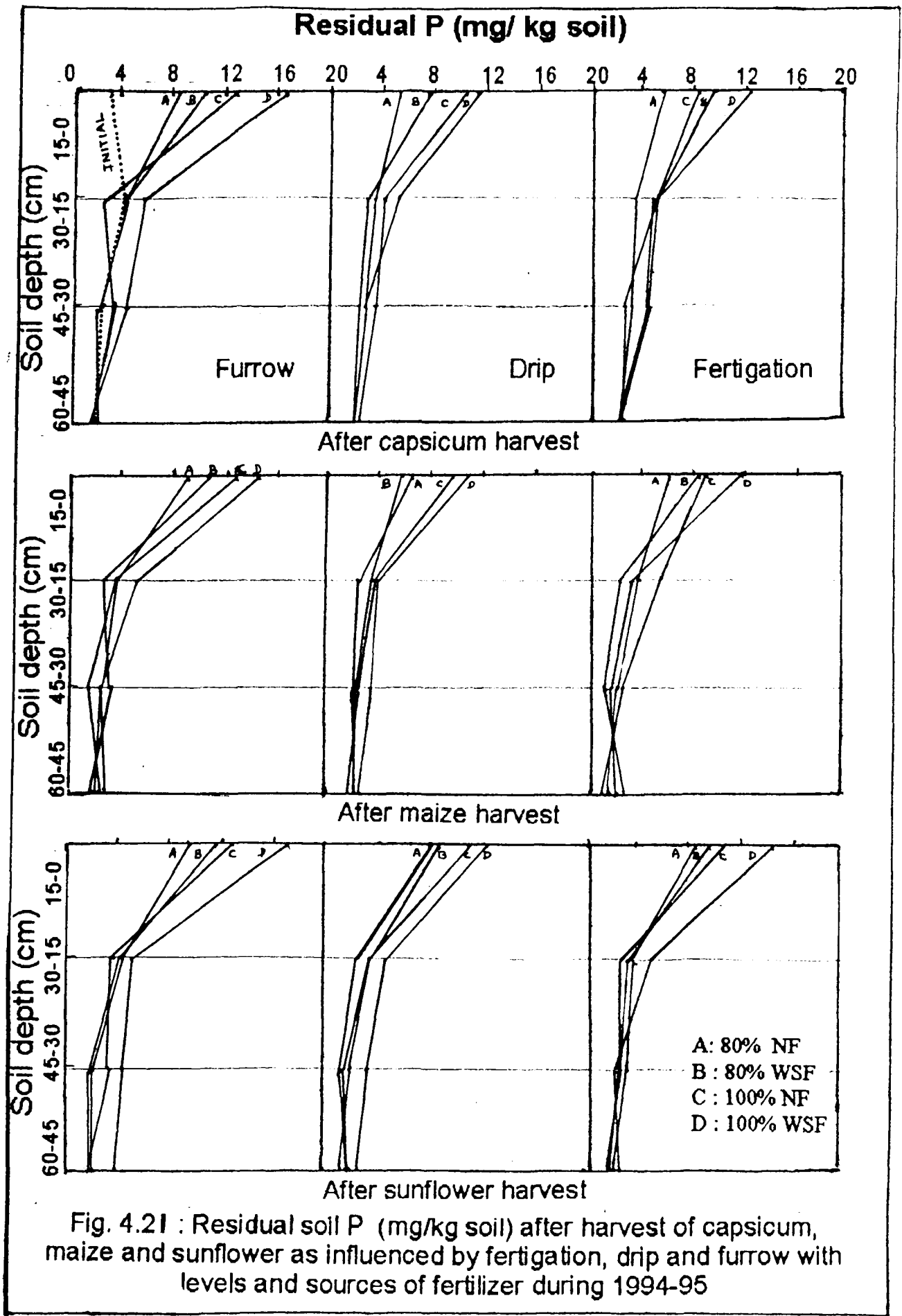

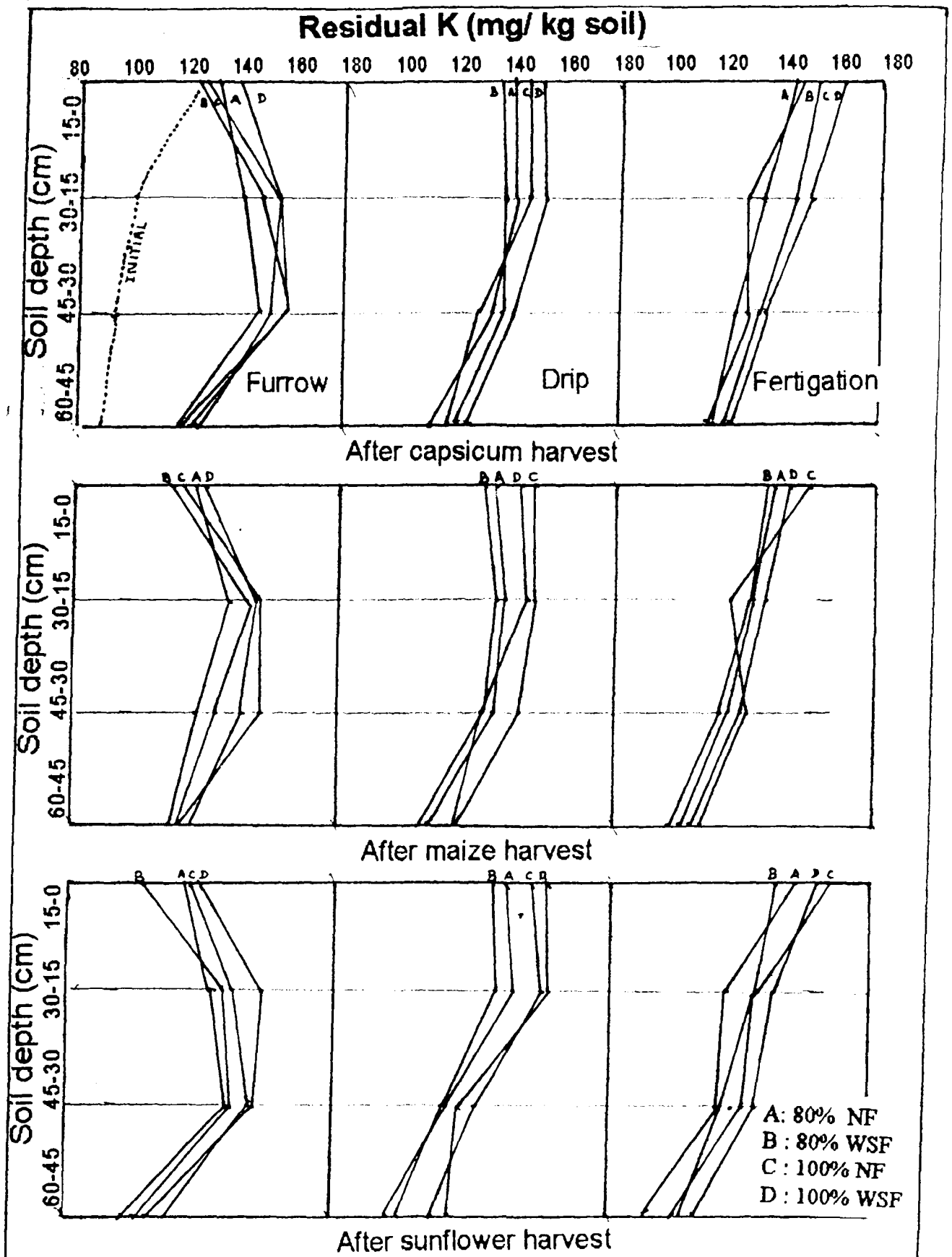

Fig. 4.22 : Residual soil K (mg/kg soil) after harvest of capsicum, maize and sunflower as influenced by fertigation, drip and furrow with levels and sources of fertilizer during 1994-95

which also resulted in accumulation of 'P' below root zonal depth as compared to non fertigated plots. However, at 0-15 cm soil depth the residual P accumulation was slightly more under furrow irrigation (9.2 to 18.5 mg/kg soil) as compared to drip (5.5 to 15.5 mg/kg soil) or fertigation (5.7 to 15.6 mg/kg soil) in all the three crops but at the later depths (15-45 cm) of effective root zone fertigated plots had more 'P' accumulation (1.9 to 6.2 mg/kg soil) than furrow irrigation (1.6-5.8 mg/kg soil). Residual P distribution under the influence of drip irrigation was not much different from fertigation treatment.

Between the levels of fertilizer, 100% recommended dose resulted in higher P accumulation at all soil depths than the 80% recommended dose. Similarly, water soluble source caused higher P accumulation than the normal fertilizer.

As an interaction effect, 100% dose WSF application in furrow caused for considerable accumulation of P below root zonal depths (5.6-2.7 mg/kg soil) as compared to same treatment in fertigated plots (5.0-2.0 mg/kg soil) except at 15-30 cm in maize during 1996 where the residual P level was 6.1 mg/kg soil.

The data obtained for the year 1996-97 was slightly higher than 1994-95 in all the treatments. The P distribution pattern did not differ much among capsicum, maize or sunflower but the residual P level increased gradually over the cropping sequences.

4.12.3 Residual exchangeable-K distribution in soil

Data collected by analyzing soil samples for exchangeable K at different soil depths revealed that initial exchangeable K was more (1.25 mg/kg soil) in top soil layer and then reduced into deeper layers.

The soil samples analyzed for exchangeable-K as influenced by levels and sources of fertilizer applied in irrigation water and localized placement of the harvest of each crop are

presented in Table-4.45 and depicted in Fig.4.22. The data implies that the residual K was higher in the effective root zone with fertigated plots and also resulted in lesser accumulation of K at beyond root zonal depth and hence less leaching as compared to non-fertigated plots. Drip method with direct soil application of fertilizer also maintained satisfactory K level at 0-30 cm soil depth but the highest K accumulation was observed in 15-30 cm depth than the top 0-15 cm layer.

Full dose (100%) resulted in higher K accumulation than the reduced dose (80%) irrespective of method of application. Similarly water soluble fertilizer increased residual K level than the normal fertilizer at all soil depths in both the years.

In fertigated capsicum, the exchangeable-K level varied between 141.2-161.2 mg/kg soil at 0-15 cm soil depth during both the years and decreased with deeper soil profiles registering 128.2-151.0 mg/kg soil, 121.1-134.6 mg/kg soil and 110.2-129.2 mg/kg soil at 15-30, 30-45 and 45-60 cm soil depths respectively during both 1994 and 1996. Whereas, the drip method had residual K to the tune of 133.2-164.5 mg/kg soil in the top soil layer (0-15 cm) which slightly increased to 136.8 —163.6 mg/kg soil at 15-30 cm and then decreased to 121.6-144.2 mg/kg soil in 30-45 soil depth. The exchangeable-K further reduced to 102.0-125.5 mg/kg soil in 45-60 cm soil depth thus indicating moderate leaching of K because of continuous water movement under drip coupled with conventional bulk fertilizer application.

Generally, the 100% dose WSF had the highest K accumulation in different soil profiles and the least values were associated with 80% dose NF. The residual K in soil was relatively higher in 1996-97 than in 1994-95.

In case of furrow irrigated capsicum, concentrated exchangeable K accumulation was found at sub surface (15-45 cm) where the values 140.5-152.7 mg/kg soil in 15-30 cm depth and 140.2-159.0 mg/kg soil in 30-45 cm depth were higher than 122.6-135.6 mg K/kg soil observed in surface layer (0-15 cm). The K distribution patten under furrow irrigation indicated higher leaching

Table-4.45: Residual soil K distribution after the harvest of capsicum maize and sunflower during 1994-95 and 1996-97 as influenced by methods of irrigation, levels and sources of fertilizer

Soil depth (cm)	Residual soil K (mg/kg soil)												
	1994-95												
	Initial	Furrow irrigation				Drip irrigation				Fertigation			
	80%	80%	100%	100%	80%	80%	100%	100%	80%	80%	100%	100%	
	RD	RD	RD	RD	RD	RD	RD	RD	RD	RD	RD	RD	
	NF	WSF	NF	WSF	NF	WSF	NF	WSF	NF	WSF	NF	WSF	
After Capsicum harvest													
0-15	125	131.6	124.6	128.1	129.8	140.3	135.8	143.8	151.5	148.3	145.7	152.5	159.5
15-30	99	140.5	148.7	152.7	151.2	143.5	138.6	141.6	153.2	131.2	128.2	147.6	151.0
30-45	95	145.6	146.0	151.0	150.1	134.7	136.3	127.6	141.5	123.1	125.0	130.5	131.2
45-60	88	119.2	118.8	121.2	124.6	110.5	120.1	118.0	125.5	113.8	117.0	118.2	120.2
After Maize harvest													
0-15	125	128.2	118.2	119.6	131.2	138.8	133.5	153.2	145.9	145.8	141.8	160.2	153.6
15-30	99	131.6	141.2	150.2	148.6	139.6	136.7	150.6	149.5	132.6	132.2	125.0	138.5
30-45	95	128.1	135.1	152.6	145.6	114.5	125.7	143.6	131.2	120.7	123.6	132.0	129.0
45-60	88	118.1	119.2	119.2	128.0	108.0	107.2	119.5	120.0	102.0	107.5	113.7	107.8
After Sunflower harvest													
0-15	125	122.6	107.3	125.1	127.1	143.2	135.6	154.8	155.8	150.5	143.5	162.3	160.3
15-30	99	138.2	139.2	141.6	152.2	146.5	137.8	156.5	157.6	127.6	135.6	135.0	142.2
30-45	95	140.2	140.6	148.2	142.6	120.3	119.6	132.4	125.3	122.3	123.2	132.8	135.6
45-60	88	102.6	99.6	116.6	104.6	98.2	102.1	115.2	121.8	112.0	97.5	108.0	112.8
1996-97													
After Capsicum harvest													
0-15	125	129.1	122.6	129.2	135.6	151.2	133.2	157.6	164.5	159.3	141.2	165.8	161.2
15-30	99	141.2	138.2	149.0	152.7	153.5	136.8	159.5	166.6	132.0	129.5	140.8	149.8
30-45	95	148.8	140.2	151.2	159.0	144.3	121.6	136.8	142.2	125.0	125.0	132.0	134.6
45-60	88	112.6	117.2	120.0	122.1	120.1	102.6	112.0	125.0	119.6	110.2	129.2	121.1
After Maize harvest													
0-15	125	131.1	120.1	128.1	139.2	157.5	142.6	153.5	156.8	161.5	148.5	160.0	165.3
15-30	99	146.6	131.2	137.1	147.5	160.3	143.5	154.6	155.3	130.2	123.6	132.1	150.2
30-45	95	149.2	135.6	163.0	161.5	133.5	126.8	139.5	140.2	123.7	127.8	130.8	135.5
45-60	88	113.8	115.3	121.2	123.8	103.5	108.9	120.2	123.0	112.0	102.5	115.3	116.0
After Sunflower harvest													
0-15	125	132.2	127.2	139.2	141.7	155.6	146.3	166.5	161.6	165.2	151.8	172.6	169.5
15-30	99	148.5	139.0	147.5	160.6	154.6	143.8	164.8	163.7	158.0	120.6	157.0	145.3
30-45	95	143.1	171.2	165.8	165.9	144.6	148.9	151.6	149.3	121.5	125.9	138.6	132.7
45-60	88	110.8	128.1	127.2	128.8	113.8	112.2	119.5	125.6	110.5	112.8	115.5	122.5

RD = Recommended Dose

NF = Normal Fertilizer

WSF = Water Soluble Fertilizer

risk of K into deeper layers coupled with non-availability of sufficient nutrient in the effective root zone.

Similar trends were observed with samples collected after maize and sunflower harvest in 1994-95 and 1996-97 (Table-4.15). However, the residual exchangeable K status gradually increased over the cropping sequence. Leaching losses were also evident with the use of drip irrigation as the residual K level was slightly higher than fertigated plots in 30-60 cm soil depth.

4.13 Economics of fertigation in capsicum, maize and sunflower

Economics pertaining to levels and sources of fertilizer applied in fertigation, drip and furrow methods during I sequence are presented in Table-4.46. The cost of equipment, 35,000 Rs./ha was spread over for an estimated life span of 10 years for 3 crops a year included interest on investment and share of depreciation at 10% per annum. The cost of normal and water soluble fertilizer were taken at the existing rates. The cultivation cost included the cost of all other inputs except fertilizers.

Among the methods of water and fertilizer application methods, fertigation method resulted in higher gross and net returns and hence maximum Cost : Benefit ratio of 4.18, 2.10 and 1.59 in capsicum, maize and sunflower respectively followed by drip method (3.81, 1.85 and 1.34 correspondingly). The C : B ratio of 3.47, 1.85 and 1.28 correspondingly obtained with furrow method was lower than the former treatments.

Among different treatment combinations although the highest gross returns were registered in all three crops (85,509, 24,688 and 19,562 Rs.) with the use of 100% dose WSF in

Table 4.46 : Economic analysis of fertigation in capsicum-maize-sunflower cropping sequence in 1994-95

Treatments	Fixed cost	Fertilizer cost	Cost of cultivation	Total cost Rs./ha	Gross* returns	Net returns	C.B. Ratio
				Capsicum			
Furrow irrigation							
T ₁ :80% R.D. NF	-	2265	11970	14235	67707	55472	3.75
T ₂ :80% R.D. WSF	-	8161	11970	20131	67347	47216	2.34
T ₃ :100% R.D. NF	-	2830	11970	14800	70614	55814	3.77
T ₄ :100% R.D. WSF	-	10202	11970	22172	69570	47398	2.14
Mean							3.00
Drip Irrigation							
T ₅ : 80% R.D. NF	1440	2265	11500	15205	76509	61304	4.03
T ₆ :80% R.D. WSF	1440	8161	11500	21101	75888	54787	2.60
T ₇ :100% R.D. NF	1440	2830	11500	15770	79443	63673	4.04
T ₈ :100% R.D. WSF	1440	10202	11500	23142	78876	55734	2.41
Mean							3.27
Fertigation							
T ₉ : 80% R.D. NF	1440	2265	11200	14905	83205	68300	4.58
T ₁₀ :80% R.D. WSF	1440	8161	11050	20651	84438	63787	3.09
T ₁₁ :100% R.D. NF	1440	2830	11200	15470	84960	69490	4.49
T ₁₂ :100% R.D. WSF	1440	10202	11050	22692	83509	62817	2.77
Mean							3.73
				Maize			
Furrow irrigation							
T ₁ :80% R.D. NF	-	2265	3400	5665	20985	15230	2.68
T ₂ :80% R.D. WSF	-	8161	3400	11561	20842	9281	0.80
T ₃ :100% R.D. NF	-	2830	3400	6230	21685	15455	2.48
T ₄ :100% R.D. WSF	-	10202	3400	13602	21782	8180	0.60
Mean							1.64
Drip Irrigation							
T ₅ : 80% R.D. NF	1440	2265	2400	6105	22380	16275	2.67
T ₆ :80% R.D. WSF	1440	8161	2400	12001	22537	10536	0.88
T ₇ :100% R.D. NF	1440	2830	2400	6670	23547	10877	2.53
T ₈ :100% R.D. WSF	1440	10202	2400	14042	23161	9119	0.65
Mean							1.68
Fertigation							
T ₉ : 80% R.D. NF	1440	2265	2100	5805	24052	18247	3.14
T ₁₀ :80% R.D. WSF	1440	8161	1950	11551	23811	12260	1.06
T ₁₁ :100% R.D. NF	1440	2830	2100	6370	24357	17987	2.82
T ₁₂ :100% R.D. WSF	1440	10202	1950	13592	24688	11096	0.82
Mean							1.96
				Sunflower			
Furrow irrigation							
T ₁ :80% R.D. NF	-	1825	2980	4805	15306	10501	2.18
T ₂ :80% R.D. WSF	-	5717	2980	8697	14478	5781	0.66
T ₃ :100% R.D. NF	-	2281	2980	5261	16468	11207	2.13
T ₄ :100% R.D. WSF	-	7147	2980	10127	16100	5973	0.58
Mean							1.39
Drip Irrigation							
T ₅ : 80% R.D. NF	1440	1825	2000	5265	16640	11375	2.16
T ₆ :80% R.D. WSF	1440	5717	2000	9157	17192	8035	0.88
T ₇ :100% R.D. NF	1440	2281	2000	5721	18457	12736	2.23
T ₈ :100% R.D. WSF	1440	7147	2000	10587	17549	6962	0.66
Mean							1.48
Fertigation							
T ₉ : 80% R.D. NF	1440	1825	1750	5015	1833	13316	2.66
T ₁₀ :80% R.D. WSF	1440	5717	1600	8757	17917	9160	1.05
T ₁₁ :100% R.D. NF	1440	2281	1750	5471	18780	13309	2.43
T ₁₂ :100% R.D. WSF	1440	7147	1600	10187	19562	9375	0.92
Mean							1.77

*Price of capsicum Rs.9.00/kg, Maize Grain Rs.4.80/kg, Stover Rs.250/tonne.

Sunflower seeds Rs.11.50/kg

R.D = Recommended Dose

NF = Normal Fertilizer

WSF = Water Soluble Fertilizer

fertigation, maximum net returns were obtained with fertigated 100% dose NF in capsicum (69,490 Rs.) and 80% dose NF in both maize (18,247 Rs.) and sunflower (13,316 Rs.). Use of 100% dose WSF in furrow irrigation resulted in lower net returns (47,398, 8,180 and 5,973 Rs. respectively) and hence the lowest C : B ratio (2.14, 0.60 and 0.58 respectively) in all these crops.

Economics of second capsicum-maize-sunflower cropping sequence also followed the similar trend as in the first sequence. However, the gross, net and C : B ration were higher in maize but decreased in case of capsicum and sunflower as compared to the previous sequence (Table-4.47) (Fig. 4.23).

Combined cost economics for 3 crops in a sequence and for 6 crops in two sequences indicated that fertigation method enhanced the C : B ratio by 0.54 Rs. and 0.51 Rs. in 1994-95 and 1996-97 respectively from 2.32 Rs. and 2.59 Rs. obtained under furrow irrigation method correspondingly (Table-4.48). At the end of the experiment, an increase of 0.53 Rs. was registered by fertigation treatments over C : B ratio of 2.46 Rs. obtained with furrow treatments.

Among different treatment combinations, the net return was the highest (2,09318 Rs./ha) with 100% dose NF supplied through fertigation. However, the C : B ratio (4.04) observed with 80% dose NF under fertigation was the highest than rest of the treatments. The net return (1,31,452 Rs./ha as well as C : B ratio (1.43) were the least when 100% dose WSF was furrow applied (Table-4.48).

Table 4.47 : Economic analysis of fertigation in capsicum-maize-sunflower cropping sequence in 1996-97

Treatments	Fixed cost	Fertilizer cost	Cost of cultivation	Total cost Rs./ha	Gross* returns	Net returns	C/B Ratio
<u>Capsicum</u>							
<u>Furrow irrigation</u>							
T ₁ :80% R.D. NF	-	2265	11970	14235	76410	62175	4.36
T ₂ :80% R.D. WSF	-	8161	11970	20131	75180	55049	2.73
T ₃ :100% R.D. NF	-	2830	11970	14800	78600	63800	4.31
T ₄ :100% R.D. WSF	-	10202	11970	22172	77650	55478	2.50
Mean							3.47
<u>Drip Irrigation</u>							
T ₅ : 80% R.D. NF	1440	2265	11500	15205	86670	71465	4.70
T ₆ :80% R.D. WSF	1440	8161	11500	21101	86050	64949	3.08
T ₇ :100% R.D. NF	1440	2830	11500	15770	88250	72480	4.60
T ₈ :100% R.D. WSF	1440	10202	11500	23142	89190	66048	2.85
Mean							3.81
<u>Fertigation</u>							
T ₉ : 80% R.D. NF	1440	2265	11200	14905	91750	76665	5.14
T ₁₀ :80% R.D. WSF	1440	8161	11050	20651	90660	70009	3.39
T ₁₁ :100% R.D. NF	1440	2830	11200	15470	92840	77370	5.00
T ₁₂ :100% R.D. WSF	1440	10202	11050	22692	95050	72358	3.19
Mean							4.18
<u>Maize</u>							
<u>Furrow irrigation</u>							
T ₁ :80% R.D. NF	-	2265	3400	5665	22870	17205	3.04
T ₂ :80% R.D. WSF	-	8161	3400	11561	22727	11166	0.96
T ₃ :100% R.D. NF	-	2830	3400	6230	23334	17104	2.74
T ₄ :100% R.D. WSF	-	10202	3400	13602	22972	9370	0.69
Mean							1.85
<u>Drip Irrigation</u>							
T ₅ : 80% R.D. NF	1440	2265	2400	6105	23914	17809	2.92
T ₆ :80% R.D. WSF	1440	8161	2400	12001	23942	11941	1.00
T ₇ :100% R.D. NF	1440	2830	2400	6670	24702	18032	2.70
T ₈ :100% R.D. WSF	1440	10202	2400	14042	25052	11010	0.79
Mean							1.85
<u>Fertigation</u>							
T ₉ : 80% R.D. NF	1440	2265	2100	5805	25043	19238	3.31
T ₁₀ :80% R.D. WSF	1440	8161	1950	11551	25337	13786	1.19
T ₁₁ :100% R.D. NF	1440	2830	2100	6370	25597	19227	3.02
T ₁₂ :100% R.D. WSF	1440	10202	1950	13592	25845	12253	0.90
Mean							2.10
<u>Sunflower</u>							
<u>Furrow irrigation</u>							
T ₁ :80% R.D. NF	-	1825	2980	4805	14124	9319	1.93
T ₂ :80% R.D. WSF	-	5717	2980	8697	14652	5955	0.68
T ₃ :100% R.D. NF	-	2281	2980	5261	15924	10663	2.02
T ₄ :100% R.D. WSF	-	7147	2980	10127	15180	5053	0.50
Mean							1.28
<u>Drip Irrigation</u>							
T ₅ : 80% R.D. NF	1440	1825	2000	5265	16212	10947	2.08
T ₆ :80% R.D. WSF	1440	5717	2000	9157	15552	6395	0.70
T ₇ :100% R.D. NF	1440	2281	2000	5721	16728	11007	1.92
T ₈ :100% R.D. WSF	1440	7147	2000	10587	17532	6945	0.66
Mean							1.34
<u>Fertigation</u>							
T ₉ : 80% R.D. NF	1440	1825	1750	5015	16860	11845	2.36
T ₁₀ :80% R.D. WSF	1440	5717	1600	8757	17616	8859	1.02
T ₁₁ :100% R.D. NF	1440	2281	1750	5471	17496	12025	2.20
T ₁₂ :100% R.D. WSF	1440	7147	1600	10187	18180	7993	0.78
Mean							1.59

*Price of capsicum Rs. 10/kg, Maize Grain-Rs 5.10/kg, Stover-Rs. 250/tonne. Sunflower seeds Rs 12/kg
R.D. = Recommended Dose NF = Normal Fertilizer WSF = Water Soluble Fertilizer

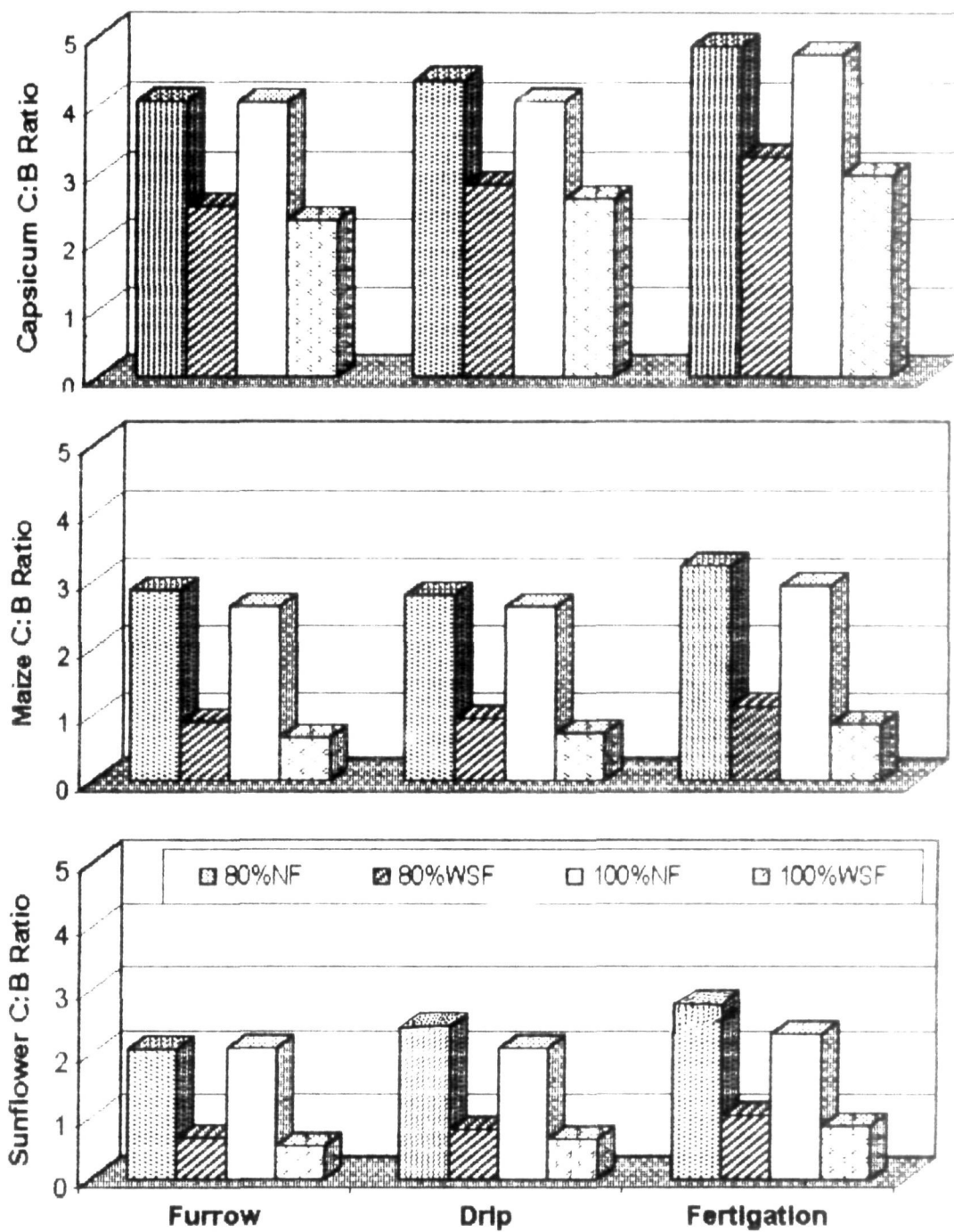

Fig 4.23 :Cost : Benefit ratio in capsicum, maize and sunflower as influenced by fertigation, drip and furrow and drip with levels and sources of fertilizer (mean of two years)

Table-4.48 : Economic analysis of fertigation in Capsicum-maize-sunflower cropping sequence in 1994-95 and 1996-97

Treatments	1994-95			1996-97			1994-97		
	Total cost Rs/ha	Total Net returns Rs/ha	C.B. Ratio	Total cost Rs/ha	Total Net returns Rs/ha	C.B. Ratio	Total cost Rs/ha	Total Net returns Rs/ha	C.B. Ratio
Furrow irrigation									
T ₁ :80% R.D. NF	24705	81203	3.29	24705	88699	3.59	49410	169902	3.43
T ₂ :80% R.D. WSF	40389	62278	1.54	40389	72170	1.79	80778	134448	1.66
T ₃ :100% R.D. NF	26291	82476	3.13	26291	91567	3.48	52582	174043	3.31
T ₄ :100% R.D. WSF	45901	61551	1.34	45901	69901	1.52	91802	131452	1.43
Mean			2.32			2.59			2.46
Drip Irrigation									
T ₅ : 80% R.D. NF	26575	88954	3.35	26575	100221	3.77	53150	189173	3.56
T ₆ :80% R.D. WSF	42259	73358	1.74	42259	83285	1.97	84518	156643	1.86
T ₇ :100% R.D. NF	28161	93286	3.31	28161	101519	3.61	56322	194805	3.46
T ₈ :100% R.D. WSF	47771	71815	1.51	47771	84003	1.76	95542	155818	1.63
Mean			2.48			2.78			2.63
Fertigation									
T ₉ : 80% R.D. NF	25725	99863	3.89	25725	107748	4.19	51450	207611	4.04
T ₁₀ :80% R.D. WSF	40959	85207	2.08	40959	92654	2.26	81918	177861	2.17
T ₁₁ :100% R.D. NF	27311	100696	3.69	27311	108622	3.98	54622	209318	3.83
T ₁₂ :100% R.D. WSF	46471	83288	1.79	46471	92604	1.99	92942	175892	1.89
Mean			2.86			3.10			2.98

DISCUSSION

V. DISCUSSION

The results presented in the previous chapter on the “Effect of fertigation with normal and water soluble fertilizers on capsicum-maize-sunflower cropping sequence” are discussed here in this chapter.

Soil moisture and plant nutrients are essential inputs required for high productivity of crops. In most situations, these requirements are not optimally met under farmers method resulting in poorer yields. Conventionally, flat bed and furrow methods of irrigation are widely followed which result in low WUE also. Coupled with such inefficient methods of irrigation, the fertilizer doses are also not optimized and their use efficiencies are very low. Therefore, a synergistic effect of simultaneously supplying water and fertilizers in small and frequent dose is expected to enhance their effective use. These are assured in the recent years through drip irrigation or fertigation.

In the current experiment, it was envisaged to raise the crops in a sequence so that the cost of cultivation could be considerably reduced by adopting a thorough cultivation of the first crop only and installing chapins in crop rows and raising the subsequent five crops with only loosening the soil between the crop rows at the beginning of each sowing/planting, thus curtailing the preparatory cultivation practices of ploughing, leveling, marking and formation of ridges and furrows. To achieve these, a common spacing of 60 cm x 30 cm was adopted for all the crops in the sequence and a chapin drip system was introduced at the beginning of the first crop which remained intact till the end of the experiment after the sixth crop. However, at the beginning of each crop small replacements of chapins to the tune of 10% was necessiated because of damage caused through cultural operations. A light flushing of the whole system was undertaken at the end of each crop to clear away any possible blockages of fertilizers in the outlets by adding weak acids in irrigation water. Precautions were taken especially in the kharif season to provide furrow irrigation or drip-cum-fertigation only in fair weather by slightly modifying the schedules by 1-3 days

An examination of the growth yield and quality aspects of capsicum, maize and sunflower under varied treatment combinations indicated significant differences among themselves in all the three crops during both the years 1994-95 and 1996-97. In general, the growth and development of maize and sunflower were excellent resulting in superior yields. However, capsicum suffered relatively more due to pest and disease problems inspite of proper execution of recommended plant protection procedures. There was no paucity of moisture or nutrients since the crops were irrigated either through drip or furrow method. The weather conditions particularly rainfall did not affect the fertigation practice even in the kharif seasons.

3.1 Soil moisture distribution pattern and irrigation water use efficiency of capsicum, maize and sunflower as influenced by methods of irrigation, levels and sources of fertilizer

The soil moisture data revealed that at the top 0-30 cm soil profile, both drip and fertigation treatments had more soil moisture content (28.2-24.3%) upto 20 cm radial distance from the crop row. Thus, there was adequate availability of moisture in the active root zone of these crops. The same moisture regime slightly above field capacity was maintained throughout crop growth period by daily operation of drips with the water quantity equal to previous days open pan evaporation. In contrast, in the furrow method, the top 0-30 cm soil layer had lower soil moisture content (17.8-22.2%) upto 30 cm horizontal distance from crop row as compared to drip or fertigation systems. This soil moisture regime was not maintained constantly due to cyclic nature of furrow irrigation of weekly intervals. Thus, though initially the moisture percentage was near the field capacity, with each passing day, the moisture was depleted and was nearing wilting point by 4th or 5th day itself. However, the below 30 cm soil layer contained higher moisture per cent (23.2 – 26.4%) which was not easily within the reach of the roots. This percolated water along with moisture between 20-30 cm horizontal distance from the crop row was thus unavailable for plant use. Further, greater fluctuations in soil water content at different strata between the weekly irrigation cycles resulted in reduced water availability as against constant moisture supply characteristic to drip or fertigation

system. These results are in conformity with the work of Goldberg and Shmueli (1970) who observed that the soil moisture content under drip irrigation was constantly between saturation and field capacity while in the furrow method of irrigation soil moisture ranged from field capacity to wilting point. In this context Bucks *et al.* (1981) also reported that drip system wets 33 to 66 per cent of root volume for better performance of tomato.

Thus, in the drip irrigation, since the water was given only around the root zone of the crop, the uptake of water per unit weight and per unit length of roots in the wetted portion increased as also reported by Haynes (1985). The wetted area led to less loss of moisture through evaporation as compared to the conventional method of furrow irrigation.

In the current experiment, low moisture loss and daily irrigation in drip method increased the availability of water which in turn caused higher irrigation water use efficiency in capsicum (1.86 – 2.34 kg M⁻¹), maize (1.21-1.35 kg M⁻¹) and sunflower (0.25-0.29 kg M⁻¹) in both fertigation and drip irrigation treatments over the furrow method where the corresponding values were lower than drip/fertigation. Thus, these effected a higher efficiency of drip/ferti system by 50-49% in capsicum, 43-41% in maize and 55-44% in sunflower. These results are in agreement with the findings of Ben-Asher *et al.* (1978) wherein he stated that ferti-drip irrigation serves better with increasing WUE to an extent of 30 per cent in tomato crop over traditional method. In the current study, nearly 21-23% of water saving was noticed with drip/fertigated plots as compared to furrow method (Table-3.5).

5.2 Status and nutrient distribution pattern, nutrient uptake and fertilizer use efficiency as influenced by fertigation and non-fertigation in capsicum, maize and sunflower.

5.2.1 Nutrient distribution pattern

The distribution of residual NO₃-N was confined to the effective root zone (0-30 cm) in fertigation (31.8-16.7 mg/kg soil) without giving much scope for leaching. Thus, lower NO₃-N

accumulation was observed beyond the depth of root zone. Whereas in the soil applied plots but with drip irrigation relatively lower $\text{NO}_3\text{-N}$ level at top (0-15 cm) layer (23.6-14.8 mg/kg soil) was observed which slightly increased in the 15-30 cm zone (26.7-16.5) along with the wetting front. However, considerable $\text{NO}_3\text{-N}$ concentration was also noticed below root zonal depths (30-60 cm). This was as a result of application of fertilizers to soil in two doses of basal and top dressing only compared to biweekly application of fertilizers through drip system in the fertigation treatments.

In case of furrow method most of the soil $\text{NO}_3\text{-N}$ content was distributed below root zonal depths (30.1 – 10.8 mg/kg soil) and hence the $\text{NO}_3\text{-N}$ level within the rhizosphere of capsicum, maize and sunflower was not satisfactory (10.5-18.5 mg/kg soil). Full fertilizer dose (100%) and WSF source resulted in slightly higher soil $\text{NO}_3\text{-N}$ content than reduced dose (80%) and NF source respectively (Table-4.44).

Relatively smaller doses of fertilizer with increased frequency of application in fertigation resulted in lower accumulation of $\text{NO}_3\text{-N}$ after capsicum (18.5-3.8 mg/kg soil), maize (16.6-3.2 mg/kg soil) and sunflower (20.1-5.0 mg/kg soil) below root zonal depth as compared to drip irrigated plots (21.2-6.4, 20.6-4.8 and 21.2-5.8 mg/kg soil) correspondingly or furrow irrigated plots (24.2-10.2, 24.5-10.5 and 26.8-10.9 mg/kg soil respectively). The increased leaching losses in furrow method was due to conventional bulk application of fertilizer coupled with high quantity of water applied in weekly intervals. In contrast, under drip method, leaching losses were not so severe but the $\text{NO}_3\text{-N}$ ions were found to have moved into deeper soil layers because of bulk soil applied fertilizer subjected to daily water application. These results are in agreement with the findings of Papadopoulos (1985 and 1988).

The P accumulation was satisfactory in the top soil when it was fertigated (15.6-5.7 mg/kg soil) and also at 15-30 cm soil depth (6.3-2.8 mg/kg soil) which further decreased with decrease in soil depth. However, the residual P level was slightly more under furrow irrigation at

top soil layer (18.5 –8.2 mg/kg soil) as compared to both drip and fertigation methods. At the lower soil depths (15-60 cm) fertigation had slightly more P accumulation (6.2-1.9 mg/kg soil) than furrow method (5.8-1.6 mg/kg soil). Thus, it implies that there exists a scope for P leaching in all the treatments under study. Major differences were not observed between fertilizer levels or sources. It can be inferred that fertilizer and water application methods did not influence P movement in soil considerably which accumulated mostly within 0-15 cm soil profile. Similar results with the expected slow movement of P in soil is also reported by Bacon and Davey (1989), Haynes (1985) and Papadopoulos (1992).

The residual K content in soil was also influenced considerably due to fertilizer and water application methods. The direct, controlled and frequent application of water and fertilizer resulted in relatively more accumulation of K in the effective root zone (0-30 cm) of fertigated plots (172.6-120.6 mg/kg soil) as compared to traditionally fertilized but drip irrigated plots (164.8-133.5 mg/kg soil) or conventional furrow irrigation (160.6-107.3 mg/kg soil). However, 'K' accumulation under fertigation showed reduced concentration in below root zone depth (138.6-97.5 mg/kg soil). While the other two treatments had considerably higher accumulation of residual K at lower depths (151.6-98.1 and 171.2-102.6 mg/kg soil respectively) indicating a potential leaching risk which was more severe in furrow irrigated plots in comparison with fertigated plots. Further, it can be observed that even at higher dose of potassium application (100%) K leaching was relatively less with fertigation compared to same dose of fertilizer applied in one basal application as followed in conventional method. This aspect can be further examined with the studies of Papadopoulos (1988) wherein he reported that leaching losses of K can be minimized by supplementing the 'K' source through ferti-drip system.

5.2.2 Nutrient uptake and Fertilizer Use Efficiency

The uptake of nutrients and the FUE in capsicum maize and sunflower were influenced significantly due to fertigation and non-fertigation treatments. The regulated supply of

water and nutrients directly to the root zone at different stages of crop growth resulted in adequate availability of these and with the increased density of functional roots in the root zone caused for greater uptake of nitrogen (32.2-31.4 kg ha⁻¹), phosphorus (9.2-8.8 kg ha⁻¹) and potassium (50.5 – 48.7 kg ha⁻¹) in capsicum during both the years of 1994 and 1996. Identical trend was recorded with maize and sunflower also (180.8-188.0, 34.3-35.1 and 163-170 kg ha⁻¹ in maize and 101.2-93.2, 17.4-16.4 and 67.0-62.5 kg ha⁻¹ in sunflower correspondingly), whereas the drip and furrow irrigation treatments resulted in low N, P and K uptake compared to fertigation. Therefore, with fertigation there were greater yield upgradation as a result of greater uptake of nutrients. Thus there were simultaneous in FUE of 38.7-38.8 kg kg⁻¹ NPK in capsicum, 19.4-19.3 kg kg⁻¹ NPK in maize and 9.05-8.2 kg kg⁻¹ NPK in sunflower. These improvements were 24-20%, 14-12% and 20-17% higher than FUE obtained with furrow method and 10-6%, 6-4%, and 7-6% higher than drip methods correspondingly. Thus, the current studies point out the possibility of enhancing the FUE through fertigation. Similarly, the findings of Isobe (1974), indicated that the nitrogen uptake in sugarcane was greater when the fertilizer was continuously applied along with water through drip system. However, non-uniform distribution and inadequate availability of nutrients and moisture in the root zone of a crop are responsible for lower uptake of nutrients and moisture. Thus in the current studies, the reduced levels of fertilizers (80%) levels and normal fertilizer source decreased the nutrient availability in soils resulting in lower yields in all the three crops of capsicum, maize and sunflower. There was reduced FUE also. However, when drip system was adopted the differences were not much with full dose on WSF while the furrow irrigation resulted in lower yields as well as FUE compared to drip system.

5.3 Root dry weight and root distribution pattern in capsicum, maize and sunflower as influenced by methods of irrigation and fertilization, levels and sources of fertilizers

Root system forms a crucial part of plant as absorber of moisture and nutrients thus controlling plant development. The current studies indicated that total root dry weight was higher in fertigation treatment irrespective of the levels or sources of fertilizer as compared to furrow



Plate 5.1 - Root growth in capsicum as influenced by furrow, drip and fertigation treatment

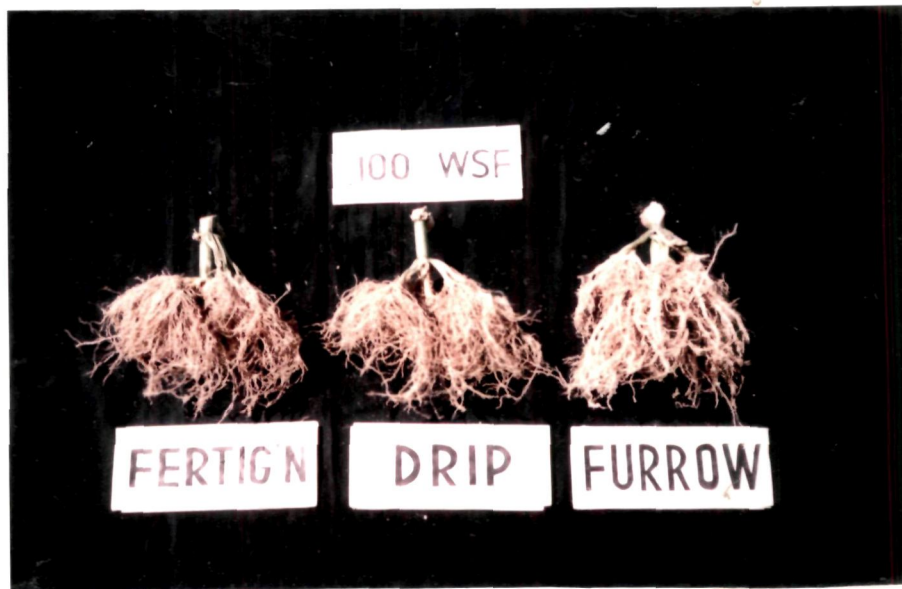

Plate 5.2 - Root growth in maize as influenced by furrow, drip and fertigation treatment



Plate 5.3 - Root growth in sunflower as influenced by furrow, drip and fertigation treatment

irrigation. Frequent supplementation of nutrients along with water under ferti-drip system increased the accumulation of available N, P and K in the crop root zone (Table-4.44 to 4.46) and therefore influenced in producing more number of total roots in capsicum (5.39-5.35 g plant⁻¹), maize (62.44-59.65 g plant⁻¹) and sunflower (36.03-34.28 g plant⁻¹) in both the years 1994-95 and 1996-97 as compared to plots with soil application of fertilizers followed by drip irrigation (5.1-4.93 g, 59.32-59.94 g and 34.69-30.42 g plant⁻¹ correspondingly) or furrow irrigation (5.03-5.28 g, 58.75-56.14 g and 31.83-29.73 g plant⁻¹ correspondingly). The varied fertilizer levels with or without fertigation also influenced the root growth wherein the recommended fertilizer dose (100%) produced higher root dry weight than the reduced (80%) dose. Similarly, the WSF fertilizer was superior for root growth as compared to NF source. A combination of 100% dose in the form of WSF in fertigation resulted in maximum root weight while the 80% dose through NF application in furrow had the lowest root dry weight in case of capsicum and maize but it was 80% dose WSF in sunflower. In general, treatment combinations under fertigation had maximum total root density than the rest of the treatments. This increase was mainly due to adequate availability of both moisture and nutrients in the crop roots zone thus leading to better proliferation of nutrients under ferti-drip system.

The depth wise distribution of roots was also influenced under furrow, drip and fertigation treatments. The roots were concentrated much within 0-10 cm with fertigation in all the three crops. Whereas root mass was distributed upto 0-20 cm soil under conventionally irrigated and fertilized treatments. Since the moisture and nutrient distribution was confined to upper strata (0-20 cm) of soil under fertigation, the feeder root distribution was found to be concentrated accordingly in capsicum (3.67-1.90 g plant⁻¹), maize (37.15-20.34 g plant⁻¹) as well as in sunflower (22.25-10.53 g plant⁻¹) (Table-4.43). The root mass was denser at 0-10 cm layer and then, it drastically got reduced at 10-20 cm soil depth in these treatments.

However, with furrow irrigation, the nutrients moved down the soil through percolation and leaching losses were high due to flooding. Hence, the surface (0-10 cm) distribution

of feeder root was less in all the three crops (2.51-1.97 g plant⁻¹ in capsicum, 26.2-20.1 g plant⁻¹ in maize and 15.3-11.3 g plant⁻¹ in sunflower) which gradually reduced between 10-20 and 20-30 cm soil layers. Fertilizer doses as full (100%) or reduced (80%) levels induced little variation in root distribution pattern in fertigation but moderately in furrow method. Similarly, fertilizer sources as either WSF or NF were identical in respect to root distribution.

Root distribution pattern in drip method was similar to fertigation system except that the root weight was relatively lower than ferti-drip treatment. Root studies in capsicum conducted by Keng and Lugo-Lopez (1979) also point out dense fibrous root growth towards the nutrient and moisture source in fertigation and band placement. Root growth restricted to upper surface of soil because of spatial distribution of nutrients and moisture is also confirmed by the findings of Goldberg and Shmueli (1971) and Goyal *et al.* (1988) in capsicum and Martinez-Hernandez *et al.* (1991) and Phene *et al.* (1991) in maize.

5.4 Effect of methods of irrigation and fertilizer application on growth parameters of capsicum, maize and sunflower

5.4.1 Growth components in capsicum

Among the growth components the plant height recorded was the highest under fertigation closely followed by drip method throughout the crop growth in both the years, excepting at 30 DAP in 1996 (Table-4.41).

Better growth of plants under fertigation is confirmed by the significantly increased leaf area and number of leaves per plant during 30, 60 and 90 days after planting (Tables-4.2 to 4.4). The leaf area to the tune of 4.08 to 4.13 cm² at 90 DAP stage in fertigation treatments compared to 373 to 394 cm² in drip and 314 to 337 cm² in furrow method showed the favourable influence of frequent application of fertilizer through irrigation over drip or furrow methods with soil application of fertilizers. Similarly, the total dry matter remained high in fertigation and drip methods 1.64 to

9.86 g plant⁻¹ as compared to furrow irrigation 1.50 – 1.68 g plant⁻¹ indicating higher vegetative growth at the early start.

Reduced growth and productivity under conventional irrigation has been attributed to rapid depletion of readily available soil moisture from the limited root zone (Proebsting *et al.* 1977). Under such circumstances, frequent irrigations would permit available water to be consistently maintained in the root zone while either frequent irrigations (Sadykov and Mikhel, 1981) or large moisture deficits (Sirjacobs and Dada, 1983) have been shown to affect adversely the growth and dry matter production.

The number of secondary branches and total number of branches were higher in fertigation (Table-4.7) in accordance with its vigorous growth as seen by improved leaf area and dry matter production. In capsicum, the number of branches have direct relationship to fruit yield as they serve as fruiting points. However, number of primary branches were not significantly influenced by fertigation.

Dry matter accumulation at 30 DAP showed no significant effect due to fertigation or drip over furrow method both in stem and leaf although these three treatments recorded stem and leaf dry matter in the descending order correspondingly (Table-4.5). The non-significant response may be due to high concentration of available nutrients in furrow and drip treatments because of high basal dose application of fertilizers. However, growth and dry matter accumulation was rapid at lower stages with fertigation. With improvement in stem dry matter, the leaf dry weight increased gradually as the age advanced upto 90 DAP ranging between 2.85 to 3.88 g per plant with fertigation as compared to 2.66 –3.65 g per plant in drip and 2.35-3.30 g per plant in furrow irrigation wherein the fertigation treatment was significantly superior to furrow method at 60 DAP in 1996, 90 DAP in 1996 and at harvest in 1994 but was on par with drip treatment always.



Plate 5.4 - Capsicum crop grown under furrow irrigation



Plate 5.5 - Capsicum crop grown under drip irrigation



Plate 5.6 - Capsicum crop grown under fertigation

Consequent to the improvement in leaf area, number of leaves, dry matter of the plant well supported by root growth and density, the fertigation treatments recorded higher fruit weight starting from 60 days after planting. The overall improvements in the fertigation treatments was thus effected by monitoring the moisture and nutrient supply to the crop nearly in consonance with the steady growth and development stages of the crop. Thus, fertigation produced higher fruit weight of 3.81-7.74 g plant⁻¹. The next in order was soil application of fertilizer followed by drip irrigation which ranged from 3.39-6.86 g plant⁻¹. The lowest fruit weights recorded were 2.93-5.84 g plant⁻¹ with furrow irrigation. Thus, fertigation produced 30-31% higher yields over the furrow method, whereas soil application of fertilizer followed by drip system increased the yield by 15.7-16.5% over the furrow method. In studies on drip irrigation, Ramesh (1986) observed that dry matter in chilli in furrow irrigation remained lower which was ascribed to non-availability of soil moisture continuously in the irrigation cycles. Also the beneficial effect of drip over furrow method of irrigation has been demonstrated by Kundarimani, 1977; Srinivas, 1986; Clyde *et al.* 1989; Gural *et al.* 1990; Hapse *et al.* 1990, Jahdavi *et al.* 1990 and Kataria and Michael, 1990 in several crops

From these observations, it can be inferred that fertigation generally effected significant increase in growth attributes of capsicum which were further reflected in terms of superior fruit yield compared to soil application of fertilizers as followed in drip and furrow irrigated capsicum.

5.4.2 Growth components in maize

Maize has been considered as a heavy feeder of nutrients. A perusal of the data (Tables-4.15 to 4.21) revealed that maize had constantly shown positive response to regular nutrient and moisture supply as achieved by fertigation. Such responses to fertigation in maize are well documented by Casallo, 1988; Cosserat *et al.* 1990; Gascho and Hook, 1991; Martinez-Hernandez, *et al.* 1991; Bassoi and Richard, 1995 and Watts and Schepers, 1995.

In the present investigations, amongst the water and fertilizer application methods, fertigation was found to be distinctly superior compared to drip irrigation and furrow method in almost all aspects of growth and yield of maize in both the years 1994 and 1996. Besides the improvement in plant height (Table-4.15) and number of leaves (Table-4.18), the leaf area of fertigated maize increased reaching a maximum of 5791.7 and 5735.1 cm² per plant as compared to 5623.7 and 5593.8 cm² per plant in drip, both the treatments being on par with each other but significantly superior to 5131.2 and 5218.7 cm² per plant obtained with furrow irrigation at 60th day (Table-4.16). Concurrent with these improvements in leaf area fertigated maize had an edge over drip or furrow irrigated crop in respect of LAI (0.29-3.18, 0.28-3.12 and 0.26-2.90 correspondingly) at three stages of crop growth. Improvement in leaf growth caused a slight increases in the number of leaves per plant. The combined effect of improvements in plant height, number of leaves and leaf area raised the dry matter production in fertigated maize well over those of furrow or drip methods (Table-4.19). At harvest, fertigated maize both in 1994 and 1996 fertigated maize had significantly higher DMP of 218.5 g and 223.7 g per plant as compared to 185.2 g and 190.6 g per plant in the furrow irrigated maize. However, the DMP of 203.9 g and 209.8 g per plant obtained with soil applied fertilizers followed by irrigation with drip method was on par with fertigation but superior to furrow method (Fig.4.7). Besides, there was a better dry matter accumulation (DMA) in growth components like stem, leaf, tassel, silk and cob from the early stages upto harvest (Table-4.20). During 1996, DMA of fertigated maize was superior (56.3 g/plant) compared to furrow irrigation coupled with soil application of fertilizers (47.4 g/plant). Similar increases in leaf DMA were observed. For instance, at 60th day leaf dry matter of 33.2 g (1994) and 32.6 g (1996) per plant with fertigation was significantly superior to both drip (29.3 g) and furrow (23.6 g) in 1994 but only to furrow (24.9 g) in 1996. Thus DMA had a favourable influence on yield especially in fertigated maize. Higher DMA in tassel, silk, cob sheath and cob of fertigated maize was seen in both the years compared to other treatments. Under the influence of fertigation, the DMA in tassel was higher by 15-11 per cent, the silk by 33-15 per cent and in cob sheath by 22-18 per cent at 60th day compared



Plate 5.7 - Maize crop grown under furrow irrigation



Plate 5.8 - Maize crop grown under drip irrigation



Plate 5.9 - Maize crop grown under fertigation

to furrow irrigated maize. The corresponding values at harvest were 24-22, 25-15 and 25-19 per cent.

At harvest, the DMA in cob of fertigated maize was significantly higher in both the years compared to furrow method but was on par with drip method. Thus, with an overall improvement in DMA in vegetative parts like stem and leaf, reproductive parts like tassel, silk, cob sheath and cob were improved in one or the other year effecting a better translocation of photosynthates and thus, resulting in higher yield of maize under fertigation.

The overall improvement in the growth and yield of maize was also due to greater availability of nutrients like N, P and K aided by optimum moisture and nutrient balance at the active root zone under fertigation.

5.4.3 Growth components in sunflower

Application of fertigation or drip irrigation for sunflower is only a recent practice. In consonance with the popular concept that fertigation is beneficial for vegetables and in situations where higher fertilizer applications are desired, the present investigations revealed that combining fertilization with irrigation was also helpful in improving the growth and yield of sunflower.

Fertigation afforded more plant height with increased number of leaves compared to the other two treatments (Tables-4.24 and 4.27). At the 60th day, when maximum leaf area was observed in all the treatments, the order of increase in the leaf area per plant was furrow (2437 and 2327 cm²), drip (2486 and 2383 cm²) and fertigation (2517 and 2411 cm²) wherein fertigation treatment was significantly superior to the first one but was on par with the second treatment. Eventually, the LAI also increased from 1.35 and 1.29 in furrow to 1.39 and 1.32 with drip and 1.40 and 1.29 with fertigation during 1995 and 1997 respectively (Table-4.26)



Plate 5.10 - Sunflower crop grown under furrow irrigation



Plate 5.11 - Sunflower crop grown under drip irrigation



Plate 5.12 - Sunflower crop grown under fertigation

The total dry matter production (DMP) increased at all the stages (Table-4.28). At harvest, the DMP increased from 96.8 and 90.4 g per plant in furrow irrigated sunflower to 109.1 and 101.2 g with drip method and 112.4 and 105.6 g per plant with fertigation. When the components of DMP were examined, again the favourable influence of fertigation was prominently observed. Both stem (42 g) and leaf dry matter (26 g) with fertigation were significantly superior to furrow irrigated plants (35-36 g and 16-18 g per plant respectively). Similarly the head dry matter at harvest showed significant improvement with fertigation treatment with values of 56.2 and 52.6 g per plant followed by 53.7 and 49.8 g per plant in drip and 47.2 and 44.7 g per plant in furrow method. This indicated higher diversion of photosynthates viz., current photosynthates and stored photosynthates to sink. Thus the growth attributes in sunflower were greatly influenced by fertigation. The increased growth and vigor was instrumental for enhanced yield. Also, several studies have found close correlation between total dry matter production and yield (Watson, 1952; Beese *et al.* 1982 and Horton *et al.* 1982).

5.5 Effect of methods of irrigation and fertilizer application, on yield and its components in capsicum, maize and sunflower

5.5.1 Yield and its components in capsicum as influenced by irrigation and fertilizer applications

Examination of green fruit yield of capsicum in different treatments showed that fertigation method of fertilizer plus water application recorded significantly higher fruit yield compared to furrow irrigation. Maximum green fruit yield of 9.39-9.25 tons per hectare was obtained with fertigation in both the years 1994 and 1996 as compared to crop (8.63 and 8.75 t ha⁻¹) and furrow methods (7.64 and 7.70 t ha⁻¹). This increase in green fruit yield was a reflection of better plant growth as evidenced by superior dry matter production under fertigation. Further, it was noticed that since pre-determined rate of water dissolved with nutrient was supplied to a specific soil volume, it helped to keep the entire root zone under low moisture tension. Hence, the plants were

not subjected to any stress during their growth period in contrast to furrow method where uneven distribution of nutrients was noticed across soil depths and stages of plant growth. These results are in confirmation with similar yield improvements due to fertigation in capsicum as reported by Keng and Lugo-Lopez, 1979. Tropea *et al.* 1982; Haes *et al.* 1987; Crespo-ruiz *et al.* 1988; Haynes, 1988; Goyal *et al.* 1989 and 1985.

The higher yield with fertigation over drip or furrow irrigation was associated with higher number of green fruit (6.91-6.75) per plant (Table-4.11) coupled with higher green fruit yield per plant (438-430 g). This was a consequence of better plant height (32-30 cm), number of branches (7.05-7.10) and leaf area (408-413 cm²) which helped in improved assimilation and translocation of photosynthates to growing fruits. On the other hand lower plant height (27-28 cm) in turn lower number of branches (6.3-6.4) and lower leaf area (313-337 cm²) reduced production and translocation of photosynthates to growing fruits ultimately resulting in lower number of green fruits (5.7-5.6) and lower green fruit yield (314-317 g) per plant with furrow irrigation. Similar observations of lower yields with furrow irrigation have been reported by Freeman *et al.* 1976, Vasanthakumar, 1984 and Narayanan, 1991).

The differences in yield among fertilization methods were the reflections of significant differences in fruit length and girth (Tables-4.12 and 4.13). Fertigated capsicums showed constantly bigger fruit size at all pickings especially during II and III pickings. In these harvests, 6.6-7.5 cm fruit length and 18.1-19.8 cm fruit girth were recorded with fertigation treatment as compared to 5.3-6.0 cm fruit girth and 16.1-17.6 cm fruit length obtained with furrow method. However, fruit size of drip irrigated capsicum was equal to fertigation. Better size of vegetables only under drip in sandy soils was recorded by Goldberg *et al.* (1971). Capsicum fruit yield and mean fruit size peaked at 252 kg N ha⁻¹ supplied in the form of Urea:ammonium nitrate mixture in weekly treatments through drip irrigation according to Hartz *et al.* 1993. Reduction in fruit size with reduced moisture supply as is the case with furrow irrigation was noticed by many and a few

reasoned it out to poor translocation of carbohydrates and low turgor (Begg and Turner, 1976). Abou-Husain *et al.* (1984) reported that fruit length, size and diameter increased with increase in field capacity percentage. Similar findings were obtained by other investigators (Dimitrov and Cherrenkove, 1976; O' Sullivan, 1979). In the current study, moisture and nutrient supply were steady with fertigation treatments which maintained field capacity to saturation and the nutrients here were within the root zone.

Quality parameter like ascorbic acid content of green fruits significantly varied due to the methods of fertigation and irrigation. Ascorbic acid content of green fruits recorded at third picking was the highest in fertigation (108.6-111.9 mg 100 g⁻¹ fresh fruit) as compared to 94.4-99.1 mg 100 g⁻¹ fresh fruit and 83.4-85.3 mg 100 g⁻¹ fresh fruit in drip and furrow respectively wherein fertigation was superior to both drip and furrow methods in 1994 but only to furrow method in 1996. Therefore Vitamin 'C' content responded positively to the easily available soil moisture and nutrients with fertigation. These results are in accordance with the results of Ramamurthy (1988) and Narayanan (1991).

5.5.2 Yield and its components in maize as influenced by irrigation and fertilizer applications

The effect of fertigation was distinctly superior in the grain and stover yield as well as on yield components of maize in confirmation with the observations of Cassallo, 1988; Cosserat *et al.* 1990; Gasho and Hook, 1991; Martinez-Hernandez, *et al.* 1991; Bassoi and Reichardt, 1995 and Blackmer and Schepers, 1995.

In the present investigation the yield related data indicated that fertigation enhanced the grain yield from 4157 and 4239 kg ha⁻¹ in furrow to 4756 and 4716 kg ha⁻¹ and the stover yield from 5384 and 5427 kg ha⁻¹ to 5578 and 5615 kg ha⁻¹. Such a positive response in maize has also been reported by Gasho and Hook, 1991. In their fertigation studies, with four N applications, grain and silage yields were greatest with fertigation and they opined that with optimum irrigation,

fertigation was most cost effective than dribbling N in sandy soils at Tifton, Georgia. In the current study, the increase in yield of maize has been supported by the improvements in yield attributes. The grain weight per cob increased by 19-15 g and the thousand grain weight by about 24-19 g as compared to furrow irrigated maize. Likewise, the grain number per cob increased from 467-475 to 505-499 while the shelling per cent from 74-73 to 78-76. The grain number per row and polificity per cent were also increased under the influence of fertigation (Table-4.23) in both the years 1994 and 1996. Such improvements in reproductive components were assisted by healthy and vigorous growth leading to better dry matter accumulation due to fertigation. Mertinez-Hernandez *et al.* (1991) reported that sweet corn showed higher marketable and total ear yields because of higher total fresh weight, dry matter production and plant height during the growing season with the aid of sub surface N, P and K fertigation. In this study, superior yield under fertigation was also due to better ear size as 19.2-20.3 cm cob length and 16.8-17.0 cm cob girth was bigger than 17.6-18.5 cm cob length and 15.3-15.8 cob girth produced by furrow irrigation (Table-4.23). However, , maize ears with drip irrigation were equal with those obtained under fertigation.

The significant improvement in yield and yield parameters observed due to combined use of irrigation and fertilizer are attributable to the overall growth and growth parameters like plant height, leaf area and dry matter accumulation. In the ferti-drip system the higher yields could be directly related to the direct controlled and frequent supply of moisture and nutrients to the effective root zone of the crop. This was possible because of one water outlet point on the chapin provided at the base of each plant and operated daily with water quantity equal to previous days evaporation. To maintain the concentration of fertilizer not to get too diluted in irrigation water, fertigation was imposed at biweekly intervals till the crop attained maturity. Thus the wetting zone at the base of the plants remained more or less constant. It was here in this wetting zone, that there was a maximum concentration of young functional feeding roots with fertigation (31 to 37 g/plant) compared to furrow irrigation (20 to 26 g/plant) (Table-4.42). This situation favoured better nutrient uptake and higher fertilizer use efficiency by 13 per cent (Table-4.38). All these factors contributed to enhanced yield and its components in maize with fertigation through chapin systems which can

thus become a promising new technology in achieving increased yields in maize while saving both water and fertilizer.

5.5.3 Yield and yield components in sunflower as influenced by irrigation and fertilizer applications

Sunflower growth was better under fertigation with the different growth components showing higher values as compared to furrow or drip irrigation. Consequently, the seed yield in the both years was also higher in fertigation registering 1621 and 1460 kg ha⁻¹ than 1519 and 1376 kg ha⁻¹ in drip or 1356 and 1248 kg ha⁻¹ in furrow (Table-4.32). Thus the fertigation produced 16.3-17% increase while the yield increase in drip was 6.7-6.3% of furrow irrigation.

Similarly, the stalk yield of 1710-1669 kg ha⁻¹, 1658-1629 kg ha⁻¹ and 1592-1551 kg ha⁻¹ in fertigation, drip and furrow followed the similar trend as that of seed yield. Increase in seed yield of sunflower due to fertigation by effluents enriched with nutrients has been reported by Papadopoulos and Stylianou, 1991.

The increase in seed yield in sunflower has been supported by the improvements in yield attributes. The seed yield per head increased by 6.9-7.0 g and the test weight by about 0.45-0.35 g as compared to furrow irrigated sunflower. Similarly the number of filled seeds per head increased from 678-652 to 784-745 and hence filling per cent from 73.8-74.7 to 80.5-79.4 in both 1995 and 1997. The husk per cent decreased by 1.5-0.8% under fertigation indicating more kernel content in seeds than with furrow method. The superiority of fertigation was also visible in terms of higher threshing per cent and head diameter (Table-4.32) over other treatments. Oil content was slightly higher with fertigation (47.8-45.0%) over drip (44.6%) and furrow (43.8-42.6) leading to significantly higher oil yields of 657 to 735 kg ha⁻¹ compared to 532 to 593 kg ha⁻¹ obtained with furrow method. Drip irrigation with 614 - 677 kg oil per ha was equal to other two treatments in 1995 but superior to furrow method in 1997 only (Table-4.33).

The variation in yield components and ultimately yield may be attributed to the differences in dry matter production at different growth stages. Regular nutrient supply through solution resulted in a significant response in terms of dry matter production of sunflower which eventually increased source and sink capacities. Similar studies of Sabina Aiyanna (1995) and Virender Singh (1996) in geranium indicated increased growth character like leaf area, canopy spread, number of leaves and leaf dry weight under ferti-irrigation caused an increased herbage yield and geranium oil yield by 40 per cent over traditionally irrigated and fertilized plots. From the present investigation it is clear that sunflower responded to fertigation method of combining fertilizer and water in terms of improved yield.

5.6 Effect of levels of fertilizer on growth and yield of capsicum, maize and sunflower

Fertilizer levels are known to effect improvements in biomass production in crop varieties. However, in the present study, although different attributes in capsicum, maize and sunflower were numerically higher with the recommended dose (100%) compared to reduced dose (80%), in general, these fertilizer levels were observed equal in influencing the performance of crops studied in the experiment.

In capsicum, 80% recommended dose of did not affect the fertilizers the green fruit yields (8423 kg and 8422 kg ha⁻¹ averaged over 12 treatments) compared to 100% recommended fertilizer level (8685 and 8693 kg ha⁻¹). This was because most of the yield parameters also did not differ among themselves for variation in fertilizer levels. Though fruit yields in 1996 during the I and II pickings were significantly superior with 100% dose, the total yields for all the four pickings were however similar to those of 80% fertilizer level. Thus these results indicate that reducing fertilizer dose by 20% may not reduce capsicum yield substantially and hence a saving of 20% fertilizer can be realized. Similar trend was recorded by Madramooto and ^{Rigby} (1989) when 3 levels of nitrogen (67.5, 45.0 and 22.5 kg ha⁻¹) applied as ammonium nitrate in trickle irrigation did not cause any significant change in capsicum yields.

In maize during 1994, the growth in general was not influenced by the levels of fertilizer. In 1996, the plant height (171.8 cm) and leaf area at harvest (1393 cm²) with 100% fertilizer dose were significantly superior to 163.5 cm and 1228 cm² respectively obtained with 80% dose. Yet dry matter production due to 100% level was on par with the reduced (80%) dose at 60th day and at harvest, whereas it was superior at 30 and 90th day in 1996 (Table-4.19). Among the yield and its components, full dose fertilizer caused for significant increase in grain yield in 1994. This was, largely due to increase in grain number per cob and a few yield attributing factors. Also, the mean yield data was especially influenced by the higher yield obtained with 100% fertilizer dose in furrow irrigation. This was however not reflected in the interaction effects. During 1996, though grain yields were not influenced by fertilizer levels, the stover yields were better with 100% fertilizer level due to some improvements in plant height, leaf area and dry matter at some stages. These results are concordant with the work of Bullock *et al.* (1990) who found 168, 252 and 336 kg N ha⁻¹ applied in 4 equal fertigation with 3 levels of P and K applied to soil did not affect grain yield in maize. It was suggested that NUE of a fertigated maize crop may be improved by dressing N fertilizer rates below current recommendations. Also, tissue N, P and K concentration increased with decreasing N, P and K application respectively. In the current study, the fertilizer use efficiency was higher with lower fertilizer dose and hence the performance of maize was not affected considerably due to small variation in dose of fertilizers by 20 per cent.

With regard to sunflower, although the trend was identical as seen in maize and capsicum, head dry matter in 1995 and only a few growth attributes like plant height at 60 DAS, leaf area at 30 DAS in 1996 were found significantly superior under the influence of 100% fertilizer dose as compared to 80% dose. Further, the stalk yield (1660 kg ha⁻¹) in 1996 and some yield components, particularly the number of filled seeds (774-737) per head were found maximum with higher fertilizer dose than with lower dose (1573 kg ha⁻¹ and 695-676 seeds correspondingly).

These results indicated that decreasing fertilizer level by 20% than the recommended level especially under fertigated conditions may not affect the yield level in sunflower because of improved fertilizer use efficiency at the lower fertilizer dose.

5.7 Effect of fertilizer sources on growth and yield of capsicum, maize and sunflower

Fertigation technology is new and use of water soluble fertilizers is recognized to safeguard the drip system in the long run. The normal fertilizers generally tend to clog the emitters and cause uneven distribution of fertilizers. In order to make the comparison even, in the current experiment, the normal fertilizers were dissolved in water and only clear supernatant fertilizer solutions were fed to the drip system. Even with this precaution, the drip system had to be flushed with dilute acid solution once after each crop. In case of WSF, these cumbersome processes were not required. Thus, for large scale field applications compared to small experimental plots as in the current study, the use of normal fertilizers cannot be said to be practicable or helpful in the long run. However, for comparison on equal nutrient basis, both WSF and NF in the current studies showed similar results. The long term ill-effects if any on the chapins and outlet points through use of NF have not been made. Thus, fertilizer sources as water soluble or normal fertilizer applied in furrow, drip and fertigation generally did not cause significant differences in most attributes observed in capsicum, maize and sunflower. The normal fertilizers used in the experiment were urea, superphosphate and potassium chloride as N, P and K sources respectively whereas the 100% water soluble fertilizer formulations were supplied by Kemira Agro, Finland.

As the growth parameters in all three crops showed little variation due to sources of fertilizer, the green fruit yield in capsicum (8544 and 8563 kg ha⁻¹) grain yield in maize (4464 and 4496 kg ha⁻¹) and seed yield in sunflower (1490 and 1372 kg ha⁻¹) respectively in 1994-95 and 1996-97 with the use of water soluble fertilizer were equal to yields obtained with the application of normal fertilizers (8564 and 8573 kg ha⁻¹ fruit yield, 4468 and 4484 kg ha⁻¹ grain yield and 1507 and 1351 kg ha⁻¹ seed yield correspondingly). However, the quality of capsicum in terms of vitamin 'C'

content was enhanced with WSF. It increased from 91.1 and 94.1 mg/100 g fresh fruit⁻¹ in NF to 100.0 and 103.4 mg/100 g fresh fruit⁻¹ with WSF as recorded at third picking in 1994 and 1996 respectively. Thus, it can be inferred that WSF had an edge over NF in influencing the quality of capsicum vegetable. Other increases associated with WSF application in a few attributes spread randomly among the different observations recorded were not effective in influencing the yield of capsicum, maize and sunflower to a considerable extent during both the years. Equal response expressed by both the fertilizer sources may be due to fact that the normal fertilizers urea, super phosphate and potassium chloride were also used in formulations of grades for water soluble fertilizers and hence exhibited comparable values in use efficiency (Table-4.38) and other related attributes. However, it was observed that use of WSF in fertigation was convenient as normal straight fertilizers when applied through drip was labour intensive and time consuming for a through pre-filtering before introducing into fertigation tank. Especially both superphosphate and potassium chloride (fertilizer grade) caused sedimentation on dissolution in water while the Water Soluble Fertilizers (used from Kemira-OY, Finland) were safe and easy as they were specially designed for direct use in fertigation system. Urea as a N source for fertigation is well documented by Muirhead *et al.* 1985; Haynes, 1985, 1988; Crespo-Ruiz *et al.* 1988 and Goyal *et al.* 1989.

5.8 Interaction effects of methods of irrigation, levels and sources of fertilizer on performance of capsicum, maize and sunflower

With regard to different interaction effects of the main factors i.e. irrigation/fertilization methods x fertilizer levels or irrigation/fertilization methods x fertilizer sources or fertilizer levels x fertilizer sources or irrigation/fertilization methods x fertilizer levels x fertilizer sources, none of the interactions were found significant in any of the growth or yield parameters studied in capsicum, maize or sunflower. However, a closer examination of the data recorded in various parameters revealed some general trends in each case.

5.8.1 Interaction between irrigation/fertilization methods and fertilizer levels

The trend pertaining to interaction between irrigation/fertilization methods and fertilizer levels indicated that the influence of lower dose (80%) fertilizer was greater in magnitude in drip or furrow method of irrigation than in fertigation. For instance, in case of capsicum the reduced dose reduced the green fruit yield by 3.4% and 3.2% (mean of two years) in furrow and drip methods respectively whereas it was 2.3% reduction in case of fertigation as compared to the full dose (100%) fertilizer (Table-4.29). Corresponding yield reductions were 8%, 6.7% and 4.3% in maize and 3.4%, 3.2% and 2.3% in sunflower (Tables-4.31 and 4.32) suggested that proportionate yield reduction in capsicum, maize and sunflower due to 20% reduction in fertilizer in fertigation was not so severe as observed in furrow or drip methods and hence a saving of 20% on fertilizer cost is possible under fertigation. This advantage in fertigation realized may be because of higher fertilizer use efficiency which is facilitated by easy availability of nutrient and less wastage eventually effecting vigorous plant growth. The results are in line with the findings reported by Madramooto and ^{Rigby} (1989), Olsen *et al.* (1993); Carbollo *et al.* (1994).

5.8.2 Interaction between irrigation/fertilization methods and fertilizer sources

Interaction between irrigation and fertilization methods and fertilizer sources revealed that in general, use of WSF was not beneficial in case of drip or furrow method but was slightly superior to NF in fertigation. Application of WSF in furrow method reduced capsicum green fruit yield by 93-103 kg ha⁻¹ and in drip method by 66 kg ha⁻¹ than the NF source but the response was not consistent in maize and sunflower. This performance of WSF in furrow or drip method may be due to loss of nutrients by leaching when applied to soil in bulk quantity as basal dose followed by furrow irrigation or applied to soil followed by drip-irrigation system.

5.8.3 Interaction between fertilizer levels and sources

In general, the 100% dose irrespective of source was superior to lower dose (80%) effecting higher growth and yield components in capsicum, maize and sunflower than the reduced dose. However, the fertilizer use efficiency became significantly higher with 80% dose as the yield increase due to increased fertilizer level by 20% was not significant.

5.8.4 Interaction effect among irrigation/fertilization methods, fertilizer levels and its sources

Although the interaction effects were non-significant, the trend indicated that in general, a combination of higher dose (100%) fertilizer in the form of WSF source applied through fertigation gave the highest values in most of the attributes in capsicum, maize and sunflower followed by 80% dose WSF, 100% dose NF and 80% dose NF in fertigation. In this order, the green fruit yield in capsicum were 9.50, 9.36, 9.22 and 9.20 tons ha⁻¹ (mean of two years); the maize yields were 4.82, 4.76, 4.68, 4.68 tons ha⁻¹ respectively and the sunflower yields were 1.61, 1.54, 1.51, 1.50 tons ha⁻¹ seed yield respectively.

In drip method, 100% WSF was superior in capsicum (8.84 t/ha) and sunflower (1.49 t/ha) while it was 100% NF which was superior in maize (4.99 t/ha).

With furrow irrigation capsicum, maize and sunflower yields (7.85, 4.27 and 1.38 tones ha⁻¹ respectively) recorded with 100% dose NF was the highest followed by 100% dose WSF which in turn was superior to 80% dose NF. The least values among all the treatments studied in the experiment was registered with 80% dose WSF in furrow irrigation (7.48, 4.13, 1.24 tons ha⁻¹ capsicum, maize and sunflower yields respectively). From these data it can be inferred that fertigation method irrespective of different treatment combinations was the most superior method of

applying fertilizer and water as compared to soil application of fertilizers followed by furrow or drip methods of applying water in capsicum, maize and sunflower.

5.9 Economic analysis of fertigation in capsicum, maize and sunflower cropping sequence

Economics on the use of WSF and NF in fertigation revealed that improved gross and net returns and hence better C:B ratio were obtained in fertigation as compared to either drip method or furrow method. Although, the fertilizer cost was more with WSF (Rs.5,717 to 10,202) the operational costs were lower (Rs. 1,600-11,050) in fertigation and thus resulted in superior net returns (1,77,861-1,75,892 Rs./ha) at the end of the experiment.

Fertigation as a method of fertilizer and water application irrespective of sources or levels of fertilizer resulted in 2.98 Rs. per rupee investment whereas the drip and furrow methods registered C:B ratio of 2.63 and 2.46 respectively. The initial cost of the drip system (Rs.35000/ha) can be recovered with the first crop of capsicum itself. In case of tomato, the payback period is only one season (Sivanappan, 1996). In this context, Moll (1996) observed that, though the flood system is considerably cheaper to install drip system, the low annual operating costs in drip method outweighs its initial expense and make it the most financially and environmentally attractive system. In the present investigation, it has been observed that higher returns under fertigation could not only improve FUE but also increase yields and C:B ratio.

Future line of work

1. Fertilizer schedules should be matched with the nutrient demands of the crops. Since crops have varied demands at various stages of growth, intensive studies are needed in this regard.
2. Identification of high value crops and their sequence needs be examined to maximize benefits from fertigation.
3. Greater insight is needed on fertigation system with regard to maximizing WUE and FUE while simultaneously reducing the risks of soil and water pollution.

Results of extension value

1. There is an urgency to save water and costly inputs of fertilizer. This investigation suggests that transfer of technology of drip system instead of furrow irrigation and adoption fertigation through chapin drip for the entire cropping sequence of Capsicum-Maize-Sunflower, be taken up on a large scale.
2. "Cropping system rather than individual crops" should be the principal approach to be demonstrated with inclusion of at least one high value crop such as Capsicum or Tomato.

SUMMARY

VI. SUMMARY

An agronomic investigation on "Effect of fertigation with normal and water soluble fertilizers compared to furrow and drip systems in capsicum-maize-sunflower cropping sequence" was carried out at the Main Research Station, University of Agricultural Sciences, Bangalore during two years 1994-95 and 1996-97.

Twelve treatments combinations involving three methods of irrigation viz., furrow, drip and fertigation each in combination with 80% and 100% of water soluble or normal fertilizers were compared and assessed for their performance of the entire cropping sequence of capsicum-maize-sunflower in a split-split plot design with three replications. The irrigation water was conveyed through chapin pipes without altering their position for all the six crops. The salient feature of the investigation are summarized and presented here.

1. The study on the soil moisture distribution revealed that at the top 0-30 cm soil depth both drip and fertigation had relatively more soil moisture content (24.3-28.2 %) upto 20 cm distance from the crop row indicating good availability of moisture in the root zone of crops. In contrast, in the furrow method lower soil moisture content (17.8-22.2 %) at the top 0-30 cm layer upto 20 cm distance from crop row was recorded. Even this soil moisture status was not maintained constantly due to cyclic nature of furrow irrigation of biweekly intervals while constant moisture regime was maintained in drip and fertigation throughout the crop growth period by daily operation of drips with water quantity equal to previous days open pan evaporation. Further, deep percolation of water was also noticed at below root zone (30-60 cm) which was absent in fertigation and drip systems where concentration of wetting zone was restricted to the active root zone of capsicum, maize and sunflower.

2. The IWUE significantly increased by 56.6% and 52.9% during 1994 and 1996 respectively with fertigated capsicum and by 44.2 and 45.1% respectively with drip method over the green fruit yields of capsicum of 1.29 and 1.93 kg M⁻³ obtained under furrow method. Similarly increase in IWUE to an extent of 46.7-41.6% and 39.1-35.9% in maize as compared to 1.35-1.26 kg M⁻³ grain yield was observed under furrow method. The corresponding values for sunflower were 61-50%, 50-39% and 0.29-0.27 kg M⁻³ seed yield which indicated that both fertigation and drip were effective in improving IWUE. No major differences in IWUE was observed due to levels or sources of fertilizer or their interactions with irrigation methods.
3. Study on nutrient distribution pattern indicated that the residual NO₃-N was confined to the effective root zone (0-30 cm) in fertigation (31.8-16.7 mg/kg soil) with least of leaching. In furrow and drip irrigations, soil application of fertilizers as basal dose and top dressing resulted in relatively lower NO₃-N accumulation in 0 to 15 cm soil in drip (14.8-23.6 mg/kg soil) and furrow, (13.5-15.5 mg/kg soil) methods. In these systems, leaching losses of NO₃-N was detected at subsurface (15-30 cm) layers (16.5-26.3 mg/kg soil) and beyond root zonal depths as compared to fertigation methods. Full dose of fertilizer (100%) and WSF source resulted in slightly higher soil NO₃-N content than the reduced dose (80%) and the NF source respectively
4. The residual P accumulation was satisfactory in the top soil layers (0-15 cm) when it was fertigated (5.7-15.6 mg/kg soil) and also at 15-30 cm soil depth (2.8-6.3 mg/kg soil). 'P' level was relatively higher at the top soil (8.2-18.5 mg/kg soil) in furrow method as compared to drip method (5.5-15.5 mg/g soil).
5. Relatively more accumulation of K was noticed in the effective root zone (0-30 cm) (120.6-172.6 mg/kg soil) of fertigated plots as compared to traditional fertilized but drip irrigated plots (133.5-164.8 mg/kg soil) or conventional furrow irrigation (107.3-160.6 mg/kg soil). At deeper layers, reduced concentration of K was observed in fertigation (97.5-138.6 mg/kg soil) while there was

high accumulation of residual 'K' (98.1-151.6 in drips and 102.6 and 171.2 mg/kg in furrow respectively).

6. The uptake of nitrogen (31.4-32.2 kg/ha), phosphorus (9.2-8.8 kg/ha) and potassium (50.5-48.7 kg/ha) in capsicum during both the years 1994 and 1996 was greater with fertigation. Identical trend was recorded with maize and sunflower also (180.8 – 188.0 kg, 34.3-35.1 kg and 163-170 kg/ha in maize and 932-101.2 kg, 16.4-17.4 kg and 62.5-67.0 kg/ha in sunflower) correspondingly, whereas the drip and furrow treatments caused lower N, P and K uptake compared to fertigation.
7. The FUE with fertigation was 38.7 and 38.8 kg/kg NPK in capsicum, 19.4-19.3 kg/kg NPK in maize and 8.2-9.05 kg/kg NPK in sunflower (24-20%, 14-12% and 20.17% higher than furrow method and 10-6%, 6-4% and 7.6% higher than drip methods correspondingly).
8. The root dry weight was higher in capsicum (5.35-5.39 g/plant), maize (62.44-59.65 g/plant) and sunflower (34.28-36.03 g/plant) in fertigation treatment irrespective of fertilizer levels or sources as compared to plots with traditionally fertilized but drip irrigated (4.93-5.4 g, 59.32-59.94 g and 30.42-34.69 g/plant correspondingly) or furrow irrigation (5.03-5.28 g, 58.75-56.14 g and 31.8-29.7 g/plant correspondingly).
9. Capsicum growth was superior with fertigation as the growth components viz., plant height, leaf area, number of leaves, number of primary and secondary branches were improved by fertigation which eventually resulted in significantly higher dry matter production at all stages of growth. The leaf area of 408-413 cm², 373-394 cm² and 314-337 cm² recorded at 90 DAP with fertigation, drip and furrow respectively and total dry matter of 19.9-19.3 g, 18.0-18.3 g and 14.8-15.6 g at harvest indicated the superiority of fertigation over other two treatments.

10. Green fruit yield with fertigation was maximum in capsicum (9.25-9.39 t/ha) as compared to drip (8.63-8.75 t/ha) and furrow (7.64-7.70 t/ha) methods.
11. Plant height, leaf area, number of leaves and LAI of maize improved with fertigation resulting in 218.5 g and 223.7 g dry matter per plant in 1994 and 1996 respectively as compared to 203.9 g and 209.8 g per plant in drip or 185.2 g and 190.6 g per plant in the furrow method.
12. Maize grain yield increased from 4.48-4.51 t/ha in drip and 4.16-4.23 t/ha in furrow method to 4.76-4.72 t/ha with fertigation registering 4.7 and 14.4% increase respectively. This was caused by superior yield attributes like grain number per row, number of grains per cob, grain weight per cob test weight, cob length and girth and prolificity per cent.
13. Fertigation afforded better growth in sunflower with the different growth components showing higher values as compared to the traditional management or soil application of fertilizer followed by drip irrigation. Leaf area at 60th day was maximum in fertigation (2411 to 2877 cm²) followed by drip (2486 and 2383 cm²) and furrow (2437 and 2327 cm²) systems. The head dry matter was 47.2-44.7 g/plant in furrow, 53.7 and 49.8 g/plant in drip and 56.2 and 52.6 g/plant in fertigation.
14. Sunflower seed yield in both the years 1995 and 1997 was also higher in fertigation registering 6.7-5.7% and 19.5-17.0% over drip and furrow systems respectively. This increase in seed yield was particularly due to increased filling per cent from 73.8-74.7% in furrow irrigation to 80.5-79.4% in fertigation. Though oil content did not vary among the treatments (42.6-47.8%), oil yield was higher by 144-125 kg ha⁻¹ in fertigation over 593-532 kg ha⁻¹ obtained in furrow method.
15. Reduced level of fertilizers of 80% did not generally affect the performance of capsicum, maize and sunflower compared to 100% level.

16. Fertilizer sources as water soluble or normal fertilizer applied in furrow, drip or fertigation generally did not also cause significant influence on any attributes in capsicum, maize or sunflower. However, the WSF source improved the quantity of capsicums in terms of Vitamin 'C' content from 91.1 and 94.1 mg/100 g fresh fruit in NF to 100.0 and 103.4 mg/100 g fresh fruit at III picking in 1994 and 1996 respectively. Thus the WSF source had an edge over NF in influencing the quality of capsicum vegetable.
17. Application of NF i.e., urea, superphosphate and muriate of potash in fertigation was feasible on this small scale experimentation. However, it was time and labour intensive as they should be pre-filtered and then incorporated into irrigation water. Both superphosphate and muriate of potash caused sedimentation on dissolution while urea was mostly suitable for fertigation purpose.
18. All the interactions were non-significant. However, the interaction between irrigation methods into fertilizer levels indicated that reducing fertilizer dose by 20% caused more yield reduction in capsicum, maize and sunflower especially in furrow method than with fertigation indicating a saving on fertilizers only in case of WSF. Interactions in irrigation methods and fertilizer sources are suggestive of the fact that WSF are not fit for traditional methods of soil application.
19. Fertigation treatments irrespective of levels or sources of fertilizer resulted in the highest net returns in capsicum (62,817-77,370 Rs./ha), maize (11,096-19,238 Rs./ha) and sunflower (7,993-13,316 Rs./ha) as compared to drip method (54,787-72,480, 9,119-18,032 and 6,395-12,736 Rs./ha respectively) and traditional furrow method (47,216-63,800, 8,180-17,205 and 5,053-11,207 correspondingly).

These investigations brought out the salient features that fertigation with WSF is feasible for the whole cropping sequence of Capsicum – Maize – Sunflower effecting a saving of 20% in fertilizer, 23% in water, improving C:B ratio 2.98 and preventing pollution and loss of fertilizer nutrients through leaching to below root zone.

REFERENCES

VII. REFERENCES

- Abou Hussein, M.R., El-Bettagy, M.S., El-Bettagy, A.S., Khalil, S., Mak Soud, M.A. and Abdel-Halim, S.M., 1984, Effect of soil water availability on growth flowering and fruiting of pepper plant. *Egypt J.* 74 : 556-561.
- Bacon, P.A. and Davey, B.G., 1989, Nutrient availability under trickle irrigation-phosphate fertilization, *Fert. Res.*, 19 : 159-167.
- Bar-Yosef, B., 1991, In : Fluid fertilizer, Science and Technology, Palgrave, D.A. (ed.) *Chaser fertilizers*. Britag Industries Ltd., Chedburgh, Suffok, England, Marcel Dekker, Inc. New York, USA.
- Bar-Yosef, B., Sagiv, B. and Markovitch, T., 1989, Sweet corn response and subsurface trickle phosphorus fertigation. *Agron. J.*, 81 : 3, 443-447.
- Bassoi, L.H. and Reichardt, K., 1995, Nitrate leachings in a structured dusky red latosol cultivated with ferti-irrigated maize. *Revista-Brasileira-de-Ciencia-do-solo.* 19 : 3, 329-335.
- Bassoi, L.H., Fante-Junior-L., Jorge, L.A.C., Crestana, S. and Reichardt, K., 1994, Distribution of root system in maize grown in a Kaudalfic eutrodox Soil : II. Comparison between irrigated and fertigated crops. *Scientia-Agricola.* 51 : 3, 541-548.
- Bessay, D.A. and King, C.G., 1933, The distribution of vitamin C in plant and animal tissues and its determination. *J. Biol. Chem.*, 103 : 687-698.
- Beese, T., Horton, R. and Wierenger, 1982. Growth and yield response of Chile pepper to trickle irrigation. *Agron J.*, 72: 3, 556-561
- Begg, J.E. and Turner, N.C., 1976, Crop water deficits. *Adv. Agron.*, 28 : 161-217.
- Ben-Asher, J., Fuchs, M. and Goldberg, D., 1978. Radiation and energy balance of sprinkler and trickle irrigated fields. *Agron. J.* 70 : 415-417.
- Black, J.D.F., 1976, Trickle irrigation – A review. *Hort. Abst.* 46, 1-7, 69-74.
- Blackmer, T.M. and Schepers, J.S., 1995, Techniques for monitoring crop nitrogen status in corn. *Comm. Pl. Sci. Soil Analysis.* 25 : 9-10, 1791-1800.
- Bucks, D.A., Nakayama, F.S. and Warrick, A., 1981, Principles of trickle (Drip) irrigation. In *Advances In Irrigation*. Academic Press. Inc. New York. 220-299.
- Bullock, D.G., Gascho, G.J. and Summer, D.R., 1990, Grain yield, stalk rot, and mineral concentration of fertigated corn as influenced by NPK. *J. Pl. Nutrition.* 13 : 8, 915-937.

- ✓ Bullock, D.G., Gascho, G.J. and Summer, D.R., 1990, Grain yield, stalk rot, and mineral concentration of fertigated corn as influenced by NPK. *J. Pl. Nutrition* 13 : 8, 915-937.
- ✓ Camp, C.R., Sadler, E.J. and Busscher, W.J., 1986, Surface and subsurface trickle irrigation for corn. *Paper, Am. Soc. Agril. Engineers*. No. 86-2571, 7pp.
- ✓ Carbollo, S.J., Blankenship, S.M., Sanders, D.C. and Ritchie, D.F., 1994, Drip fertigation with nitrogen and potassium and post harvest susceptibility to bacterial soft rot of bell peppers. *J. Pl. Nutrition*. 17 : 7, 1175-1191.
- ✓ Casallo, A., 1988, Cultivation of maize in ridges. *Agricultura Madrid*. 57 : 666, 52-53.
- ✓ Clyde, R.B., Timothy, K.H. and Carlos, N., 1989, Comparison of subsurface, trickle and furrow irrigation on plastic mulch and bare soil for tomato production. *J. Amer. Soc. Hort. Sci.*, 114 : 40-43.
- ✓ Cosserrat, M., Decau, J., Patacq-Crouzet, H., Pujol, B. and Calvet, R., 1990, Fertigation in Coarse-textured soil. Effects on nitrate production and nitrate solution. Nitrates-Agriculture-Water. *Int. Symp., Paris-La-Defense*, 7-8 Nov. 1990, 257-262.
- ✓ Crespo-Ruiz, M., Goyal, M.R., Baez, C.C.-de and Rivera, L.E., 1988, Nutrient uptake and growth characteristics of nitrogen fertigated sweet peppers under drip irrigation and plastic mulch. *J. Agril. Univ. of Puerto Rico.*, 72 : 4, 575-584.
- ✓ Dalbro, K. and Dorph-Peterson, K., 1976, Soil sampling in drip-irrigated glasshouse. *Tidsskrift for Planteavl*. 80 : 651-655.
- ✓ Dastane, N.G., 1967, *A practical manual for water use research*. Navabharath Prakashana Publication, Poona. P. 120.
- ✓ Decau, J. and Pujol, B., 1995. Lysimetric study of cropping techniques : influence of nitrogen dynamics under maize monoculture : absorption and leaching. Lysimetric evaluation and control of nitrogen transfers. Colloquium organized by COMIFER, 4-5 April, 1995. *Comptes-Rendus-de-l' Academie-d' Agriculture-de-France*, 1995, 81:4, 163-174.
- ✓ Dimitrova, Z. and Cherenkova, Z., 1976. The effect of cultural practices on the yield and quality of capsicum. *Hort. Abstr.* 48 : 1456.
- ✓ El-Gindy, A.G.M., 1984, Optimization of water use for pepper crop. *Am. Agric. Sci.*, 29 : 539-556.
- ✓ Francis, D.J., 1990, Nitrogen uptake by corn from fertilizer and irrigation sources. Dissertation-Abstracts - Int-B, *Sciences and Engineering*. 50 : 7, 2681B- 2682B.
- ✓ Freeman, B., Blackwell, J. and Garsoli, K.V., 1976, Irrigation frequency and total water application with trickle and furrow systems. *Agric. Water Mgt.* 1 : 21-31.

- Freney, J.R., Simpson, J.R., Denmead, D.T., Muirhead, W.A. and Leuning, R., 1985, Transformations and transfers of nitrogen after irrigating a cracking clay soil with a urea solution. *Australian J. Agril. Res.* **36** : 5, 684-694.
- Gascho, G.J. and Hook, J.E., 1984, Nitrogen management for irrigated corn grown on sand. *Fert. Issues.* **1** : 1, 1-6.
- Gascho, G.J. and Hook, J.E., 1991, Development of fertilization program for sprinkler irrigated corn. *J. Prodn. Agril.*, **4** : 3, 306-312.
- Girardin, P.H., Trendel, R., Meyer, J.L., Birgaentzle, M., Freyss, P. and Fragoso, M.A.C. (ed.), Beusichem, M.L-Van, 1992, Effect of conventional and multiple N application by fertigation on maize grain yields and NO₃-N residues. Optimization of plant nutrition : refereed papers from the *Eighth Int. Colloquium for the Optimization of Plant Nutrition*, 31 August – 8 September, 1992, Lisbon, Portugal, 1993, 411-415 : Dev. Pl. Soil Sci. **53** : 6 ref.
- Goldberg, D. and Shmueli, 1970, Drip irrigation – a method used under arid and desert conditions of high water and soil salinity. *Trans. Am. Soc. Agric. Eng.* **13** : 38-41.
- Goldberg, D. and Shmueli, M., 1971. Sprinkle and trickle irrigation of green pepper in an arid zone, *Hort. Sci.* **6** : 559-562.
- Goldberg, D., Gornat, B. and Bar, V., 1971, The distribution of roots, water and mineral as a result of trickle irrigation. *J. Am. Soc. Hort. Sci.*, **96**(5) : 645-648.
- Goldberg, D., Ben-Asher, J. and Gornat, B., 1976. Soil and plant water status under sprinkling and trickling. *Agric. Wat. Mngmt.* **1**, 33-40.
- Gomez, K.A. and Gomez, A.A., 1984, *Statistical procedures for Agricultural Research*. An International Rice Research Institute Book, Wiley-Inter Science Publication, New York, USA, P.680.
- Goyal, M.R., Rivera, L.E. and Santiago, C.L., 1985, Nitrogen fertigation in drip irrigated peppers, tomato and egg plants. *Drip/Trickle irrigation in action*. Vol. I. 388-392
- Goyal, M.R., Crespo-Ruiz, M. and Rivera, L.E., 1988, Root distribution of nitrogen fertigated sweet peppers under drip irrigation. *J. Agril. Univ. of Puerto Rico.* **72**(1) : 51-55.
- *Goyal, M.R., Gonzalea, E.A., Rivera, L.E., Chao, D.E. and Baez.C., 1989. Sweet pepper response to drip irrigation. Paper *Am. Soc. Agril. Engg.*, **87** :2423, pp.12.
- Goyal, M.R., Guadalupe-Luna, R., Hernandez, E.R.-de., Chao-de-Baez, C., De-aez, C.C.-de and De-Hernandez, E.R., 1989, Post-harvest evaluation of nitrogen fertigated sweet peppers under drip irrigation and plastic mulch. *J. Agril. Univ. of Puerto-Rico*, **73**:2, 109-114.

- Gratez, D.A., Fiskell, J.G.A. and Myers, J.M., 1978, Chloride and bromide movement with trickle irrigation of bell peppers. *Proc Fla State Hort. Soc.*, 91 : 319-322.
- Gutal, G.B., Chougule, A.A. and Jahdavi, S.S., 1990, Irrigation scheduling for sugarcane through trickle irrigation system, *Proc XI Int. Cong. on the use of Plastics in Agric.* New Delhi, pp. B.159-163.
- Hagin, J. and Lowengart, A., 1996, Fertigation for minimizing environmental pollution by fertilizers. *Fert. Res.*, 43 : 1-3, 5-7.
- *Hamdy, A., Maticic, B. and Petrac, M., 1993, Fertigation : Corn response of nitrogen fertilizer (Welte, E., Szaboics, I. Eds.), Budapest-CEC. Pp. 72-82.
- Hapse, D.G., Deshmukh, A.S., Gunjal, B.B. and Shinde, P.P., 1990. Evaluation of micro irrigation systems in sugarcane agriculture. *Proc XI Int. Cong. On the use of Plastics in Agric.* New Delhi, pp. 41-47.
- Hartz, T.K., Le Strange, M. and May, D.M., 1993, Nitrogen requirements of drip irrigated peppers. *Hort. Science.* 28 : 11, 1097-1099.
- Haes, J.H., Bar-Yosef, B., Krikun, J. Barak, R., Markovitz, T. and Kramer, S., 1987, Vesicular-Arbuscular mycorrhizal fungus infection and phosphorus fertigation to overcome pepper stunting after methyl bromide fumigation. *Agron. J.* 79 : 5, 905-910.
- Haynes, R.J., 1985. Principles of fertilizer use for trickle irrigated crops. *Fert. Res.* 6 : 235-255.
- Haynes, R.J., 1988. Comparison of fertigation with broadcast applications of urea-N on levels of available soil nutrients and on growth and yield of trickle irrigated peppers. *Scientia Hort.*, 35 : 189-198.
- Horton, R., Beese, F. and Wierenger, P.J., 1982, Physiological response of Chile pepper to trickle irrigation. *Agron.J.*, 74 : 551-555 .
- Isobe, M., 1974, Investigations in Sugarcane fertilization by drip irrigation in Hawaii. P. 405-410. In *Proc. 2nd Intl. Drip Irrign. Cong.*, San Diego, California.
- Jackson, M.L., 1967, *Soil chemical Analysis*, Prentice Hall of India Pvt. Ltd., New Delhi. P. 498.
- Jahdavi, S.S., Gutal, G.B. and Chougule, A.A., 1990, Cost economics of the drip irrigation system for tomato crop. *Proc XI Int. Cong. on the use of plastics in Agric.*, New Delhi. pp. 171-176.

Fertilizer management for vegetable capsicum.

- ✓ Joshi, M.C. and Singh, D.P., 1975, *Indian Horticulture*, 20 : 19-21.
- ✓ Kataria, D.P. and Michael, A.M., 1990, comparative study of drip and furrow irrigation methods. *Proc XI Int. Cong. On the use of plastics in Agric.*, New Delhi, OP. B. 19-27.
- ✓ Keng, J.C.W., and Lugo-Lopez, M.A., 1979, Fertilizer management with drip irrigation in an Oxisol. *Agron. J.* 71: 971-980.
- ✓ Kudarimani, H.B., 1977, Study on drip irrigation under Dharwad agro-climatic conditions, *Msc. Thesis*, University of Agricultural sciences. Bangalore.
- ✓ Madramootoo, C.A. and Rigby, M., 1989. Increasing Vegetable production with trickle irrigation. *Agricultural Engineering. Proc Of 11th international congress on agricultural engineering.* Dublin, Ireland. 4-8 September, 1989. 645-652.
- ✓ Magen, H., 1995, Fertigation : An overview of some practical aspects. *Fert. News*, 40 : 12, 97-100.
- ✓ Marchesi, G. and Cattivelli, F., 1988. A comparison of different substrates, with or without fertilizer for the production of capsicum and aubergine seedlings. *Culture-Protete*, 17:1, 91-93.
- ✓ Martinez-Canadas, M.A., Martinez-Sanchez, F., Sevilla, F. and Alcaraz, C.F., 1985. Leaf development of sweet pepper growing in a green house. *Anales de Edafologica Agrobiologica*, 44(5/6) : 873-888.
- ✓ Martinez-Hernandez, J.J., Bar-Yosef, B. and Kafkafi, V., 1991, Effect of surface and subsurface drip fertigation on sweet corn rooting, uptake, dry matter production and yield. *Irrgn. Sci.*, 12 : 3, 153-159.
- ✓ Mc Laren, R.G., and Williams J.G., 1981, Effects of adding chelated and non-chelated copper and cobalt to a deficient soil on the content of these nutrients in Clover and rye-grass. *J. Sci. Food Agric.*, 32, 181-186.
- ✓ Mikkelsen, R.L., 1989, Phosphorus fertilization through drip irrigation. *J. Production Agril.* 2 : 3, 279-286.
- ✓ Mitchell, G.A., Young, J.R. (ed.) and Sumner, D.R., 1982, Fertigation for crop production in the Georgia coastal Plain. *Proc. Second National Symposium on Chemigation.* 11-17.
- ✓ Moll, J., 1996, Financial analysis of new vineyard developments in the MIA. *Technical memorandum*, 96(3) : 32.
- ✓ Muhr, G.R., Datta, N.P., Shankarasubramoney, H. and Donahue, R.L., 1965, *Soil testing in India*, United States Agency for International Development Mission to India (USAID), New Delhi. P 120.

U. A. S.
University Library
DHARWAD.

Acc No

- ✓ Muirhead, W.A., Melhuish, F.M. and White, R.J.G., 1985, Comparison of several nitrogen fertilizers applied in surface irrigation systems. I. Crop response, *Fert. Res.*, **2** : 97-109.
- ✓ Narayanan, T.A., 1991, Studies on efficiency of drip irrigation in sweet pepper. *M.Sc (Agri.) thesis*, University of Agricultural Sciences, Bangalore.
- ✓ NCPA (National committee on the use of Plastics in Agriculture), 1990, *Status, potential and approach for adoption of drip and sprinkler irrigation system*, Pune.
- ✓ O' Sullivan, J., 1979, Response to irrigation and nitrogen. *Can. J. Plant Sci.*, **59**: 1085-1091.
- ✓ Olsen, J.K., Lyons, P.J. and Kelly, M.M., 1993, Nitrogen uptake and utilization by bell pepper in subtropical Australia, *J. Pl. Nutrition*, **16** : 1, 177-193.
- ✓ Papadopoulos, I., 1985, Constant feeding of field grown tomatoes irrigated with sulfate water, *Plant and Soil*. **88** : 231-236.
- Papadopoulos, I., 1986, Nitrogen fertigation of green house grown cucumber, *Plant and Soil*. **93** : 87-93.
- ✓ Papadopoulos, I., 1988, Nitrogen fertigation of trickle irrigated potato. *Fert. Res.*, **31** : 9-13.
- ✓ Papadopoulos, I., 1992, Phosphorus fertigation of trickle irrigated potato, *Fert. Res.*, **31**:9-13.
- ✓ Papadopoulos, I., 1996, In : Shivashankar, K.(ed), Micro-irrigation and Fertigation. *Proc National Workshop on Micro-Irrigation and Fertigation*, 21-22, September, 1995, Bangalore, India.
- ✓ Papadopoulos, I. and Stylianou, Y., 1991, Trickle irrigation of sunflower with municipal water. *Agril. Water Mng.*, **19** : 1, 67-68
- ✓ Paryea, F.J., 1992, Fertigation in Washington orchards liquid nitrogen fertilizers, Washington State Horticultural Association. *Proc of the 88th Annual Meeting*, Yakima, Washington, USA, 7-9th December, 1992, 289-291.
- ✓ Payero, J.O., Bhangoo, M.S. and Steiner, J.J., 1990, Nitrogen fertilizer management practices to enhance seed production by 'Anaheim Chilli' peppers. *J. Am. Soc. Hort. Sci.*, **115** : 2, 245-251.
- ✓ Phene, C.J., Davis, K.R., Hutmacher, R.B., Bar-Yosef, B., Meek, D.W. and Misaki, J., 1991, Effect of high high frequency surface and subsurface drip irrigation on root distribution of sweet corn. *Irrigation Sci.*, **12** : 3, 135-140.
- ✓ Piper, C.S., 1966, *Soil and Plant Analysis*. Hans Publications, Bombay, p. 236.

- Proebsting, E.L., Jr., Middleton, J.E. and Mahan, M.O., 1977. Performance of bearing cherry and prune trees under very low irrigation rates. *J. Am. Soc Hort. Sci.*, 106 (2) : 243-246.
- Ramamurthy, V., 1988, Studies on chilli-Finger millet intercropping after cowpea. *M.Sc(Agri) thesis*, University of Agricultural Sciences, Bangalore.
- Ramesh, S., 1986. A study on drip and furrow methods of irrigation in green chilli under different planting patterns and plant densities, *M.Sc(Agri) thesis*, University of Agricultural Sciences, Bangalore.
- Rehm, G.W., Young, J.R. (ed.), Sumner, D.R., 1982, Fertigation of corn in the eastern Great Plains. *Proc Second National Symposium on Chemigation*. 4-10.
- Sabina Aiyana, 1995, Fertigation studies in Geranium, *M.Sc(Hort.) thesis*, University of Agricultural Sciences, Bangalore.
- Sadykov, I.M. and Mikhel, Zu. Yu, 1981. Irrigation regime in direct-sown capsicum. *Trudy kuban*, 197/275 : 114-115. *Hort. Abstr.*, 5(8) : 5473.
- Sagiv, B., Bar-Yosef, B., Kafkafi, V., and Mini, A., 1978, Fertilization and manuring of sprinkler-irrigated fields of pepper compared with fertilization via trickle irrigation system. *Inst. of soils and water*. No. 763, pp.48.
- Sestak, Z., Catask. And Jarvis, P.G., 1971, *Plant Phosynthetic Production: Manual of methods*. Ed. Junk, N.V. The Hague Publishers,.. p 818
- Shivashankar, K., 1996 (ed.). Micro-Irrigation and Fertigation. *Proc. National Workshop on Micro-Irrigation and Fertigation*, 21-22 September, 1995, Bangalore, India.
- *Sirjacobs, M. and Dada, O.S. 1983. Localized irrigation of green pepper crop in a greenhouse in an arid region. Practical approach to the management of the water supply. *Bull. Des. Recherches Agronomiques de Gembloux*. 18 : 137-148.
- Sivanappan, R.K., 1996, Status on the use of Micro-Irrigation System in crop production. In: Shivashankar, K. (ed.), *Micro-Irrigation and Fertigation, Proc. of National Workshop on Micro-Irrigation and Fertigation*, 21-22 September, 1995, Bangalore, India, 16-25.
- Smith, C.J., Freney, J.R., Chalk, P.M., Galbally, I.E., McKenney, D.J. and Cai, G.X., 1988, Fate of urea nitrogen applied in solution in furrows to sunflowers growing on a red-brown earth : Transformations, Losses and Plant uptake. *Aust. J. Agric. Res.*, 39 : 793-806.
- Srinivas, K., 1986, Studies on response of watermelon to drip and furrow irrigation in relation to plant population, *Ph. D. thesis*, University of Agricultural Sciences, Bangalore.
- *Steduts, P., 1984, Fertigation. *Rivista-di-Agronomica* 18 :1. 3-20.

- ✓ Storlie, C.A., Neary, P.E. and Paterson, J.W., 1995, Fertilizing drip irrigated bell peppers grown on loamy sand soil. *Hort Tech.*, 5 : 4, 291-294.
- ✓ Tropea, M., Fisichella, G. and Longo, A., 1982, The effect of fertigation on the mineral nutrition and yield of sweet pepper. *Tecnica-Agricola*, 34 : 3, 219-233.
- ✓ Vasantha Kumar, G.K., 1984, Efficiency and adoption of drip irrigation in cultivation of tomato. *Ph.D. thesis*, University of Agricultural Sciences, Bangalore.
- ✓ Vivekandan, A.S., Gunasena, H.P.M and Sivagnanam, T., 1972, Statistical evaluation of the techniques used in the estimation of leaf area of crop plants. *Ind. J Agric. Sci.*, 42 :857-860,
- ✓ Virender Singh, 1996, Fertigation studies with major and micronutrients in Geranium. *M.Sc.(Agri.) thesis*, University of Agricultural Sciences, Bangalore.
- ✓ Watson, D.J., 1952, The physiological basis of variation in yield. *Adv. Agron.*, 4 : 101-144.
- ✓ Watts, D.G. and Schepers, J.S., 1995, Fertigation to reduce nitrate contamination of ground water – clean environment – 21st century : team agriculture- working to protect water resources. Vol. 2 : nutrients. *Proc Kansas City. Missouri, USA, 5-8 March, 1995*, 239-242.
- ✓ Watts, D.G., Ostermeier, K.A., Eisenhaver, D.E., Norton, M.J. and Schepers, J.S., 1994, Fertigation by surge irrigation on blocked – end furrows. *Paper Am. Soc. Agril. Engineers*. No 94201, 17 pp.
- ✓ Young, R.D. and Hargett, N.L., 1984, In : *Fluid fertilizer* J.M. Potts (eds) Tennessee Valley Authority (TVA) Bull. Y-185.

*Original not seen