

**PLANNING AND DESIGNING OF SOIL AND WATER
CONSERVATION STRUCTURES IN DAPOLI TEHSIL
USING REMOTE SENSING AND GIS**

A Thesis submitted to the

**DR. BALASAHEB SAWANT KONKAN KRISHI VIDYAPEETH
DAPOLI - 415 712
Maharashtra State (India)**

**In the partial fulfillment of the requirements for the degree
of**

**MASTER OF TECHNOLOGY
(AGRICULTURAL ENGINEERING)**

**in
SOIL AND WATER CONSERVATION ENGINEERING**

**by
Miss DARA ROOHA BLESSY
(ENDPM 2019/165)**



**DEPARTMENT OF SOIL AND WATER CONSERVATION ENGINEERING
COLLEGE OF AGRICULTURAL ENGINEERING AND TECHNOLOGY
DR. BALASAHEB SAWANT KONKAN KRISHI VIDYAPEETH
DAPOLI- 415 712, DIST. RATNAGIRI, M. S. (INDIA)
September, 2021**

**PLANNING AND DESIGNING OF SOIL AND WATER
CONSERVATION STRUCTURES IN DAPOLI TEHSIL
USING REMOTE SENSING AND GIS**

A Thesis submitted to

**DR. BALASAHEB SAWANT KONKAN KRISHI VIDYAPEETH
DAPOLI - 415 712
Maharashtra State (India)**

**In the partial fulfillment of the requirements for the degree
of
MASTER OF TECHNOLOGY
(AGRICULTURAL ENGINEERING)
in
SOIL AND WATER CONSERVATION ENGINEERING
by
Miss Dara Rooha Blessy
(ENDP/PM 2019/165)**

Approved by the advisory committee



Dr. B.L. Ayare

Chairman and Research Guide
Professor & Head

Department of Soil and Water Conservation Engineering,
College of Agricultural Engineering and
Technology, Dapoli.

Members



Dr. H.N. Bhange

Assistant Professor,
Department of Soil and Water
Conservation Engineering,
College of Agricultural
Engineering and Technology,
Dapoli.

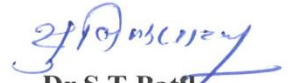

Dr. S.T. Patil

Assistant Professor,
Department of Irrigation and
Drainage Engineering,
College of Agricultural Engineering
and Technology, Dapoli.



Dr. P.R. Kolhe

Associate Professor, (CAS)
Department of Soil and Water
Conservation Engineering,
College of Agricultural Engineering
and Technology, Dapoli.

CANDIDATE'S DECLARATION

I hereby declare that this thesis or part thereof has not been submitted
by me or any other person to any other
University or Institute
For a Degree or
Diploma

Place: Dapoli
Dated: 29/09/2021

(Dara Rooha Blessy)
ENDPM 2019/165

Dr. B. L. Ayare
M. Tech., Ph.D. (SWCE)
Chairman and Research Guide,
Professor (CAS),
Department of Soil and Water Conservation Engineering,
College of Agricultural Engineering and Technology,
Dr. Balasaheb Sawant Konkan Krishi Vidyapeeth,
Dapoli- 415 712, Dist. Ratnagiri,
Maharashtra, India.

CERTIFICATE-I

This is to certify that the thesis entitled "**Planning and designing of Soil and Water Conservation structures in Dapoli Tehsil using Remote Sensing and GIS**" submitted to Faculty of Agricultural Engineering, Dr. Balasaheb Sawant Konkan Krishi Vidyapeeth, Dapoli, Dist.-Ratnagiri, (Maharashtra State) in the partial fulfilment of the requirements for the award of the degree of **Master of Technology (Agricultural Engineering)** in **Soil and Water Conservation Engineering**, embodies the results of bonafide research work carried out by **Miss Dara Rooha Blessy (ENDPM 2019/165)** under my guidance and supervision. No part of the thesis has been submitted for any other degree, diploma or publication in any other form.

The assistance and help received during the course of this investigation and source of the literature have been duly acknowledged.

Place: Dapoli
Dated: 29/09/2021

Dr. B.L. Ayare

Dr. B. L. Ayare

M. Tech., Ph. D (SWCE)

Professor and Head,

Department of Soil and Water Conservation Engineering,

College of Agricultural Engineering and Technology,

Dr. Balasaheb Sawant Konkan Krishi Vidyapeeth,

Dapoli- 415 712, Dist. Ratnagiri,

Maharashtra, India.

CERTIFICATE-II

This is to certify that the thesis entitled "**Planning and designing of Soil and Water Conservation structures in Dapoli Tehsil using Remote Sensing and GIS**" submitted to Faculty of Agricultural Engineering, Dr. Balasaheb Sawant Konkan Krishi Vidyapeeth, Dapoli, Dist.-Ratnagiri, (Maharashtra State) in the partial fulfilment of the requirements for the award of **Master of Technology (Agricultural Engineering)** in **Soil and Water Conservation Engineering**, embodies the results of bonafied research work carried out by **Miss Dara Rooha Blessy (ENDPM 2019/165)** under the guidance and supervision of **Dr. B.L. Ayare**, Professor and Head, Department of Soil and Water Conservation Engineering, College of Agricultural Engineering and Technology, Dr. Balasaheb Sawant Konkan Krishi Vidyapeeth, Dapoli and no part of the thesis has been submitted for any other degree, diploma or publication in any other form.

The assistance and help received during the course of this investigation and source of the literature have been duly acknowledged.

Place: Dapoli

Dated: 29/09/2021

Dr. B.L. Ayare

Dr. Y. P. Khandetod

B.Tech. (Agril. Engg.), M. Tech. (P.H.E.), Ph.D. (AGFE)

Dean,

Faculty of Agricultural Engineering,

Dr. Balasaheb Sawant Konkan Krishi Vidyapeeth,

Dapoli- 415 712, Dist. Ratnagiri,

Maharashtra, India.

CERTIFICATE-III

This is to certify that the thesis entitled "**Planning and designing of Soil and Water Conservation structures in Dapoli Tehsil using Remote Sensing and GIS**" submitted to Faculty of Agricultural Engineering, Dr.Balasaheb Sawant Konkan Krishi Vidyapeeth, Dapoli, Dist.-Ratnagiri, (Maharashtra State) in the partial fulfilment of the requirements for the award of the degree of Master of Technology (Agricultural Engineering) in Soil and Water Conservation Engineering is a record of bonafide research work carried out by **Miss Dara Rooha Blessy (ENDPM 2019/165)** under the guidance and supervision of **Dr.B.L.Ayare**, Professor and Head, Department of Soil and Water Conservation Engineering, College of Agricultural Engineering and Technology, Dr.Balasaheb Sawant Konkan Krishi Vidyapeeth, Dapoli, Dist. Ratnagiri. No part of the thesis has been submitted for any other degree, diploma or publication in any other form.

The assistance and help received during the course of this investigation and source of the literature have been duly acknowledged.

Place: Dapoli

Dated:29/09/2021

(Y.P.Khandetod)

ACKNOWLEDGEMENT

This is a pleasure to glance back and recall the path one travels during the days of hard and stress. It is still great at this moment to recall all the faces and spirits in the form of teachers, friends, near and dear ones. I take this opportunity to express my deep sense of gratitude to loving God for His grace, strength and blessings that He poured on me to accomplish my work and for all the things which I made today.

*At this moment of accomplishment, I would like to express heartfelt gratitude to my major advisor **Dr. B. L. Ayare**, Professor and Head, Department of Soil and Water Conservation Engineering, CAET, Dapoli, Maharashtra. I consider myself lucky to have worked under the guidance of the knowledge hungry, excellence pursuing and ever helpful personality. I am very thankful for his untiring commitment, for his efficient guidance, constant encouragement and above all the love and affection offered to me during the course of my research work. I just find it difficult to forget the ease with which he could include the confidence and optimism in me through the media of his looks, without which this would have far from reality.*

*I mention my sincere gratitude to respected **Dr. Y. P. Khandetod**, Dean, Faculty of Agricultural Engineering, Dr. Balasaheb Sawant Konkan Krishi Vidyapeeth, Dapoli who gave me an opportunity for undergoing this research work providing necessary facilities for whenever needed.*

*I express my special thanks to **Dr. H. N. Bhange**, Assistant Professor, Department of Soil and Water Conservation Engineering for his valuable suggestions and guidance for research work. I wish to express my profound sense of gratitude to **Dr. S. T. Patil**, Assistant Professor, Department of Irrigation and Drainage Engineering and **Dr. P. R. Kolhe**, Associate Professor (CAS), Department of Soil and Water conservation Engineering for his valuable help, inspiration, and constant interest in this project work.*

*I extend my special thanks to **Mr. Balasaheb B. Bodkhe**, Remote Sensing and GIS Associate, MRSAC, Pune for stimulating guidance, inspiring discussion, constructive suggestions, keen interest and encouragement during the entire research work.*

I will always recall with pride the Department of Soil and Water Conservation Engineering, College of Agricultural Engineering and Technology, Dapoli, with all the staff members for their co-operation and assistance during the course of investigation.

I placed on record my deep sense of gratitude to all my course teachers and scientists of the College of Agricultural Engineering and Technology, Dapoli for their help and involvement during the course of study.

*I am very glad to express my thanks to my senior **Sanjani** and friends **Rasika, Suraj, Suvarna, Deepak, Ravi, Harini, Mayur and Vennela** that it was impossible to complete the research work without their assistance for the constant encouragement and help during my project work.*

*My biggest gratitude is owed to my beloved father **Mr. Dara Gnana Jyothi Raj** and my mother **Mrs. Machapari Swarna Latha** for their moral support, inspiration, love and patience that made this work ever possible. I would also like to thank my brother **Mr. Dara Rochis Stephen** for his immense support, strength and guidance that made this work possible.*

The acknowledgement cannot be completed without mentioning my cordial gratitude thanks to all those, who helped me knowingly or unknowingly in this study.

Place: Dapoli

Dated: 29/09/2021

(Dara Rooha Blessy)

ENDPM 2019/165

TABLE OF CONTENTS

Title		Page No.
	CANDIDATE'S DECLARATION	ii
	CERTIFICATES	iii-vi
	ACKNOWLEDGEMENT	vii-viii
	TABLE OF CONTENTS	ix-xii
	LIST OF TABLES	xiii
	LIST OF FIGURES	xiv
	LIST OF ABBREVIATIONS AND SYMBOLES	xv-xvii
	ABSTRACT	xviii-xix
I	INTRODUCTION	1-5
II	REVIEW OF LITERATURE	6-22
	2.1 Digital delineation of micro-watershed and geomorphological characteristics of micro-watershed	6
	2.2 Planning and designing of suitable sites for soil and water conservation measures	13
	2.3 Estimation of water budget	21
III	MATERIALS AND METHODS	23-45
	3.1 Study area	23
	3.1.1 Location	23
	3.1.2 Climate	23
	3.2 Data and software used	23
	3.2.1 Data acquisition	25
	3.2.2 Development of GIS database	25
	3.2.3 Software used	26
	3.3 Digital Elevation Model (DEM)	26
	3.4 Procedure for finding stream orders in the study area	28
	3.4.1 Fill tool	28
	3.4.2 Flow direction tool	28
	3.4.3 Flow accumulation tool	28
	3.4.4 Raster calculator tool	28
	3.4.5 Stream order tool	28

		3.4.6	Stream to feature tool	29
		3.4.7	Line density tool	29
		3.4.8	Slope tool	29
	3.5	Morphometric analysis		29
		3.5.1	Linear aspects of the Watershed	29
		3.5.2	Areal aspects of the Watershed	31
		3.5.3	Relief aspects of the Watershed	33
	3.6	Land Use-Land Cover (LULC)		34
	3.7	Geology		36
	3.8	Geomorphology		36
	3.9	Lineaments		36
	3.10	Soil		37
	3.11	Rainfall		37
	3.12	Runoff depth		37
	3.13	Site suitability analysis		38
		3.13.1	Weighted overlay analysis	39
		3.13.2	Potential sites for soil and water conservation structures	39
		3.13.3	Check dam	40
		3.13.4	Percolation tank	40
		3.13.5	Farm pond with lining	41
	3.14	Estimation of water budget		42
IV	RESULTS AND DISCUSSION			46-76
	4.1	General		46
	4.2	Geomorphological characteristics		46
		4.2.1	Linear aspects of drainage network	48
			4.2.1.1 Basin Perimeter	48
			4.2.1.2 Stream order (U)	48
			4.2.1.3 Stream number	48
			4.2.1.4 Stream length (L_u)	50
			4.2.1.5 Mean stream length (L_{um})	50
			4.2.1.6 Stream length ratio (R_L)	50
			4.2.1.7 Bifurcation ratio (R_b)	51

	4.2.2	Areal aspects of drainage network	51
		4.2.2.1 Basin Area	51
		4.2.2.2 Form factor (R_f)	52
		4.2.2.3 Elongation ratio (R_e)	52
		4.2.2.4 Circulatory ratio (R_c)	52
		4.2.2.5 Drainage density (D_d)	52
		4.2.2.6 Stream frequency (F_s)	53
	4.2.3	Relief aspects of drainage network	53
		4.2.3.1 Basin relief (R)	53
		4.2.3.2 Relief ratio (R_h)	53
		4.2.3.3 Ruggedness number (R_n)	53
	4.3	Drainage density map	56
	4.4	Slope Map	57
	4.5	Contour map	58
	4.6	Geology map	59
	4.7	Geomorphology map	60
	4.8	Lineament density map	62
	4.9	Landsat 8 OLI satellite image of the study area	63
	4.10	Land use/Land Cover (LULC) Map	64
	4.11	Soil Hydrological Group map	66
	4.12	Rainfall map	68
	4.13	Runoff depth map	69
	4.14	Weighted Overlay analysis	70
	4.15	Site Suitability	72
	4.16	Potential sites for soil and water conservation structures	74
	4.17	Estimation of Water budget	76
V	SUMMARY AND CONCLUSIONS		77-78
VI	BIBLIOGRAPHY		79-85
VII	APPENDICES		86-103
	Appendix I	Calculation of Geomorphological characteristics	86
	Appendix II	Ratnagiri district annual average rainfall from 1991-2020	89

	Appendix III	Daily maximum & minimum temperature and pan evaporation data of July, 2020	90
	Appendix IV	Daily rainfall data of June, July, August, September and October of 2020	91
	Appendix V	Design of Check Dam	93
	Appendix VI	Design of Percolation Tank	95
	Appendix VII	Design of Farm Pond	99
	Appendix VIII	Values of Runoff coefficient (C)	101
	Appendix IX	Calculation of water budget	102

LIST OF TABLES

Table No.	Particulars	Page No.
3.1	Landsat 8 OLI Interpretation key	34
3.2	Decision rules for selection of suitable locations for soil and water conservation structures	37
3.3	Recommended side slope	42
4.1	Stream length, number of streams and mean stream length	50
4.2	Bifurcation ratio and stream length ratio	51
4.3	Geomorphological characteristics of the watershed	54
4.4	Area contribution of geology classes	60
4.5	Area contribution of geomorphology classes	60
4.6	Areal distribution of land use/land cover in the study area	64
4.7	Area contribution of Hydrological soil groups	66
4.8	Weight determination of different layers	71
4.9	Statistics of prioritized areas	73
4.10	Total number of different soil and water conservation structures	74

2.1.2.4

2.1.2.5

LIST OF FIGURES

Figure No.	Title	Page No.
3.1	Location map of Study Area	24
3.2	Flow chart showing the methodology adopted for identifying suitable sites for soil and water conservation measures	27
3.3	Flowchart showing the process of Maximum likelihood classification in ArcMap	35
3.4	Procedure to run SWAT model	38
4.1	Digital Elevation Model of the Study area	47
4.2	Stream order map of the study area	49
4.3	Drainage density map of the study area	56
4.4	Slope map of the study area	57
4.5	Contour map of the study area	58
4.6	Geology map of the study area	59
4.7	Geomorphology map of the study area	61
4.8	Lineament density map of the study area	62
4.9	FCC of Landsat 8 OLI	63
4.10	Land use/Land cover map of the study area	65
4.11	Hydrological soil group map of the study area	67
4.12	Rainfall map of the study area	68
4.13	Runoff depth map of the study area	69
4.14	Site suitability for implementing soil and water conservation structures in the study area	72
4.15	Optimal locations for soil and water conservation structures	75

LIST OF ABBREVIATIONS AND SYMBOLS

Abbreviations	Meaning
DBSKKV	Dr. Balasaheb Sawant Konkan Krishi Vidyapeeth
USDA	United States Department of Agriculture
SWCE	Soil and Water Conservation Engineering
ASTER	Advanced Spaceborne Thermal Emission and Reflection Radiometer
DEM	Digital Elevation Model
GIS	Geographical Information System
IRS	Indian Remote Sensing
N	North
E	East
TM	Thematic Mapper
USGS	United States Geological Survey
SRTM	Shuttle Radar Topography Mission
LISS	Linear Image Self Scanning
PAN	Panchromatic
CCT	Continuous Contour Trenches
SCS	Soil Conservation Service
CN	Curve Number
AMC	Antecedent Moisture Content
RMS	Root Mean Square
LULC	Land Use Land Cover

MCDA	Multi-Criteria Decision Analysis
NBSS & LUP	National Bureau of Soil Science & Land Use Planning
USLE	Universal Soil Loss Equation
DTM	Digital Terrain Model
LIDAR	Light Detecting and Ranging
IfSAR/InSAR	Interferometric Synthetic Aperture Radar
ISRO	Indian Space Research Organization
AoI	Area of Interest
ESDAC	European Soil Data Center
IMSD	Integrated Mission for Sustainable Development
OLI	Operational Land Imager
TIRS	Thermal Infrared Sensor (TIRS)
M ha	Million hectares
TIN	Triangular Irregular Network
ESRI	Environmental Systems Research Institute
km ²	Square Kilometer
m ²	Square Meter
yr	Year
ha	Hectares
Hr	Hour
i.e.	Id est (that is)
%	Per cent

<	Less than
>	Greater than
Π	Pi
°C	Degree centigrade
<i>et. al.</i>	Et al (and others)
t	tonnes
m	meter
mm	Millimeter
km	Kilometer
etc	Etcetera

ABSTRACT

"PLANNING AND DESIGNING OF SOIL AND WATER CONSERVATION STRUCTURES IN DAPOLI TEHSIL USING REMOTE SENSING AND GIS"

by

Miss Dara Rooha Blessy

Department of Soil and Water Conservation Engineering,

College of Agricultural Engineering and Technology,

Dr. Balasaheb Sawant Konkan Krishi Vidyapeeth, Dapoli

Dist.- Ratnagiri, Maharashtra

2021

Research Guide : Dr.B.L.Ayare

Department : Soil and Water Conservation Engineering

Soil and water are two important natural resources and basic need for agricultural production. Though the nature has been gifting us with modest amount of soil and rainfall, the unscientific management of these resources leads to scarcity in several parts of the country. Therefore, efficient management of soil and water has to be performed by planning and designing suitable structures at appropriate locations. In recent times, Remote sensing and GIS have gained higher attention in water resource planning and management. Thus, a study was conducted in Dapoli tehsil of Ratnagiri district in Maharashtra, India to calculate the geomorphological characteristics and to plan, locate and design soil and water conservation structures using remote sensing and GIS. Thematic maps like land use/land cover, stream order, slope, soil, lineament, geomorphology and runoff were mapped and analyzed through weighted overlay analysis in GIS environment to obtain suitable locations for conservation structures. Water budget calculation was also done to find out the inflows and outflows. The study resulted in reflection of 120 potential sites for designing soil and water conservation storage structures in the study area which comprises check dams 71 in number followed by farm ponds with lining 36 in number and percolation tank 13 in number. Therefore, the study was found to be successful in

demonstrating the use of remote sensing and GIS for locating suitable soil and water conservation structures at watershed level.

I. INTRODUCTION

2.2 General

The most important natural resources are air, water and soil without which human life cannot survive. All living things need land, water, air and energy. Biodiversity of an area mainly depends on the availability and quality of air, water and soil. As the population is increasing at a frightening rate, the consumption of natural resources is also increasing. Hence, there is a need for these resources to be conserved to maintain the ecological balance and save them for future ages. Conservation of nature means taking care and protecting these resources so that they continue to be available in abundance. The word conservation came into use in the late 19th century and referred to the management, mainly for economic reasons of such valuable resources as topsoil, waterbodies, pasture land, minerals and also preservation of forests, wilderness and watershed areas.

Soil and water are two important natural resources and basic need for agricultural production. The presence of water is needed for all the life on Earth including lives of plants and organisms in the soil. According to Dr.H.H.Bennett, “soil without water is a desert and water without soil is useless” (Dipika *et al.*, 2014). Water is very essential to life, yet millions of people are living in scarcity of water. India receives good amount of rainfall (1190 mm), but due to enhanced need for domestic, industrial and agriculture activities, over-exploitation of water resources, it becomes scare (Manivannan *et al.*, 2017). In January 2020, the World Economic Forum announced that, the water crisis is the global risk in terms of impact to society. As per the World Health Organization facts, 785 million people lack even a basic drinking water service, including 144 million people who are dependent on surface water. Globally, at least 2 billion people are using drinking water source contaminated with faeces. Few studies said that by 2025, half of the world’s population will be living in water-stressed areas. About 71% of the Earth’s surface is water-covered, of which the oceans hold about 97% of all the Earth’s water whereas 2.5% of Earth’s freshwater is unavailable and 0.5% of Earth’s water is available for life to survive. Breaking the percentage of freshwater of 2.5%, out of which 68.7% is locked up as ice and in the ground. Only a little more than 1.2% of all freshwater is surface water, which serves most of the lives needs. Breakdown of the surface freshwater shows that

most of this is locked up as ice, and another 20.9% is found in lakes. Rivers make up to 0.49% of surface freshwater. Although rivers account for only a small amount of freshwater, this is where we humans get a large portion of our water from.

Soil is the backbone of our food security and is our life support system. They store water for plants. Soil helps to regulate Earth's temperature. The major threat to soil is the accelerated erosion. The harmful impacts of accelerated soil erosion processes are caused by deforestation, overgrazing, tillage and unsuitable agricultural practices. The global average soil erosion rate is 2.4 t/ha/yr and the average country discontinuity is at 1.4 t/ha/yr. Soil erosion can be mitigated using sustainable land management techniques. The fertile top soil must be protected which if drains will reduce the content of minerals and nutrients of the land which may affect the agricultural production.

In India, soil degradation is estimated to be 147 million hectares (Mha) of land, including 94 Mha from water erosion, 16 Mha from flooding, 9 Mha from wind erosion, 6 Mha from salinity and 7 Mha from combination of factors. This is extremely serious issue because, India supports 18% of the world's human population and 15% of the world's livestock population but has only 2.4% of the world's land area (Ranjan *et al.*, 2015). Land use change is driving land degradation such as soil erosion, nutrient depletion, salinity, water scarcity, pollution, disruption of biological cycles and loss of biodiversity. This affects people's livelihoods by threatening their food and water supply, lowering the quality of their environment, decreasing biodiversity, etc. To address these challenges, sustainable land management offers a range of interventions to prevent or reduce land degradation in the country.

Various approaches have been adopted and experimented to halt the process of degradation of these resources. Of late, watershed approach has been considered appropriate to reduce the face of degradation and improve the process of development and conservation of land, water and vegetation in an integrated manner. As watershed support the entire dryland agriculture, the strength of the watershed development programs can only be accessed through the growth of agriculture as one of the key factors. The conservation, development and management of the land resources which ensures the chemical, physical and biological health of soil profile are of prime importance. During the last century it has been observed that the pressure of increasing population tremendously has led to degradation of these natural resources.

2.3 Land Use Classification in India

The total geographical area of the country is 328.73 Mha. The net sown area during different cropping season was estimated as 140.13 Mha constituting 45.5% of the total geographical area. Amongst the other prominent land use/land cover classes the area under forest cover has been found to be 79.79 Mha constituting 23.3% of the total geographical area of the country. The net irrigated area and gross irrigated area of the country are 68.38 Mha and 96.46 Mha respectively (Rajini *et al.*, 2020).

2.4 Soil and Water Conservation Structures

Soil and water conservation are the activities at the local level which maintain or enhance the productive capacity of the land including soil, water and vegetation in areas prone to degradation through conservation or drainage of water, maintenance or improvement of soil fertility, and prevention or reduction of soil erosion, compaction, salinity. Soil and water conservation are an integral part of watershed management. The watershed management aims to balance the development within a watershed. It is the analysis, protection, repair, utilization, and maintenance of drainage basin for optimum control and conservation of water with due regard to other resources such as vegetation, biodiversity, etc.

Planning and design of soil and water conservation structures such as check dams, waterways, terraces and bunds, gully control structures, water harvesting structures, etc. are the major interventions in the development of a watershed. This development is not just confined to agricultural lands but covers the entire watershed area starting from the highest point to the outlet of natural streams. Soil and water conservation practices very rightly receive top priority for planning watershed management as they act as a foundation for sustainable rainfed agriculture. The main aim is maximum amount of rainfall is effectively utilized and conserved in the watershed.

2.5 Remote Sensing and GIS

Remote sensing is the acquisition of information about an object by a recording device that is not in physical contact with the object. Satellite remote sensing has begun in 1960s by attaching cameras and sensors to the spacecrafts. Today, this term is generally used to describe the process of collecting, viewing,

interpreting, and analyzing aerial or satellite-based images. The field of remote sensing evolved from the interpretation of aerial photographs to the analysis of satellite images, and from local area studies to global analysis with the advances in sensor system technologies and digital computing. In the last 3 decades, the technologies and methods of remote sensing have evolved dramatically to include a suite of sensors operating at a broad range of imaging scales with potential interest and importance to planners and land managers. Coupled with the ready availability of historical remote sensing data, the cost reduction, and increased resolution from satellite platforms, remote sensing technology appears poised to make a greater impact on planning agencies and land management initiatives. Remote sensing data is extremely accepted and used for various hydrological studies. The Digital Elevation Model (DEM) is an important data product which represents the altitude of earth's surface. It helps to generate contours, drainage network analysis, runoff and soil erosion analysis, design of hydraulic structures, watershed planning, etc.

GIS is an acronym for Geographical Information System. GIS is a multi-component environment used to create, manage, visualize and analyze data and can be considered as an extension of cartography. It is a computer-based tool for mapping and analyzing data. GIS provides digital representation of the watershed characterization used in the hydrological modelling. During the systematic survey of watershed factors like soil, vegetation, land use, slope, drainage pattern, etc. are considered and huge amount of attribute data is required. There are difficulties in data management using traditional methods. Presenting results through maps, charts, diagrams, texts, etc. handling of voluminous data and its storing, manipulating, retrieving and updating is cumbersome and tedious. Besides this, plenty of time is needed to manage the database. With the invention of advanced computerized technology, the above said problems are best handled through GIS techniques. Its capability to overlay multi-thematic data, which could be used in hydrological models or in integrated watershed management planning is a major advantage for sustainable development.

2.6 Justification

Dapoli is a tehsil in North Ratnagiri district of Maharashtra with an area coverage of 910.40 km². The tehsil is situated in semi-humid to humid zone with weather conditions of moderate hot in summer to extreme cold in winter with

constant humidity as it is located in the coastal region. It is situated in the foothills of Western Ghats. This region is characterized by high rainfall intensity and runoff. Due to the undulating and rocky topography in the region, most of the rainfall is lost as runoff and this causes severe water scarcity in the region in summer months.

Therefore, this study is an attempt to plan and design appropriate soil and water conservation structures either to store water in different structures or to recharge the groundwater for future use. Huge expenses and labor involved in field visits will be saved by integrating Remote Sensing and GIS in this approach.

2.7 Objectives

1. To determine the geomorphological characteristics of micro watershed.
2. To plan, suggest and design suitable soil and water conservation structures.
3. To estimate water budget using soil and water conservation measures.

II. REVIEW OF LITERATURE

Various scientists have attempted to plan and design conservation measures in the watershed through vivid approaches. To gain some knowledge from the previous works, an attempt has been made in this chapter to review some of the past works on digital delineation of watershed, geomorphological characteristics, land use/land cover, identifying different sites for soil and water conservation structures by analytical hierarchy process, weighted overlay analysis and water budget calculation.

1. Geomorphological characteristics of the watershed

Gowd (2004) analyzed morphometric and related parameters for Peddavanka basin, Anantapur district, Andhra Pradesh. The results showed that the basin was of 6th order having dendritic drainage pattern sloping from 0 to 17°. The length of basin decreases as the order of stream increases and it was lowest in case of highest stream orders. Elongation ratio was 0.45 showing extremely elongated nature. The mean bifurcation ratio lies between 3 & 5 which indicated the homogeneous character and geologic structure with mature topography.

Nookaratnam *et al.* (2005) made an attempt for positioning check dam by prioritization of micro-watershed using SYI model and morphometric analysis using Remote Sensing and GIS. Morphometric parameters such as drainage density, bifurcation ratio, texture ratio, length of over land flow, compactness coefficient, stream frequency, elongation ratio, circulatory ratio, shape factor and form factor were computed. Automated demarcation of prioritization of watershed was done by using GIS overlaying technique by assigning weight factors to all the identified features in each thematic map and ranks were assigned to the parameters. 5 categories of priority i.e., very high, high, medium, low and very low were given to all the watersheds. 62 watersheds using SYI method and 23 watersheds using morphometric data were prioritized under very high priority. 24 suitable sites were identified for constructing check dams in 21 highly prioritized watersheds.

Rekha *et al.* (2011) evaluated and assessed morphometric analysis and micro-watershed prioritization based on water holding capacity of Peruvanthanam sub-watershed in Manimala river basin in Kerala, South India.

SOI topographical maps 58 C/14 and 58 C/15 of 1:50000 scale was digitized using ArcGIS 9.2 software. Morphometric analysis was carried out and parameters like bifurcation ratio, basin relief, relief ration, ruggedness number, drainage density, stream frequency, texture ratio, form factor, length of overland flow, constant channel maintenance were found. The analysis revealed that the stream order varied from 1 to 6 and the total number of stream segments of all orders was 347, of which the maximum area (69.16%) was covered by 1st order streams and the minimum (0.29%) by 6th order stream. The higher values of basin relief (0.9), relief ratio (0.07) and ruggedness number (3.02) (relief parameters), high values of drainage density (3.36), Stream frequency (6.15), Texture ratio (6.82), lower values of Length of overland flow (0.14) and Constant channel maintenance (0.3) (aerial parameters) revealed that the sub-watershed had a complex structure, mountainous relief, high runoff and low infiltration. The maximum area was covered by high to medium prioritized zones (19.07km²), the low to very low (17.75 km²) and very high to high zone was only 4.72 km².

Bose *et al.* (2012) delineated Kadam watershed of middle Godavari sub basin (G-5) of Godavari River basin into 18 mini watersheds using GIS and morphometric analysis has been carried out at mini watershed level. They collected the topographic sheets of 1:50,000 from Survey of India and delineated in ArcGIS 9.3 and stream lengths were found. From the study they found that circulatory ratio of 0.642 and drainage density of 3.510 have been found. The maximum values of stream frequency of 7.25 and texture ratio of 15.81 had been found. They also demonstrated that GIS is flexible and was relatively easy to apply on large areas enabling gathering of all data and information in a common data base for delineation of watershed and stream network analysis.

Gulshan and Rajeshwari (2012) delineated and found land use pattern of a sub-watershed and micro-watersheds in Mahendergargh district of Haryana in India using toposheets of scale 1:25,000 from Survey of India and multi-spectral satellite data of IRS P6. They delineated the watershed boundary using ArcGIS 9.3 software by using Arc-hydro tools. They also studied the change in land use pattern over a period of 30 years and found that agricultural land has been increased from 1629 km² to 1670 km² and the area

under waste land was 10.7% in 1976, which declined to 8.65% in 2008. The settlement area has increased, area under water has decreased from 5.11 km² to 1.83 km² due to drying of rivers and forest cover has almost remained the same.

Kuldeep and Upasana (2012) studied quantitative morphometric analysis of a watershed of Yamuna Basin, India using ASTER(DEM) data and GIS. They used ASTER data to prepare a Digital Elevation Model (DEM) in GIS and various thematic maps like drainage density, slope, relief, superimposed profile and longitudinal profiles were prepared using ArcGIS software and linear, areal and relief aspects were evaluated. About 85 morphometric parameters of all aspects were computed. From the study they found that the geomorphometric analysis was very useful for planning rainwater harvesting and watershed management.

Aravinda and Balakrishna (2013) performed the morphometric analysis of Vrishabhavathi watershed of the Arkavathi river basin, Bangalore Urban and Ramanagara districts of Karnataka. They achieved this morphometric analysis from toposheets of scale 1:50,000 from Survey of India and with the help of GIS tools they determined the linear, aerial and relief aspects of the watershed. From the drainage map of the study area dendritic drainage pattern was identified having drainage density of 1.697 km/km² and stream order was calculated using Strahler (1964) stream ordering method.

Kailash *et al.* (2013) evaluated geomorphological characteristics of Varuna Watershed using GIS and Remote Sensing techniques in Varuna River watershed of Uttar Pradesh, India using ArcGIS and ERDAS Imagine software. SOI toposheets in the scale of 1:50,000 was used to map the boundary of the watershed, stream network and contours. For ordering the river network Strahler's River ordering scheme was followed. The watershed is oblong in nature with flat topography with fourth order stream. The elevation varied from 95 m to 65 m above MSL respectively. The main features of the watershed Stream-area ratio, Bifurcation Ration, Stream-length ratio were 4.76, 4.28 and 2.4 respectively. 101 streams were there in the watershed with total stream length of 1575 km. The drainage density and stream frequency values were 0.48 km⁻¹ and 0.03 km⁻¹ respectively which resulted in low textural dissection. The low values of drainage density, stream

frequency and drainage intensity implied that the surface runoff was not quickly removed from the basin, making it susceptible to flooding.

Prafull and Jay (2013) studied morphometric analysis of Morar River basin in Madhya Pradesh, India using geospatial techniques. GIS was used for the calculation and delineation of the morphometric characteristics of the basin. The drainage network of the basin was dendritic which exhibited the homogeneity in texture and lack of structural control. The drainage density was low which indicated that the area possessed highly permeable soils and low relief. The stream orders were from 1 to 6 and bifurcation ratio varies from 2.00 to 5.50 and elongation ratio (0.327) revealed that the basin belonged to the elongated shaped basin category. The study results were useful in determining the effect of catchment characteristics such as size, shape, slope of the catchment and distribution of stream network within the catchment.

Rafiq *et al.* (2013) studied morphometric analysis of Vishav drainage basin using geo-spatial technology in Kashmir valley, India. Toposheets of 1:50,000 scale with the help of Arc-View 3.2a software. Linear aspects, areal aspects and relief aspects of the watershed were computed in GIS environment. The study showed that the drainage basin was characterized by dendritic to sub-dendritic drainage pattern. Stream segments development in the basin area was more or less affected by rainfall and snow melt off. The bifurcation ratio between different successive orders was almost constant which revealed the partial structural control. The stream frequency value of exhibited the positive correlation with the drainage density value of 2.03. the drainage density indicated that the region has permeable subsoil and relatively dense vegetation cover. The circulatory ratio and elongation ratio were 0.52 and 0.15 respectively which indicated that the drainage basin was in elongated shape, has low discharge of runoff and relatively permeable subsoil condition. The study clearly concluded that the morphometric analysis-based GIS technique was very useful to understand the prevailing geo-hydrological characteristics and for the planning and management of the watershed.

Dharmishtha and Pramendra (2014) found the morphometric analysis on the basis of toposheet of Meghnagar, Jhabua district of Madhya Pradesh using conventional method. They calculated drainage density, length of overland flow, stream frequency, elongation ratio, lemniscates, basin relief, relief ratio,

ruggedness number and 1.2151/km, 2.4305, 2.025/km², 0.9175, 0.38425, 42m, 6.095, 0.0655 were the average results respectively. The results found that the watershed is characterized by the stream order ranging from 1st to 4th order and the lower bifurcation ratio indicated less structural disturbance, length of overland flow reflected that water before reaching to drainage channel flowed to a very little distance.

Rambabu and Jai (2014) studied the watershed characteristics using Google Elevation Service near Kosigi village in Kurnool district in Andhra Pradesh, India using Open Data Archive (CartoDEM) of ISRO's Bhuvan website. Thematic maps such as watershed boundary, drainage network and contours were prepared from the DEM data using ArcMap software. An online tool using Google Maps & Elevation Service was developed to study watershed characteristics. The results showed that the basin relief which was automatically calculated was wrong due to the presence of small hills on the perimeter of the watershed. It was resolved by visual interpretation and manual calculation. Also, the study showed that the Linear, Aerial, Relief aspects of three micro-watersheds using Google Maps API was calculated with less effort and in shorter period. The shape of the watershed was near to circular and less elongated with gentle slope which will contribute more infiltration.

Bhavana (2015) studied the morphometric analysis of Andhale watershed of Pune district, Maharashtra using toposheets obtained from Survey of India and ASTER DEM data in ArcGIS software. The study calculated the linear, areal and relief aspects like main stream length, basin perimeter, length of the basin, stream order, mean stream length, sinuosity index bifurcation ratio, drainage basin, elongation ratio, infiltration number, form factor, stream frequency, circulatory ratio, drainage density, compactness coefficient, relief ratio, ruggedness number, etc. The results showed that Andhale river had been designated as a fifth order basin and drainage density values revealed that the nature of sub-surface strata was impermeable where the drainage density is greater than 5. The mean bifurcation ratio was observed as 4.65 which indicated that the watershed was less affected by structural disturbances.

Patil *et al.* (2015) assessed morphometric characteristics using Remote Sensing and GIS in Karwadi-Nandapur watershed in the Kayadhu river watershed in Marathwada region of Maharashtra, India. Remotely sensed images of the Indian Remote Sensing Satellite P6 (IRS P6) Cartosat satellites, toposheets, soil maps and Linear Imaging Self Scanner III (LISS III) were used. Using the PCI Geomatica 10.0 software the thematic maps like drainage map, Land use-land cover, soil maps and contour map were prepared. The results showed that the basin was of third order and Strahler's method was employed to assess the fluvial characteristics of the watershed. The study concluded that the morphometric properties determined for this watershed will be useful for efficient planning of water harvesting and groundwater projects on watershed basis.

Sandeep (2016) assessed the morphometric characteristics of Chakrar watershed in Madhya Pradesh using geospatial techniques using toposheets from Survey of India, ASTER data and Landsat-TM satellite imagery from USGS earth explorer. The downloaded satellite images were georeferenced with toposheets, given same coordinate system and delineated. DEM was extracted which helped to calculate the linear, areal and relief aspects of the watershed. The drainage density value indicated that the area is having moderate slope with sparse to dense vegetation, higher infiltration rate, moderate surface runoff and less dissection. The study also proved that GIS technique provided high accuracy in mapping and measuring morphometric parameters.

Hasan *et al.* (2017) calculated morphometric analysis in Gandeswari watershed of Bankura district of West Bengal state using Remote Sensing and GIS. The toposheets of scale 1:50000 were procured from Survey of India and SRTM DEM was used to calculate morphometric analysis. Basin area, perimeter, length, elongation ratio, form factor, recirculatory ratio, maximum and minimum height, ruggedness number, bifurcation ratio, stream order, drainage density, etc. were calculated. The results showed that the bifurcation ratio was less which showed the less structural disturbance and high drainage density suggested that the soil is less permeable and has high surface runoff. The stream order of the study area was 7th.

Praveen *et al.* (2017) analyzed morphometric parameters with the help of GIS in Kanhar basin in India. ASTER DEM in conjunction with remote sensing satellite data were used in the study. Stream order, stream length, drainage density, bifurcation ratio, stream frequency, circulatory ratio, form factor, etc. were calculated. The drainage pattern of the basin showed sub-dendritic to dendritic drainage pattern having drainage area of 5654 km². Seventh order stream was prevailed in the basin with drainage density value as 1.72 km/km². The study concluded that the increase in stream length ratio from lower to higher order showed that the basin has reached a mature geomorphic stage.

Rahaman *et al.* (2017) studied the morphometric analysis in Barind area of Bangladesh using toposheets obtained from Survey of Bangladesh and SRTM DEM. The study calculated stream number, stream orders, stream length, bifurcation ratio, drainage density and texture, circulatory ratio, form factor, stream frequency, elongation ratio, relief ratio, etc. The results said that the dendritic drainage pattern was not affected largely by structural disturbance, the east facing slopes of the watershed revealed the higher moisture with higher vegetation. Also, the morphometric parameters revealed that the groundwater recharge and surface water augmentation can be adopted for water resource management of the study area which help in better understanding of the drainage and basin planning and water resource management and will be useful for sustainable natural resource management.

Bansod and Ajabe (2018) determined geomorphological characteristics of Karpri-Kalu watershed in Sangamner tehsil of Ahmednagar district using GIS techniques. DEM was used to delineate the watershed and to analyze the drainage patterns of the land surface terrain. Various operations were done to prepare contour map and drainage maps and areal, linear and relief aspects of the watershed were estimated. The study determined that the 4th order stream was trunk order and stream order, stream length ratio, bifurcation ratio, basin length, length of overland flow, form factor, circulatory ratio, elongation ratio, stream frequency, drainage density, constant of channel maintenance, maximum relief, relative relief, relief ratio and ruggedness number were determined. The bifurcation ratio and form factor for the area was 3.166 and

0.424 respectively. Also, the result showed that the watershed was less elongated and poorly drained.

Gizachew and Berhan (2018) studied hydro-geomorphological characterization of Dhidhessa river basin in Ethiopia using SRTM DEM, geological and hydrological maps. The results showed that 33,468 km stream length of all orders was distributed within 28,637km² drainage area in a dendritic pattern. Drainage area was found large, drainage frequency was course, basin shape was more elongated, drainage density was medium, infiltration number was low, overland flow was long and constant of channel maintenance was high. Also, the basin's relief, relief ratio, ruggedness number, gradient ratio and the slope was high. The study also asserted that the basin was underlined by uniform resistant rocks, less prone to flooding with high water resources potential and susceptible to soil erosion.

Kudnar and Rajasekhar (2019) studied morphometric analysis and cycle of erosion in Wainganga Basin which comprised in the states of Maharashtra, Madhya Pradesh and Chhattisgarh. The topographical maps of 1:50,000 scale and Cartosat DEM were utilized for the study. The results showed that there were 6 order streams in the basin, bifurcation ratio varies from 2.97 to 9.00, elongation ratio was 0.12 which revealed that the basin is strongly elongated and it is composed of highly permeable homogeneous geologic materials. The drainage density of the river basin is 0.66. The study recommended that the river basin needs a hydrogeological and geophysical study in the future for proper water management and choice of artificial recharge structures for recharging groundwater in the area of interest.

Nanabhau and Rajasekhar (2019) studied morphometric analysis and cycle of erosion in Waiganga Basin which comprises in some parts of Maharashtra and Madhya Pradesh using SOI toposheets on a scale of 1:50,000 and CartoDEM. The linear, aerial and relief aspects of the watershed were found. The study results showed that the total number of streams were 9472. Of these 6502 were first order, 2190 were second order, 605 were third order, 153 were fourth order, 17 were fifth order and 4 were sixth order streams. The range of bifurcation ratio was 2.97 to 9.00 and average value is 3.97 and the elongation ratio was 0.12. The study reveals that the basin was strongly

elongated and it was composed of high permeable homogeneous geologic materials. The drainage density was 0.66. The study recommended that the river basin needs a hydrogeological and geophysical study in future for proper water management and artificial recharge structures for groundwater recharge.

Abhishek *et al.* (2020) studied morphometric analysis of Kakan watershed in Udaipur district of Rajasthan, India using ALOS DEM of spatial resolution 12.5 m which was used to determine stream network and slope map. The results showed that the area of the watershed was 47.44 km² and has 5th order trunk stream. The total length of the streams was 131.61 km of which 77.51 km was of 1st order, 25.03 km was of 2nd order, 15.15 km was of 3rd order, 6.58 km was of 4th order and 7.35 km was of 5th order. The results which were obtained from stream numbers and mean stream length were in accordance with the Horton's law of stream numbers and mean length. The drainage density was high (2.77 km/km²) revealed that the well-defined channel network which will produce more runoff. The elongation ratio and bifurcation ratio were 0.783 and 0.26 respectively which showed the elongated shape and youth stage of tributaries. The study concluded that it would help in planning and designing of soil and water conservation measures.

2. Site Suitability studies using Remote Sensing and GIS techniques

Anbazhagan *et al.* (2005) studied artificial recharge, runoff estimation and planning in Ayyar basin in Tamil Nadu, India. The Indian Remote Sensing satellite 1A Linear Image Self Scanning Sensor II (IRS 1A LISS II) satellite imagery, aerial photographs and geophysical resistivity data were used to prioritize suitable sites for artificial recharge and to estimate the volume of aquifer dimension. The runoff water available for artificial recharge in the basin was estimated through SCS-CN method. The land use/land cover, hydrologic soil group and rainfall data in different watershed areas were used to calculate runoff depth in the watersheds. The weighted curve number for each watershed was obtained through spatial intersection of LULC and hydrologic soil group through GeoMedia 3.0 Professional GIS software. Artificial recharge planning was derived on the basis of availability of runoff, aquifer dimension, priority areas and water table conditions in different watersheds in the basin. The volume of runoff was 110.17 m³ per annum was

available for artificial recharge in the basin. The available aquifer dimension for artificial recharge in the priority area was 4718.29 million m³.

Girish *et al.* (2008) carried their work in delineation of potential sites for water harvesting structures using geospatial techniques in Bakhar watershed of Mirzapur district in Uttar Pradesh, India. Various thematic maps such as geomorphology, lineaments, land use-land cover, geology and drainage were prepared. These layers were integrated using GIS techniques to derive suitable water harvesting sites and each of them was assigned a weightage depending on its influence on ground water recharge. Ranking of 1 to 4 was given depending on its significance in storage and transmittance of groundwater and these were multiplied with layer weightage to form score. The results showed that the average score for excellent region was greater than 200, for good 121-200, for moderate 81-121 and the other polygon having value less than 80 were assigned to poor category. Using these, the suitability sites for water harvesting structures such as Check dams, contour bunding, recharge pits, wells and contour trenches have been suggested.

Praveen and Prasad (2008) worked on integrated land and water resources conservation, management and development plan using remote sensing and GIS of Chevella sub-watershed in Rangareddy district of Andhra Pradesh. IRS P6 LISS-III, IRS 1D LISS-III and IRS 1D PAN imagery were used for the preparation of land use/land cover, hydrogeomorphology and soil maps. Topographical maps, satellite data, rainfall data, temperature data, other collateral data was procured and DEM, contour map, slope map, flow direction, flow accumulation output raster, maps along with drainage, land use/land cover, aspect and relief maps from DEM, preliminary pre-field interpretation of hydro geomorphology using satellite data on 1:25000 scale were done using ArcGIS 9.0 software. The results showed that slope was reclassified into 2 classes where class 2 was given high priority and class 1 was given least priority. The 3rd stream order raster was given high priority, 2nd order stream was given moderate priority and 1st order stream was given least priority.

Ramakrishnan *et al.* (2008) worked on delineation of potential sites for water harvesting structures through remote sensing and GIS techniques in Kali

watershed, Gujarat, India. Images of LISS-III, PAN (IRS-1D), Landsat TM and collateral data was collected and thematic layers such as land use/land cover, lithology, soils, slope, rainfall and drainage maps were generated. A potential site suitability map for water harvesting structures was derived followed by analytical hierarchy process and it was later validated in the field. The results showed that the accuracy of prediction was estimated on the basis of proximity between derived and field validated sites and in 75% of the cases, the sites derived for check dam, percolation pond and subsurface dyke were accurate.

Singh *et al.* (2008) conducted a case study to identify suitable sites for water harvesting structures in Soankhad watershed, Punjab using Remote Sensing and GIS. The IRS-1C, P6 satellite images was used. Thematic maps such as land use map, hydrological soil group map, slope map was prepared. The study showed that suitable sites were not found for nala bunding and farm ponds because of steep slopes, less soil thickness and high runoff velocity. From the study, fourteen check dams and six percolation tanks were proposed for the construction as per IMSD guidelines. The average runoff of the wet season (July-September, 1996) was 1543.82 mm and total runoff volume was estimated as 143.52 mm³.

Harshika and Ingle (2012) made an attempt to study land use land cover classification and change detection using high resolution temporal satellite data in Jalgaon District, Maharashtra, India. The satellite images of March and November of year 2007 were used for Land Use/Land Cover supervised classification. LULC was classified into 7 classes and for accuracy assessment classification error matrix and KAPPA analysis was done. The results showed that the most extensive land cover category was agriculture land i.e., 49.43% in November. The second most extensive land cover class was Barren land i.e., 28.13% in March. The major change detected in the study was in Agricultural area from pre-monsoon to post-monsoon season. The overall accuracy of classification is 89% and 91.02% and Kappa statistics was 0.86 and 0.88 respectively for march and November images.

Abhay *et al.* (2013) studied identification of water conservation sites in WRJ-2 watershed falling under Narkhed and Katol Tahsils of Nagpur district, Maharashtra using GIS techniques. The IRS 1C LISS-III geo-coded data was

digitally enhanced using Arc-Info 9.0 software and interpreted for preparation of different thematic layers like drainage, geomorphology, soil, geology, land use/land cover. These thematic maps were then converted into raster formats with spatial analysis tool and reclassified with suitable weightage which were assigned for each layer. These raster maps were assigned respective theme weightage values and were overlaid and analyzed under Arc-Info 9.0 software for evolution of water conservation. The study suggested the effective conservation structures like gully plugs, CCT, earthen dams, percolation tanks.

Praveen and Jayarama (2013) analyzed land use/ land cover changes in urban area in Tirupati region in India using Geo-spatial techniques. SOI topographic map, LISS III and PAN of IRS ID of 2003 was used for the study. The area was classified into 8 categories on the basis of field study, geographical conditions and remote sensing data. The results showed that the comparison of LU/LC in 1976 and 2003 derived from toposheet and satellite imagery interpretation indicates that there is a significant increase in built-up area, open forest, plantation and other lands. The result also concluded that substantial amount of agricultural land, water spread area and dense forest area was vanished during the period of study. The mining activities were not found in the area in 1976, but later in 2003 small mining land was found.

Bansode and Patil (2014) estimated runoff by using SCS Curve number method using ArcGIS in Khuldabad taluka of Aurangabad district in Maharashtra. Toposheets and LISS-III satellite image of the watershed were used for the study. Rainfall and Curve Number (CN) were used as inputs where CN represents the runoff potential of the land cover soil complex. The results showed that the rainfall was fluctuating in nature during the ten years period, yearly runoff of the study area from 2003 to 2012 is 430, 401, 214, 582, 279, 499, 341, 707, 271 and 135 mm respectively, minimum and maximum runoff was observed in the 2012 and 2010 respectively using SCS-CN method. The correlation coefficients for daily, monthly and yearly runoff were 0.73, 0.97 and 0.99 respectively.

Harish *et al.* (2014) studied the site suitability analysis of water harvesting structures using Remote sensing and GIS in Pisangan watershed in Ajmer district, Rajasthan. Landsat 8 images, ASTER DEM, rainfall data (2000-2012) were procured and different thematic maps like soil texture,

slope, geomorphology, lithology, lineaments, drainage network, land use/land cover were prepared. SCS model was used to estimate the runoff depth and Analytical Hierarchy Processes (AHP) was used to find the suitable water harvesting structures on the basis of rainfall. Based on the lithology, land use/landcover, slope and drainage map the appropriate water conservation structures suggested were storage tank, percolation tank, stop dam and check dam.

Chirag *et al.* (2015) estimated surface runoff for Ahmedabad Urban Area using SCS-CN method and GIS. Rainfall data of 4 rain gauge stations (1988-2012), IRS P6 LISS-IV satellite image, soil map was collected for the study. Rainfall distribution, hydrological soil group, land use/land cover maps were created and weights were assigned to different to each soil hydrologic group and corresponding land use classes. The results obtained from the study were there are 2 soil hydrologic groups B and C in the study area, land use/land cover classes were classified into agriculture, built-up area, commercial area, open space, industrial, wasteland, waterbodies and woods-grass combination having area 171.79 km², 541.74 km², 117.71 km², 91.42 km², 2.95 km², 7.79 km², 3.07 km², 9.45 km², 32.81 km², 2.41 km², 6.18 km², 14.51 km², 19.14 km², 6.13 km² and 15.23 km² respectively. The weighted CN for AMC-I was 73, AMC-II was 86 and AMC-III was 94.

Naser *et al.*, (2016) detected the land use changes in Haraz basin in Mazandaran province using Remote Sensing and GIS. The rivers, roads and DEM maps were used in software and image of each year with RMS error under one pixel were corrected. Supervised classification method and maximum likelihood algorithm were used. Training sites were selected for 9 classes in 1996 image and 11 classes in 2011 image such as residential, farming, water, horticulture and sparse forest, dense forest, first grade range, second grade range, dry farming and bare lands. The result showed that 27% of the study area has been changed and the reason is due to the population increase and human activities.

Arjita *et al.* (2017) assessed the potential sites for water harvesting and to identify suitable sites for water harvesting structures in Sojat watershed of Pali district in Rajasthan by GIS and Multi Criteria Evaluation (MCE). GIS database for decision variables and watershed characteristics was prepared at

suitable spatial resolution. The SCS-CN model was used to estimate the runoff in the watershed. Using MCE along with Analytical Hierarchy Processes (AHP) water harvesting potential sites were assessed and optimum locations of rain water harvesting structures were identified.

Khalid and Aysar (2017) worked on selecting suitable sites for water harvesting structures in a flood prone area using Remote Sensing and GIS in Ali Al Gharbi which is located in southeast part of Iraq. ASTER-GDEM data of 30 m resolution was used. Various thematic maps such as land use, drainage, hydrologic soil group and slope maps were prepared for selecting suitable locations and for constructing check dams. From the study, four check dams and four percolation tanks were proposed for construction.

Sateeshkumar *et al.* (2017) estimated rainfall-runoff using SCS-CN method and GIS approach in the Pappiredipatti watershed of Vaniyar sub basin in South India. The SCS-CN method was used for calculating volume of runoff on soil map and land use-land cover map in ArcGIS. The results showed that the CN for the watershed is 75.4 for AMC-I, 28.4 for AMC-II and 87.5 for AMC-III which proved that SCS-CN method is efficient to work, consumes less time and facility to handle large dataset and vast area to identify site selection for artificial recharge structures.

Patode *et al.* (2017) worked on planning of conservation measures for water management and development by using Remote sensing and GIS with IRS-LISS III multispectral images, SRTM data with 30 m resolution and SOI toposheet. The satellite images were processed through image processing software's like ERDAS IMAGINE and ArcMap 10.3. Various thematic maps like land use-land cover, geomorphology, geology, slope was prepared using these data. These thematic layers were integrated using GIS for development of watershed activity like recharge wells, farm ponds, gully plug, etc. The study concluded that the area has very undulating slopes towards North direction and elevations of 270 m to 480 m above mean sea level is drained by many streams. Different in-situ conservation practices and temporary, semi-permanent and permanent structures were adopted on the drainage lines for harvesting the runoff from rain water.

Arnab *et al.* (2018) identified potential sites for water harvesting structures using Geospatial techniques and multi-criteria decision analysis in

Mandi River watershed in Kanker district of Chhattisgarh, India. Satellite data was used to make LULC map, lithology map and lineament, field data such as rainfall map and soil depth were needed, SoI toposheet was needed to derive contour layer and drainage density, DEM to drive slope map were used in the study. Weights were assigned to each layer using Analytical Hierarchy Process (AHP) and with the help of Multi-Criteria Decision Analysis (MCDA) a possible site suitability map for water harvesting/conservation structures were derived. By applying Weighted overlay analysis, the water harvesting sites were identified and then water harvesting structures maps were prepared. The study results concluded that location of structure identification needs expert opinion with respect to local topography.

Mani *et al.* (2018) selected Kolleru lake which is located between Krishna and Godavari delta which comprises parts of Khammam, Krishna and West Godavari districts of Andhra Pradesh for mapping of soil erosion for soil and water conservation measures. The ASTER DEM of the catchment was downloaded and DEM, Land Use/ Land Cover map was prepared. The soil data developed by NBSS&LUP was taken and soil textural map was prepared. USLE equation was used to calculate annual soil erosion in the area of interest. The lowest and highest computed soil erosion values were 0.000248 t/ha/yr and 37.75 t/ha/yr respectively. In arable deep soils, contour bunds, graded border strips, waterways with drop structures, vegetative bunds, planting of agroforestry species and in non-arable lands gully stabilization structures like check dams and gabion structures, contour trenching and planting of forestry species were suggested.

Pande *et al.* (2018) applied remote sensing and GIS in planning and management of Purna watershed in Akola district of Maharashtra. The topographical maps were collected from Survey of India and SRTM data was used to create DEM in ArcGIS 10.3 software using Arc Hydro tools with reference to toposheet. The slope map and aspect maps were prepared from flow direction map, flow accumulation map and several thematic maps were created. The results obtained from slope analysis said that the slope category of 0-94.32% and 94.32-154% had low runoff, 154-215.51% had moderate runoff and 215.51-359.73% had high runoff in the Purna watershed. The

results concluded that a good quality perspective was done for understanding the problems of water conservation management and development using remote sensing and GIS.

Tushar *et al.* (2018) performed site suitability analysis for establishing soil and water conservation structures using Geoinformatics in Chinnar watershed which is located in Dharmapuri and Krishnagiri districts of Tamil Nadu in India. Thematic layers such as runoff, slope, land use-land cover, lineament, drainage density, soil texture and geomorphology were used which were generated with the help of remote sensing images and further integrated using weighted overlay techniques in GIS environment to derive suitable sites for soil and water conservation structures. The results shown that only less than 1% area is highly suitable, about 34% of the study area is moderately suitable and about 65% area is less suitable for implementing soil and water conservation structures. Based on these site suitability results and topographic characteristics soil and water conservation structures including check dams, stop dams, percolation tanks and farm ponds were identified.

Biswajit *et al.* (2019) evaluated multisite performance using SWAT model in the Gomti River basin in India using 5 years of hydrometeorological datasets (2009-2013). The results found that AMC II was initial curve number. The coefficient of determination and Nash-Sutcliffe efficiency were observed as 0.85, 0.84 and 0.87, 0.86 respectively. The percent bias values during calibration and validation period were found as -13.3, -14.7 and -4.0, -15.7 respectively.

Pramod *et al.* (2019) determined land use/land cover analysis in Bramhamgarimatam village in Kadapa district of Andhra Pradesh in India using Remote Sensing and GIS. SOI topographic sheets of 1:50,000 scale and IRS P6 satellite image was used for the study. The land use/land cover analysis was attempted based on thematic mapping which classified into built-up land, agriculture land, water bodies, forest and waste land. The results showed that in the study area major natural resource is forest. The land under built-up and land used for cultivating is decreasing. The forest land covers area of 106 km² (38%), uncultivated land covers 122 km², cultivated land covers 24 km² (24%), water bodies occupied 66 km² (21%) and built-up

occupied 3000 m² (1%). The study also showed the well-developed dendritic drainage pattern in the study area.

Radha and Manjeet (2019) studied suitable sites for water harvesting structures in Gadela watershed using remote sensing and GIS. Satellite image of 30 m resolution was used to make elevation and slope map. Other thematic maps like land use land cover, geomorphology, soil, transmissibility and runoff maps were prepared. Using weighted overlay tool weights were assigned and final suitability map was generated. The resulted priority map found that 31% of area is highly suitable, 45% is medium suitable and 24% is less suitable. Twenty-four check dams, twenty-five farm ponds, four nala bunds, contour trench and a gully plug were proposed for the study area by using IMSD guidelines.

Prabuddh *et al.* (2020) studied changes in LULC patterns of rani Khola watershed of Sikkim Himalaya for the periods 1988-1996, 1996-2008 and 2008-2017. Landsat-5 TM and Sentinel 2A (Multispectral Instrument) MSI images were used to extract land cover maps. Supervised classification using Maximum Likelihood Classifier (MLC) was applied for LULC maps. The accuracy of the classified maps was assessed by field observations and site-specific interviews. Six major classes i.e., agriculture, barren land, built-up area, dense forest, open forests and waterbodies were identified and forest cover was the major land use class. The results showed that dense forest, built-up area and water bodies increased by 16.40% (41.76 km²), 2.13% (5.41 km²) and 0.11% (0.28 km²) while open forest, agriculture and barren land have decreased by -13.98% (-35.59 km²), -2.83% (-7.22 km²) and -1.82% (0.464 km²) respectively.

3. Estimation of water budget

Kevin *et al.*, (2006) estimated global water budget and its annual cycle using observational and model data. The precipitation (P), evapotranspiration (E), atmospheric moisture convergence over land and change in atmospheric storage are presented in three datasets. Community land Model run with realistic atmospheric forcings was used to estimate evapotranspiration. The results showed that E-P were contrasted from atmospheric moisture budgets based on 40-yr analysis.

Alka *et al.*, (2016) determined hydrological budget based on horizontal and vertical water fluxes acting in inward and outward directions. The study evaluated the mass changes in prominent reservoir regions through three independent approaches i.e., fluxes, storages and gravity. Remote sensing technology, in-situ data and hydrological model outputs using WaterGAP Global Hydrological Model (WGHM) and Global Land Data Assimilation System (GLDAS) was used in the study. The results showed that by Gravity Recovery and Climate Experiment (GRACE) signal can be better explored by a hybrid method than by model-based storage estimates. GLDAS based storage estimations perform better than WGHM for the study area.

Pendke *et al.*, (2018) conducted water budget under deficit years at Babhulgaon watershed in Parbhani district of Maharashtra. The study found that during 2014, the total rainfall received was 398.1 mm which was 52% less than average normal rainfall while in 2015, an amount of 407.8 mm of rainfall was received which was 51% less to average normal monsoon rainfall. Comparing 2014 and 2015, the major losses occurred as soil evaporation (59.71 mm) and transpiration (155.26 mm) respectively and soil evaporation (61.94 mm) and transpiration (161.61 mm) respectively in 2015. The total crop water requirement of the year 2014 was 409.55 ha-mm and for 2015 was 418.55 ha-mm. The study showed that there is still necessary for constructing nala bunds, farm ponds, earthen dams, etc. in the study area.

Chang and Chung (2021) analyzed water budget considering surface water and ground water interactions in South Korea. The collected data was for six wells and two river-level observation points on the study site. The study showed that the structures have significant impacts on inflow and outflow from the river to the ground water reservoir. They used time-variable recharge data using SWAT model for watershed hydrology to determine the amount of ground water recharge that was input to ground water model. The result indicated that 2.5 cm ground water was declined on average every year at the study area. The study suggested that proper artificial recharge method of injecting water by wells in the study area.

III. MATERIALS AND METHODS

The present research pertaining to “Planning and Designing of Soil and Water Conservation Structures for Dapoli Tehsil using Remote Sensing and GIS” was carried out at Department of Soil and Water Conservation Engineering, College of Agricultural Engineering and Technology, DBSKKV, Dapoli in the year 2020-2021. This chapter consists of the description of the study area, its characteristic features, methodology adopted to generate different thematic maps, standards for selecting suitable conservation structures and other relevant components of the study.

2.8 Study Area

Location

Dapoli tehsil is a tehsil situated in Ratnagiri district of Maharashtra. There are 183 villages in the tehsil. The surrounding area is bordered by the Sahyadri hill range on North, East, South and Arabian Sea on the West. The area lies in between 17°34' to 17°56' N latitude and 73°03' to 73°20' E longitude with altitude ranging from 20 m to 250 m above mean sea level (msl). It is situated in South-Western part of Maharashtra on the Arabian sea coast. The total geographical area of the watershed is 910.4 km². The landscape of Dapoli is dominated by forests, plateaus, agricultural lands, fruit orchards and settlement. The location map of study area is shown in Figure 3.1.

Climate

The average annual rainfall is 3500 mm, of which about 90% received during the south-west monsoon of June to September with about 95-100 rainy days in most of the years. The climate in the region is temperate with average minimum and maximum temperature varying from 18.8°C to 34.2°C respectively. The minimum and maximum relative humidity ranges between 53.6% and 91.1% respectively. The average annual evaporation in the region is 1200 mm.

2.9 Data and software used

A specific frame work was developed for delineation of watershed and creating thematic layers using satellite data, derived from remote sensing information with the help of ArcMap software available with Dr. BSKKV, Dapoli.

LOCATION MAP OF STUDY AREA

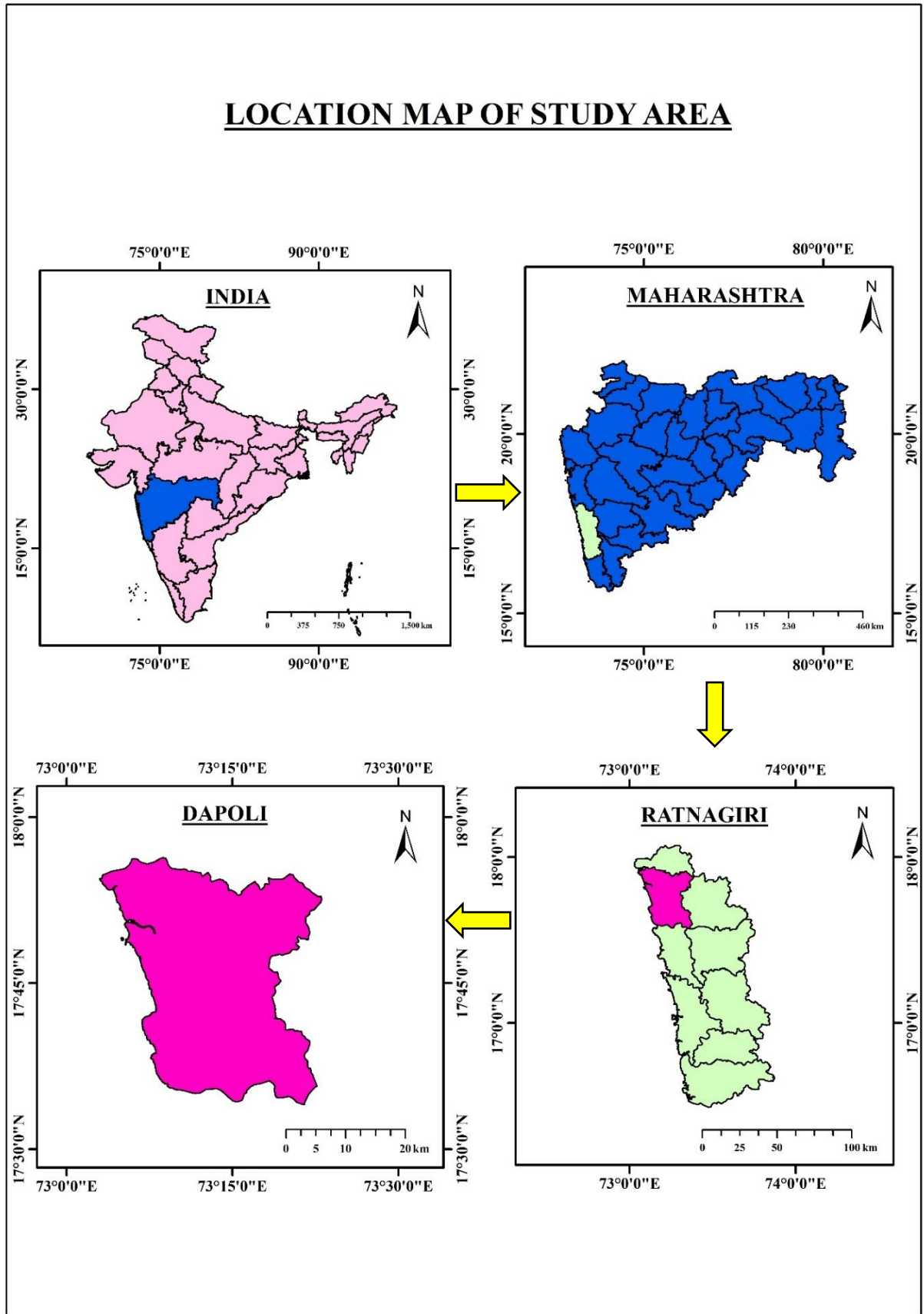

Figure 3.1. Location Map of the Study Area

Data acquisition

The various information required for the study was procured from various sources. An overview of data collected is given below:

- i. Digital Elevation Model (DEM) of Cartosat-1 from Bhuvan.
(Website: https://bhuvan.nrsc.gov.in/bhuvan_links.php)
- ii. Landsat-8 OLI satellite image of 30 m spatial resolution from USGS Earth explorer.
(Website: <https://earthexplorer.usgs.gov/>)
- iii. Daily rainfall data of past 30 years (1991-2020) from www.maharain.gov.in.
- iv. Geology data from Geological Survey of India.
(Website: <https://bhukosh.gsi.gov.in/Bhukosh/Public>)
- v. Geomorphology data from Geological Survey of India.
(Website: <https://bhukosh.gsi.gov.in/Bhukosh/Public>)
- vi. Lineaments data from Geological Survey of India.
(Website: <https://bhukosh.gsi.gov.in/Bhukosh/Public>)
- vii. Soil data from European Soil Data Center (ESDAC).
(Website: <https://esdac.jrc.ec.europa.eu/>)
- viii. Shape file of the study area is downloaded from DIVA GIS.
(Website: <https://www.dis-gis.org>)
- ix. Daily weather data downloaded from Global Weather Data for SWAT
(Website: <https://globalweather.tamu.edu>)

Development of GIS database

The development of GIS data in the desired format is complex in nature particularly for hydrological analysis for the conservation measure. The data required for the analysis is varied. The shape file of the study area is downloaded from DIVA GIS and DEM of the study area is extracted from CartoDEM tile by using Spatial Analyst Tool.

Software used

Arc Map 10.2.2 software available with Dr.BSKKV, Dapoli has been used for this research work. The functions such as digitization of contour, editing of raster and vector maps, DEM generation, analytical hierarchy process, storage and retrieval of characteristic data, mapping, merging, clipping, masking, etc. were performed in the software. The flowchart used in the methodology is shown in Figure 3.2.

3.3. Digital Elevation Model (DEM)

A Digital Elevation Model (DEM) is a digital representation of ground surface topography. In other words, it is the digital representation of the land surface elevation with respect to any reference datum. They are used to determine the terrain attributes such as elevation at any point, slope and aspect. A DEM can be represented as a raster or as a vector-based Triangular Irregular Network (TIN). The TIN DEM data set is also referred as a primary DEM whereas the Raster DEM is referred to as a secondary DEM. They are frequently obtained by remote sensing rather than direct survey. They can also be acquired through techniques such as photogrammetry, LIDAR, IfSAR or InSAR, etc. Terrain features such as drainage basins and channel networks can also be identified from DEM. The DEM are widely used in hydrologic and geologic analysis, hazard monitoring, natural resources exploration, agricultural management, etc. Indian Space Research Organisation (ISRO) provides all DEM data of India through its Bhuvan portal.

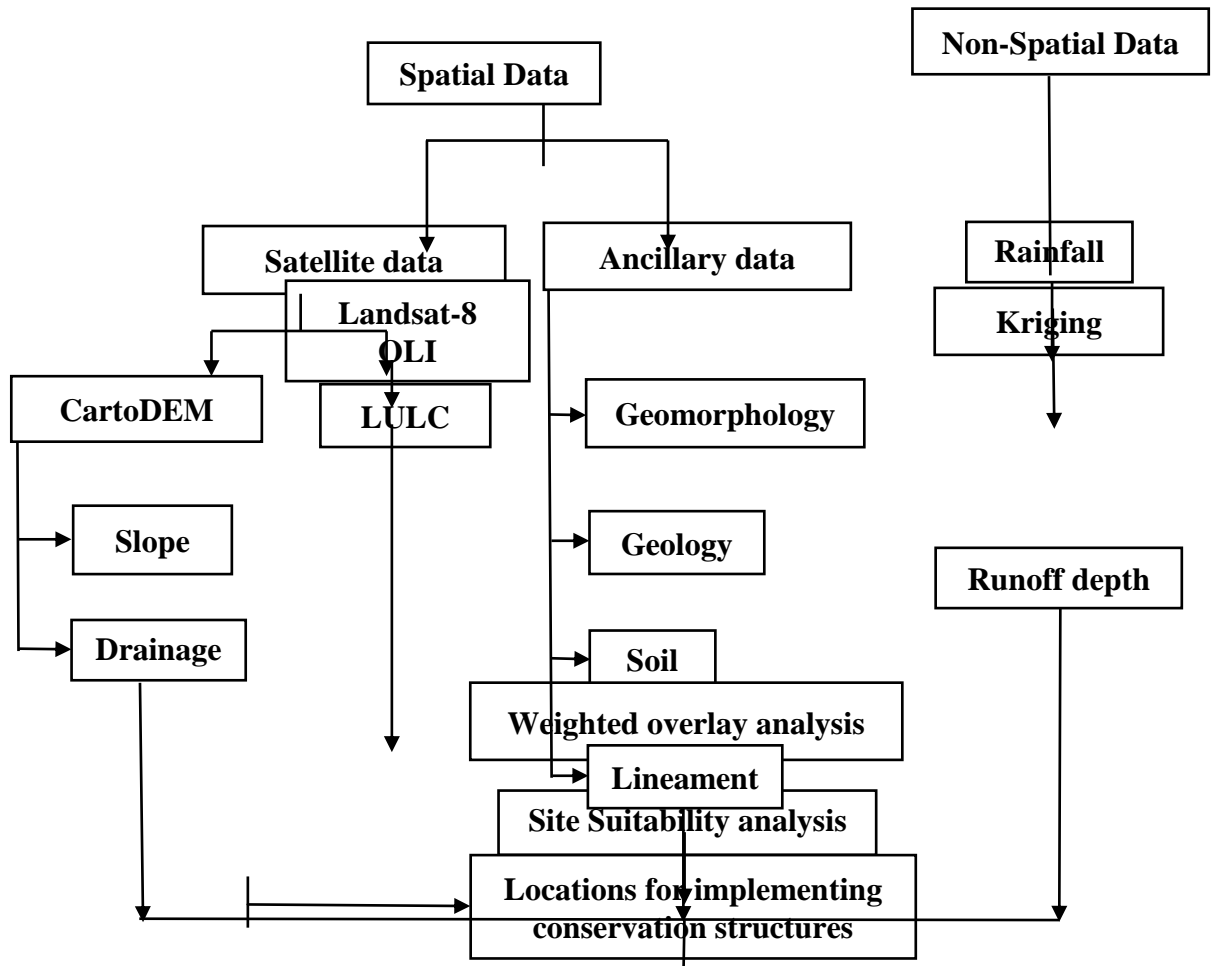

Figure 3.2: Flow chart showing the methodology adopted for identifying suitable sites for soil and water conservation structures

3.4. Procedure for identifying stream orders in the study area

Open ArcGIS and create a new blank map document. Use the Add Data button from the toolbar menu for adding the DEM and shape file of the study area i.e., Dapoli tehsil. The spatial coordinate system of World Geodetic System (WGS 1984) UTM 43N was given and used for all the layers in the entire study.

3.4.1. Fill tool

Criteria for selection of different conservation structures

The fill tool in the hydrology tool box of the Spatial Analyst Tool is used to remove any imperfections in DEM. The input surface raster is set as DEM and the output raster is set as *fill* in the working directory.

3.4.2. Flow direction tool

A flow direction grid assigns a value to each cell of DEM to indicate the direction of flow i.e., the direction that water will flow from that particular cell based on the topography of the landscape. Select *fill* as the input flow direction raster and save the output raster as *flow_direction*.

3.4.3. Flow accumulation tool

The flow accumulation tool calculates the flow into each cell by identifying the upstream cells that flow into each downstream cell. This step is also done based on the landscape topography of the area. Select *flow_direction* as the input raster and save the output flow accumulation as *flow_accumulation*.

3.4.4. Raster calculator tool

Raster calculator builds and executes a single map Algebra expression using Python syntax in a calculator-like interface. Take *flow_accumulation* and assign threshold as ≥ 3000 . Give the output name as *raster_calculator*. Then, all the accumulations which are >3000 and <3000 will assign in separate grid codes.

3.4.5. Stream order tool

Stream order assigns a numeric order to segments of a raster representing branches of a linear network. Set *raster_calculator* as input for stream raster, *flow_direction* as the input for flow direction raster and name the output raster as *stream_order*. Strahler method of stream ordering is opted.

3.4.6. Stream to feature tool

It converts a raster representing a linear network to features (polyline) representing the linear network. The DEM was processed using Hydrology tool. The input is set as *stream_order*, *flow_direction* as input for flow direction raster and output as *Stream_polygon*. The values of different morphological parameters are found in the attribute table of this output file.

3.4.7. Line density tool

Line density calculates a magnitude per unit area from polyline features that fall within a radius around each cell. The input polyline feature is set as *Stream_order*, population field is set as grid code and output as *drainage_density*. The cell size is given as 30 m and units of the area is set as km². The environment (processing extent and raster analysis) is set as *Dapoli* shape file.

3.4.8. Slope tool

DEM from Cartosat 1 is to be used as the basic data for slope map generation. The slope of the area is determined from Spatial Analyst Tool Surface Slope. DEM is set as the input raster and output raster is set as *Slope* and measured in percentage. In the environments, the processing extent and raster analysis are set as DEM file. The generated output map is then reclassified into 5 classes.

3.5. Morphometric analysis

Morphometric analysis of the watershed is the best method to identify the relationship of various aspects in an area. Watershed is a natural hydrological entity from which surface runoff flows to a defined river, drain, channel or stream at a particular point. Watershed analysis based on morphometric parameters is very important for watershed planning since it gives an idea about the basin characteristics regarding soil condition, runoff characteristics, slope, topography, surface water potential, etc. The morphometric analysis of the watershed helps to know the aspects of linear, areal and relief parameters.

3.5.1. Linear aspects of the watershed

Linear aspects include the measurements of linear features of drainage like stream order (U), bifurcation ratio(R), mean stream length (L_{sm}), stream length ratio (R_L), etc. The linear aspects of the drainage basin are discussed below.

Stream order (U)

Stream ordering is the first step of quantitative analysis of the basin. It is a method of assigning a numeric order to links in a stream network. This order is a method for identifying and classifying types of streams based on their number of tributaries. A first order stream is an unbranched tributary and a second order stream is formed by two or more second order streams and so on. The highest order stream is called as Trunk.

Stream number

The total number of streams present in given stream order is called as Stream number.

Stream length (L_u)

The total length of individual stream of each order is the stream length of that order.

Mean stream length (L_{um})

Mean stream length is obtained by dividing the total length of stream of an order (L_u) by total number of segments in the order (N_u). It is a dimensionless property revealing the characteristic size of components of a drainage network and its contributing watershed surface (Strahler, 1964). The L_{um} values varies from basin to basin as it depends on the size and topography of the basin. Strahler (1964) indicated that the L_{um} is related to the size and associated surfaces. It is noted that the L_{um} value of any stream order is greater than that of the lower order and less than that of its next higher order in the basin.

$$L_{um} = \frac{L_u}{N_u} \dots\dots\dots (3.1)$$

Stream length ratio (R_L)

Stream length ratio is defined as the ratio of total length of stream of any order (L_u) to the average length of stream of the next lower order (L_{u-1}).

$$RL = \frac{L_u}{L_{u-1}} \dots\dots\dots (3.2)$$

Bifurcation ratio (R_b)

The ratio of number of segments of a given order N_u to the number of segments of the next higher order N_{u+1} is termed as Bifurcation Ratio (R_b). It is a dimensionless property and generally ranges from 3 to 5. The lower values of R_b characterize less structural disturbances (Strahler, 1964) and higher values of R_b indicates strong structural control on the drainage pattern. A circular basin is likely to have low R_b whereas an elongated basin is likely to have high R_b .

$$Rb = \frac{N_u}{N_{u+1}} \dots\dots\dots (3.3)$$

3.5.2. Areal aspects of the watershed

Areal aspects of geomorphological study of watershed includes form factor, elongation ratio, circulatory ratio, drainage density and stream frequency.

Form factor (F_f)

Form factor is a dimensionless ratio of watershed area (A) to the square of the length of the watershed (L_b). The value of form factor varies from 0 (highly elongated shape) to 1 (perfect circular shape). Smaller the value of form factor, more elongated will be the watershed and flows for longer duration. Higher the value of form factor, circular is the watershed and flows for shorter duration.

$$F_f = A / L_b^2 \dots\dots\dots (3.4)$$

where, A = Area of the watershed

L_b = Length of basin

Elongation ratio (R_e)

The ratio of diameter of a circle of the same area as the basin (A_w) to the maximum basin length (L). It is a dimensionless quantity. It is a measure of shape of the basin and depends on climatic and geologic conditions. Generally, the elongation ratio value is categorized into two classes, i.e., the lower value which means elongated watershed and higher value which means circular watershed. R_e is also categorized into 4 classes as elongated (<0.7), less elongated (between 0.7 to 0.8), oval (between 0.8 to 0.9) and circular (> 0.9). Higher elongation ratio values have high infiltration capacity and low runoff, whereas elongation ratio having low value have circular basin is more efficient in the discharge of runoff than an elongated basin.

$$R_e = \frac{2}{L} \times \sqrt{\frac{A_w}{\pi}} \dots\dots\dots (3.5)$$

Circulatory ratio (R_c)

Circulatory ratio is the ratio between the area of watershed to the area of the circle having the same circumference as the perimeter of the watershed. It is a dimensionless property. R_c is more influenced by length, stream frequency, land cover, climate, relief, geological structures and slope of the basin. It ranges from 0 (for a line) to 1 (for a circle). Low value indicates youth stage, medium value indicates mature stage and high value indicates older stages of the tributaries in the basin.

$$R_c = \frac{4 \times A \times 3.14}{P \times P} \dots\dots\dots (3.6)$$

where, A_c = area of circle having equal perimeter as the perimeter of watershed

P= perimeter of the watershed (km)

Drainage density (D_d)

Drainage density is defined as the ratio of total length of all streams (L) of all orders within a watershed to the total area of the watershed (A). Low drainage density indicates the ground water potential of an area due to its relation with surface runoff and permeability. Low drainage density generally results in areas of permeable sub soil material, dense vegetation and low relief (Nag 1998) where as high drainage density is the resultant of impermeable subsurface material, sparse vegetation and mountainous relief. Low D_d leads to coarse drainage texture while high D_d leads to fine drainage texture.

$$Dd = \frac{\sum_{i=1}^K L}{A} \dots\dots\dots (3.7)$$

where, D_d = Drainage density

K = Principal order stream

A = Area of the watershed

Stream frequency (F_s)

Stream frequency is the total number of channel segments of all stream orders (N_u) per unit area (A_w) (km⁻²). High F_s points to a large surface runoff, steeper ground surface, impermeable subsurface, sparse vegetation and high relief conditions while low stream frequency indicates high permeable geology and low relief.

$$F_s = \frac{Nu}{Aw} \dots\dots\dots (3.8)$$

3.5.3. Relief aspects of the watershed

Relief aspects of the watershed includes basin relief, relief ratio, relative relief and ruggedness number.

Basin relief (R)

Basin relief is the difference between highest (H) and lowest (h) points in a watershed. The low relief value indicates high gravity of water flow, high infiltration rate and low runoff conditions while high relief value indicates low gravity of water flow as well as infiltration into the ground and high runoff conditions.

$$R = H - h \dots\dots\dots (3.9)$$

Where, H = maximum elevation (m)

h = minimum elevation (m)

Relief ratio (R_h)

Relief ratio is defined as the ratio between the total relief of a basin (H) and the longest dimension of the basin parallel to the main drainage (L). It is a unitless

parameter. It measures overall steepness of the watershed and is also considered as an indicator for the intensity of erosion which occurs in the watershed. Higher values of relief ratio indicate steep slope and high relief while the lower values indicate the presence of basement rocks that are exposed in the form of small ridges and mounds with lower degree of slope.

$$R_h = \frac{H}{L} \dots\dots\dots (3.10)$$

where R_h = relief ratio

H = total catchment relief (km)

L = maximum length of the catchment (km)

Ruggedness number (R_n)

Strahler (1964) defined Ruggedness number is the product of watershed relief (H) and drainage density (D_d). It usually combines its slope steepness with its length. Extremely high values of R_n occur when slopes of the basin are not only steeper but long as well. Low values of R_n indicate low erosion intensity in the basin.

$$R_n = H \times D_d \dots\dots\dots (3.11)$$

where R_n = ruggedness number

H = watershed relief (km)

D_d = Drainage density (km/km²)

3.6. Land Use-Land Cover (LULC)

Land use/Land cover maps play a significant role in planning, management and monitoring programs from local level to national level. This type of information provides a better understanding of land utilization aspects and it plays an important role in the formation of policies and programs required for development and planning. LULC maps of an area provide information to understand the current landscape.

In the present study, LULC of the area of interest is classified based on supervised classification in ArcGIS. The Landsat-8 OLI satellite image is downloaded from USGS Earth Explorer for the study. Landsat-8 carries Operational Land Imager (OLI) and Thermal Infrared Sensor (TIRS) science instruments. These two sensors provide seasonal coverage of the global land at a spatial resolution of 30 m (Visible, NIR, SWIR), 100 m (thermal) and 15 m (panchromatic). It has 11 bands of which band 1,2,3,4,5,6,7,8,9 are scanned by OLI and band 10,11 by TIRS sensors. The Table 3.1 shows the interpretation of Landsat-8 OLI satellite image.

Table 3.1: Landsat-8 OLI Interpretation keys

S. No	LULC	Tone	Size	Shape	Texture	Association
1	Agricultural land	Dark red	Varying	Irregular	Fine to medium	Agricultural land
2	Forest	Bright red	Varying	Irregular	Coarse with mottling	Outskirts of agricultural land
3	Settlement	White	Varying	Definite	Coarse	Streets
4	Barren land	Creamy white	Varying	Irregular	Coarse with mottling	Agricultural land
5	Water body	Dark blue	Varying	Irregular/ Definite	Smooth	Agricultural land/ Built-up area/ Forest

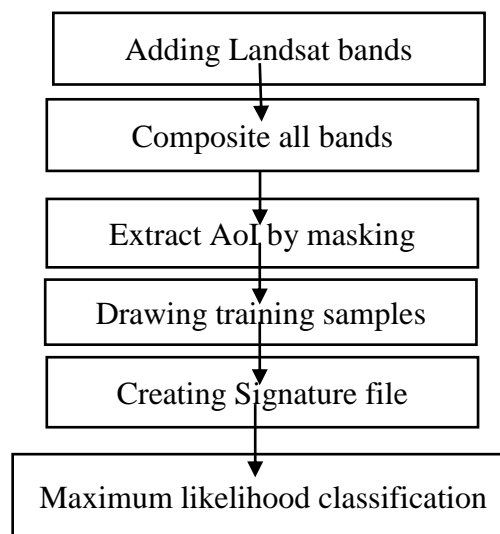

Figure 3.3: Flowchart showing the process of Maximum likelihood classification in ArcMap

The first 7 bands of Landsat 8 were added in ArcMap using the add data tool. Then navigate to Geoprocessing > Arc Toolbox > Data Management Tools > Raster > Raster Processing > Composite Bands. All the seven bands were selected in sequence as input raster. The name and the output location were specified and OK. Then the Multi-band raster from Landsat 8 is created. Figure 3.3 shows the process of Maximum likelihood classification in ArcMap.

Then the study area raster was extracted by using Extract by mask tool. In ArcMap navigate to Geoprocessing > Spatial Analyst Tool > Extraction > Extract by Mask. The input raster was set as the composite band layer, input raster or feature mask

data was set as the study area shape file and output raster name and location were specified.

The next step is adding training samples. In ArcMap, select Image classification by right clicking on the blank space on toolbar. The image classification toolbox provides a user-friendly environment for creating training samples and signature files for supervised classification. The tools and buttons available on the toolbar are Training sample manager, Clear Training samples, Training Sample Drawing Tools and Select Training Sample. The image layer was chosen in the layer list and draw polygon was selected. In the map display, the area that belong to the known class was identified. Five classes named built-up area, water body, agriculture, forest and barren land were created. Next a signature file was created and all these training samples were saved in it. Then Maximum likelihood classification was selected and input raster bands was set as extracted area of interest, input signature file was set as signature file, output name and location were given. Then the final LULC raster is generated.

The area and percentage of area covered is calculated by converting from raster to vector from the Conversion tools.

3.7. Geology

The data was collected from Bhukosh which is a gateway to all geoscientific data of Geological Survey of India (GSI). The shapefiles of study area and geology data were added in ArcMap. The area of interest was clipped using clip tool from Geoprocessing in menu bar. Both the layers must be georeferenced first. Then, the input feature was set as geology, clip feature as shape file of the study area and in output feature class name and location was given. The geology map was then generated. This was then converted to raster using polygon to raster tool with 30 m resolution.

3.8. Geomorphology

The geomorphology data was collected from Bhukosh website which is a gateway to all geoscientific data of GSI. The shape files of the area of interest and geomorphology data were added in ArcMap using Add data tool. The study area was clipped using Clip tool from Geoprocessing in menu bar. The input feature was set as geomorphology shape file, clip feature as study area and in output feature class name and location was given. The geomorphology map was then generated. This layer was converted to raster using polygon to raster tool with 30 m resolution.

3.9. Lineaments

The lineament data was collected from Bhukosh website which is a gateway to all geoscientific data of GSI. The shape files of the area of interest and lineament data were added in ArcMap. The study area lineaments were clipped using Clip tool from Geoprocessing tool bar. The input feature was set as lineament shape file, clip feature as study area and in output feature class name and location was given. Then lineament map was generated. Then using the line density tool, the lineament layer is converted to lineament density in raster format.

3.10. Soil

The soil map was collected from ESDAC website and added in ArcMap. It was first georeferenced using tehsil boundary shape file as datum. The soil map of study area is digitized, rasterized and clipped using shapefile in ArcMap 10.2. Then with respect to soil groups, the hydrological and textural classes were generated. The class details of each number were found out from the legend and edited in the attribute table. This polygon is converted to raster having 30 m resolution.

3.11. Rainfall

The annual rainfall data from 1991-2020 (30 years) of Ratnagiri district was collected from maharains.gov website and average annual rainfall values are tabulated as shown in Appendix-II. These values had been imported to ArcMap as .csv (comma separated value) file. The shape file of boundary of Ratnagiri district and the point data which contains rainfall values were added using Add data button in ArcMap. In the tool bar of ArcMap, go to Geoprocessing > Environments and set the processing extent and raster analysis as the shape file layer. Then in the Arc toolbox > Spatial Analyst Tool > Interpolation > Kriging. In the Kriging dialog box, the input was given as point data which contains rainfall values. The z value field was chosen as average rainfall and output location was specified in the output surface raster and OK. Then the generated layer was reclassified using Symbology option into 4 classes. At last, the study area map has been extracted by using the extract by mask tool.

3.12. Runoff depth

Arc SWAT is an ArcGIS-ArcView extension and GUI for SWAT (Soil and Water Assessment Tool). SWAT model is developed by United States Department of Agriculture-Agriculture Research Services (USDA-ARS). It is used for watershed modellings like impact of land management practices on water, sediment and agricultural chemical yields in large, complex watersheds with varying soils, land use

and management conditions over long periods of time, etc. It is also used for estimating available water resource, managing check dams, quantifying the impacts from land use changes on runoff, modelling the long-term impact of management practices. In the present study, SWAT model was used to generate runoff depth in the study area.

The hydrometeorological data is needed to run the model. The major hydrometeorological data includes DEM, soil map, land use/land cover map, slope map and meteorological data which contains rainfall (mm), maximum and minimum temperature (°C), wind speed (m/sec), relative humidity (%) and solar radiation. The procedure followed for modeling using SWAT is shown in Figure 3.4.

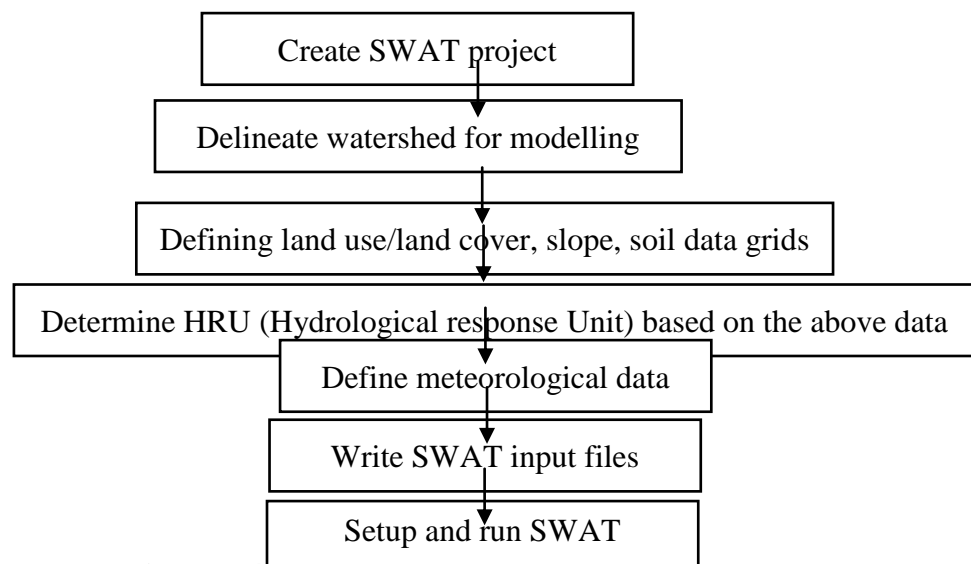

Figure 3.4. Procedure to run SWAT model

3.13. Site suitability analysis

Site suitability analysis is a type of analysis used in GIS to determine the best place to locate something (Patel *et al.*, 2012). Weighted overlay site selection analysis allows users to rank raster cells and assign a value to each layer. For performing site selection analysis various criteria from GIS software will rate the best ideal sites. Site selection analysis can be performed with vector or raster data but weighted overlay site selection is most widely used using raster data. Weighted site selection is an important site selection method because it includes options for viewing next-best sites.

3.13.1. Weighted overlay analysis

There is standard workflow that should be followed in order to use weighted site selection. The workflow usually begins with defining a problem or criteria such as

locating some potential sites. The next step is to gather all data and create raster surfaces which are to be used in the analysis. The third step is by reclassifying the layers, weighting them and then overlaying the output layers with background information to see the best potential sites. Reclassification is important because it is used to simplify the interpretation of raster data by changing a single input value into a new output value (ESRI). By using reclassification, they are all based on the same ranking scheme that can be used to compare and rank the least and most suitable sites. Weighing layers is also critical step in weighted site selection because it allows to place varying levels of importance on different parameters. Weights are assigned as different percentages that will add up to 100%. The suitable values in between 1 and 8 for all eight parameters are to be given by taking their hydrogeological importance into account based on literatures reviewed. The highly influencing parameter will be assigned the value of 8 and the least influencing parameter will be assigned the value of 1. The intermediate values are to be given accordingly. Then the suitable area in the watershed map will be generated.

3.13.2. Potential sites for soil and water conservation structures

The multi-layer integration of land use/land cover, slope, drainage density, runoff will give the suitability areas for identifying soil and water conservation structures like check dams, percolation tanks or nala bunds and farm pond with lining. By creating separate point shape files in ArcMap for each structure, the locations were selected based on the technical guidelines which were shown in Table 3.2.

Table 3.2: Decision rules for selection of suitable locations for soil and water conservation structures

Type of structure	Slope	Runoff	Stream order	LULC
Check dams	<10%	High to low	3 rd , 4 th	River/Stream
Percolation tanks	0-3%	High to low	2 nd and 3 rd	Barren land or scrub land
Farm Pond with plastic lining	1-3%	Moderate	3 rd , 4 th and 5 th	Agricultural land, barren land

3.13.3. Check dam

Check dams are very popular type of water harvesting structures. They are small dams and usually constructed of rock, sediment retention fibre rolls, pea gravel bags or sand bags across a natural or manmade channel or drainage ditch. They are

constructed to reduce the runoff velocity and reduces erosion. Check dam prevents the wastage of rain water discharging into the sea or ocean and provides fresh water bodies for local usage. The following formulas were used to design check dam.

Design of check dam:

Simple Kresnik formula,

$$Q = 25 A^{1/2} \dots\dots\dots (3.12)$$

Where, Q = maximum discharge of the stream (m³/sec)

A= area of catchment (km²)

Discharge capacity is given by the following formulae,

$$Q = 1.75 LH^{3/2} \dots\dots\dots (3.13)$$

where Q= runoff (m³/sec)

L = length of crest (m)

H = depth of flow (m)

Freeboard, f = 0.3 m

Height of wing wall above crest, d = H + f

$$\begin{aligned} \text{Length of apron} &= 0.75 \times (\text{Fall} + \text{Height of wing wall above crest}) + \text{fall} \\ &= 0.75 \times (h + d) + h \end{aligned}$$

3.13.4. Percolation tank

Percolation tank is a small, traditional and popular water storage structure which serves the purpose of recharging ground water. These are generally constructed across streams or nalla in order to impound a part of run-off water (IMSD, 1995). Percolation tanks are water bodies submerging a highly permeable land area so that the surface runoff will percolate and recharge the ground water storage. These are usually constructed on second and third order streams. The following procedure is used to design the percolation tank.

Design of percolation tank:

Volume of runoff,

$$R = \frac{CPA}{1000} \dots\dots\dots (3.14)$$

where, C = curve number

P = precipitation (mm)

A = catchment area (ha)

R = runoff

Volume of tank,

$$V = \frac{d}{6} \times (A_0 + 4A_1 + A_2) \dots\dots\dots (3.15)$$

where, A_0 = bottom surface area

A_1 = mid-section area

A_2 = top surface area

d = depth of tank

The detailed calculation for design of percolation tank is shown in Appendix – VI.

3.13.5. Farm pond with plastic lining

Farm ponds are reservoir like water harvesting structures that are constructed for the purpose of storing rain water and surface runoff in a catchment. They solve the purpose of farm needs like supply of water for irrigation of crops, cattle feed, fish production, etc. They also play a key role in flood control by constructing them in large numbers in a catchment and they also have a significant role in rainfed farming. They are also used for irrigating rabi and summer crop using micro irrigation. The following procedure is followed for design of farm pond.

Table 3.3: Recommended side slope

S. No.	Soil type	Slope (horizontal: vertical)
1	Clay	1:1 to 2:1
2	Clay loam	1.5:1 to 2:1
3	Sandy loam	2:1 to 2.5:1
4	Sandy	3:1

(Source: Critchley *et al.* 1991)

Design of farm pond:

In the present study farm pond has been proposed for irrigating area of 10 ha.

Assume, 5 ha area – Fruit crop

5 ha area – Vegetable crop

So, water requirement for 5 ha vegetable crop is about 2000 m³ and

Water requirement for 5 ha fruit crop is about 1000 m³.

Total amount of water requirement is 3000 m³.

Assume, depth of farm pond = 3 m

$$\text{Volume of farm pond (V)} = \frac{A+4B+C}{6} \times D \quad \dots\dots\dots (16)$$

where, A = top surface area (m²)

B = mid-section area (m²)

C = bottom surface area (m²)

D = average depth of pond (m)

The detailed calculation for design of farm pond is shown in Appendix - VII

3.14. Estimation of Water Budget

Water budget

A water budget is a hydrological tool used to quantify the flow of inflow and outflow water of a system. It is an accounting of all the water that flows into and out of an area. The concept behind a water budget is that the rate of change of water stored in a specific area is balanced by the quantity and rate at which water flows into and out of that specific area. A water budget is calculated for a specified period of time and calculated for a range of conditions.

The water budget is expressed as an equation as follows:

$$P = E_T + E_{\text{pan}} + R_s + G_s + \Delta S \quad \dots\dots\dots (17)$$

where, P= precipitation

E_T = evapotranspiration by Hargreaves equation

E_{pan} = pan evaporation

R_s = surface runoff

G_s = ground water recharge/ sub-surface recharge

ΔS = change in soil moisture storage

The first three terms of the water budget equation, precipitation, evaporation and evapotranspiration are natural processes that are not affected by development. But changes in land use can notably affect surface runoff and sub-surface flow.

Components

Precipitation (P)

Precipitation is the primary water input to the hydrologic cycle and is evaluated for all water budget calculations. It is defined as the falling of water from the atmosphere in form of rain, snow, mist, etc on the earth. It is measured in the form of depth on land surface. The precipitation data was collected from Agrometeorological Department, DBSKKV, Dapoli. The daily weather data of the year 2020 was procured and average annual rainfall was found.

Evapo-transpiration (E_T)

Evapo-transpiration is the process by which water is transmitted from the earth surface to the atmosphere by evaporation and by transpiration from plants through stomata in the plant leaves.

In the present study, Hargreaves equation was used to estimate the evapo-transpiration. The equation is as follows:

$$E_T = 0.0023 \times R_a \times (T_{\max} - T_{\min})^{0.5} \times (T_{\text{mean}} + 17.8)$$

..... (18)

Where, E_T = Evapo-transpiration, mm/day

R_a = extra-terrestrial radiation, mm/day

T_{\max} = maximum air temperature, °C

T_{\min} = minimum air temperature, °C

T_{mean} = mean air temperature, °C

The temperature values are taken from the agro-climatic data which is procured from Agrometeorological Department, DBSKKV, Dapoli. T_{\max} , T_{\min} , T_{mean} values are selected from the month of July as this month recorded the highest rainfall in the year 2020. The value of R_a was calculated from the values of mean-monthly extra-terrestrial radiation table from A.M.Micheal text book.

Pan-evaporation (E_{pan})

Pan evaporation is commonly measured by pan evaporimeter. The E_{pan} value was collected from the Agrometeorological Department, DBSKKV, Dapoli. The average E_{pan} value was calculated from the E_{pan} data of July month as it recorded the highest rainfall in the year 2020.

Surface runoff (R_s)

It is the part of rainfall which enters the streamlets immediately after the occurrence of rainfall. When all losses such as interception, depression storage, infiltration, etc are satisfied and if still rainfall continues with the rate greater than infiltration rate, then excess waters flow on the ground surface which tends to move due to slopy lands, is known as overland flow. After sometime, the overland flow joins the streams, nalas, channels, etc which is called as surface runoff.

The surface runoff value was taken from the runoff thematic map which was generated by using ArcSWAT tool in ArcGIS.

Ground water recharge (G_s)

For calculating ground water recharge, Krishna Rao formula (1970) is used.

The equation is as follows:

$$R = K \times (P - X)$$

$$R = 0.35 \times (P - 600)$$

Where, R = ground water recharge due to annual precipitation, mm/yr

P = Annual precipitation, mm/yr

This formula is used for areas with annual rainfall above 2000 mm.

Soil moisture storage (ΔS)

Soil moisture storage is the total amount of water that is stored in the soil within the root zone area of plant.

III. MATERIALS AND METHODS

The present research pertaining to “Planning and Designing of Soil and Water Conservation Structures for Dapoli Tehsil using Remote Sensing and GIS” was carried out at Department of Soil and Water Conservation Engineering, College of Agricultural Engineering and Technology, DBSKKV, Dapoli in the year 2020-2021. This chapter consists of the description of the study area, its characteristic features, methodology adopted to generate different thematic maps, standards for selecting suitable conservation structures and other relevant components of the study.

2.10 Study Area

Location

Dapoli tehsil is a tehsil situated in Ratnagiri district of Maharashtra. There are 183 villages in the tehsil. The surrounding area is bordered by the Sahyadri hill range on North, East, South and Arabian Sea on the West. The area lies in between 17°34' to 17°56' N latitude and 73°03' to 73°20' E longitude with altitude ranging from 20 m to 250 m above mean sea level (msl). It is situated in South-Western part of Maharashtra on the Arabian sea coast. The total geographical area of the watershed is 910.4 km². The landscape of Dapoli is dominated by forests, plateaus, agricultural lands, fruit orchards and settlement. The location map of study area is shown in Figure 3.1.

Climate

The average annual rainfall is 3500 mm, of which about 90% received during the south-west monsoon of June to September with about 95-100 rainy days in most of the years. The climate in the region is temperate with average minimum and maximum temperature varying from 18.8°C to 34.2°C respectively. The minimum and maximum relative humidity ranges between 53.6% and 91.1% respectively. The average annual evaporation in the region is 1200 mm.

2.11 Data and software used

A specific frame work was developed for delineation of watershed and creating thematic layers using satellite data, derived from remote sensing information with the help of ArcMap software available with Dr. BSKKV, Dapoli.

LOCATION MAP OF STUDY AREA

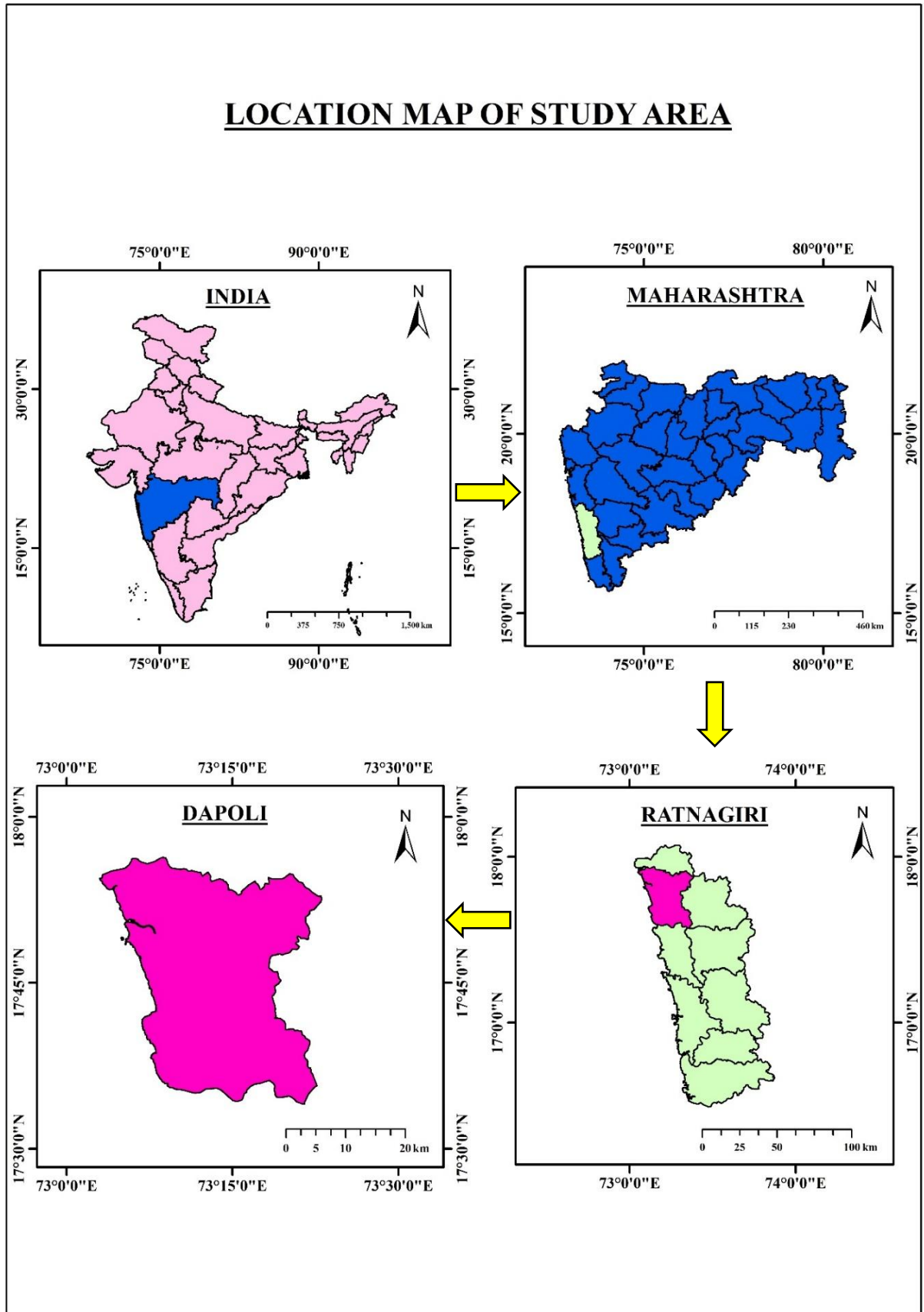

Figure 3.1. Location Map of the Study Area

Data acquisition

The various information required for the study was procured from various sources. An overview of data collected is given below:

- x. Digital Elevation Model (DEM) of Cartosat-1 from Bhuvan.
(Website: https://bhuvan.nrsc.gov.in/bhuvan_links.php)
- xi. Landsat-8 OLI satellite image of 30 m spatial resolution from USGS Earth explorer.
(Website: <https://earthexplorer.usgs.gov/>)
- xii. Daily rainfall data of past 30 years (1991-2020) from www.maharain.gov.in.
- xiii. Geology data from Geological Survey of India.
(Website: <https://bhukosh.gsi.gov.in/Bhukosh/Public>)
- xiv. Geomorphology data from Geological Survey of India.
(Website: <https://bhukosh.gsi.gov.in/Bhukosh/Public>)
- xv. Lineaments data from Geological Survey of India.
(Website: <https://bhukosh.gsi.gov.in/Bhukosh/Public>)
- xvi. Soil data from European Soil Data Center (ESDAC).
(Website: <https://esdac.jrc.ec.europa.eu/>)
- xvii. Shape file of the study area is downloaded from DIVA GIS.
(Website: <https://www.dis-gis.org>)
- xviii. Daily weather data downloaded from Global Weather Data for SWAT
(Website: <https://globalweather.tamu.edu>)

Development of GIS database

The development of GIS data in the desired format is complex in nature particularly for hydrological analysis for the conservation measure. The data required for the analysis is varied. The shape file of the study area is downloaded from DIVA GIS and DEM of the study area is extracted from CartoDEM tile by using Spatial Analyst Tool.

Software used

Arc Map 10.2.2 software available with Dr.BSKKV, Dapoli has been used for this research work. The functions such as digitization of contour, editing of raster and vector maps, DEM generation, analytical hierarchy process, storage and retrieval of characteristic data, mapping, merging, clipping, masking, etc. were performed in the software. The flowchart used in the methodology is shown in Figure 3.2.

3.6. Digital Elevation Model (DEM)

A Digital Elevation Model (DEM) is a digital representation of ground surface topography. In other words, it is the digital representation of the land surface elevation with respect to any reference datum. They are used to determine the terrain attributes such as elevation at any point, slope and aspect. A DEM can be represented as a raster or as a vector-based Triangular Irregular Network (TIN). The TIN DEM data set is also referred as a primary DEM whereas the Raster DEM is referred to as a secondary DEM. They are frequently obtained by remote sensing rather than direct survey. They can also be acquired through techniques such as photogrammetry, LIDAR, IfSAR or InSAR, etc. Terrain features such as drainage basins and channel networks can also be identified from DEM. The DEM are widely used in hydrologic and geologic analysis, hazard monitoring, natural resources exploration, agricultural management, etc. Indian Space Research Organisation (ISRO) provides all DEM data of India through its Bhuvan portal.

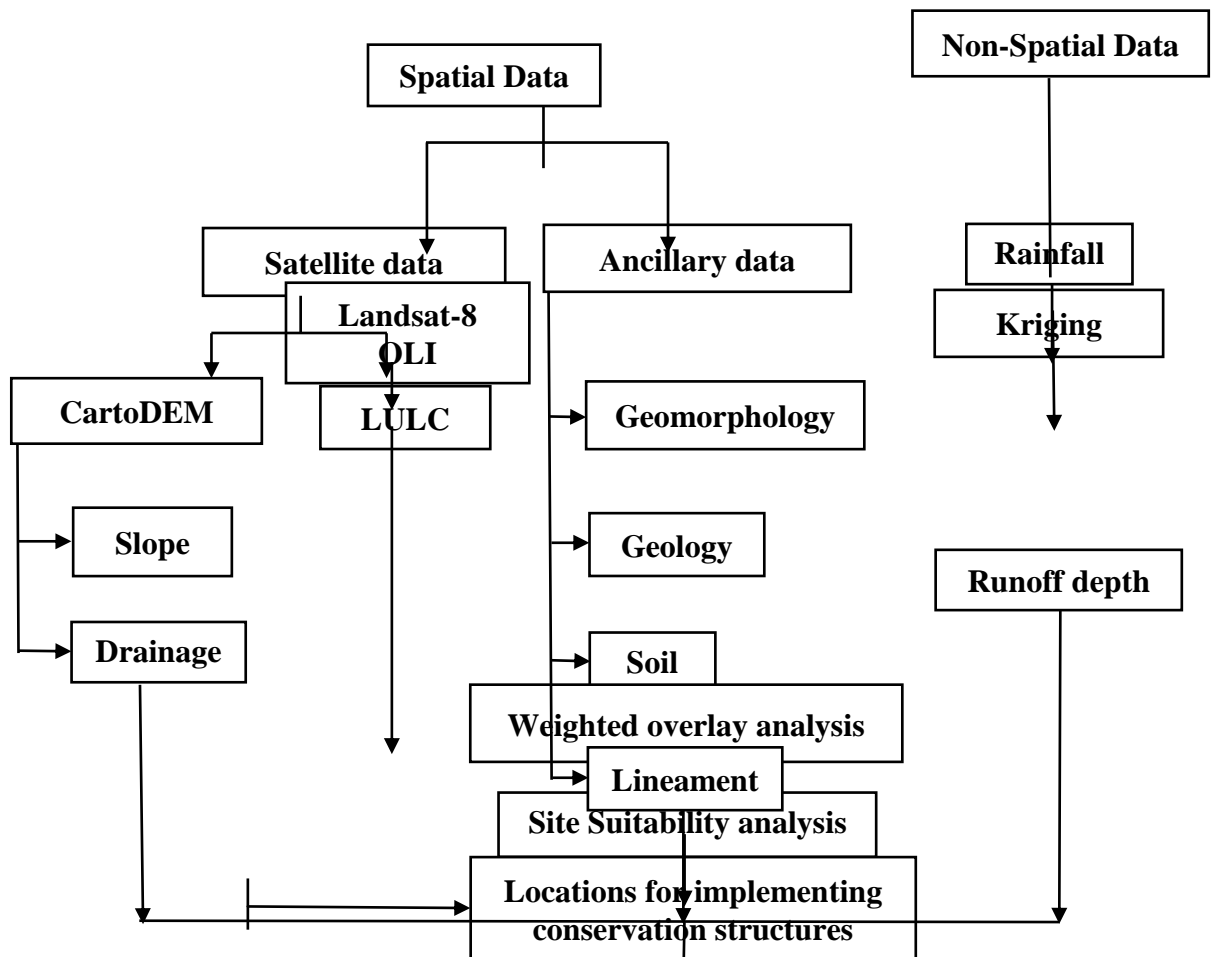

Figure 3.2: Flow chart showing the methodology adopted for identifying suitable sites for soil and water conservation structures

3.7. Procedure

Criteria for selection of different conservation structures

stream orders in the study area

Open ArcGIS and create a new blank map document. Use the Add Data button from the toolbar menu for adding the DEM and shape file of the study area i.e., Dapoli tehsil. The spatial coordinate system of World Geodetic System (WGS 1984) UTM 43N was given and used for all the layers in the entire study.

3.4.1. Fill tool

The fill tool in the hydrology tool box of the Spatial Analyst Tool is used to remove any imperfections in DEM. The input surface raster is set as DEM and the output raster is set as *fill* in the working directory.

3.4.2. Flow direction tool

A flow direction grid assigns a value to each cell of DEM to indicate the direction of flow i.e., the direction that water will flow from that particular cell based on the topography of the landscape. Select *fill* as the input flow direction raster and save the output raster as *flow_direction*.

3.4.3. Flow accumulation tool

The flow accumulation tool calculates the flow into each cell by identifying the upstream cells that flow into each downstream cell. This step is also done based on the landscape topography of the area. Select *flow_direction* as the input raster and save the output flow accumulation as *flow_accumulation*.

3.4.4. Raster calculator tool

Raster calculator builds and executes a single map Algebra expression using Python syntax in a calculator-like interface. Take *flow_accumulation* and assign threshold as ≥ 3000 . Give the output name as *raster_calculator*. Then, all the accumulations which are >3000 and <3000 will assign in separate grid codes.

3.4.5. Stream order tool

Stream order assigns a numeric order to segments of a raster representing branches of a linear network. Set *raster_calculator* as input for stream raster, *flow_direction* as the input for flow direction raster and name the output raster as *stream_order*. Strahler method of stream ordering is opted.

3.4.6. Stream to feature tool

It converts a raster representing a linear network to features (polyline) representing the linear network. The DEM was processed using Hydrology tool. The input is set as *stream_order*, *flow_direction* as input for flow direction raster and output as *Stream_polygon*. The values of different morphological parameters are found in the attribute table of this output file.

3.4.7. Line density tool

Line density calculates a magnitude per unit area from polyline features that fall within a radius around each cell. The input polyline feature is set as *Stream_order*, population field is set as grid code and output as *drainage_density*. The cell size is given as 30 m and units of the area is set as km². The environment (processing extent and raster analysis) is set as *Dapoli* shape file.

3.4.8. Slope tool

DEM from Cartosat 1 is to be used as the basic data for slope map generation. The slope of the area is determined from Spatial Analyst Tool Surface Slope. DEM is set as the input raster and output raster is set as *Slope* and measured in percentage. In the environments, the processing extent and raster analysis are set as DEM file. The generated output map is then reclassified into 5 classes.

3.8. Morphometric analysis

Morphometric analysis of the watershed is the best method to identify the relationship of various aspects in an area. Watershed is a natural hydrological entity from which surface runoff flows to a defined river, drain, channel or stream at a particular point. Watershed analysis based on morphometric parameters is very important for watershed planning since it gives an idea about the basin characteristics regarding soil condition, runoff characteristics, slope, topography, surface water potential, etc. The morphometric analysis of the watershed helps to know the aspects of linear, areal and relief parameters.

3.8.1. Linear aspects of the watershed

Linear aspects include the measurements of linear features of drainage like stream order (U), bifurcation ratio(R), mean stream length (L_{sm}), stream length ratio (R_L), etc. The linear aspects of the drainage basin are discussed below.

Stream order (U)

Stream ordering is the first step of quantitative analysis of the basin. It is a method of assigning a numeric order to links in a stream network. This order is a method for identifying and classifying types of streams based on their number of tributaries. A first order stream is an unbranched tributary and a second order stream is formed by two or more second order streams and so on. The highest order stream is called as Trunk.

Stream number

The total number of streams present in given stream order is called as Stream number.

Stream length (L_u)

The total length of individual stream of each order is the stream length of that order.

Mean stream length (L_{um})

Mean stream length is obtained by dividing the total length of stream of an order (L_u) by total number of segments in the order (N_u). It is a dimensionless property revealing the characteristic size of components of a drainage network and its contributing watershed surface (Strahler, 1964). The L_{um} values varies from basin to basin as it depends on the size and topography of the basin. Strahler (1964) indicated that the L_{um} is related to the size and associated surfaces. It is noted that the L_{um} value of any stream order is greater than that of the lower order and less than that of its next higher order in the basin.

$$L_{um} = \frac{L_u}{N_u} \dots\dots\dots (3.1)$$

Stream length ratio (R_L)

Stream length ratio is defined as the ratio of total length of stream of any order (L_u) to the average length of stream of the next lower order (L_{u-1}).

$$R_L = \frac{L_u}{L_{u-1}} \dots\dots\dots (3.2)$$

Bifurcation ratio (R_b)

The ratio of number of segments of a given order N_u to the number of segments of the next higher order N_{u+1} is termed as Bifurcation Ratio (R_b). It is a dimensionless property and generally ranges from 3 to 5. The lower values of R_b characterize less structural disturbances (Strahler, 1964) and higher values of R_b indicates strong structural control on the drainage pattern. A circular basin is likely to have low R_b whereas an elongated basin is likely to have high R_b .

$$R_b = \frac{N_u}{N_{u+1}} \dots\dots\dots (3.3)$$

3.8.2. Areal aspects of the watershed

Areal aspects of geomorphological study of watershed includes form factor, elongation ratio, circulatory ratio, drainage density and stream frequency.

Form factor (F_f)

Form factor is a dimensionless ratio of watershed area (A) to the square of the length of the watershed (L_b). The value of form factor varies from 0 (highly elongated shape) to 1 (perfect circular shape). Smaller the value of form factor, more elongated will be the watershed and flows for longer duration. Higher the value of form factor, circular is the watershed and flows for shorter duration.

$$F_f = A / L_b^2 \dots\dots\dots (3.4)$$

where, A = Area of the watershed

L_b = Length of basin

Elongation ratio (R_e)

The ratio of diameter of a circle of the same area as the basin (A_w) to the maximum basin length (L). It is a dimensionless quantity. It is a measure of shape of the basin and depends on climatic and geologic conditions. Generally, the elongation ratio value is categorized into two classes, i.e., the lower value which means elongated watershed and higher value which means circular watershed. R_e is also categorized into 4 classes as elongated (<0.7), less elongated (between 0.7 to 0.8), oval (between 0.8 to 0.9) and circular (> 0.9). Higher elongation ratio values have high infiltration capacity and low runoff, whereas elongation ratio having low value have circular basin is more efficient in the discharge of runoff than an elongated basin.

$$R_e = \frac{2}{L} \times \sqrt{\frac{A_w}{\pi}} \dots\dots\dots (3.5)$$

Circulatory ratio (R_c)

Circulatory ratio is the ratio between the area of watershed to the area of the circle having the same circumference as the perimeter of the watershed. It is a dimensionless property. R_c is more influenced by length, stream frequency, land cover, climate, relief, geological structures and slope of the basin. It ranges from 0 (for a line) to 1 (for a circle). Low value indicates youth stage, medium value indicates mature stage and high value indicates older stages of the tributaries in the basin.

$$R_c = \frac{4 \times A \times 3.14}{P \times P} \dots\dots\dots (3.6)$$

where, A_c = area of circle having equal perimeter as the perimeter of watershed

P= perimeter of the watershed (km)

Drainage density (D_d)

Drainage density is defined as the ratio of total length of all streams (L) of all orders within a watershed to the total area of the watershed (A). Low drainage density indicates the ground water potential of an area due to its relation with surface runoff and permeability. Low drainage density generally results in areas of permeable sub soil material, dense vegetation and low relief (Nag 1998) where as high drainage density is the resultant of impermeable subsurface material, sparse vegetation and mountainous relief. Low D_d leads to coarse drainage texture while high D_d leads to fine drainage texture.

$$Dd = \frac{\sum_{i=1}^K L}{A} \dots\dots\dots (3.7)$$

where, D_d = Drainage density

K = Principal order stream

A = Area of the watershed

Stream frequency (F_s)

Stream frequency is the total number of channel segments of all stream orders (N_u) per unit area (A_w) (km⁻²). High F_s points to a large surface runoff, steeper ground surface, impermeable subsurface, sparse vegetation and high relief conditions while low stream frequency indicates high permeable geology and low relief.

$$F_s = \frac{Nu}{Aw} \dots\dots\dots (3.8)$$

3.8.3. Relief aspects of the watershed

Relief aspects of the watershed includes basin relief, relief ratio, relative relief and ruggedness number.

Basin relief (R)

Basin relief is the difference between highest (H) and lowest (h) points in a watershed. The low relief value indicates high gravity of water flow, high infiltration rate and low runoff conditions while high relief value indicates low gravity of water flow as well as infiltration into the ground and high runoff conditions.

$$R = H - h \dots\dots\dots (3.9)$$

Where, H = maximum elevation (m)

h = minimum elevation (m)

Relief ratio (R_h)

Relief ratio is defined as the ratio between the total relief of a basin (H) and the longest dimension of the basin parallel to the main drainage (L). It is a unitless

parameter. It measures overall steepness of the watershed and is also considered as an indicator for the intensity of erosion which occurs in the watershed. Higher values of relief ratio indicate steep slope and high relief while the lower values indicate the presence of basement rocks that are exposed in the form of small ridges and mounds with lower degree of slope.

$$R_h = \frac{H}{L} \dots\dots\dots (3.10)$$

where R_h = relief ratio

H = total catchment relief (km)

L = maximum length of the catchment (km)

Ruggedness number (R_n)

Strahler (1964) defined Ruggedness number is the product of watershed relief (H) and drainage density (D_d). It usually combines its slope steepness with its length. Extremely high values of R_n occur when slopes of the basin are not only steeper but long as well. Low values of R_n indicate low erosion intensity in the basin.

$$R_n = H \times D_d \dots\dots\dots (3.11)$$

where R_n = ruggedness number

H = watershed relief (km)

D_d = Drainage density (km/km^2)

3.6. Land Use-Land Cover (LULC)

Land use/Land cover maps play a significant role in planning, management and monitoring programs from local level to national level. This type of information provides a better understanding of land utilization aspects and it plays an important role in the formation of policies and programs required for development and planning. LULC maps of an area provide information to understand the current landscape.

In the present study, LULC of the area of interest is classified based on supervised classification in ArcGIS. The Landsat-8 OLI satellite image is downloaded from USGS Earth Explorer for the study. Landsat-8 carries Operational Land Imager (OLI) and Thermal Infrared Sensor (TIRS) science instruments. These two sensors provide seasonal coverage of the global land at a spatial resolution of 30 m (Visible, NIR, SWIR), 100 m (thermal) and 15 m (panchromatic). It has 11 bands of which band 1,2,3,4,5,6,7,8,9 are scanned by OLI and band 10,11 by TIRS sensors. The Table 3.1 shows the interpretation of Landsat-8 OLI satellite image.

Table 3.1: Landsat-8 OLI Interpretation keys

S. No	LULC	Tone	Size	Shape	Texture	Association
1	Agricultural land	Dark red	Varying	Irregular	Fine to medium	Agricultural land
2	Forest	Bright red	Varying	Irregular	Coarse with mottling	Outskirts of agricultural land
3	Settlement	White	Varying	Definite	Coarse	Streets
4	Barren land	Creamy white	Varying	Irregular	Coarse with mottling	Agricultural land
5	Water body	Dark blue	Varying	Irregular/ Definite	Smooth	Agricultural land/ Built-up area/ Forest

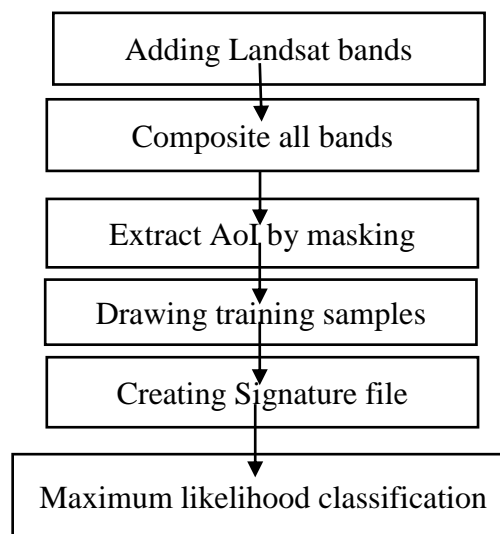

Figure 3.3: Flowchart showing the process of Maximum likelihood classification in ArcMap

The first 7 bands of Landsat 8 were added in ArcMap using the add data tool. Then navigate to Geoprocessing > Arc Toolbox > Data Management Tools > Raster > Raster Processing > Composite Bands. All the seven bands were selected in sequence as input raster. The name and the output location were specified and OK. Then the Multi-band raster from Landsat 8 is created. Figure 3.3 shows the process of Maximum likelihood classification in ArcMap.

Then the study area raster was extracted by using Extract by mask tool. In ArcMap navigate to Geoprocessing > Spatial Analyst Tool > Extraction > Extract by Mask. The input raster was set as the composite band layer, input raster or feature mask

data was set as the study area shape file and output raster name and location were specified.

The next step is adding training samples. In ArcMap, select Image classification by right clicking on the blank space on toolbar. The image classification toolbox provides a user-friendly environment for creating training samples and signature files for supervised classification. The tools and buttons available on the toolbar are Training sample manager, Clear Training samples, Training Sample Drawing Tools and Select Training Sample. The image layer was chosen in the layer list and draw polygon was selected. In the map display, the area that belong to the known class was identified. Five classes named built-up area, water body, agriculture, forest and barren land were created. Next a signature file was created and all these training samples were saved in it. Then Maximum likelihood classification was selected and input raster bands was set as extracted area of interest, input signature file was set as signature file, output name and location were given. Then the final LULC raster is generated.

The area and percentage of area covered is calculated by converting from raster to vector from the Conversion tools.

3.7. Geology

The data was collected from Bhukosh which is a gateway to all geoscientific data of Geological Survey of India (GSI). The shapefiles of study area and geology data were added in ArcMap. The area of interest was clipped using clip tool from Geoprocessing in menu bar. Both the layers must be georeferenced first. Then, the input feature was set as geology, clip feature as shape file of the study area and in output feature class name and location was given. The geology map was then generated. This was then converted to raster using polygon to raster tool with 30 m resolution.

3.8. Geomorphology

The geomorphology data was collected from Bhukosh website which is a gateway to all geoscientific data of GSI. The shape files of the area of interest and geomorphology data were added in ArcMap using Add data tool. The study area was clipped using Clip tool from Geoprocessing in menu bar. The input feature was set as geomorphology shape file, clip feature as study area and in output feature class name and location was given. The geomorphology map was then generated. This layer was converted to raster using polygon to raster tool with 30 m resolution.

3.9. Lineaments

The lineament data was collected from Bhukosh website which is a gateway to all geoscientific data of GSI. The shape files of the area of interest and lineament data were added in ArcMap. The study area lineaments were clipped using Clip tool from Geoprocessing tool bar. The input feature was set as lineament shape file, clip feature as study area and in output feature class name and location was given. Then lineament map was generated. Then using the line density tool, the lineament layer is converted to lineament density in raster format.

3.10. Soil

The soil map was collected from ESDAC website and added in ArcMap. It was first georeferenced using tehsil boundary shape file as datum. The soil map of study area is digitized, rasterized and clipped using shapefile in ArcMap 10.2. Then with respect to soil groups, the hydrological and textural classes were generated. The class details of each number were found out from the legend and edited in the attribute table. This polygon is converted to raster having 30 m resolution.

3.11. Rainfall

The annual rainfall data from 1991-2020 (30 years) of Ratnagiri district was collected from maharains.gov website and average annual rainfall values are tabulated as shown in Appendix-II. These values had been imported to ArcMap as .csv (comma separated value) file. The shape file of boundary of Ratnagiri district and the point data which contains rainfall values were added using Add data button in ArcMap. In the tool bar of ArcMap, go to Geoprocessing > Environments and set the processing extent and raster analysis as the shape file layer. Then in the Arc toolbox > Spatial Analyst Tool > Interpolation > Kriging. In the Kriging dialog box, the input was given as point data which contains rainfall values. The z value field was chosen as average rainfall and output location was specified in the output surface raster and OK. Then the generated layer was reclassified using Symbology option into 4 classes. At last, the study area map has been extracted by using the extract by mask tool.

3.12. Runoff depth

Arc SWAT is an ArcGIS-ArcView extension and GUI for SWAT (Soil and Water Assessment Tool). SWAT model is developed by United States Department of Agriculture-Agriculture Research Services (USDA-ARS). It is used for watershed modellings like impact of land management practices on water, sediment and agricultural chemical yields in large, complex watersheds with varying soils, land use

and management conditions over long periods of time, etc. It is also used for estimating available water resource, managing check dams, quantifying the impacts from land use changes on runoff, modelling the long-term impact of management practices. In the present study, SWAT model was used to generate runoff depth in the study area.

The hydrometeorological data is needed to run the model. The major hydrometeorological data includes DEM, soil map, land use/land cover map, slope map and meteorological data which contains rainfall (mm), maximum and minimum temperature (°C), wind speed (m/sec), relative humidity (%) and solar radiation. The procedure followed for modeling using SWAT is shown in Figure 3.4.

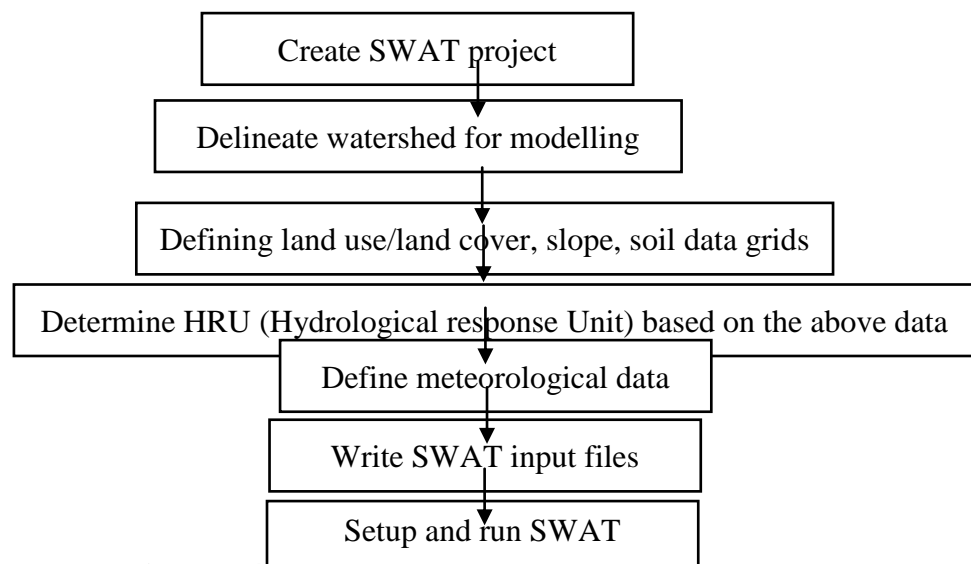

Figure 3.4. Procedure to run SWAT model

3.13. Site suitability analysis

Site suitability analysis is a type of analysis used in GIS to determine the best place to locate something (Patel *et al.*, 2012). Weighted overlay site selection analysis allows users to rank raster cells and assign a value to each layer. For performing site selection analysis various criteria from GIS software will rate the best ideal sites. Site selection analysis can be performed with vector or raster data but weighted overlay site selection is most widely used using raster data. Weighted site selection is an important site selection method because it includes options for viewing next-best sites.

3.13.1. Weighted overlay analysis

There is standard workflow that should be followed in order to use weighted site selection. The workflow usually begins with defining a problem or criteria such as

locating some potential sites. The next step is to gather all data and create raster surfaces which are to be used in the analysis. The third step is by reclassifying the layers, weighting them and then overlaying the output layers with background information to see the best potential sites. Reclassification is important because it is used to simplify the interpretation of raster data by changing a single input value into a new output value (ESRI). By using reclassification, they are all based on the same ranking scheme that can be used to compare and rank the least and most suitable sites. Weighing layers is also critical step in weighted site selection because it allows to place varying levels of importance on different parameters. Weights are assigned as different percentages that will add up to 100%. The suitable values in between 1 and 8 for all eight parameters are to be given by taking their hydrogeological importance into account based on literatures reviewed. The highly influencing parameter will be assigned the value of 8 and the least influencing parameter will be assigned the value of 1. The intermediate values are to be given accordingly. Then the suitable area in the watershed map will be generated.

3.13.2. Potential sites for soil and water conservation structures

The multi-layer integration of land use/land cover, slope, drainage density, runoff will give the suitability areas for identifying soil and water conservation structures like check dams, percolation tanks or nala bunds and farm pond with lining. By creating separate point shape files in ArcMap for each structure, the locations were selected based on the technical guidelines which were shown in Table 3.2.

Table 3.2: Decision rules for selection of suitable locations for soil and water conservation structures

Type of structure	Slope	Runoff	Stream order	LULC
Check dams	<10%	High to low	3 rd , 4 th	River/Stream
Percolation tanks	0-3%	High to low	2 nd and 3 rd	Barren land or scrub land
Farm Pond with plastic lining	1-3%	Moderate	3 rd , 4 th and 5 th	Agricultural land, barren land

3.13.3. Check dam

Check dams are very popular type of water harvesting structures. They are small dams and usually constructed of rock, sediment retention fibre rolls, pea gravel bags or sand bags across a natural or manmade channel or drainage ditch. They are

constructed to reduce the runoff velocity and reduces erosion. Check dam prevents the wastage of rain water discharging into the sea or ocean and provides fresh water bodies for local usage. The following formulas were used to design check dam.

Design of check dam:

Simple Kresnik formula,

$$Q = 25 A^{1/2} \dots\dots\dots (3.12)$$

Where, Q = maximum discharge of the stream (m³/sec)

A= area of catchment (km²)

Discharge capacity is given by the following formulae,

$$Q = 1.75 LH^{3/2} \dots\dots\dots (3.13)$$

where Q= runoff (m³/sec)

L = length of crest (m)

H = depth of flow (m)

Freeboard, f = 0.3 m

Height of wing wall above crest, d = H + f

$$\begin{aligned} \text{Length of apron} &= 0.75 \times (\text{Fall} + \text{Height of wing wall above crest}) + \text{fall} \\ &= 0.75 \times (h + d) + h \end{aligned}$$

3.13.4. Percolation tank

Percolation tank is a small, traditional and popular water storage structure which serves the purpose of recharging ground water. These are generally constructed across streams or nalla in order to impound a part of run-off water (IMSD, 1995). Percolation tanks are water bodies submerging a highly permeable land area so that the surface runoff will percolate and recharge the ground water storage. These are usually constructed on second and third order streams. The following procedure is used to design the percolation tank.

Design of percolation tank:

Volume of runoff,

$$R = \frac{CPA}{1000} \dots\dots\dots (3.14)$$

where, C = curve number

P = precipitation (mm)

A = catchment area (ha)

R = runoff

Volume of tank,

$$V = \frac{d}{6} \times (A_0 + 4A_1 + A_2) \dots\dots\dots (3.15)$$

where, A_0 = bottom surface area

A_1 = mid-section area

A_2 = top surface area

d = depth of tank

The detailed calculation for design of percolation tank is shown in Appendix – VI.

3.13.5. Farm pond with plastic lining

Farm ponds are reservoir like water harvesting structures that are constructed for the purpose of storing rain water and surface runoff in a catchment. They solve the purpose of farm needs like supply of water for irrigation of crops, cattle feed, fish production, etc. They also play a key role in flood control by constructing them in large numbers in a catchment and they also have a significant role in rainfed farming. They are also used for irrigating rabi and summer crop using micro irrigation. The following procedure is followed for design of farm pond.

Table 3.3: Recommended side slope

S. No.	Soil type	Slope (horizontal: vertical)
1	Clay	1:1 to 2:1
2	Clay loam	1.5:1 to 2:1
3	Sandy loam	2:1 to 2.5:1
4	Sandy	3:1

(Source: Critchley *et al.* 1991)

Design of farm pond:

In the present study farm pond has been proposed for irrigating area of 10 ha.

Assume, 5 ha area – Fruit crop

5 ha area – Vegetable crop

So, water requirement for 5 ha vegetable crop is about 2000 m³ and

Water requirement for 5 ha fruit crop is about 1000 m³.

Total amount of water requirement is 3000 m³.

Assume, depth of farm pond = 3 m

$$\text{Volume of farm pond (V)} = \frac{A+4B+C}{6} \times D \dots\dots\dots (16)$$

where, A = top surface area (m²)

B = mid-section area (m²)

C = bottom surface area (m²)

D = average depth of pond (m)

The detailed calculation for design of farm pond is shown in Appendix - VII

3.14. Estimation of Water Budget

Water budget

A water budget is a hydrological tool used to quantify the flow of inflow and outflow water of a system. It is an accounting of all the water that flows into and out of an area. The concept behind a water budget is that the rate of change of water stored in a specific area is balanced by the quantity and rate at which water flows into and out of that specific area. A water budget is calculated for a specified period of time and calculated for a range of conditions.

The water budget is expressed as an equation as follows:

$$P = E_T + E_{pan} + R_s + G_s + \Delta S \dots\dots\dots (17)$$

where, P= precipitation

E_T = evapotranspiration by Hargreaves equation

E_{pan} = pan evaporation

R_s = surface runoff

G_s = ground water recharge/ sub-surface recharge

ΔS = change in soil moisture storage

The first three terms of the water budget equation, precipitation, evaporation and evapotranspiration are natural processes that are not affected by development. But changes in land use can notably affect surface runoff and sub-surface flow.

Components

Precipitation (P)

Precipitation is the primary water input to the hydrologic cycle and is evaluated for all water budget calculations. It is defined as the falling of water from the atmosphere in form of rain, snow, mist, etc on the earth. It is measured in the form of depth on land surface. The precipitation data was collected from Agrometeorological Department, DBSKKV, Dapoli. The daily weather data of the year 2020 was procured and average annual rainfall was found.

Evapo-transpiration (E_T)

Evapo-transpiration is the process by which water is transmitted from the earth surface to the atmosphere by evaporation and by transpiration from plants through stomata in the plant leaves.

In the present study, Hargreaves equation was used to estimate the evapo-transpiration. The equation is as follows:

$$E_T = 0.0023 \times R_a \times (T_{\max} - T_{\min})^{0.5} \times (T_{\text{mean}} + 17.8)$$

..... (18)

Where, E_T = Evapo-transpiration, mm/day

R_a = extra-terrestrial radiation, mm/day

T_{\max} = maximum air temperature, °C

T_{\min} = minimum air temperature, °C

T_{mean} = mean air temperature, °C

The temperature values are taken from the agro-climatic data which is procured from Agrometeorological Department, DBSKKV, Dapoli. T_{\max} , T_{\min} , T_{mean} values are selected from the month of July as this month recorded the highest rainfall in the year 2020. The value of R_a was calculated from the values of mean-monthly extra-terrestrial radiation table from A.M.Micheal text book.

Pan-evaporation (E_{pan})

Pan evaporation is commonly measured by pan evaporimeter. The E_{pan} value was collected from the Agrometeorological Department, DBSKKV, Dapoli. The average E_{pan} value was calculated from the E_{pan} data of July month as it recorded the highest rainfall in the year 2020.

Surface runoff (R_s)

It is the part of rainfall which enters the streamlets immediately after the occurrence of rainfall. When all losses such as interception, depression storage, infiltration, etc are satisfied and if still rainfall continues with the rate greater than infiltration rate, then excess waters flow on the ground surface which tends to move due to slopy lands, is known as overland flow. After sometime, the overland flow joins the streams, nalas, channels, etc which is called as surface runoff.

The surface runoff value was taken from the runoff thematic map which was generated by using ArcSWAT tool in ArcGIS.

Ground water recharge (G_s)

For calculating ground water recharge, Krishna Rao formula (1970) is used.

The equation is as follows:

$$R = K \times (P - X)$$

$$R = 0.35 \times (P - 600)$$

Where, R = ground water recharge due to annual precipitation, mm/yr

P = Annual precipitation, mm/yr

This formula is used for areas with annual rainfall above 2000 mm.

Soil moisture storage (ΔS)

Soil moisture storage is the total amount of water that is stored in the soil within the root zone area of plant.

V. SUMMARY AND CONCLUSIONS

A study was conducted for planning and designing of soil and water conservation structures in Dapoli tehsil, using Remote Sensing and GIS. The study area lies between 17°34' to 17°56' N latitude and 73°03' to 73°20' E longitude. Dapoli is a tehsil in Ratnagiri district of Maharashtra, India having an annual average rainfall of 3500 mm.

In the present study, an effort has been made to analyze the geomorphological characteristics of the watershed as an easy task using ArcGIS which was cumbersome using traditional methods. The geomorphological characteristics includes linear aspects such as stream order, stream length ratio, mean stream length and bifurcation ratio has been determined using ArcGIS. The results showed that, the watershed is dominated by 6th order stream, having total 3720 streams in the watershed. The average stream length ratio and average bifurcation ratio were found as 0.73 and 2.27 respectively. The aerial aspects such as area, perimeter, form factor, circulatory ratio, elongation ratio, drainage density were determined using ArcGIS tool. The area of basin was 910.40 km² and perimeter of the basin was 208.12 km. The form factor, circulatory ratio, elongation ratio, drainage density values were 0.5, 0.26, 0.8, 1.1 km/km² respectively. The relief aspects were basin relief, relief ratio and ruggedness number and the values were found as 480 m, 11.34 and 528 respectively.

Further with aid of Remote Sensing and GIS thematic maps like drainage density, slope, land use/land cover, rainfall, geomorphology, geology, lineament density, runoff depth were generated. The runoff depth distribution was determined using SWAT model. By integrating all these thematic maps, weighted overlay analysis was performed to identify the suitable soil and water conservation structures in the study area. The appropriate conservation structures were located according to the criteria discussed in Chapter 3 in Table 3.2.

The study revealed that, watershed has the scope for construction of various soil and water conservation structures. There were 120 potential sites for conservation structures in the study area. Check dam, farm pond with plastic lining and percolation tanks were proposed. Check dams were more in number i.e., 71 numbers, followed by farm ponds with plastic lining 36 numbers and percolation tank 13 numbers. The use of these percolation tanks also increases the groundwater recharge besides providing supplementary irrigation. The design of these conservation structures was carried out

based on land use, slope and runoff of the area. The water balance estimation was also performed for the study area.

Conclusions

From the present study, the following conclusions has been drawn:

1. The value of mean bifurcation ratio in the study area is 2.27 and the elongation ratio was found as 0.8.
2. The value of form factor is 0.5 and the value of drainage density is 1.1 km/km².
3. The basin relief is found as 480 m.
4. The geomorphology of the watershed is mostly dominated by moderately dissected plateau (72.87%).
5. From the land use/land cover study, maximum area of 47% (427.8 km²) of Dapoli tehsil was found under forest cover.
6. Hydrologic soil group B is more dominated in the watershed.
7. The weighted overlay analysis provided 120 potential sites for soil and water conservation structures in Dapoli tehsil.
8. The suitability of check dam, farm pond with lining and percolation tanks were suggested accordingly.
9. The maximum number of sites (59%) showed suitability for Check dams, 30% and 11% were recommended for Farm Pond with plastic lining and percolation tank respectively.
10. The use of Remote Sensing and GIS was useful and helped in planning suitable sites in the study area by generating thematic maps like slope, geology, lineament density, land use/land cover, geomorphology, soil, runoff, etc.

Thus, it is apparent that remote sensing and GIS are highly beneficial for planning and designing of soil and water conservation structures as its less time consuming compared to conventional methods as it reduces time of field study and money.

VI. BIBLIOGRAPHY

- Abhay, M.V., Khare Y.D and N.C. Mondal. (2013). Identification of Water Conservation Sites in a Watershed (WRJ-2) of Nagpur District, Maharashtra using Geographical Information System (GIS) Technique. *J Indian Soc Remote Sens*, 41(3), 619-630.
- Abhishek J., Manjeet S., Singh P.K. and Yadav K.K. (2020). Morphometric Analysis of Kakan Watershed using Remote Sensing and GIS. *International Journal of Current Microbiology and Applied Sciences*. 9(12):2824-2833.
- Alka S., Florian S., Annette E. and Andreas G. (2016). Water Budget Analysis within the surrounding of Prominent Lakes and Reservoirs from Multi-Sensor Earth Observation Data and Hydrological Models: Case Studies of the Aral Sea and Lake Mead. *Remote Sensing*. 8:953.
- Anbazhagan S., Ramasamy S.M. and Gupta D.S. (2005). Remote sensing and GIS for artificial recharge study, runoff estimation and planning in Ayyar basin, Tamil Nadu, India, *Environmental Geology*, 48(2),46-49.
- Aravinda P.T. and Balakrishna H.B. (2013). Morphometric analysis of Vrishabhavathi watershed using Remote sensing & GIS. *International Journal of Research in Engineering and Technology*, 2(8).
- Arjita, S., Mahesh K. J. and Sudhir K. (2017). Optimum Site Selection of Water Harvesting Structures Using Geospatial Analysis and Multi Criteria Evaluation Techniques, Hydro-2017 International, L.D. College of Engineering Ahmedabad, India.
- Arnab S., Manti P., Sateesh K., Pingale S.M., Samee A., Goyal V.C. and Rathore D.S. (2018). Identification of potential sites for water harvesting structures using Geospatial techniques and multi-criteria decision analysis. *The International Archives of the Photogrammetry, Remote Sensing and Spatial Information Sciences*, 42(5).
- Bansod Dr. RD and Ajabe GS. (2018). Determination of geomorphological characteristics of Karpri-Kalu watershed using GIS techniques. *Journal of Pharmacognosy and Phytochemistry*, 7(1), 1940-1944.
- Bansode A. and Patil K.A. (2014). Estimation of Runoff by using SCS Curve Number Method and ArcGIS. *International Journal of Scientific & Engineering Research*, 5(7):1283- 1287.

- Biswajit D., Sanjay J., Surjeet S. and Praveen T. (2019). Evaluation of multisite performance of SWAT model in the Gomti River Basin, India. *Applied water Science*. 9:134
- Bhavana N. U. (2015). Morphometric analysis of Andhale watershed, Taluka Mulshi, District Pune, India. *Appl Water Sci*, 7:2231-2243.
- Bose C.A.S., Sridhar P., Giridhar M.V.S.S. and Viswanadh G.K. (2012). Morphometric Analysis at Miniwatershed Level using GIS. *International Journal of Civil Engineering Research*, 3(3), 157-171.
- Chang S.W. and Chung I.-M. (2021). Water Budget Analysis Considering Surface Water- Groundwater Interactions in the Exploitation of Seasonally Varying Agricultural Groundwater. *Hydrology*, 8(60).
- Chirag S.B., Dr. Singh N.P., Mori P.R., Dr. Indra P. and Khalid M. (2015). Estimation of Surface Runoff for Ahmedabad Urban Area using SCS-CN method and GIS. *International Journal of Science Technology & Engineering*, 1(11):411-416.
- Chopra, R., R. Dhiman and P.K. Sharma. (2005). Morphometric analysis of sub watersheds in Gurdaspur District, Punjab using Remote Sensing and GIS techniques. *Journal of the Indian Society of remote Sensing*, 33(4):531-539.
- Critchley W., Siegert K. and Champman C. (1991). A Manual for the Design and Construction of Water Harvesting Schemes for Plant Production, FAO, Rome.
- Dharmishtha N. and Pramendra D. (2014). Geomorphological Analysis of a part of Meghnagar area, Jhabua District, Madhya Pradesh, India. *International Journal of Fundamental & Applied Research*, 2(7), 27-37.
- Dipika B., Deepika M. and Dipali K. (2014). Soil moisture, Production and water use efficiency. *Conservation Practices*.
- Girish M.K., Agarwal A.K. and Rameshwar Bali. (2008). Delineation of potential sites for water harvesting structures using Remote Sensing and GIS. *Journal of the Indian Society of Remote Sensing*, 36:325-336.
- Gizachew K. and Berhan G. (2018). Hydro-geomorphological characterization of Dhidhessa River Basin, Ethiopia. *International Soil and Water Conservation Research*, 6(2018):175-183.
- Gowd, S.S. (2004). Morphometric analysis of Peddavanka basin, Anantapur district, Andhra Pradesh, India. *Journal of Applied Hydrology*, 17(1):1-8.

- Gulshan M. and Rajeshwari M. (2012). GIS Based Delineation of Micro-watershed and its Applications: Mahendergarh District, Haryana. *Journal of Human Ecology*, 38(2), 155- 164.
- Harish C.P., Parul B. and Sarvesh P. (2014). Site suitability Analysis of Water Harvesting Structures using Remote Sensing and GIS- A case study of Pisangan Watershed, Ajmer District, Rajasthan. *The International Archives of the Photogrammetry, Remote Sensing and Spatial Information Sciences*, 50(8).
- Harshika A.K. and Ingle S. (2012). Land Use land Cover Classification and Change Detection Using High Resolution Temporal Satellite Data. *Journal of Environment*, 1(4):146-152.
- Hasan M.S., Kalyan A. and Sowmya B. (2017). Morphometric analysis using Remote Sensing and GIS. *Journal of Civil Engineering and Environmental Technology*, 4(1), 17-22.
- IMSD, (1995). Integrated Mission for Sustainable Development technical guidelines, National Remote Sensing Agency, Department of Space, Government of India, Hyderabad.
- Kailash N, Kumar P.S.D. and Dwivedi S.B. (2013). Geomorphological Characteristics of Varuna Watershed using GIS and Remote Sensing Techniques. *2nd International Conference on Emerging Trends in Engineering & Technology*.
- Kevin E.T., Smith L., Qian T., Aiguo D. and John F. (2006). Estimates of the Global Water Budget and its Annual Cycle Using Observational and Model Data. *Journal of Hydrometeorology-Special Section*. 8:758-769.
- Khalid J.A.M. and Aysar M.A.S. (2017). Selection of Suitable Sites for Water Harvesting Structures in a Flood Prone Area Using Remote Sensing and GIS- Case Study. *Journal of Environment and Earth Science*. 7(4), 91-100.
- Krishna R. (1970). Hydrometeorological Aspects of Estimating Ground Water Potential. *Seminar on Ground Water Potential in Hard Rock Areas, Bangalore, Geological Society of India*, 1(1):1-18.
- Kudnar N.S. and Rajasekhar M. (2019). A study of the morphometric analysis and cycle of erosion in Wainganga Basin, India. *Modeling Earth Systems and Environment*.
- Kuldeep P. and Upasana P. (2012). Quantitative Geomorphological Analysis of a Watershed of Ravi River Basin, H.P. India. *International Journal of Remote Sensing and GIS*, 1(1),47-62.

- Mani A., Kranthi Kumar Ch. and Sai G.R. (2018). Mapping of soil erosion for soil and water measures in Kolleru lake catchment area. *Indian Journal of Soil Conservation*, 46(2), 171-180.
- Manivannan S., Kasthuri T.V. and Khola O.P.S. (2017). Soil and water conservation in India: Strategies and research challenges. *Journal of Soil and Water Conservation*, 16(4):312- 319.
- Michael A.M. (2007). Irrigation Theory and Practice. Vikas Publishing House Pvt. Ltd. New Delhi, India.
- Miller V.C. (1953). A quantitative geomorphic study of drainage basin characteristics in the Clinch Mountain area, Virginia and Tennessee, Project NR 389-402, Technical report 3, Columbia University, Department of Geology, ONR, Geography Branch, New York.
- Nag, S.K. (1998). Morphometric Analysis Using Remote Sensing Techniques in the Chaka Sub Basins Purulia District, West Bengal. *Journal of Indian Society of remote Sensing*, 26, 69-76.
- Nanabhau S.K. and Rajasekhar M. (2019). A study of the morphometric analysis and cycle of erosion in Wainganga Basin, India. *Modelling Earth Systems and Environment*.
- Naser A.S., Karim S., Lida R. and Jalal Z. (2016). Land Use Change Detection Using Remote Sensing and GIS. *International Journal of Geological and Environmental Engineering*, 10(3).
- Noorkaratnam K., Srivastava Y. K., Rao V.V., Amminedu E. and Murthy K.S.R. (2005). Check dam positioning by prioritization of micro-watersheds using SYI model and morphometric analysis- remote sensing and GIS perspective. *Journal of India Society of Remote Sensing*, 33(1):25-38.
- Pande C.B., Patode R.S., Nagdeve M.B., Moharir K.N. and Dongardive M.B. (2018). Application of GIS and Remote Sensing for Water Conservation Planning and Management of the Purna watershed in Akola district of Maharashtra, Proceedings of 5th National Conference on Water, Environment & Society.
- Patel D.P., B.D. Mrugen N. Naresh and K.S. Prashant. (2012). Water harvesting structure positioning by using geo-visualization concept and prioritization of mini-watersheds through morphometric analysis in the lower Tapi Basin. *Journal of the Indian Society of Remote Sensing*, 40(2):299-312.

- Patil N.P., Kadale A.S. and Mhetre G.S. (2015). Assessment of Morphometric Characteristics of Karwadi_Nandapur Micro Watershed Using Remote Sensing and Geographical Information System. *International Journal of Scientific & Technology Research*. 4(4):175-179.
- Patode R.S., Pande C.B. Nagdeve M.B., Moharir K.N. and Wankhade R.M. (2017). Planning of Conservation Measures for Watershed Management and Development by using Geospatial Technology- A Case study of Patur Watershed in Akola District of Maharashtra. *Current World Environment*, 12(3):708-716.
- Pendke M.S., Asewar B.V., Samindre M.S., Ravindra C.G. and Narsimlu B. (2018). Water Budgeting of Babhulgaon Micro Watershed under Deficit Rainfall Years. *Indian Journal of Dryland Agricultural Research and Development*, 33(2):43-49.
- Prabuddh K.M., Aman R. and Suresh C.R. (2020). Land use and land cover change detection using geospatial techniques in the Sikkim Himalaya, India. *The Egyptian Journal of Remote Sensing and Space Sciences*, 133-143.
- Prafull S. and Jay K.T. (2013). Morphometric analysis of Morar River Basin, Madhya Pradesh, India, using remote sensing and GIS techniques. *Environ Earth Sci*, 68:1967-1977.
- Pramod M.K., Nagalakshmi K., Lakshmi P.T., Jayaraju N. and Lakshmana B. (2019). Land use and Land Cover Analysis using Remote Sensing and GIS: A Case Study in and around Bramhamgarimatam, Kadapa District, Andhra Pradesh, India. *SSRG- International Journal of Geoinformatics and Geological Science*, 6(1):16-20.
- Praveen R.S. and Prasad N.S.R. (2008). Integrated Land and Water Resources Conservation and Management-Development plan using Remote sensing and GIS of Chevella sub-watershed, R.R. District, Andhra Pradesh, India. *The International Archives of the Photogrammetry, Remote Sensing and Spatial Information Sciences*, 37:729-732.
- Praveen K.M. and Jayarama R.S.R. (2013). Analysis of Land Use/Land Cover changes Using remote Sensing Data and GIS at an Urban Area, Tirupati, India. *The Scientific World Journal*, 2013.
- Praveen K.R., Mohan K., Sameer M. Ahmad A. and Varun N.M. (2017). A GIS-based approach in drainage morphometric analysis of Kanhar River Basin, India. *Applied Water Science*. 7:217-232.

- Radha S. and Majeet S. (2019). Identification of potential sites for water harvesting structures in Gadela watershed using remote sensing and GIS. *Environment Conservation Journal*, 20(3):125-130.
- Rafiq A.H., Aadil H., Naseer A.D. and Sami U.B. (2013). Morphometric analysis of Vishav drainage basin using geo-spatial technology (GST). *International Research Journal of Geology and Mining*, 3(3):136-146.
- Rahaman M.F., Jahan C.S., Arefin R. and Mazumder Q.H. (2017). Morphometric Analysis of Major Watersheds in Barind Tract, Bangladesh: A Remote Sensing and GIS-Based Approach for Water Resource Management. *Hydrology*. 8(6):86-95.
- Ramakrishnan D., Durga Rao K. H. V. and Tiwari K.C. (2008). Delineation of potential sites for water harvesting structures through remote sensing and GIS techniques: a case study of Kali watershed, Gujarat, India. *Geocarto International*, 23(2):95-108.
- Rambabu P. and Jai S.G. (2014). Study of Watershed Characteristics using Google Elevation Service. *Conference Paper*.
- Ranjan B., Birendra N.G., Prasanta K.M., Biswapati M., Srinivas C.R., Dibyendu S., Das K., Anil K.S. and Lali M. (2015), Soil Degradation in India: Challenges and Potential Solutions. *Sustainability, MDPI, Open Access Journal*, 7(4):1-43.
- Rajini J., Kishore P. and Dhirendra K.S. 2020. Irrigation in India: Status, Challenges and options. *Journal of Soil and Water Conservation*, 18(4):354-363.
- Rekha V.B., George A.V. and Rita M. (2011). Morphometric analysis and micro-watershed prioritization of Peruvanthanam sub-watershed, the Manimala River Basin, Kerala, South India. *Environ Res Eng Manage*, 3(57):6-14.
- Sandeep Soni. (2016). Assessment of morphometric characteristics of Chakrar watershed in Madhya Pradesh India using geospatial technique. *Appl Water Sci*, 7:2089-2102.
- Satheeshkumar S., Venkateswaran S. and Kannan R. (2017). Rainfall-Rainfall estimation using SCS-CN and GIS approach in the Pappiredipatti watershed of the Vaniyar sub basin, South India. *Model Earth Syst. Environ.*, 3:24.
- Singh. J.P., Darshdeo S., and Litoria P.K. (2008). Selection of Suitable Sites for Water Harvesting Structures in Soankhad Watershed, Punjab using Remote Sensing and Geographical Information System (RS&GIS) Approach- A Case Study. *Journal of the Indian Society of Remote Sensing*, 37:21-35.

Sreedevi P.D., Subrahmanyam K. and Ahmed S. (2005). The significance of morphometric analysis for obtaining groundwater potential zones in a structurally controlled terrain. *Environmental Geology*. 47:412-420.

Strahler AN. (1964). Quantitative geomorphology of Drainage Basins and Channel Networks. In: Te Chow, Ven. (Ed.), Hand Book of Applied Hydrology, McGraw Hill Book Company, New York. 439-476.

Suresh R. (2005). Watershed Hydrology. Standard Publishers Distributors, New Delhi, India.

Tushar L., Balasubramani K. and Bindu B. (2018). Site Suitability analysis for establishing soil and water conservation structures using Geoinformatics- A case study of Chinnar watershed, Tamil Nadu, India. *Journal of Geomatics*, 12(2).

<https://www.soilmanagementindia.com/soil-erosion/check-dam/design-of-check-dam-with-diagram-erosion-control-soil-management/15650>

<https://www.who.int/news-room/fact-sheets/detail/drinking-water>

https://bhuvan.nrsc.gov.in/bhuvan_links.php

<https://earthexplorer.usgs.gov/>

<https://bhukosh.gsi.gov.in/Bhukosh/Public>

<https://esdac.jrc.ec.europa.eu/>

<https://www.dis-gis.org>

<https://globalweather.tamu.edu>

<https://www.usbr.gov/mp/arwec/water-facts-ww-water-sup.html>

VII. APPENDICES

APPENDIX I

Calculation of Geomorphological characteristics

I. Linear aspects of the watershed

1. Mean stream length (L_{um}) = $\frac{\text{length of order } u}{\text{no. of orders of } u}$

$$1^{\text{st}} \text{ Mean stream length} = \frac{523.4}{1771.1} = 0.29 \text{ km}$$

$$2^{\text{nd}} \text{ Mean stream length} = \frac{254.32}{956} = 0.26 \text{ km}$$

$$3^{\text{rd}} \text{ Mean stream length} = \frac{138.1}{538} = 0.25 \text{ km}$$

$$4^{\text{th}} \text{ Mean stream length} = \frac{45.54}{188} = 0.24 \text{ km}$$

$$5^{\text{th}} \text{ Mean stream length} = \frac{32.92}{214} = 0.15 \text{ km}$$

$$6^{\text{th}} \text{ Mean stream length} = \frac{10.92}{53} = 0.2 \text{ km}$$

2. Bifurcation ratio (R_b) = $\frac{Nu}{Nu+1}$

$$R_{b1} = \frac{1771}{956} = 1.85 \text{ km}$$

$$R_{b2} = \frac{956}{538} = 1.77 \text{ km}$$

$$R_{b3} = \frac{538}{188} = 2.86 \text{ km}$$

$$R_{b4} = \frac{188}{214} = 0.87 \text{ km}$$

$$R_{b5} = \frac{214}{53} = 4.03 \text{ km}$$

II. Areal aspects

1. Form factor (R_f) = $\frac{A}{L \times L}$

$$= \frac{910.404}{42.317 \times 42.317}$$

$$= 0.5$$

2. Circulatory ratio (R_c) = $\frac{4 \pi A}{P \times P}$

$$= \frac{4 * \pi * 910.404}{208 * 208}$$

$$= 0.26$$

3. Elongation ratio (R_e) = $\frac{2}{L} \sqrt{\frac{A}{\pi}}$

$$= \frac{2}{42.317} \sqrt{\frac{910.404}{\pi}}$$

$$= 0.8$$

4. Drainage density (D_d) = $\frac{\sum L}{A}$

$$= \frac{1005.2}{910.404}$$

$$= 1.104$$

5. Stream frequency = $\frac{\sum N}{A}$

$$= \frac{3720}{910.404}$$

$$= 4.08 / \text{km}^2$$

III. Relief aspects

1. Basin relief (R) = $H - h$

$$= 480 - 0$$

$$= 480$$

2. Relief ratio (R_r) = $\frac{R}{L_w}$

$$= \frac{480}{42.317}$$

$$= 11.342$$

3. Ruggedness number (R_n) = $R \times D_d$

$$= 480 \times 1.1$$

$$= 528$$

APPENDIX II

Ratnagiri district annual average rainfall from 1991-2020

Tehsil	Latitude	Longitude	Average annual rainfall (mm)
Chiplun	17.5319	73.5151	3387.56
Dapoli	17.7677	73.1910	3183.47
Khed	20.1630	77.8853	3110.63
Guhaghar	17.4641	73.1960	2816.08
Mandanghad	17.9876	73.2633	3369.98
Ratnagiri	16.9902	73.3120	3000.21
Sangameshwar	17.7871	73.5521	3663.47
Rajapur	16.6571	73.5211	3259.27
Lanja	16.8559	73.5417	3131.17

APPENDIX III

Daily maximum & minimum temperature and pan evaporation data of July, 2020

Date	T _{max}	T _{min}	E _{pan}
	(°C)	(°C)	(mm)
1-Jul-20	29.5	23.7	2.2
2-Jul-20	30.0	22.8	0.0
3-Jul-20	30.0	23.6	1.8
4-Jul-20	27.0	22.5	0.0
5-Jul-20	27.0	23.0	0.0
6-Jul-20	29.0	25.0	1.0
7-Jul-20	30.0	23.5	1.8
8-Jul-20	28.5	24.2	0.0
9-Jul-20	27.1	24.1	0.0
10-Jul-20	28.0	24.1	0.0
11-Jul-20	29.5	23.0	0.0
12-Jul-20	29.5	23.0	2.6
13-Jul-20	28.5	23.5	1.8
14-Jul-20	29.0	23.0	2.8
15-Jul-20	29.0	22.2	0.0
16-Jul-20	26.8	22.1	0.0
17-Jul-20	27.5	22.7	2.0
18-Jul-20	28.2	23.9	2.6
19-Jul-20	29.8	24.0	3.2
20-Jul-20	29.7	24.0	1.6
21-Jul-20	29.5	24.6	3.8
22-Jul-20	30.5	23.7	3.2
23-Jul-20	30.0	24.3	3.3
24-Jul-20	30.2	24.6	2.6
25-Jul-20	29.0	22.5	1.2
26-Jul-20	30.4	23.5	2.4
27-Jul-20	30.0	23.0	3.7
28-Jul-20	28.1	22.5	of
29-Jul-20	30.0	23.7	3.6
30-Jul-20	29.2	24.0	1.8
31-Jul-20	29.8	24.0	2.8

APPENDIX IV

Daily rainfall data of June, July, August, September and October of 2020

Date	Rain	Date	Rain	Date	Rain	Date	Rain	Date	Rain
	(mm)		(mm)		(mm)		(mm)		(mm)
1-Jun-20	0.0	1-Jul-20	3.8	1-Aug-20	6.4	1-Sep-20	3.0	1-Oct-20	0.0
2-Jun-20	1.0	2-Jul-20	124.6	2-Aug-20	44.2	2-Sep-20	1.6	2-Oct-20	0.0
3-Jun-20	26.0	3-Jul-20	21.8	3-Aug-20	27.8	3-Sep-20	0.0	3-Oct-20	0.0
4-Jun-20	107.2	4-Jul-20	156.4	4-Aug-20	121.2	4-Sep-20	0.0	4-Oct-20	21.0
5-Jun-20	103.8	5-Jul-20	144.2	5-Aug-20	98.0	5-Sep-20	4.0	5-Oct-20	3.0
6-Jun-20	3.6	6-Jul-20	6.8	6-Aug-20	140.2	6-Sep-20	0.0	6-Oct-20	0.0
7-Jun-20	4.6	7-Jul-20	27.0	7-Aug-20	62.6	7-Sep-20	8.2	7-Oct-20	0.0
8-Jun-20	45.8	8-Jul-20	77.6	8-Aug-20	20.8	8-Sep-20	0.0	8-Oct-20	0.0
9-Jun-20	19.4	9-Jul-20	80.4	9-Aug-20	8.8	9-Sep-20	0.0	9-Oct-20	6.0
10-Jun-20	8.0	10-Jul-20	65.0	10-Aug-20	10.6	10-Sep-20	0.0	10-Oct-20	0.0
11-Jun-20	18.2	11-Jul-20	60.6	11-Aug-20	72.4	11-Sep-20	0.0	11-Oct-20	5.0
12-Jun-20	13.0	12-Jul-20	15.2	12-Aug-20	66.2	12-Sep-20	29.0	12-Oct-20	1.0
13-Jun-20	45.8	13-Jul-20	9.8	13-Aug-20	43.0	13-Sep-20	17.0	13-Oct-20	9.0
14-Jun-20	15.2	14-Jul-20	76.8	14-Aug-20	64.4	14-Sep-20	16.6	14-Oct-20	5.0
15-Jun-20	20.0	15-Jul-20	118.0	15-Aug-20	64.6	15-Sep-20	14.8	15-Oct-20	101.0
16-Jun-20	18.8	16-Jul-20	129.4	16-Aug-20	73.4	16-Sep-20	12.2	16-Oct-20	4.0
17-Jun-20	31.6	17-Jul-20	53.0	17-Aug-20	57.8	17-Sep-20	25.4	17-Oct-20	0.0
18-Jun-20	129.6	18-Jul-20	36.8	18-Aug-20	61.4	18-Sep-20	13.2	18-Oct-20	0.0
19-Jun-20	96.8	19-Jul-20	18.8	19-Aug-20	47.8	19-Sep-20	7.6	19-Oct-20	0.0
20-Jun-20	5.6	20-Jul-20	25.6	20-Aug-20	20.2	20-Sep-20	9.0	20-Oct-20	0.0
21-Jun-20	2.2	21-Jul-20	0.6	21-Aug-20	103.8	21-Sep-20	6.4	21-Oct-20	1.0
22-Jun-20	16.8	22-Jul-20	5.2	22-Aug-20	22.4	22-Sep-20	50.4	22-Oct-20	1.0
23-Jun-20	9.3	23-Jul-20	0.0	23-Aug-20	10.4	23-Sep-20	22.0	23-Oct-20	0.0
24-Jun-20	2.2	24-Jul-20	0.0	24-Aug-20	6.6	24-Sep-20	33.2	24-Oct-20	0.0
25-Jun-20	0.0	25-Jul-20	23.8	25-Aug-20	10.4	25-Sep-20	5.0	25-Oct-20	1.0
26-Jun-20	1.0	26-Jul-20	2.0	26-Aug-20	12.0	26-Sep-20	10.6	26-Oct-20	6.0
27-Jun-20	0.0	27-Jul-20	8.0	27-Aug-20	3.6	27-Sep-20	49.2	27-Oct-20	0.0
28-Jun-20	13.4	28-Jul-20	125.6	28-Aug-20	19.0	28-Sep-20	0.0	28-Oct-20	0.0
29-Jun-20	6.2	29-Jul-20	0.6	29-Aug-20	38.4	29-Sep-20	0.0	29-Oct-20	0.0
30-Jun-20	6.6	30-Jul-20	32.4	30-Aug-20	46.4	30-Sep-20	0.0	30-Oct-20	0.0
		31-Jul-20	5.2	31-Aug-20	10.4			31-Oct-20	0.0

APPENDIX V

Design of Check Dam

Simple Kresnik formula,

$$Q = 25 A^{1/2}$$

Where, Q = maximum discharge of the stream (m^3/sec)

A = area of catchment (km^2) = 2 km^2

$$Q = 25 (2)^{1/2}$$

$$Q = 35.35 \text{ m}^3/\text{sec}$$

Discharge capacity is given by the following formulae,

$$Q = 1.75 LH^{3/2}$$

Where Q = runoff (m^3/sec)

L = length of crest (m)

H = depth of flow (m)

Assume, L = 15 m

$$35.35 = 1.75 \times (15) \times (H)^{3/2}$$

$$1.34 = H^{3/2}$$

$$H = 1.21 \text{ m}$$

Providing a freeboard, f = 0.3 m

Height of wing wall above crest, d = H + f

$$d = H + f$$

$$= 1.21 + 0.3$$

$$= 1.51 \text{ m}$$

Length of apron = $0.75 \times (\text{Fall} + \text{Height of wing wall above crest}) + \text{fall}$

$$= 0.75 \times (h + d) + h$$

(The proposed height of dam is 1.51 m, \square h = 1.51 m)

$$= 0.75 \times (1.51 + 1.51) + 1.51$$

\square Length of apron = 3.775 m

The design dimensions of check dam are as follows:

Maximum discharge of the stream, Q = $35.35 \text{ m}^3/\text{sec}$

Depth of flow, $H = 1.21$ m

Length of crest, $L = 15$ m

Height of wing wall above crest, $d = 1.51$ m

Length of apron = 3.775 m

APPENDIX VI

Design of Percolation Tank

Assume, Irrigation area = 10 ha

Depth of irrigation = 5 ha-cm

No. of Irrigation = 5

Catchment area = 100 ha

Agriculture area = 65 ha

Forest area = 35 ha

W.K.T., Precipitation (P) = 3000 mm

Soil type = clay loam

1) Volume of runoff (R)

$$R = \frac{CPA}{1000}$$

Where C = runoff coefficient

P = Precipitation (mm)

A = Catchment area (ha)

$$\begin{aligned} C &= \frac{C_1A_1 + C_2A_2}{A_1 + A_2} \\ &= \frac{0.4 \times 65 + 0.5 \times 35}{65 + 35} \\ &= 0.435 \end{aligned}$$

$$\begin{aligned} R &= \frac{0.435 \times 3000 \times 100}{1000} \\ &= 130.5 \text{ ha-m} \\ &= 13,05,000 \text{ m}^3 \end{aligned}$$

Pond will be designed for 1/3rd of volume of runoff

$$\begin{aligned} &= \frac{13,05,000}{3} \\ &= 4,35,000 \text{ m}^3 \end{aligned}$$

2) Water requirement = depth × irrigated area × number of irrigations

$$\begin{aligned} &= 5 \times 10 \times 5 \\ &= 250 \text{ ha-cm} \\ &= 250 \times \frac{10000}{100} \\ &= 25,000 \text{ m}^3 \end{aligned}$$

Assume the 20% of storage (seepage and evaporation) losses = 25,000 × 0.2

$$= 5000 \text{ m}^3$$

$$\begin{aligned}\text{Assume the 10\% allowance for siltation} &= 25,000 \times 0.1 \\ &= 2500 \text{ m}^3\end{aligned}$$

$$\begin{aligned}\text{Total tank capacity} &= 25,000 + 5000 + 2500 \\ &= 32,500 \text{ m}^3\end{aligned}$$

Design dimension for percolation tank area as follows:

Assume, depth of tank = 3 m

Let, A_0 = Bottom surface area

A_1 = Mid-section area

A_2 = Top surface area

Side slope = 2:1

Assume, bottom length (L_0) = 32 m

Bottom width (W_0) = 18 m

$$\begin{aligned}A_0 &= L_0 \times W_0 \\ &= 32 \times 18 \\ &= 578 \text{ m}^2\end{aligned}$$

$$A_1 = L_1 \times W_1$$

$$\begin{aligned}L_1 &= L_0 + \left(\frac{d}{2} \times s\right) 2 \\ &= 32 + (1.5 \times 2) 2 \\ &= 38 \text{ m}\end{aligned}$$

$$\begin{aligned}W_1 &= W_0 + \left(\frac{d}{2} \times s\right) 2 \\ &= 18 + (1.5 \times 2) 2 \\ &= 24 \text{ m}\end{aligned}$$

$$\begin{aligned}A_1 &= L_1 \times W_1 \\ &= 38 \times 24 \\ &= 912 \text{ m}^2\end{aligned}$$

$$A_2 = L_2 \times W_2$$

$$\begin{aligned}L_2 &= L_0 + (d \times s) 2 \\ &= 32 + (3 \times 2) 2 \\ &= 44 \text{ m}\end{aligned}$$

$$\begin{aligned}W_2 &= W_0 + (d \times s) 2 \\ &= 18 + (3 \times 2) 2 \\ &= 30 \text{ m}\end{aligned}$$

$$A_2 = 44 \times 30$$

$$= 1320 \text{ m}^2$$

$$\begin{aligned}\text{Volume of tank, } V &= \frac{d}{6} (A_0 + 4A_1 + A_2) \\ &= \frac{3}{6} (576 + 4(912) + 1320) \\ &= 2772 \text{ m}^3\end{aligned}$$

Note: 156 percolation tanks of size $38 \times 24 \times 3$ m are required.

□ The design dimensions are:

Depth of pond = 3 m

Side slope = 2:1

Top length (L_0) = 44 m

Top width (W_0) = 30 m

Top area (A_0) = 1320 m^2

Mid length (L_1) = 38 m

Mid width (W_1) = 24 m

Mid area (A_1) = 912 m^2

Bottom length (L_2) = 32 m

Bottom width (W_2) = 18 m

Bottom area (A_2) = 576 m^2

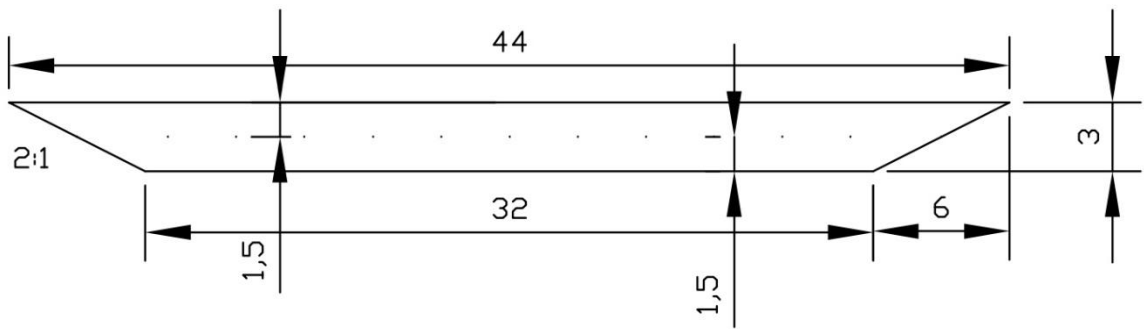

All dimensions are in meters
Figure: Length of percolation tank

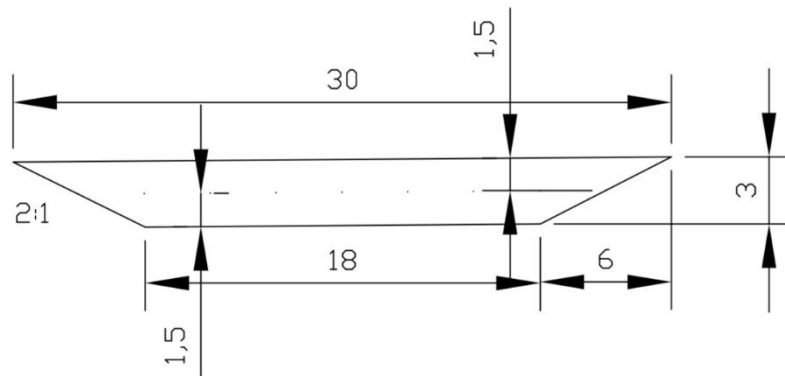

All dimensions are in meters
Figure: Width of percolation tank

APPENDIX VII

Design of Farm Pond

Estimation of volume of farm pond:

$$\text{Volume of pond (V)} = \frac{A + 4B + C}{6} \times D$$

Assume, water requirement = 3000 m³

Average depth of pond = 3 m

Bottom width = 30 m

Side slope = 1:5:1

Top length = 30 + (1.5 × 3) 2

$$= 39 \text{ m} \quad \square \quad 40 \text{ m}$$

Top width = 10 + (1.5 × 3) 2

$$= 19 \text{ m}$$

Top surface area, A = 39 × 19

$$= 741 \text{ m}^2$$

Mid length = 30 + (1.5 × 1.5) 2

$$= 14.5 \text{ m}$$

Mid-section area, 4 × B = 4 × (34.5 × 14.5)

$$= 2001 \text{ m}^2$$

Bottom surface, C = 10 × 30 = 300 m²

$$\begin{aligned} V &= \frac{A + 4B + C}{6} \\ &= \frac{741 + 2001 + 300}{6} \times 3 \\ &= 1521 \text{ m}^3 \\ &= 0.1521 \text{ ha-m} \end{aligned}$$

Note: - Two farm ponds of size 40 × 20 × 3 m are required

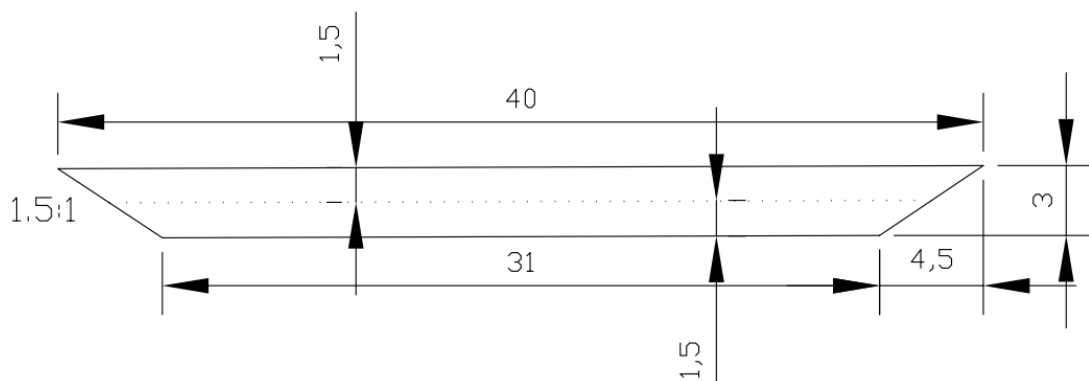

All dimensions are in meters

Figure: Length of Farm Pond

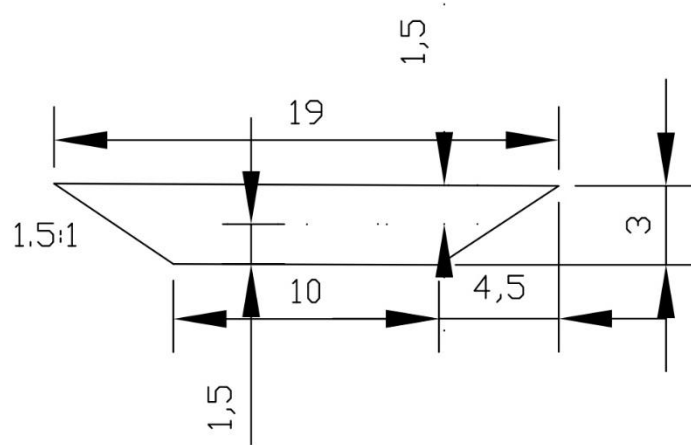

All dimensions are in meters

Figure: Width of Farm Pond

APPENDIX VIII

Values of Runoff coefficient (C)

S. No	Land use and topography	Sandy loam	Soil type clay and silt loam	Tight clay
1.	Cultivated land (a)Flat (b)Rolling (c)Hilling	0.30 0.40 0.52	0.50 0.60 0.72	0.60 0.70 0.82
2.	Pasture land (a)Flat (b)Rolling (c)Hilling	0.10 0.16 0.22	0.30 0.36 0.42	0.40 0.55 0.60
3.	Forest land (a)Flat (b)Rolling (c)Hilling	0.10 0.25 0.30	0.30 0.35 0.50	0.40 0.60 0.60
4.	Populated area (a)Flat (b)Rolling	0.40 0.50	0.55 0.65	0.65 0.80

APPENDIX IX Calculation of water budget

1) Rainfall (R) = 4145.4 mm

2) Hargreaves equation for Evapo-transpiration

$$(ET) = 0.0023 \times R_a \times (T_{\max} - T_{\min})^{0.5} \times (T_{\max} + 17.5)$$

- Highest rainfall record on July 4th, 2020 i.e., 156.4 mm
- So calculated T_{\max} , T_{\min} , T_{mean} , E_{pan} for July 2020

T_{\max} is on July 22nd, 2020 = 30.5°C

T_{\min} is on July 16th, 2020 = 22.1°C

$$\begin{aligned} T_{\text{mean of July}} &= \frac{T_{\max} + T_{\min}}{2} \\ &= \frac{30.5 + 22.1}{2} \\ &= 26.3^\circ\text{C} \end{aligned}$$

Extra-terrestrial Radiation (R_a):

For July month at latitude 17.7° (N 18°), R_a is 16.1 (Reference: - Table No. D4, Page 73, Irrigation Theory and Practices, A.M. Michael,)

$$R_a = 16.1 \times 2.45$$

$$= 39.445 \text{ MJ/m}^2/\text{day}$$

$$\begin{aligned} \square ET &= 0.0023 \times 39.445 \times (30.5 - 22.1)^{0.5} \times (26.3 + 17.8) \\ &= 11.59 \text{ mm/day} \end{aligned}$$

3) Pan Evaporation (E_{pan}) = 1.7 mm/day

(Average of E_{pan} of July, 2020)

4) Surface runoff (R_s) = 329.38 mm

[Taken from runoff map (ArcSWAT)]

5) Sub-surface recharge / Ground water recharge (G_s)

Krishna Rao formula, (1970)

For areas having rainfall > 2000 mm

$$R_r = K \times (P - X)$$

$$R_r = 0.35 \times (P - 600)$$

Where P= precipitation, mm

$$R_r = 0.35 \times (4145.4 - 600)$$

$$= 1240.89 \text{ mm}$$

Water Budget/Balance Equation

$$R = ET + E_{\text{pan}} + R_s + G_s + \Delta S$$

$$4145.1 = 11.59 + 1.7 + 329.38 + 1240.89 + \Delta S$$

$$4145.1 = 1583.46 + \Delta S$$

$$\Delta S = 2561.94 \text{ mm}$$