

Ethylene receptors and molecular mechanism of ethylene sensitivity in plants

Ajay Arora

Division of Plant Physiology, Indian Agricultural Research Institute, New Delhi 110 012, India

A short post-harvest longevity remains a major limiting factor for many crops. Separation from plant leads quickly to ripening of fruits and senescence of flowers. In many species, ripening and senescence are ethylene-regulated. Thus, attempts have been made to retard the post-harvest processes by applying chemicals that inhibit ethylene synthesis. The long-term solution will probably be based on genetically modified plants with genes that either suppress synthesis or reduce sensitivity to ethylene. Several genes that confer ethylene insensitivity are known, e.g. tomato *Nr* and dominant mutants of *Arabidopsis* ethylene receptor sensor genes, *ETR* and *ERS*. Transformation with the *etr1-1* allele delays fruit ripening, flower senescence and flower abscission of tomato and petunia. After the successful isolation of the *Arabidopsis* ethylene receptor gene *ETR1*, many *ETR1*-like genes has been isolated, based on sequence similarity and structural features, from various plant species. Characterization of ethylene receptor genes provides clues to understand how plants regulate their ethylene sensitivity. Therefore, an alteration of ethylene action is a valuable target for the genetic engineering of crops. Manipulation of ethylene biosynthesis or perception allows us to modulate these processes and thereby create plants with more robust and desirable traits, giving us a glimpse into the role of ethylene in the plant. The recent progress in genetic and protein analysis of ethylene receptors is summarized in this review. The possible strategies for altering the ethylene sensitivity of plants using ethylene receptor genes are also discussed.

Keywords: *Arabidopsis*, ethylene receptors, ethylene sensitivity, ripening, senescence.

THE plant hormone ethylene is involved in many aspects of the plant life cycle, including seed germination, root hair development, root nodulation, flower senescence, abscission, and fruit ripening¹. Despite its simple two-carbon structure, olefin ethylene is a potent modulator of plant growth and development². The production of ethylene is tightly regulated by internal signals during development and in response to environmental stimuli from biotic and abiotic stresses, such as wounding, hypoxia, ozone, chilling or freezing. To understand the roles of ethylene in plant functions, it is

important to know how this gaseous hormone is synthesized, how its production is regulated, and how the signal is transduced. The pathway of ethylene biosynthesis has been elucidated during the last few decades, and the basis for subsequent biochemical and molecular genetic analysis of this pathway has been provided³⁻⁵. Morphological changes in dark-grown (etiolated) seedlings treated with ethylene or its metabolic precursor, 1-aminocyclopropane-1-carboxylic acid (ACC), have been termed the 'triple response'. The exaggerated curvature of the apical hook, radial swelling of the hypocotyl, and shortening of the hypocotyl and root are unmistakable hallmarks of this ethylene response. Over the past decade, the triple response phenotype has been used to screen for mutants that are defective in ethylene responses^{6,7}. Etiolated *Arabidopsis* seedlings with minor or no phenotypic response upon ethylene application are termed ethylene-insensitive (*ein*) or ethylene-resistant (*etr*) mutants. Mutants have also been identified that display a constitutive triple response in the absence of ethylene^{8,9}. This class can be divided into subgroups based on whether or not the constitutive triple response can be suppressed by inhibitors of ethylene perception and biosynthesis, such as silver thiosulphate and aminoethoxyvinyl glycine (AVG). Mutants that are unaffected by these inhibitors are termed constitutive triple-response (*ctr*) mutants, whereas those whose phenotype reverts to normal morphology are termed ethylene-over-producer (*eto*) mutants, which are defective in the regulation of hormone biosynthesis. The genetic hierarchy among ethylene biosynthesis and signalling pathway components in *Arabidopsis* has been established by epistasis analysis using these mutants^{10,11}.

Recent progress in understanding the mechanism underlying the ethylene perception and signal transduction pathway has stimulated the production of transgenic plants with altered ethylene sensitivity¹². Transgenic plants can be powerful tools for elucidating the regulatory role of ethylene in plant development and stress responses as well as those with altered ethylene biosynthesis. In addition, transgenic plants that confer reduced sensitivity and insensitivity to ethylene are expected to have extended post-harvest life for commercial use.

In this review, current progress in the analysis of ethylene receptor genes and their function, including our results is summarized, and the potential strategies to regulate ethylene sensitivity of plants using ethylene receptor genes are discussed.

e-mail: romiarora@yahoo.com

Ethylene receptor genes: Isolation and characterization

Plant responses to hormones depend on the transmission of signals generated by the interaction of hormone ligands with their cognate receptors. This interaction is the first step in a complex series of reactions that results in the transduction and amplification of intracellular signals that alter gene expression and/or protein function. Ethylene perception in plant tissue requires specific receptors and a signal transduction pathway to coordinate downstream responses. Progress made in understanding the ethylene perception and signal transduction pathway has mainly been achieved by molecular studies that used the model plant *Arabidopsis*. Screening for alteration in the so-called triple response has identified ethylene response mutants, referring to morphological changes of dark grown seedlings in response to ethylene. Ethylene-insensitive mutants like *ETR1-1* do not exhibit a triple response⁶. The *ETR1* gene was isolated using map-based cloning technology and shown to encode structural motifs reminiscent of the two-component environmental sensors. Environmental sensors are protein communication modules in bacteria that contain two structural motifs – transmitters and receivers – that can be arrayed in complex combinations. In the simplest format, a sensor device monitors an environmental variable that activates a histidine kinase (the transmitter). Five domains that characterize the sensor – histidine kinase, including the acceptor histidine, are conserved in the N-terminal portion of *ETR1*. The second motif in the communication module, called a response regulator, is generally an independent polypeptide and functions to receive the sensor signal. This culminates in phosphoryl transfer from the phosphorylated histidine kinase to an Asp residue in the response regulator. The activated receiver then modulates the activity of unique C-terminal output domain, commonly a transcriptional regulator. The sensor element can be of the simple type or the hybrid-type, in which the sensor–transmitter kinase domain has an attached regulator domain. Whether simple or hybrid, an additional independent regulator domain exists, hence the descriptive term ‘two-component system’. The gene *ETR1* encodes a protein with amino acids similar to bacterial two-component sensor response–regulator systems and acts early in the response pathway as an ethylene receptor^{2,13}. Investigations of various ethylene-response mutants have led to the isolation of several genes that encode proteins involved in ethylene perception (*ETR1*; *ETR2* and *ERS* from *Arabidopsis*^{13–15}; and *NR* from tomato¹⁶). The deduced structures of the ethylene receptors include three or four putative transmembrane domains at the amino-terminus. Schaller and Bleeker¹⁷ demonstrated that the amino-terminal portion of *ETR1* could bind ethylene. Ethylene receptors function as dimers in the cell membrane¹⁸, and copper, a transition metal, is necessary as a cofactor for the binding of ethylene¹⁹. The amino acid sequences of the isolated mutant forms of *ETR1*, *ETR2* and *NR* each include a single amino acid substitution in the

hydrophobic amino-terminal domain, which results in an ethylene-insensitive phenotype^{13,14,16}. The amino acid sequence of *ETR1* includes a putative histidine kinase domain in which all of the residues required for histidine kinase activity are conserved¹³. Studies of ethylene perception in *Arabidopsis* have demonstrated that the mode of action of the receptors is essentially inhibitory: the receptors actively repress ethylene responses in the absence of ethylene and they become inactive upon binding ethylene²⁰.

Five members of the putative ethylene receptor gene family in *Arabidopsis* have been cloned. The five genes appear to belong to two subfamilies. Subfamily 1 consists of *ETR1* and *ERS1*, whereas subfamily 2 contains *ETR2*, *EIN4* and *ERS2*. Members of the same subfamily have higher amino acid sequence homology with each other than with members in the other subfamily. Additionally, genes in the same family have conserved intron positions that are not shared between the two subfamilies (Figure 1). This division of subfamilies is not related to the presence or absence of the receiver domain (*ERS1* and *ERS2* belong to different subfamilies^{15,21}; Figure 1). A similar family of two-component ethylene receptors has also been characterized in tomato, where five putative receptor genes have been cloned^{22–26}, termed *LeETR1–LeETR5*. One of these homologues (*LeETR3*) was identified as the gene associated with the never-ripe (*NR*) phenotype¹⁶. Predicted protein sequences of *LeETR1* and *LeETR2* are highly homologous to *Arabidopsis ETR1*, while *NR* exhibits similarity to *Arabidopsis ERS1*, also missing the response regulator domain^{25,27}. *LeETR4* and *LeETR5* are most closely related^{26,27} to *Arabidopsis ETR2* and *EIN4*. *ETR1* homologues have also been

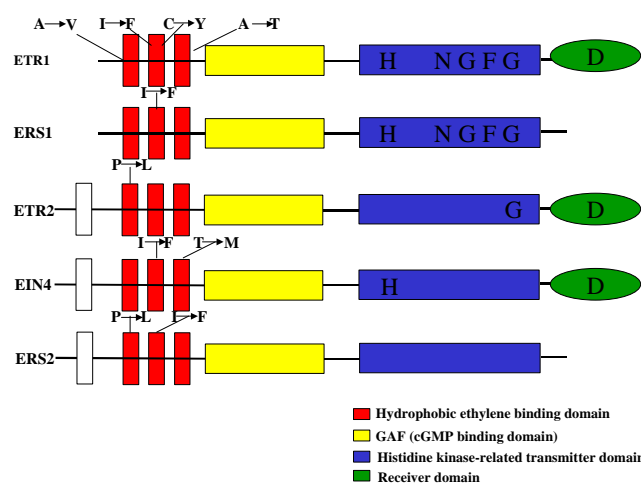

Figure 1. Structural characteristics of members of the *ETR1* family of ethylene receptors from *Arabidopsis*. For all members of the family, homology extends from the ethylene-binding domain through the histidine kinase-related transmitter domain. Where present, conserved sub-domain characteristics of functional histidine kinases are indicated by the letters H, N, G, F, and G. Based on sequence similarities and defining structural characteristics, the family can be divided into the *ETR1* and *ETR2* subfamily. Amino acid substitutions that individually confer dominant insensitivity throughout the plant are indicated.

isolated from other plants: the *RP-ERS1* cDNA from *Rumex palustris*²⁸, *Cm-ETR1* and *Cm-ERS1* cDNAs from *Cucumis melo*^{29,30}, *PE-ETR1* and *PE-ERS1* cDNAs from *Passiflora edulis*³¹, *PhETR1* and *PhETR2* from *Pelargonium X hortorum*³², *NTHK1* from tobacco³³, *PpETR1* from *Prunus persica*³⁴, *NT-ERS1* from tobacco³⁵, and *PcETR1* and *PcERS1* from *Pyrus communis*³⁶. Recently, a cDNA from deep-water rice treated with ethylene encoding ethylene receptor homologues to *Arabidopsis thaliana* *ETR2* and *EIN4* was isolated³⁷.

Most information on the biology of fruit ripening and flower senescence has been obtained from the study of fruits and flowers, where the gaseous plant hormone ethylene coordinates the entire perception process. *Gladiolus* is a popular type of cut-flower, but the ornamental longevity is short. Exogenous ethylene and ethylene inhibitors have no effect on petal senescence of gladiolus³⁸. We, as well as others have observed such ethylene insensitivity in most cultivars of gladiolus³⁹. By Western blot analysis we could detect both the ethylene receptors, viz. GgERS1a and GgERS1b proteins as expected, with size of 70.6 and 34.9 kDa, respectively. The expression studies (mRNA and protein) clearly show that both the genes are expressing well. The expression of both genes suggests they are important in the subfunctionalization process for providing ethylene insensitivity to gladiolus flowers⁴⁰⁻⁴².

Most of the work related to ethylene perception or signaling processes has mainly focused on dicotyledonous plants. However, little is known about the involvement of receptor genes in the ethylene perception of monocotyledonous plants such as rice. Rice is an important cereal crop and also a major food source for more than one-third of the world's population. The molecular cloning of a genomic sequence of a putative ethylene receptor gene designated as *OS-ERS1* from rice⁴³. In addition, the isolation of four other ethylene receptor gene homologues designated as *OS-ERS2*, *OS-ETR2*, *OS-ETR3* and *OS-ETR4* is described. The differential expression patterns of *OS-ERS1*, *OS-ERS2* and *OS-ETR2* in different tissues of rice have also been compared together with their response to exogenous auxin and the ethylene action inhibitor, silver ion.

A phylogenetic tree, constructed from various ethylene receptors, indicates that similar to *Arabidopsis* sequences, the five ethylene receptor proteins in rice can be divided into two subfamilies. One subfamily consists of *OS-ERS1* and *OS-ERS2* (only *ERS*-type homologues are present) in which they do not have the receiver domain, whereas the second group contains *OS-ETR2*, *OS-ETR3*, and *OS-ETR4*. *OS-ETR2*, *OS-ETR3* and *OS-ETR4* are more structurally divergent from each other, and *OS-ETR3* and *OS-ETR4* contain only three *N*-terminal hydrophobic regions. The putative histidine kinase domains in these three members are different from the canonical bacterial histidine kinase sequences. Notably, the autophosphorylated histidine residue is absent in both *OS-ETR2* and *OS-ETR3*, suggesting that they may not be active histidine kinases.

Analysis of the expression of the three-ethylene receptor genes in rice has demonstrated their tissue or developmental stage specificity. Both in *Arabidopsis* and tomato, the expression patterns alter among different ethylene receptor homologues. For instance, *At-ERS1* was ubiquitously expressed in *Arabidopsis*, whereas stronger expression of *At-EIN4* was observed in pollen and tapetum cells compared with the *At-EIN4* mRNA level in leaves and roots. Furthermore, in tomato, *Le-ETR1* was expressed constitutively in all the tissues examined, whereas *Le-ETR2* was expressed at a low level in vegetative tissues but up-regulated in seeds before germination. In rice, the three ethylene receptor genes (*OS-ERS1*, *OS-ERS2* and *OS-ETR2*) also behave similarly in that their corresponding mRNA levels vary in different tissues. *OS-ERS1* was constitutively expressed in all the tissues studied, whereas *OS-ETR2* was expressed at lower levels in green vegetative tissues than in young etiolated seedlings. By contrast, the transcript levels of *OS-ERS2* (when compared with that of *OS-ERS1* and *OS-ETR2*) are low, but still detectable, and present at a higher amount in green vegetative tissues than in etiolated seedlings. Notably, the expression levels of these three mRNAs are strongest in reproductive tissues such as anthers, when compared with their corresponding abundance in other tissues. It is also worth noting that only anthers isolated from two different developmental stages (meiotic and microspore stage) of pollen were used in the study. Therefore, active involvement of the ethylene receptor gene family during early pollen development implies that ethylene may play an important role in regulating the initial formation stages of anther.

Recently, it has also been demonstrated that flooding could also stimulate the accumulation of *OS-ETR2* mRNA in rice seedlings⁴³. Similar to these findings, an exogenous stimulus such as IAA or ethylene could also up-regulate the expression levels of both *OS-ETR2* and *OS-ERS1* (although to a much lesser extent) in etiolated rice seedlings. However, the response of *OS-ETR2* to either ethylene or IAA is more sensitive than that of *OS-ERS1*. It has been reported that auxin could stimulate ethylene production in various plant tissues by promoting *de novo* synthesis of ACC synthase⁴⁴. It was proposed that the effect of IAA on the positive regulation of both *OS-ERS1* and *OS-ETR2* mRNA levels is mediated through an ethylene-dependent pathway. The evidence that this up-regulation process could be completely blocked by pretreatment with silver ions, further supports this hypothesis. The *OS-ERS2* transcript level was shown to be down-regulated by both IAA and ethylene, since its level decreased inversely with increase in ethylene production applied or produced. This result indicates that *OS-ERS2* is not positively regulated by ethylene. More ethylene receptors can actually desensitize the tissue to ethylene, while fewer ethylene receptors increase its sensitivity. Therefore, it is possible that reduction of *OS-ERS2* transcript levels can ultimately increase the ethylene sensitivity of rice in response to IAA- or ethylene-treated etiolated rice seedlings. Consider-

ing the up-regulation of *OS-ETR2* mRNA levels by ethylene and the down-regulatory effect of ethylene on *OS-ERS2* expression would seem paradoxical. Further studies are needed to establish the correlation between ethylene receptor levels and sensitivity to ethylene as well as their individual threshold levels, to initiate ethylene responses.

EIN2 is a central signal transducer in the ethylene-signalling pathway, and a unique membrane-anchored protein. By screening a cDNA library, a cDNA clone has been isolated (*OsEIN2*)⁴⁵ that encodes the rice *EIN2* homologue. *OsEIN2* shares significant amino acid sequence similarity with *Arabidopsis* *EIN2* (57% similarity and 42% identity). Both the number and position of introns and exons in the *OsEIN2* and *AtEIN2* coding regions are also conserved. To address whether this structural similarity is indicative of functional conservation of the corresponding proteins, transgenic lines expressing the antisense construct of *OsEIN2* were also generated. Transgenic plants were stunted and shoot elongation was severely inhibited. Their phenotypes were similar to those found with wild-type rice seedlings that were treated with AgNO₃, an ethylene signal inhibitor. In *OsEIN2* antisense plants, expression levels of two ethylene-responsive genes, *SC129* and *SC255*, were decreased compared with the wild types. These results suggest that *OsEIN2* is a positive component of the ethylene-signalling pathway in rice, just as *AtEIN2* is in *Arabidopsis*. Their antisense transgenic plants produced approximately 3.5 times more ethylene than wild-type plants. Expression analysis of rice *ACS* and *ACO* genes showed that the transcript levels of *OsACS1* and *OsACO1* were elevated in transgenic plants⁴⁵.

Ethylene is perceived by a system typically consisting of two proteins: a histidine kinase as the sensor that autophosphorylates an internal histidine residue in response to environmental signals, and a response regulator that activates the downstream components upon receiving a phosphate from the histidine residue of the sensor on its aspartate residue^{46,47}. Since homodimerization of *ETR1* and *ERS1* has been observed in plants^{18,48}, receptors that do not have the receiver domains, *ERS1* and *ERS2*, have been postulated to use the receiver domains of other proteins by forming heterodimers with them²¹. The fact that members of a family of photoreceptors, the phytochromes, have a histidine kinase domain related to two-component systems but exhibit serine/threonine kinase activity⁴⁹, supports the notion that the *ETR2* class of receptors may function not as histidine kinases but possibly as serine/threonine kinases. Several models have been proposed for receptor function ethylene signal transduction. The receptors could be modulating *CTR1* kinase activity directly by a change in their conformation in response to ethylene binding, or phosphorylation of the receptors could be responsible for receptor and *CTR1* turnover after ethylene binding. It cannot be ruled out that the receptors might be sequestering a downstream component of the signalling pathway that is released upon ethylene binding and/or protein phosphorylation. In this scenario,

phosphorylation could lead to receptor turnover or a change in its conformation, either of which would lead to release of the sequestered component. To answer these questions it will be necessary to know if serine phosphorylation occurs *in vivo* and whether serine phosphorylation is required to maintain the repressed state or to release this repression. The biochemical data presented by Moussatche and Klee⁵⁰ provide support for genetic evidence that histidine autophosphorylation is not necessary for maintaining the repression of ethylene signalling and suggest that receptor signalling does not occur through a phosphorelay. However, as autophosphorylation has been retained despite sequence divergence of the ethylene receptor family, it seems likely that this activity is important for receptor function.

Genetic and biochemical analyses of the ethylene receptors have lent insight into the mechanism of regulation in plants. *etr1*, *etr2*, and *ein4* were initially identified as dominant ethylene-insensitive plants^{6,14,21,51}. Similar missense mutations introduced into the *N*-terminal transmembrane domain of *ERS1* and *ERS2* cause the same ethylene insensitive phenotype, suggesting their role in ethylene perception¹⁵. Isolation of the loss-of-function alleles of *ETR1*, *ETR2*, *EIN4* and *ERS2* by screening for intragenic suppressors of the dominant receptor mutants provides genetic evidence of how the ethylene receptors actually work²⁰. The absence of phenotypes in single-receptor mutants suggests that in spite of the structural differences, there is functional redundancy (or compensation of function) among the receptors. The constitutive triple response observed in a quadruple-receptor mutant indicates that the receptors negatively regulate this ethylene response. Consistent with these elegant genetic studies is the observation that the dominant ethylene-insensitive mutant *etr1* binds less ethylene^{17,19}. The synthesis of the results from both genetic and biochemical studies leads one to conclude that ethylene receptors are inactivated by ethylene binding. Interestingly, members of both *ETR1* and *ETR2* subfamilies have also been identified in other plant species. In tomato, the *Never Ripe (NR)* gene encodes a receptor similar to the *ETR1* class with no receiver domain, whereas *LeETR4* is an *ETR2* class member with a receiver domain. Reduction in the expression level of *LeETR4* leads to enhance ethylene responses in tomato plants, and overexpression of *NR* can compensate for the loss of *LeETR4* and eliminates ethylene sensitivity. These results reveal that mechanisms of ethylene perception are likely conserved among flowering plants⁵². In the course of purifying the *ETR1* ethylene-binding activity, it was discovered that the addition of copper ions was required for the recovery of binding activity in yeast extracts. Subsequently, it was shown that copper copurifies in stoichiometric amounts with the ethylene-binding domain extracted from membranes of yeast overexpressing the *ETR1* binding domain¹⁹. Both ethylene-binding activity and copurification of copper were eliminated when the *etr1-1* mutation, a conversion of Cys65 to Tyr, was introduced into the protein. Among several transition metals tested, only silver ions mimicked

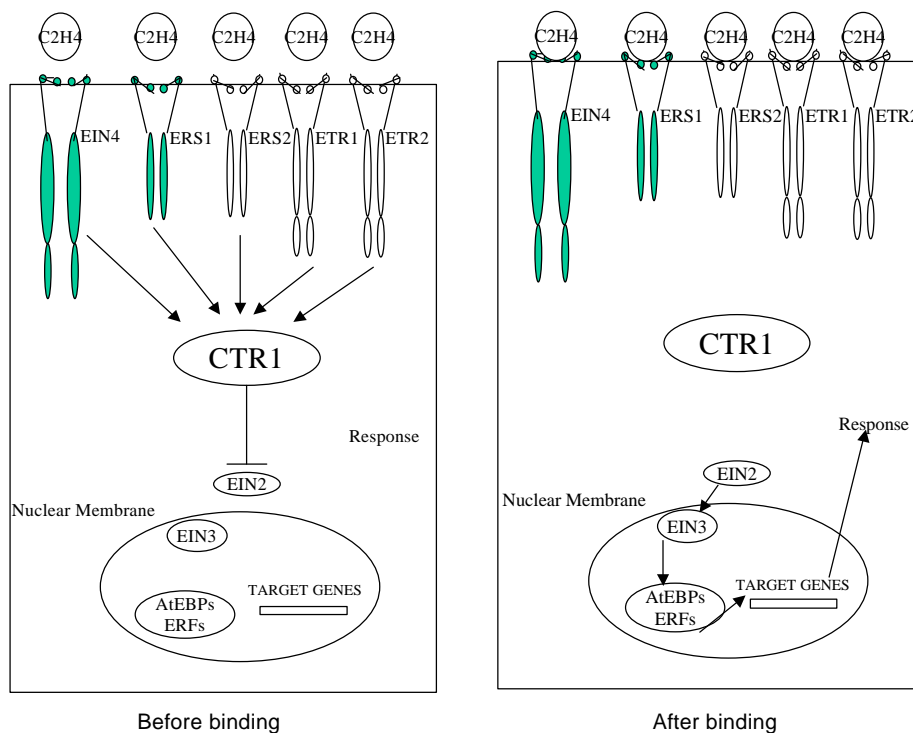

Figure 2. Schematic diagram of the pathway of ethylene signal transduction in *Arabidopsis*. In the receptor inhibition model, receptor isoforms signal to CTR1 in the absence of ethylene. Ethylene inhibits this signalling and CTR1 is inactivated. Then, EIN2, EIN3 and EILs are activated and ethylene responses occur. Mutants that have lost ethylene-binding ability would continue to activate CTR1 in the presence of ethylene and thus suppress response pathways downstream from CTR1.

the effect of copper. This is consistent with the close chemical similarities of these two ions, and also provides a possible explanation for the inhibitory effects of silver ions on ethylene responses *in vivo*. Silver appears to be capable of replacing copper and interacting with ethylene, but not in transducing the signal to downstream effectors. Further evidence for a role of copper in ethylene signalling comes from the characterization of the *Arabidopsis responsive-to-antagonist (RAN1)* gene⁵³. Two weak mutant alleles, *ran1-1* and *ran1-2*, were identified in a screen for mutants that displayed an ethylene-like triple response to treatment with the potent ethylene antagonist, transcyclooctene. More importantly, the mutant allele *ran1-3/ctr2* or co-suppression of the *RAN1* gene led to a constitutive ethylene response phenotype. This is consistent with a loss-of-receptor function^{52,54}. This phenotype can be partially rescued by exogenous copper application. Cloning and subsequent functional analysis of *RAN1* revealed that it encodes a copper transporter that shares similarity with copper-transporting *P*-type ATPases such as the yeast Ccc2p and human Menkes/Wilson disease proteins⁵². Taken together, these findings indicate that *RAN1* is involved in delivery of copper to the ethylene receptor and that this copper-delivery pathway is required to create functional ethylene receptors in plants.

Signalling

In a screen for *Arabidopsis* mutants that display the constitutive triple-response phenotype, only one complementation group, *ctr1*, proved to be unaffected by ethylene synthesis inhibitors or ethylene antagonists. Genetic epistatic analysis has placed CTR1 downstream of the ethylene receptors in the ethylene-signalling pathway (Figure 2). The recessive nature and constitutive phenotype of the *ctr1* mutant indicate that CTR1 is a negative regulator of downstream signalling events⁸. Cloning of the CTR1 gene revealed that it belongs to the Raf family of Ser/Thr protein kinases that initiate mitogen-activated protein (MAP)-kinase signalling cascades in mammals^{55,56}. The similarity of CTR1 to known MAPKKs implies that ethylene signalling may operate through a MAP-kinase cascade (Figure 3). Although many genes with homology to MAPKKs and MAPKs have been identified in the *Arabidopsis* genome sequence, to date none has been associated with ethylene signalling. Thus far, no intermediate components have been identified genetically or biochemically to act between the receptors and CTR1 kinase. In fact, yeast two-hybrid and *in vitro* bindings have shown that the kinase domain of ETR1 and ERS1 can directly interact⁵⁷ with CTR1. Because the response regulator domain

of ETR1 can also interact with several *Arabidopsis* histidine-containing phosphotransfer proteins⁵⁸, *in vivo* relevance of these *in vitro* interactions needs to be confirmed.

Identification of the MAPKs that respond to and mediate ethylene signalling is important. However, it is equally interesting to know whether the identified MAPK pathway functions independently or as part of the genetically defined ethylene-signalling cascade. For this purpose, mutants of all four identified components of the ethylene pathway, *ETR1*, *CTR1*, *EIN2* and *EIN3*, were analysed biochemically for their ethylene-inducible MPK6 MAPK activity profile in the absence of and after treatment with ACC⁵⁹. Dominant ethylene-insensitive *etr1-1* mutants showed no MPK6 activity in the absence or presence of ACC, indicating that *ETR1* is an upstream component of the MAPK pathway. In contrast, *ctr1* mutants revealed constitutive activation of the MPK6 kinase, demonstrating that *CTR1* functions as an upstream negative regulator of the MAPK pathway. These results support the concept that *ETR1* is an upstream regulator of *CTR1* and the MAPK pathway. In wild-type plants, *ETR1* becomes inactivated in response to ethylene. However, in the dominant insensitive *etr1-1* mutant, *etr1* cannot be inactivated by ethylene and therefore *CTR1* stays constitutively active, abrogating the ability of ethylene to activate the MAPK pathway.

Although consistent with the genetic model that *CTR1* functions as a negative regulator of ethylene signalling,

the result that a protein kinase loss-of-function *CTR1* mutant should result in activation of its downstream MAPKs is surprising. However, *EDR1*, encoding another *Arabidopsis* MAPKKK, was also identified as a negative regulator of pathogen defence responses⁶⁰. Moreover, complementation assays of *CTR1* in yeast and functional analyses of mammalian *Raf-1* raise the possibility that these MAPKKs might not be functioning in MAPKK activation, but in that of other targets^{61,62}. In this context, it is worth noting that in contrast to other MAPKKs, SIMKK shows high auto activity that is likely to be due to the unique feature of carrying a negatively charged amino acid in its phosphorylation loop⁶³. This feature could allow SIMKK regulation through direct physical interaction with *CTR1* or as yet unknown intermediate factor(s). In this scenario, ethylene-induced MAPK activation would be relayed through *CTR1*-mediated relief of SIMKK inhibition (Figure 3).

Biochemical analysis of the ethylene-insensitive *ein2* and *ein3* mutants showed no enhanced MPK6 activity in untreated plants, but normal activation upon ACC treatment. These data are consistent with the notion that the MAPK pathway functions either upstream or independently of *EIN2* and *EIN3*. Since SIMKK transgenic lines with constitutively active MPK6 show enhanced expression of ethylene-inducible marker genes, it is likely that *EIN2* and *EIN3* are downstream targets of the MAPK pathway.

Taken together, this work shows that a MAPK pathway is involved in ethylene signalling in *Medicago* and *Arabidopsis* plants. In accordance with previous genetic and biochemical analyses, the following model for ethylene signal transduction is proposed (Figure 3). *ETR1* acts upstream of the MAPK module, being composed of the MAPKKK *CTR1*, the MAPKK *SIMKK*, and the MAPKs *SIMK/MMK3* or *MPK6/13*. In agreement with the genetic model, data⁶³ indicate that *CTR1* acts as a negative regulator of the downstream MAPKs, which are upstream regulators of ethylene target genes. How the MAPKs activate ethylene target genes through *EIN2* and *EIN3* presently is unclear, but physical interaction and phosphorylation are obvious options that are under investigation.

Genetic epistasis analysis of ethylene response mutants has shown that *EIN2* acts downstream of *CTR1* and upstream of *EIN3*. Null mutations in *EIN2* result in the complete loss of ethylene responsiveness throughout plant development, suggesting that *EIN2* is an essential positive regulator in the ethylene-signalling pathway. *EIN2* encodes a novel integral membrane protein⁶⁴. The N-terminal hydrophobic domain of *EIN2* shows similarity to members of the NRAMP family, which includes metal-ion transporters such as the yeast *Smf1p*, *Drosophila* Malvolio, and mammalian *DCT1*. The C-terminal hydrophilic region has no homology to any known protein, although it does have motifs typically involved in protein-protein interactions. Overexpression of the C-terminal portion of the protein (*EIN2* CEND) in an *ein2* null background results in constitutive activation of some but not all ethylene responses and restores the ability of the mutant

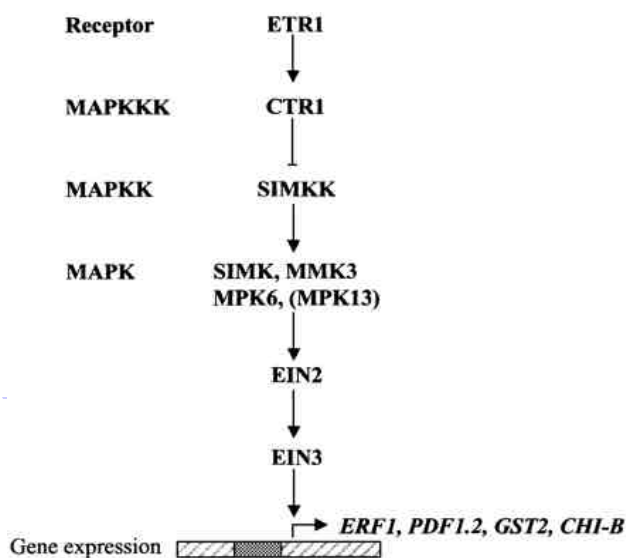

Figure 3. Proposed model of MAPK pathway mediating ethylene signalling in plants. The histidine kinase *ETR1* functions as an ethylene receptor and activates *CTR1* in the absence of ethylene. *CTR1* is a negative regulator of the MAPKK *SIMKK* and the MAPKs *SIMK/MMK3* in *Medicago*, and *MPK6/13* in *Arabidopsis*. In the presence of ethylene, *ETR1* and *CTR1* become inactivated, relieving *SIMKK* from inhibition. Subsequent activation of MAPKs activates gene expression of ethylene-responsive genes via direct activation of *EIN2* and *EIN3* or through other factors.

to respond to paraquat and jasmonic acid, but not ethylene. These results suggest that the N-terminal portion of EIN2 is necessary for sensing the ethylene signal from upstream components in the pathway, whereas EIN2 CEND is required for transducing the signal to the downstream components. Interestingly, *ein2* mutants have been independently isolated in several different genetic screens designed to identify components of other signalling pathways. For example, *ein2* mutants have been found in screens for defects in auxin transport inhibitor resistance⁶⁵, cytokinin response⁶⁶, ABA hypersensitivity^{67,68} and delayed senescence⁶⁹. In addition, *ein2* mutants also show altered sensitivity to several bacterial and fungal pathogens. At least in some cases, such as cytokinin resistance and delayed senescence, the abnormalities observed in *ein2* are simply the result of its ethylene insensitivity.

Five ethylene-insensitive loci (*wei1-wei5*) were identified⁷⁰ using a low-dose screen for 'weak' ethylene-insensitive mutants. *wei1*, *wei2* and *wei3* seedlings showed hormone insensitivity only in roots, whereas *wei4* and *wei5* displayed insensitivity in both roots and hypocotyls. The genes corresponding to *wei1*, *wei4* and *wei5* were isolated using a positional cloning approach. The *wei1* mutant harboured a recessive mutation in *TIR1*, which encodes a component of the SCF protein ubiquitin ligase involved in the auxin response. *wei4*, a dominant mutant, resulted from a mutation in the ethylene receptor *ERS*, whereas *wei5*, a semidominant mutant, was caused by a mutation in the *EIN3*-related transcription factor gene *EIL1*. The simultaneous loss of functional *WEI5/EIL1* and *EIN3* nearly completely abolished the ethylene response in etiolated seedlings, and adult plants were highly susceptible to infection by the necrotrophic fungal pathogen *Botrytis cinerea*. Moreover, *wei5/eil1 ein3* double mutants were able to fully suppress constitutive signalling caused by *ctr1*, suggesting a synergistic interaction among these gene products. Unlike previously known root ethylene-insensitive mutants, *wei2* and *wei3* were not affected in their response to auxin and showed a normal response to gravity. Genetic mapping studies indicate that *wei2* and *wei3* correspond to previously unidentified ethylene pathway genes that may control cell-elongation processes functioning at the intersection of the ethylene and auxin response pathways.

Nuclear events

Many ethylene responses involve changes in gene expression. The cloning of *EIN3* provided direct evidence for nuclear regulation in the early ethylene signal transduction pathway⁷¹. *EIN3* encodes a novel nuclear-localized protein that belongs to a multigene family in *Arabidopsis*. Among six members of this family, *EIN3*, *EIN3-like-1* (*EIL1*), and *EIL2*, can rescue the *ein3* mutant phenotypes. This indicates that not only *EIN3* but also *EIL1* and *EIL2* are involved in ethylene signal transduction, explaining

why null mutations in *ein3* cause only partial ethylene insensitivity. Overexpression of *EIN3* in an *ein2* null mutant background causes constitutive activation of the ethylene response, similar to overexpression of the EIN2 CEND, confirming that *EIN3* acts downstream of *EIN2*. *EIN3* gene expression is not induced by ethylene. This result indicates that EIN3 may be regulated by ethylene at the protein level. *EIN3*-like transcription factors have also been identified in other plant species. The tobacco *EIN3*-like gene, *TEIL*, has been cloned. Plants that overexpress the *TEIL* cDNA exhibit constitutive triple-response phenotypes⁷². Tomato orthologues of *EIN3*-like genes, *LeEIL1*, *LeEIL2* and *LeEIL3*, have also been cloned⁷³. Each complements the *ein3-1* mutation in transgenic *Arabidopsis*, indicating that all are likely involved in ethylene responses. Antisense tomato plants with reduced expression of a single *LeEIL* gene did not exhibit significant changes in ethylene response. However, reduced expression of multiple tomato *LeEIL* genes reduced significantly the sensitivity to ethylene, providing evidence of functional redundancy.

A search for target promoters for the EIN3 family of proteins led to the identification of the primary ethylene response element in the promoter of the *ERF1* gene⁷⁴. *In vitro* DNA-binding studies revealed that homodimers of either EIN3 or EIL1 proteins were able to bind primary ethylene response elements⁷⁴ in the promoters of *ERF1*. *ERF1* belongs to a large family of plant-specific transcription factors referred to as ethylene-response-element binding proteins (EREbps). EREbps were originally identified on the basis of their ability to bind to the GCC box, a DNA motif associated with ethylene- and pathogen-induced gene expression. *EIN3* is both necessary and sufficient to stimulate *ERF1* expression. Moreover, overexpression of *ERF1* in an *ein3* background leads to constitutive activation of a subset of ethylene phenotypes. These results indicate that *ERF1* may regulate one branch of the ethylene response pathway downstream of *EIN3*. Interestingly, although a large number of EREbps have been found in the *Arabidopsis* genome and other plant species⁷⁵, only a few have been shown to be regulated by ethylene⁷⁶. Salicylic acid, jasmonic acid, salt, drought and other stresses are among the growing number of stimuli known to regulate the expression of these genes⁷⁷⁻⁸³. Thus, in keeping with the more general role for the EREbps, the GCC box is likely to be a more general transcriptional regulatory element that is not specific to the ethylene response.

Ubiquitination of various intracellular proteins by ubiquitin-protein ligases (or E3s) plays an essential role in eukaryotic cell regulation, primarily through its ability to selectively target proteins for degradation by the 26S proteasome. Skp1, Cullin, F-box (SCF) complexes are an influential E3 class that use F-box proteins to deliver targets to a core ligase activity provided by the Skp1, Cullin, and Rbx1 subunits. Almost 700 F-box proteins can be found in *Arabidopsis*, indicating that SCF E3s likely play a

pervasive role in plant physiology and development. The reverse genetic analysis of two F-box proteins, EBF1 and EBF2 work coordinately in SCF complexes to repress ethylene action⁸⁴. Mutations in either gene cause hypersensitivity to exogenous ethylene and its precursor 1-aminocyclopropane-1-carboxylic acid. *EBF1* and *EBF2* interact directly with ethylene insensitive 3 (*EIN3*), a transcriptional regulator important for ethylene signalling. Levels of *EIN3* are increased in mutants affecting either *EBF1* or *EBF2*, suggesting that the corresponding SCF complexes work together in *EIN3* breakdown. Surprisingly, double *ebf1 ebf2* mutants display a substantial arrest of seedling growth and have elevated *EIN3* levels, even in the absence of exogenous ethylene. Collectively, their results show that the SCF^{*EBF1/EBF2*}-dependent ubiquitination and subsequent removal of *EIN3* is critical not only for proper ethylene signalling, but also for growth in plants⁸⁵.

The magnitude of the ethylene response directly correlates with the level of *EIN3*, indicating that this transcription factor sits at a key checkpoint in the response pathway⁷⁴. The action of *EIN3* is, in part, modulated by alterations in its half-life⁸⁶, whereas ethylene appears to promote *EIN3* stability; glucose, which antagonizes ethylene action, promotes its breakdown. This breakdown is dramatically retarded by the 26S proteasome-inhibitor MG132, suggesting that *EIN3* levels are controlled by the Ub/26S proteasome pathway⁸⁶. Taken together, it appears that various signals, including ethylene, converge to directly modulate *EIN3* turnover, possibly by inhibiting or promoting its ubiquitination by one or more E3s and/or subsequent turnover by the 26S proteasome.

The *EIN3* protein levels rapidly increase in response to ethylene and this response requires several ethylene-signalling pathway components, including the ethylene receptor⁸⁴ (*ETR1* and *EIN4*), *CTR1*, *EIN2*, *EIN5*, and *EIN6*. In the absence of ethylene, *EIN3* is quickly degraded through a ubiquitin/proteasome pathway mediated by two F box proteins, *EBF1* and *EBF2*. Plants containing mutations in either gene show enhanced ethylene response by stabilizing *EIN3*, whereas *ebf1 ebf2* double mutants show constitutive ethylene phenotypes. Plants overexpressing either F-box gene display ethylene insensitivity and destabilization of *EIN3* protein. These results reveal that a ubiquitin/proteasome pathway negatively regulates ethylene responses by targeting *EIN3* for degradation, and pinpoint *EIN3* regulation as the key step in response to ethylene. The results were also confirmed by identifying two *Arabidopsis* F-box proteins, *EBF1* and *EBF2*, that interact physically with *EIN3/EIL* transcription factors⁸⁷. *EBF1* overexpression results in plants insensitive to ethylene. In contrast, plants carrying the *ebf1* and *ebf2* mutations display a constitutive ethylene response and accumulate the *EIN3* protein in the absence of the hormone. Their work places *EBF1* and *EBF2* within the genetic framework of the ethylene-response pathway and supports a model in which ethylene action depends on *EIN3* protein stabilization.

New ethylene mutants

Several novel ethylene-related mutants have been identified. The *Arabidopsis* mutant *enhanced ethylene response* (*eer*) was identified by novel genetic screen using subthreshold levels of ethylene⁸⁸. The *eer1* mutant displays increased ethylene sensitivity in the hypocotyl and stem, but reduced sensitivity in root. Like the *eto* class of ethylene overproducer mutants, the *eer1* mutant phenotype is suppressed by treatment with the ethylene biosynthesis inhibitor AVG. Similarly, the *eer1* phenotype is completely suppressed by the ethylene-insensitive mutations *etr1-1* and *ein2-1*. However, *eer1* displays a highly exaggerated triple-response phenotype and shows an additive effect when combined with the constitutive ethylene response mutant *ctr1-3*, suggesting that the *eer1* phenotype is not simply the result of ethylene overproduction. *eer1* seedlings have significantly elevated levels of basic-chitinase expression, suggesting that *eer1* may be highly sensitive to low levels of endogenous ethylene. Interestingly, like *ran1* mutant, *eer1* shows ethylene-like responses to ethylene receptor antagonists. Although the specific step at which *EER1* acts has not been established, these results suggest that *EER1* may act in addition to *CTR1* to oppose ethylene responses in the hypocotyl and stem. It is possible that *EER1* can regulate ethylene receptor function or is involved in an alternate ethylene-signalling pathway that bypasses the requirement for functional *CTR1*. Cloning and characterization of *EER1* should help elucidate its role in ethylene response.

There is also new information about an old tomato ethylene-related mutant called *epinastic* (*epi*). Dark-grown *epi* seedlings display a phenotype similar to the triple response in the absence of ethylene⁸⁹. Double mutant analysis between *epi* and dominant ethylene-insensitive receptor mutant *NR* revealed that *epi* likely acts downstream of ethylene receptor *NR*. Interestingly, unlike *ctr1*, *epi* does not demonstrate a global constitutive ethylene response, suggesting a role for *EPI* either in the regulation of a subset of ethylene responses regulating the cell expansion or in an independent pathway required for normal growth. In addition, *epi* does not show linkage to either of the two previously reported tomato *CTR1* homologues⁹⁰, *LeCTR1* and *LeCTR2*. Cloning and characterization of the genes corresponding to these new mutants, *eer1* and *epi*, as well as the existing ethylene-insensitive mutants *ein5* and *ein6*, will certainly expand our knowledge of the ethylene signal transduction pathway.

Genetic engineering of ethylene sensitivity

Current progress in the understanding of ethylene perception and signal transduction pathway at the molecular level provides potential methods for the genetic engineering of ethylene sensitivity in plants. Transgenic plants with altered ethylene sensitivity should promote the understanding of

how plants regulate the sensitivity to ethylene. They are also useful for crop improvement.

On the basis of the model of ethylene perception and signal transduction pathway in plants (Figure 2), various strategies for altering ethylene sensitivity have been provided. Studies of ethylene receptors from *Arabidopsis* have suggested that these receptors are negative regulators of the ethylene response. A loss of function mutation would then create a plant with a constitutive ethylene response, since it would have lost the ability to repress signalling. A mutation of the ethylene binding domain would create a plant that is insensitive to ethylene, since it would have lost the ability to bind ethylene and would remain in the OFF position. A semi-dominant version of this mutation is found in *Nr* tomato plants and results in ethylene insensitivity, so that fruits fail to ripen⁵². Other tomato receptor proteins⁵² analogous to the *Arabidopsis* family of receptor proteins include LeETR1, 2, 3, 4, 5 and NR. Various attempts have been made to alter the expression of these receptors with the aim of changing the ethylene response. When one of the receptor genes is expressed in a sense direction, the amount of the ethylene receptor protein should increase in the transgenic plants. Consequently, the transgenic plants should show reduced sensitivity to ethylene because a large amount of ethylene is required to reject the inactivation of *CTR1* by ethylene receptors, which result in the activation of *EIN2* in the transgenic plant compared to the wild type plant. Another example is when an antisense version of the *LeETR4* gene was used to lower the amount of mRNA translated, tomato plants exhibited severe epinasty and faster fruit ripening⁵². However, the number of transgenic plants with the sense gene is lower than those with the antisense gene or mutant gene, suggesting some function of the sense gene in the transgenic plant. On the other hand, transgenic plants expressing the antisense gene of ethylene receptor should show increased sensitivity to ethylene, because the transgenic plants will require a small amount of ethylene for rejecting the down regulation of *EIN2* compared to the wild type plants.

Analysis of ethylene receptor proteins and mutant plants shows that the former have two important residues for their function, residues responsible for ethylene binding and histidine kinase activity. Therefore, if we introduced mutation in these residues and transform these genes to plants, it is expected that the transgenic plants will show altered sensitivity to ethylene. The receptor protein with a mutation in ethylene binding residue cannot bind ethylene and constitutively activates *CTR1* even in the presence of ethylene. Transgenic plants expressing the mutant receptor should confer insensitivity to ethylene. *etr1* mutants of *Arabidopsis* have mutation in such sites of the ETR1 protein¹³. When the *etr1-1* gene was introduced into tomato and petunia, both transgenic plants showed insensitivity to ethylene⁹¹. On the other hand, when the ethylene receptor protein with a mutation in the residue responsible for histidine kinase activity is overexpressed, competition for

ethylene binding between mutants and wild type proteins could occur. Consequently, a large amount of ethylene is required to stop *CTR1* activation. Transgenic plants should show reduced sensitivity to ethylene. Table 1 contains a list of plants with altered sensitivity to ethylene, created by manipulation or insertion of genes from the ethylene response pathway.

Drought is one of the most important abiotic stresses affecting the productivity of maize. Previous studies have shown that expression of a mitogen-activated protein kinase kinase kinase (MAPKKK) gene activated an oxidative signal cascade and led to the tolerance of freezing, heat, and salinity stress in transgenic tobacco. To analyse the role of activation of oxidative stress signalling in improving drought tolerance in major crops, Shou *et al.*⁹² expressed a tobacco MAPKKK (*NPK1*) in maize. Results show that *NPK1* expression enhanced drought tolerance in transgenic maize. Under drought conditions, transgenic maize plants maintained significantly higher photosynthesis rates than did the non-transgenic control, suggesting that *NPK1* induced a mechanism that protected the photosynthesis machinery from dehydration damage. In addition, drought-stressed transgenic plants produced kernels with weights similar to those under well-watered conditions, while kernel weights of drought-stressed non-transgenic control plants were significantly reduced when compared with their non-stressed counterparts.

In the case of using the components of the ethylene signalling pathway, two strategies, expression of sense or antisense genes, will be effective in regulating ethylene sensitivity. The *ctr1* null mutant showed constitutive sensitivity to ethylene⁸. Therefore, if we express *CTR1* and its homologues in a sense direction, the transgenic plants might show reduced sensitivity. However, if we express the gene in an antisense direction, transgenic plants should show increased sensitivity. *ein 2* and *ein 3* mutants showed insensitivity to ethylene^{7,51}. Therefore, if we overexpress *EIN2*, *EIN3* and the homologues in a sense direction, transgenic plants should show the constitutive response to ethylene, while if we express them in an antisense direction, transgenic plants should show reduced response. Actually, overexpression of *EIN3* in *Arabidopsis* conferred the constitutive ethylene response⁶⁹. Another example, a loss-of-function mutation in the copper transport system (*ran1*) that is essential for ethylene action, was used to create an *Arabidopsis* plant with relaxed ligand specificity⁵³. The result of this mutation is a constitutive triple response (*ctr*) *Arabidopsis* mutant found to have a recessive mutation in a serine/threonine protein kinase usually involved in ethylene signalling⁸. Thus, a mutation in the copper transporter responsible for providing copper ions to receptors in the plant secretory pathway causes the formation of receptors that are not selective and allows a response in the absence of specific signals.

Overexpression of DNA-binding elements in the ethylene response pathway, denoted as ethylene-responsive element

Table 1. Plants with altered ethylene perception

Gene/promoter	Consequence	Plant transformed	Reference
<i>At etr1-1</i> with CaMV 35S N-terminus of <i>etr1-1</i> fused to histidine kinase domain of tomato NR cDNA with FMV 35S	Tomato: Delayed abscission of flowers and ripening of fruit Petunia: Delayed abscission and senescence	Tomato and Petunia	91
<i>At etr1-1</i> with its own promoter	Enhanced basal ethylene production Sensitivity to ABA, no C ₂ H ₄ feedback control Reduced leaf senescence Non-host sensitivity to soil fungus	Tobacco	98
<i>ran1-1</i> ; <i>ran1-2</i> ; <i>eto1</i> and <i>ctr1</i> with CaMV 35S	<i>ran-1</i> caused constitutive ethylene response <i>ran1-1</i> and <i>ran1-2</i> are allelic	<i>Arabidopsis</i>	53
Antisense <i>LeETR4</i> and antisense <i>NR</i>	Lowered level of <i>LeETR4</i> mRNA Severe epinasty Enhanced flower senescence Accelerating fruit ripening Reduced level of <i>NR</i> mRNA Normal ethylene sensitivity	Tomato	52
<i>NR</i> cDNA with FMV promoter	Lower sensitivity to ethylene than <i>NR</i> mutant	Tomato	99
<i>NR</i> antisense with CaMV 35S promoter	Fruit ripened normally; levels of <i>PSY1</i> , <i>ACO1</i> (ripening-related genes) and <i>E4</i> (ethylene responsive genes) were normal	Tomato	100
<i>Tsi1</i> with CaMV 35S promoter	No increased transcription of genes with DRE/CRT box Tolerance to high salt Tolerance to bacterial inoculation	Tobacco	83
<i>LeETR1</i> with antisense receiver domain	Delayed abscission Reduced plant size Normal fruit ripening Normal triple response	Tomato	97
Two copies of <i>Pti4</i> cDNA from tomato with CaMV 35S promoter	Constitutive ethylene response Expression of GCC box containing PR proteins	<i>Arabidopsis</i>	93
Cosuppression of <i>PhEIN2</i> and <i>PhEIL3</i>	Decreased sensitivity to ethylene Five times longer flower life Three times as many flowers as control	<i>Petunia</i>	99
<i>At etr1-1</i> with CaMV 35S promoter	Anther development unaffected Development of ovaries and ovule unaffected Final event of dehiscence delayed	Tobacco	101
<i>NPK1</i> with CaMV 35S promoter	Enhanced drought tolerance Higher photosynthetic rate High kernel weights	Maize	92
<i>Cm-ERS1/H70A</i> with CaMV 35S promoter	Reduced ethylene sensitivity Increased flowering duration Enhances formation of infection threads and nodule primordia	<i>Lotus japonicus</i>	102
<i>NTHK1</i> with CaMV 35S	Reduced ethylene sensitivity Induction of <i>AtLecRK2</i> in response to salt stress Induction inhibited by <i>NTHK1</i>	Tobacco	103
<i>At ETR1</i> with CaMV 35S	Exposure to NaCl reduced expression of <i>ETR1</i> Plant response to abiotic stress	<i>Arabidopsis</i>	104
<i>At-ERS1</i> with CaMV 35S	Leaf and flower senescence delayed Ethylene-insensitive phenotype	<i>Arabidopsis</i>	105

binding factors, has been used to study their role in ethylene action and stress tolerance. For example, in one study an oilseed rape salt-induced transcript was used to produce a probe for a tobacco cDNA library. The sequence isolated was named *Tsi1*, for tobacco stress-induced-1, and was then overexpressed in tobacco to study the effects on ethylene dependent transcription. In this experiment, results included transcription of pathogen-related proteins, an increased tolerance to high salt, and increased pathogen resistance⁸³. Wu *et al.*⁹³ used the same approach to study the function of a tomato transcription factor, *Pti4*. When expressed in *Arabidopsis*, under the control of a strong constitutive promoter, there was an increased expression of GCC box-containing genes. This sequence has been associated with a set of ethylene responsive genes that among other things, encode pathogen resistance⁹⁴. These examples demonstrate that the ethylene response pathway is conserved in different plants so that elements of this pathway can be genetically manipulated, to change the amount and type of ethylene inducible genes that are expressed.

Through the analysis of ethylene insensitive mutants and transgenic plants of *Arabidopsis*, tomato and petunia^{6,22,91,95}, it is expected that transgenic plants conferring reduced sensitivity or insensitivity to ethylene show altered phenotypes like long shelf-life of fruits, flowers and leaves, and delayed growth transition from vegetative to reproductive growth. These alterations will be useful for a variety of crops with commercial importance.

The ripening of climacteric fruits, including apple, avocado, melon, tomato, banana, peach and persimmon⁹⁶ is rapidly progressed by ethylene. Abscission in cut flowers like carnation, rose, snapdragon and sweet pea, and potted plants like Christmas cactus, *Impatiens* and *Pelargonium* is also progressed by ethylene⁹⁶. In order to prevent ripening, senescence and abscission of these crops, a variety of storage systems like controlled atmosphere storage and hypobaric storage have been developed. These systems sometimes result in the crops becoming more expensive. Alternatively, the crops have been harvested at the immature stage for extending the post-harvest life. However, harvest at the immature stage results in problems like low quality of fruits and less volume of cut-flowers. Crops conferring insensitivity or reduced sensitivity to ethylene could reduce post-harvest loss. They allow the storage of crops without specialized storage systems and such crops may be harvested at the mature stage. This results in reducing the cost and increasing the quality. Moreover, these transgenic plants will contribute to reduce post-harvest losses in countries like India, where we do not have good storage systems for crops. Bolting of Chinese cabbage, lettuce and spinach limits the period of their production. If we can delay the bolting time of these crops, it will be possible to cultivate them for a longer period. Since ethylene-insensitive plants tend to delay bolting time^{6,95}, genetically engineered crops conferring insensitivity or reduced sensitivity to ethylene could contribute to overcoming this problem as well.

The above-mentioned results suggest that ethylene production either increases due to the lack of negative feedback when receptors are non-functional or decreases when ethylene binding is impaired, but mutations in or truncations of the receiver domain only confer partial ethylene insensitivity. Whitelaw *et al.*⁹⁷, for example, saw tomato flowers stay on the stem longer in plants with *LeETR1* with an inverted receiver domain; yet these plants had a normal triple response. For each type of manipulation of the receptor proteins, there is a different response and more research is needed to clarify their precise role in ethylene sensitivity.

Conclusion/perspective

As knowledge of the ethylene response in plants increases, the number of strategies for altering this response is also increasing. There is considerable commercial interest in developing fruits that will not ripen until given a specific external cue, or having flowers with an extended shelf life, or plants that are able to withstand a range of environmental stresses. By modulating ethylene levels, the production of transgenic plants that are more robust than their non-transformed counterparts in the face of pathogen attack, flooding, drought, or high salinity is readily attainable for a variety of plants. Ethylene is a pivotal signalling molecule, and while its connection to all plant processes is not completely understood, a picture is emerging of a simple molecule whose concentration can be manipulated to create many desirable traits in plants. Understanding molecular events that lead to the alteration of ethylene sensitivity in transgenic plants with ethylene receptor genes may be a clue to elucidate the mechanism of how plants regulate the sensitivity to ethylene. Since the differences in the expression of each ethylene receptor gene may account for the regulation of sensitivity to ethylene, it is necessary that the mechanisms of how plants regulate the expression of ethylene receptor genes be understood. Consequently, analysis of promoters of ethylene receptor genes and the trans-acting factors will be required. The knowledge obtained by such analysis will contribute not only to the explanation of how plants regulate their sensitivity to ethylene, but also to the application of genetic engineering of ethylene sensitivity to make crop improvements. Future studies to characterize the interaction among pathway components will reveal more detailed information about how ethylene synthesis and signalling are regulated and how they may interact with components of other pathways. One particularly useful approach using the whole genome-based DNA chip technology will be obviously an effective means to examine the regulation of expression of ethylene and other hormone/stress signalling genes.

1. Johnson, P. R. and Ecker, J. R., The ethylene gas signal transduction pathway: A molecular perspective. *Annu. Rev. Genet.*, 1998, **32**, 227–254.

2. Ecker, J. R., The ethylene signal transduction pathway in plants. *Science*, 1995, **268**, 667–675.
3. Zarembinski, T. I. and Theologis, A., Ethylene biosynthesis and action: A case of conservation. *Plant Mol. Biol.*, 1994, **26**, 1579–1597.
4. Imaseki, H., Control of ethylene synthesis and metabolism. In *Biochemistry and Molecular Biology of Plant Hormones* (eds Hooykaas, P. J. J., Hall, M. A. and Libenga, K. R.), Elsevier, 1999.
5. Wang, K. L. and Ecker, J. R., Ethylene biosynthesis and signalling networks. *Plant Cell*, 2002, **14**, S131–S151.
6. Bleecker, A. B., Estelle, M. A., Somerville, C. and Kende, H., Insensitivity to ethylene conferred by a dominant mutation in *Arabidopsis thaliana*. *Science*, 1988, **241**, 1086–1089.
7. Guzman, P. and Ecker, J. R., Exploiting the triple response of *Arabidopsis* to identify ethylene-related mutants. *Plant Cell*, 1990, **2**, 513–523.
8. Kieber, J. J., Rothenberg, M., Roman, G., Feldmann, K. A. and Ecker, J. R., CTR1, a negative regulator of the ethylene response pathway in *Arabidopsis*, encodes a member of the raf family of protein kinases. *Cell*, 1993, **72**, 427–441.
9. Roman, G. and Ecker, J. R., Genetic analysis of a seedling stress response to ethylene in *Arabidopsis*. *Philos. Trans. R. Soc. London, Ser. B.*, 1995, **350**, 75–81.
10. Solano, R. and Ecker, J. R., Ethylene gas: Perception, signalling and response. *Curr. Opin. Plant Biol.*, 1998, **1**, 393–398.
11. Stepanova, A. N. and Ecker, J. R., Ethylene signalling: From mutants to molecules. *Curr. Opin. Plant Biol.*, 2000, **3**, 353–360.
12. Stearns, J. C. and Glick, B. R., Transgenic plants with altered ethylene biosynthesis or perception. *Biotechnol. Adv.*, 2003, **21**, 193–210.
13. Chang, C., Kwok, S. F., Bleecker, A. B. and Meyerowitz, E. M., *Arabidopsis* ethylene-response gene *ETR1*: Similarity of product to two-component regulators. *Science*, 1993, **262**, 539–544.
14. Sakai, H., Hua, J., Chen, Q. G., Chang, C., Medrano, L. J., Bleecker, A. B. and Meyerowitz, E. M., *ETR2* is an *ETR1*-like gene involved in ethylene signalling in *Arabidopsis*. *Proc. Natl. Acad. Sci. USA*, 1998, **95**, 5812–5817.
15. Hua, J., Chang, C., Sun, Q. and Meyerowitz, E. M., Ethylene insensitivity conferred by *Arabidopsis ERS* gene. *Science*, 1995, **269**, 1712–1714.
16. Wilkinson, J. Q., Lanahan, M. B., Yen, H. C., Giovannoni, J. J. and Klee, H. J., An ethylene-inducible component of signal transduction encoded by *Never-ripe*. *Science*, 1995, **270**, 1807–1809.
17. Schaller, G. E. and Bleecker, A. B., Ethylene-binding sites generated in yeast expressing the *Arabidopsis ETR1* gene. *Science*, 1995, **270**, 1809–1811.
18. Schaller, G. E., Ladd, A. N., Lanahan, M. B., Spanbauer, J. M. and Bleecker, A. B., The ethylene response mediator *ETR1* from *Arabidopsis* forms a disulfide-linked dimer. *J. Biol. Chem.*, 1995, **270**, 12526–12530.
19. Rodriguez, F. I., Esch, J. J., Hall, A. E., Binder, B. M., Schaller, G. E. and Bleecker, A. B., A copper cofactor for the ethylene receptor *ETR1* from *Arabidopsis*. *Science*, 1999, **283**, 996–998.
20. Hua, J. and Meyerowitz, E. M., Ethylene responses are negatively regulated by a receptor gene family in *Arabidopsis thaliana*. *Cell*, 1998, **94**, 261–271.
21. Hua, J., Sakai, H., Nourizadeh, S., Chen, Q. G., Bleecker, A. B., Ecker, J. R. and Meyerowitz, E. M., *EIN4* and *ERS2* are members of the putative ethylene-receptor gene family in *Arabidopsis*. *Plant Cell*, 1998, **10**, 1321–1332.
22. Lanahan, M. B., Yen, H.-C., Giovannoni, J. J. and Klee, H. J., The never ripe mutation blocks ethylene perception in tomato. *Plant Cell*, 1994, **6**, 521–530.
23. Payton, S., Fray, R. G., Brown, S. and Grierson, D., Ethylene receptor expression is regulated during fruit ripening, flower senescence and abscission. *Plant Mol. Biol.*, 1996, **31**, 1227–1231.
24. Zhou, D., Kalaitzis, P., Mattoo, A. K. and Tucker, M. L., The mRNA for an *ETR1* homologue in tomato is constitutively expressed in vegetative and reproductive tissues. *Plant Mol. Biol.*, 1996, **30**, 1331–1338.
25. Lashbrook, C. C., Tieman, D. M. and Klee, H. J., Differential regulation of the tomato *ETR* gene family throughout plant development. *Plant J.*, 1998, **15**, 243–252.
26. Tieman, D. M. and Klee, H. J., Differential expression of two novel members of the tomato ethylene receptor family. *Plant Physiol.*, 1999, **120**, 165–172.
27. Bleecker, A. B., Ethylene perception and signalling: An evolutionary perspective. *Trends Plant Sci.*, 1999, **4**, 269–274.
28. Vriezen, W. H., van Rijn, C. P. E., Voesenek, L. A. C. J. and Mariani, C., A homolog of the *Arabidopsis thaliana ERS* gene is actively regulated in *Rumex palustris* upon flooding. *Plant J.*, 1997, **11**, 1265–1271.
29. Sato-Nara, K., Yuhashi, K., Higashi, K., Hosoya, K., Kubota, M. and Ezura, H., Isolation and expression of a *ETR1* homolog in melon (*Cucumis melo* L. *reticulatus*). In 5th International Congress Plant Mol. Biol., Abstr. No. 840, Singapore, 1997.
30. Sato-Nara, K., Yuhashi, K., Higashi, K., Hosoya, K., Kubota, M. and Ezura, H., Stage- and tissue-specific expression of ethylene receptor homolog genes during fruit development in muskmelon. *Plant Physiol.*, 1999, **120**, 321–329.
31. Mita, S., Kawamura, S., Yamawaki, K., Nakamura, K. and Hyodo, H., Differential expression of genes involved in biosynthesis and perception of ethylene during ripening of passion fruit. *Plant Cell Physiol.*, 1998, **39**, 1209–1217.
32. Dervinis, C., Clark, D. G., Barrett, J. E. and Nell, T. A., Effect of pollination and exogenous ethylene on accumulation of *ETR1* homologue transcripts during flower petal abscission in geranium (*Pelargonium × hortorum* L. H. Bailey). *Plant Mol. Biol.*, 2000, **42**, 847–856.
33. Xie, C., Zhang, Z. G., Zhang, J. S., He, X. J., Cao, W. H., He, S. J. and Chen, S. Y., Spatial expression and characterization of a putative ethylene receptor protein NTHK1 in tobacco. *Plant Cell Physiol.*, 2002, **43**, 810–815.
34. Bassett, C. L., Artlip, T. S. and Callahan, A. M., Characterization of the peach homologue of the ethylene receptor, *PpETR1*, reveals some unusual features regarding transcript processing. *Planta*, 2002, **215**, 679–688.
35. Terajima, Y. *et al.*, Molecular cloning and characterization of a cDNA for a novel ethylene receptor, NT-ERS1, of tobacco (*Nicotiana tabacum* L.). *Plant Cell Physiol.*, 2001, **42**, 308–313.
36. El-Sharkawy, I., Jones, B., Li, Z. G., Lelievre, J. M., Pech, J. C. and Latche, A., Isolation and characterization of four ethylene perception elements and their expression during ripening in pears (*Pyrus communis* L.) with/without cold requirement. *J. Exp. Bot.*, 2003, **54**, 1615–1625.
37. Watanabe, H., Saigusa, M., Hase, S., Hayakawa, T. and Satoh, S., Cloning of a cDNA encoding an *ETR2*-like protein (*Os-ERL1*) from deep water rice (*Oryza sativa* L.) and increase in its mRNA level by submergence, ethylene and gibberellin treatments. *J. Exp. Bot.*, 2004, **55**, 1145–1148.
38. Woltering, E. J. and van Doorn, W. G., Role of ethylene in senescence of petals – morphological and taxonomical relationships. *J. Exp. Bot.*, 1988, **39**, 1605–1616.
39. Serek, M., Jones, R. B. and Reid, M. S., Role of ethylene in opening and senescence of *Gladiolus* sp. flowers. *J. Am. Soc. Hortic. Sci.*, 1994, **119**, 1014–1019.
40. Arora, A. and Ezura, H., Molecular cloning and characterization of a novel ethylene receptor homologue gene isolated from ethylene-insensitive flowers of *Gladiolus* (*Gladiolus grandiflora* hort.). *Plant Mol. Biol.*, 2005 (accepted).
41. Arora, A. and Ezura, H., Cloning and characterization of ethylene receptor genes from ethylene-insensitive plant, *Gladiolus grandiflora*. In 7th International Congress of Plant Molecular Biology, Barcelona, 23–28 June 2003, p. 134.

42. Arora, A. and Ezura, H., The role of ethylene receptor in ethylene-insensitive *Gladiolus*. Paper presented in 'Plant senescence and programmed cell death' Gordon Research Conference, Mount Holyoke College, Massachusetts, USA, 27 June to 2 July 2004.
43. Yau, C. P., Wang, L., Yu, M., Zee, S. Y. and Yip, W. K., Differential expression of three genes encoding an ethylene receptor in rice during development, and in response to indole-3-acetic acid and silver ions. *J. Exp. Bot.*, 2004, **55**, 547–556.
44. Abel, S. and Theologis, A., Early genes and auxin action. *Plant Physiol.*, 1996, **111**, 9–17.
45. Jun, S. H., Han, M. J., Lee, S., Seo, Y. S., Kim, W. T. and An, G., *OsEIN2* is a positive component in ethylene signalling in rice. *Plant Cell Physiol.*, 2004, **45**, 281–289.
46. Wurgler-Murphy, S. M. and Saito, H., Two-component signal transducers and MAPK cascades. *Trends Biochem. Sci.*, 1997, **22**, 172–176.
47. Pirrung, M. C., Histidine kinases and two-component signal transduction systems. *Chem. Biol.*, 1999, **6**, R167–R175.
48. Hall, A. E., Findell, J. L., Schaller, G. E., Sisler, E. C. and Bleecker, A. B., Ethylene perception by the ERS1 protein in *Arabidopsis*. *Plant Physiol.*, 2000, **123**, 1449–1458.
49. Fankhauser, C., Yeh, K. C., Lagarias, J. C., Zhang, H., Elich, T. D. and Chory, J., PKS1, a substrate phosphorylated by phytochrome that modulates light signalling in *Arabidopsis*. *Science*, 1999, **284**, 1539–1541.
50. Moussatche, P. and Klee, H. J., Autophosphorylation activity of the *Arabidopsis* ethylene receptor multigene family. *J. Biol. Chem.*, 2004, **279**, 48734–48741.
51. Roman, G., Lubarsky, B., Kieber, J. J., Rothenberg, M. and Ecker, J. R., Genetic analysis of ethylene signal transduction in *Arabidopsis thaliana*: Five novel mutant loci integrated into a stress response pathway. *Genetics*, 1995, **139**, 1393–1409.
52. Tieman, D. M., Taylor, M. G., Ciardi, J. A. and Klee, H. J., The tomato ethylene receptors *NR* and *LeETR4* are negative regulators of ethylene response and exhibit functional compensation within a multigene family. *Proc. Natl. Acad. Sci. USA*, 2000, **97**, 5663–5668.
53. Hirayama, T. *et al.*, *RESPONSIVE-TO-ANTAGONIST1*, a Menkes/Wilson disease-related copper transporter, is required for ethylene signalling in *Arabidopsis*. *Cell*, 1999, **97**, 383–393.
54. Woeste, K. E. and Kieber, J. J., A strong loss-of-function mutation in *RAN1* results in constitutive activation of the ethylene response pathway as well as a rosette-lethal phenotype. *Plant Cell*, 2000, **12**, 443–455.
55. Kyriakis, J. M., App, H., Zhang, X. F., Banerjee, P., Brautigan, D. L., Rapp, U. R. and Avruch, J., Raf-1 activates MAP kinase-kinase. *Nature*, 1992, **358**, 417–421.
56. Pelech, S. L. and Sanghera, J. S., Mitogen-activated protein kinases: Versatile transducers for cell signalling. *Trends Biochem. Sci.*, 1992, **17**, 233–238.
57. Clark, K. L., Larsen, P. B., Wang, X. and Chang, C., Association of the *Arabidopsis* *CTR1* Raf-like kinase with the *ETR1* and *ERS* ethylene receptors. *Proc. Natl. Acad. Sci. USA*, 1998, **95**, 5401–5406.
58. Urao, T., Miyata, S., Yamaguchi-Shinozaki, K. and Shinozaki, K., Possible His to Asp phosphorelay signalling in an *Arabidopsis* two-component system. *FEBS Lett.*, 2000, **478**, 227–232.
59. Ouaked, F., Rozhon, W., Lecourieux, D. and Hirt, H., A MAPK pathway mediates ethylene signalling in plants. *EMBO J.*, 2003, **22**, 1282–1288.
60. Frye, C. A., Tang, D. and Innes, R. W., Negative regulation of defense responses in plants by a conserved MAPKK kinase. *Proc. Natl. Acad. Sci. USA*, 2001, **98**, 373–378.
61. Pan, Z. and Chang, C., Functional complementation of the *Schizosaccharomyces pombe* *wis1* mutant by *Arabidopsis* *MEK1* and non-catalytic enhancement by *CTR1*. *FEBS Lett.*, 1999, **459**, 405–410.
62. Mikula, M. *et al.*, Embryonic lethality and fetal liver apoptosis in mice lacking the *c-raf-1* gene. *EMBO J.*, 2001, **20**, 1952–1962.
63. Kiegerl, S. *et al.*, SIMKK, a mitogen-activated protein kinase (MAPK) kinase, is a specific activator of the salt stress-induced MAPK, SIMK. *Plant Cell*, 2000, **12**, 2247–2258.
64. Alonso, J. M., Hirayama, T., Roman, G., Nourizadeh, S. and Ecker, J. R., *EIN2*, a bifunctional transducer of ethylene and stress responses in *Arabidopsis*. *Science*, 1999, **284**, 2148–2152.
65. Fujita, H. and Syono, K., Genetic analysis of the effects of polar auxin transport inhibitors on root growth in *Arabidopsis thaliana*. *Plant Cell Physiol.*, 1996, **37**, 1094–1101.
66. Su, W. P. and Howell, S. H., A single genetic-locus, *ckr1*, defines *Arabidopsis* mutants in which root-growth is resistant to low concentrations of cytokinin. *Plant Physiol.*, 1992, **99**, 1569–1574.
67. Beaudoin, N., Serizet, C., Gosti, F. and Giraudat, J., Interactions between abscisic acid and ethylene signalling cascades. *Plant Cell*, 2000, **12**, 1103–1115.
68. Ghassemian, M., Nambara, E., Cutler, S., Kawaide, H., Kamiya, Y. and McCourt, P., Regulation of abscisic acid signalling by the ethylene response pathway in *Arabidopsis*. *Plant Cell*, 2000, **12**, 1117–1126.
69. Oh, S. A., Park, J. H., Lee, G. I., Paek, K. H., Park, S. K. and Nam, H. G., Identification of three genetic loci controlling leaf senescence in *Arabidopsis thaliana*. *Plant J.*, 1997, **12**, 527–535.
70. Alonso, J. M., Stepanova, A. N., Solano, R., Wisman, E., Ferrari, S., Ausubel, F. M. and Ecker, J. R., Five components of the ethylene-response pathway identified in a screen for weak ethylene-insensitive mutants in *Arabidopsis*. *Proc. Natl. Acad. Sci. USA*, 2003, **100**, 2992–2997.
71. Chao, Q., Rothenberg, M., Solano, R., Roman, G., Terzaghi, W. and Ecker, J. R., Activation of the ethylene gas response pathway in *Arabidopsis* by the nuclear protein ETHYLENE-INSENSITIVE3 and related proteins. *Cell*, 1997, **89**, 1133–1144.
72. Kosugi, S. and Ohashi, Y., Cloning and DNA-binding properties of a tobacco *Ethylene-insensitive3* (*EIN3*) homolog. *Nucleic Acids Res.*, 2000, **28**, 960–967.
73. Tieman, D. M., Ciardi, J. A., Taylor, M. G. and Klee, H. J., Members of the tomato *LeEIL* (*EIN3*-like) gene family are functionally redundant and regulate ethylene responses throughout plant development. *Plant J.*, 2001, **26**, 47–58.
74. Solano, R., Stepanova, A., Chao, Q. and Ecker, J. R., Nuclear events in ethylene signalling: A transcriptional cascade mediated by ETHYLENE-INSENSITIVE3 and ETHYLENE-RESPONSE-FACTOR1. *Genes Dev.*, 1998, **12**, 3703–3714.
75. Riechmann, J. L. and Meyerowitz, E. M., The AP2/EREBP family of plant transcription factors. *Biol. Chem.*, 1998, **379**, 633–646.
76. Yamamoto, S., Suzuki, K. and Shinshi, H., Elicitor-responsive, ethylene-independent activation of GCC box-mediated transcription that is regulated by both protein phosphorylation and dephosphorylation in cultured tobacco cells. *Plant J.*, 1999, **20**, 571–579.
77. Ohme-Takagi, M. and Shinshi, H., Ethylene-inducible DNA binding proteins that interact with an ethylene-responsive element. *Plant Cell*, 1995, **7**, 173–182.
78. Buttner, M. and Singh, K. B., *Arabidopsis thaliana* ethylene-responsive element binding protein (AtEBP), an ethylene-inducible, GCC box DNA-binding protein, interacts with an ocs element binding protein. *Proc. Natl. Acad. Sci. USA*, 1997, **94**, 5961–5966.
79. Suzuki, K., Suzuki, N., Ohme-Takagi, M. and Shinshi, H., Immediate early induction of mRNAs for ethylene-responsive transcription factors in tobacco leaf strips after cutting. *Plant J.*, 1998, **15**, 657–665.
80. Thara, V. K., Tang, X., Gu, Y. Q., Martin, G. B. and Zhou, J. M., *Pseudomonas syringae* pv *tomato* induces the expression of tomato EREBP-like genes *Pti4* and *Pti5* independent of ethylene, salicylate and jasmonate. *Plant J.*, 1999, **20**, 475–483.
81. Fujimoto, S. Y., Ohta, M., Usui, A., Shinshi, H. and Ohme-Takagi, M., *Arabidopsis* ethylene-responsive element binding

- factors act as transcriptional activators or repressors of GCC box-mediated gene expression. *Plant Cell*, 2000, **12**, 393–404.
82. Gu, Y. Q., Yang, C., Thara, V. K., Zhou, J. and Martin, G. B., *Pti4* is induced by ethylene and salicylic acid, and its product is phosphorylated by the Pto kinase. *Plant Cell*, 2000, **12**, 771–786.
 83. Park, C. J., Shin, R., Park, J. M., Lee, G. J., Yoo, T. H. and Paek, K. H., A hot pepper cDNA encoding a pathogenesis-related protein 4 is induced during the resistance response to tobacco mosaic virus. *Mol. Cell*, 2001, **11**, 122–127.
 84. Guo, H. and Ecker, J. R., Plant responses to ethylene gas are mediated by SCF^{EBF1/EBF2}-dependent proteolysis of EIN3 transcription factor cell. *Cell*, 2003, **115**, 667–677.
 85. Gagne, J. M., Smalle, J., Gingerich, D. J., Walker, J. M., Yoo, S. D., Yanagisawa, S. and Vierstra, R. D., *Arabidopsis* EIN3-binding F-box 1 and 2 form ubiquitin-protein ligases that repress ethylene action and promote growth by directing EIN3 degradation. *Proc. Natl. Acad. Sci. USA*, 2004, **101**, 6803–6808.
 86. Yanagisawa, S., Yoo, S.-D. and Sheen, J., Differential regulation of EIN3 stability by glucose and ethylene signalling in plants. *Nature*, 2003, **425**, 521–525.
 87. Potuschak, T., Lechner, E., Parmentier, Y., Yanagisawa, S., Grava, S., Koncz, C. and Genschik, P., EIN3-dependent regulation of plant ethylene hormone signalling by two *Arabidopsis* F-box proteins: EBF1 and EBF2. *Cell*, 2001, **115**, 679–689.
 88. Larsen, P. B. and Chang, C., The *Arabidopsis eer1* mutant has enhanced ethylene responses in the hypocotyl and stem. *Plant Physiol.*, 2001, **125**, 1061–1073.
 89. Barry, C. S., Fox, E. A., Yen, H., Lee, S., Ying, T., Grierson, D. and Giovannoni, J., Analysis of the ethylene response in the epinastic mutant of tomato. *Plant Physiol.*, 2001, **127**, 58–66.
 90. Giovannoni, J. *et al.*, Genetic mapping of ripening and ethylene-related loci in tomato. *Theor. Appl. Genet.*, 1999, **98**, 1005–1013.
 91. Wilkinson, J. Q., Lanahan, M. B., Clark, D. G., Bleecker, A. B., Chang, C. and Meyerowitz, E. M., A dominant mutant receptor for *Arabidopsis* confers ethylene insensitivity in heterologous plants. *Nature Biotechnol.*, 1997, **15**, 444–447.
 92. Shou, H., Bordallo, P. and Wang, K., Expression of the *Nicotiana* protein kinase (*NPK1*) enhanced drought tolerance in transgenic maize. *J. Exp. Bot.*, 2004, **55**, 1013–1019.
 93. Wu, K., Tian, L., Hollingworth, J., Brown, D. C. and Miki, B., Functional analysis of tomato *Pti4* in *Arabidopsis*. *Plant Physiol.*, 2002, **128**, 30–37.
 94. Zhou, J., Tang, X. and Martin, G. B., The Pto kinase conferring resistance to tomato bacterial speck disease interacts with proteins that bind a *cis*-element of pathogenesis-related genes. *EMBO J.*, 1997, **16**, 3207–3218.
 95. Ogawara, T., Higashi, K., Kamada, H. and Ezura, H., Ethylene advances the transition from vegetative growth to flowering in *Arabidopsis thaliana*. *J. Plant Physiol.*, 2003, **160**, 1335–1340.
 96. Abeles, F. B., Morgan, P. W. and Saltveit, Jr. M. E., In *Ethylene in Plant Biology*, Academic Press, New York, 1992, 2nd edn.
 97. Whitelaw, C. A., Lyssenko, N. N., Chen, L., Zhou, D., Mattoo, A. K. and Tucker, M. L., Delayed abscission and shorter internodes correlate with a reduction in the ethylene receptor *LeETR1* transcript in transgenic tomato. *Plant Physiol.*, 2002, **128**, 978–987.
 98. Knoester, M., van Loon, L. C., van den Heuvel, J., Bol, J. F. and Linthorst, H. J. M., Ethylene-insensitive tobacco lacks nonhost resistance against soil-borne fungi. *Proc. Natl. Acad. Sci. USA*, 1998, **95**, 1933–1937.
 99. Ciardi, J. A., Tieman, D. M., Lund, S. T., Jones, J. B., Stall, R. E. and Klee, H. J., Response to *Xanthomonas campestris* pv. *vesicatoria* in tomato involves regulation of ethylene receptor gene expression. *Plant Physiol.*, 2000, **123**, 81–92.
 100. Hackett, R. M., Ho, C. W., Lin, Z., Foote, H. C., Fray, R. G. and Grierson, D., Antisense inhibition of the *Nr* gene restores normal ripening to the tomato Never-ripe mutant, consistent with the ethylene receptor-inhibition model. *Plant Physiol.*, 2000, **124**, 1079–1086.
 101. Rieu, I., Wolters-Arts, M., Derksen, J., Mariani, C. and Weterings, K., Ethylene regulates the timing of anther dehiscence in tobacco. *Planta*, 2003, **217**, 131–137.
 102. Nukui, N., Ezura, H. and Minamisawa, K., Transgenic *Lotus japonicus* with an ethylene receptor gene *Cm-ERS1/H70A* enhances formation of infectious threads and nodule primordia. *Plant Cell Physiol.*, 2004, **45**, 427–435.
 103. He, X. J., Zhang, Z. G., Yan, D. O., Zhang, J. S. and Chen, S. Y., A salt-responsive receptor-like kinase gene regulated by the ethylene signalling pathway encodes a plasma membrane serine/threonine kinase. *Theor. Appl. Genet.*, 2004, **109**, 377–383.
 104. Zhao, X. C. and Schaller, G. E., Effect of salt and osmotic stress upon expression of the ethylene receptor ETR1 in *Arabidopsis thaliana*. *FEBS Lett.*, 2004, **562**, 189–192.
 105. Wang, Y. and Kumar, P. P., Heterologous expression of *Arabidopsis* ERS1 causes delayed senescence in coriander. *Plant Cell Rep.*, 2004, **22**, 678–683.

ACKNOWLEDGEMENTS. I thank the Department of Science and Technology, New Delhi and Japanese Society for the Promotion of Sciences, Japan for providing the opportunity for advanced studies in the area of ethylene signal transduction pathway.

Received 19 August 2004; revised accepted 14 June 2005