

**EXPERIMENTAL AND NUMERICAL STUDY ON
CONVERTED HYBRID ELECTRIC SCOOTER
परिवर्तित हाइब्रिड इलेक्ट्रिक स्कूटर पर प्रायोगिक एवं
संख्यात्मक अध्ययन**

JAY UPADHYAY

Thesis

Master of Technology

In Mechanical Engineering

(With Specialization in CAD/CAM)



2023

**Department of Mechanical Engineering
College of Technology and Engineering
Maharana Pratap University of Agriculture & Technology
Udaipur (Raj.)**

**EXPERIMENTAL AND NUMERICAL STUDY ON
CONVERTED HYBRID ELECTRIC SCOOTER**

**परिवर्तित हाइब्रिड इलेक्ट्रिक स्कूटर पर प्रायोगिक एवं
संख्यात्मक अध्ययन**

Thesis

Submitted to the

**Maharana Pratap University of Agriculture & Technology
Udaipur (Raj.)**

**In Partial Fulfilment of the Requirement for
the Degree of**

Master of Technology

in Mechanical Engineering

(With Specialization in CAD/CAM)



By

JAY UPADHYAY

2023

COLLEGE OF TECHNOLOGY AND ENGINEERING
MAHARANA PRATAP UNIVERSITY OF AGRICULTURE AND TECHNOLOGY
UDAIPUR

Date: / /2023

CERTIFICATE-I

CERTIFICATE OF ORIGINALITY

The research work embodied in this thesis titled “**Experimental and Numerical Study on Converted Hybrid Electric Scooter**” submitted for the award of degree of Master of Technology in Department of Mechanical Engineering of Maharana Pratap University of Agriculture and Technology, Udaipur (Raj.) is original and bonafide record of research work carried out by me under the supervision of **Dr. B.L. Salvi**, Associate Professor and Head, Department of Mechanical Engineering, College of Technology and Engineering, Udaipur. The contents of the thesis, either partially or fully, have not been submitted or will not be submitted to any other Institute or University for the award of any degree or diploma.

The work embodied in the thesis represents my ideas in my own words and where other ideas or words have been included, I have adequately cited and referenced the original sources. I also declare that I have adhered to all principles of academic honesty and integrity and have not misrepresented or fabricated or falsified any idea/data/fact/ source in my submission. I understand that any violation of the above will be cause for disciplinary action by the University and can also evoke penal action from the sources which have thus not been properly cited or from whom proper permission has not been taken when needed.

The manuscript has been subjected to plagiarism check by software URKUND.

It is certified that as per the check, the similarity index of the content is **0.0 %** and is within permissible limit as per the MPUAT guidelines on checking Plagiarism.

Date: / /2023

(Jay Upadhyay)

COLLEGE OF TECHNOLOGY AND ENGINEERING
MAHARANA PRATAP UNIVERSITY OF AGRICULTURE AND TECHNOLOGY
UDAIPUR

Date: / /2023

CERTIFICATE – II

This is to certify that this thesis entitled “**Experimental and Numerical Study on Converted Hybrid Electric Scooter**” submitted for the award of degree of **Master of Technology in Mechanical Engineering(CAD/CAM)** embodies bonafide research work carried out by **Mr. Jay Upadhyay** under my guidance and supervision and that no part of this thesis has been submitted for any other degree. The assistance and help received during the course of investigation have been fully acknowledged. The draft of the thesis was also approved by the advisory committee on / /2023.

The manuscript has been subjected to plagiarism check by software URKUND it is certified that as per the check, the similarity index of the content is **0.0 %** and is within permissible limit as per the MPUAT guidelines on checking Plagiarism.

(Dr. B.L. Salvi)

Head

Department of Mechanical Engineering
College of Technology and Engineering
Udaipur – 313001

(Dr. B.L. Salvi)

Major Advisor

Department of Mechanical Engineering
College of Technology and Engineering
Udaipur – 313001

(Dr. P.K. Singh)

DEAN

College of Technology and Engineering
Maharana Pratap University of Agriculture and Technology
Udaipur, Rajasthan

COLLEGE OF TECHNOLOGY AND ENGINEERING
MAHARANA PRATAP UNIVERSITY OF AGRICULTURE AND TECHNOLOGY
UDAIPUR

Date: / /2023

CERTIFICATE – III

This is to certify that this thesis entitled “**Experimental and Numerical Study on Converted Hybrid Electric Scooter**” submitted by **Mr. Jay Upadhyay** to Maharana Pratap University of Agriculture and Technology, Udaipur (Raj.) in partial fulfilment of the requirements for the degree of **Master of Technology in Mechanical Engineering (CAD/CAM)** after recommendation by the examiner was defended by candidate before the following members of examination committee. The performance of the candidate in the oral examination held on 20/06/2023 was found satisfactory; we therefore, recommended the thesis to be approved.

(Dr. B.L. Salvi)
Major Advisor

(Dr. M.S. Khidiya)
Advisor

(Dr. Chitranjan Agrawal)
Advisor

(Dr. Ranveer Singh Shekhawat)
DRI Nominee

(Dr. P.K. Singh)
DEAN
CTAE, Udaipur

(Dr. B.L. Salvi)
HEAD
Department of Mechanical Engineering

Approved / Not approved

DIRECTOR RESIDENCE INSTRUCTION

Maharana Pratap University of Agriculture and Technology
Udaipur, Rajasthan

COLLEGE OF TECHNOLOGY AND ENGINEERING
MAHARANA PRATAP UNIVERSITY OF AGRICULTURE AND TECHNOLOGY
UDAIPUR

Date: / /2023

CERTIFICATE – IV

This is to certify that **Mr. Jay Upadhyay** student of **Master of Technology in Mechanical Engineering(CAD/CAM)** has made all correction/modifications in this thesis entitled “**Experimental and Numerical Study on Converted Hybrid Electric Scooter**” which were suggested by the external examiner and the advisory committee in the oral examination held on 20/06/2023. The final copies of the thesis duly bound and corrected were submitted on / /2023.

(Dr. B.L. Salvi)

Head

Department of Mechanical Engineering
College of Technology and Engineering
Udaipur – 313001

(Dr. B.L. Salvi)

Major Advisor

Department of Mechanical Engineering
College of Technology and Engineering
Udaipur – 313001

ACKNOWLEDGEMENTS

I convey the feeling of immense gratitude to my major advisor **Dr. B. L. Salvi**, Associate Professor and Head, Department of Mechanical Engineering, College of Technology and Engineering, Udaipur, for his scholastic guidance, constructive criticism, constant encouragement and above all his corporative attitude right from the beginning that enabled me in bringing up this thesis in the present form.

I have an immense pleasure in expressing my deepest sense of gratitude and humble indebtedness towards my advisory committee **Dr. Chitranjan Agarwal**, Associate Professor, Department of Mechanical Engineering, **Dr. M.S. Khidiya**, Associate Professor, Department of Mechanical Engineering and **Dr. Ranveer Singh Shekhawat**, Assistant Professor, Department of Civil Engineering, as DRI Nominee, for their generous gestures and valuable suggestions in planning and execution of this study.

I am indebted to **Dr. B.L. Salvi**, Associate Professor and Head, Department of Mechanical Engineering, College of Technology and Engineering, Udaipur, for providing me all the needed facilities during the course of investigation.

I gratefully acknowledge the financial support received from New Generation Innovation and Entrepreneurship Development Centre (NewGen IEDC), College of Technology and Engineering, Udaipur, 313001, Rajasthan, a program of the Department of Science and Technology, Government of India during year 2021-22.

Words are insufficient to express my heartily thanks to my beloved friend Tanay Pansari, all other B.Tech. and M.Tech. students and other staff members for their help, support and encouragement. At the last but not the least, I think that the words are insufficient to express my deep sense of feeling and respect towards my parents, without their love it would not have been possible for me to complete this study.

Place : Udaipur, Rajasthan

Date : / /2023

(Jay Upadhyay)

CONTENTS

| Topic | Page No. |
|---|-----------------|
| Certificates | |
| Acknowledgements | |
| Contents | i-iii |
| List of Tables | iv |
| List of Figures | v-vii |
| List of Abbreviations | viii-ix |
| 1. INTRODUCTION | 1-7 |
| 1.1 General | 1 |
| 1.2 Current issues with the transportation system | 2 |
| 1.2.1 Environment and climate change issue | 2 |
| 1.2.2 Rising Energy Cost | 3 |
| 1.3 Possible solution for climate change and rising energy cost | 3 |
| 1.4 Motivation of work | 4 |
| 1.5 Evolution of Electric Vehicle | 4 |
| 1.6 Electric Scooter Drawbacks | 5 |
| 1.7 Thesis Objectives | 6 |
| 1.8 Organization of thesis | 6 |
| 2. REVIEW OF LITERATURE | 8-20 |
| 2.1 Electric Vehicle in Indian scenario | 8 |
| 2.2 Electric and Hybrid Electric Scooter | 9 |
| 2.2.1 Electric scooter | 9 |
| 2.2.2 Hybrid Electric Scooter | 11 |
| 2.3 Battery of Electric Vehicles | 13 |

| | | |
|-----------|---|--------------|
| 2.3.1 | Lead-Acid Batteries | 13 |
| 2.3.2 | Nickel-Metal Hydride Batteries | 14 |
| 2.3.3 | Lithium-Ion Batteries | 15 |
| 2.4 | Battery Cooling System Design and Analysis | 15 |
| 2.5 | Impact of Electric Vehicle | 17 |
| 2.6 | Case study | 18 |
| 2.7 | Summary of literature review | 19 |
| 2.8 | Research gaps | 19 |
| 3. | MATERIALS AND METHODS | 21-40 |
| 3.1 | Introduction | 21 |
| 3.2 | Selection of scooter | 21 |
| 3.3 | Selection of Motor | 22 |
| 3.4 | Selection of battery pack | 23 |
| 3.4.1 | Battery pack chemistry | 23 |
| 3.4.2 | Selection of battery pack | 24 |
| 3.5 | Conversion of an old scooter to Hybrid Electric Scooter | 26 |
| 3.6 | Power train configuration of Hybrid Electric Scooter | 29 |
| 3.7 | Battery charging methods | 30 |
| 3.7.1 | Plug in charger | 30 |
| 3.7.2 | By engine power | 30 |
| 3.7.3 | By regenerative braking | 31 |
| 3.8 | Testing the Hybrid Electric Scooter | 31 |
| 3.9 | Heat generation in battery | 33 |
| 3.10 | Steady State Thermal analysis of battery cell | 34 |
| 3.11 | Convection heat transfer on cell surface | 36 |
| 3.12 | CFD analysis of battery cooling | 36 |

| | | |
|-----------|--|--------------|
| 4. | RESULTS AND DISCUSSIONS | 41-60 |
| 4.1 | Introduction | 41 |
| 4.2 | Motor power | 41 |
| 4.3 | Li-ion battery chemistry | 42 |
| 4.4 | Battery pack capacity | 44 |
| 4.5 | Converted Hybrid Electric Scooter | 45 |
| 4.6 | Performance of Hybrid Electric Scooter | 47 |
| | 4.6.1 Driving performance | 47 |
| | 4.6.2 Performance of battery during charging and discharging | 49 |
| 4.7 | Battery heat generation | 51 |
| 4.8 | Convection heat transfer | 51 |
| 4.9 | CFD simulation | 53 |
| 5. | CONCLUSIONS AND FUTURE SCOPE | 61-63 |
| 5.1 | Conclusions | 61 |
| 5.2 | Future Scope | 63 |
| | REFERENCES | 64-68 |
| | ABSTRACT (ENGLISH) | 69 |
| | ABSTRACT (सारांश) | 70 |
| | LIST OF PUBLICATION | 71 |

LIST OF TABLES

| Table No. | Title | Page No. |
|------------------|--|-----------------|
| 1.1 | Comparison of electric and petrol fueled scooter | 4 |
| 3.1 | Specification of selected scooter | 21 |
| 4.1 | Cell types and relative advantage and disadvantage | 44 |
| 4.2 | Top speed of vehicle w.r.t. motor power | 45 |
| 4.3 | Test characteristics | 47 |
| 4.4 | Test characteristics for battery temperature | 54 |
| 4.5 | Boundary conditions | 54 |

LIST OF FIGURES

| Fig. No. | Title | Page No. |
|-----------------|---|-----------------|
| 1.1 | Increase in petrol prices in recent years | 3 |
| 1.2 | Fire in electric scooter on Indian roads | 6 |
| 2.1 | Power flow in Electric scooter | 10 |
| 2.2 | Power flow and control system of Hybrid Electric Scooter | 11 |
| 2.3 | Power flow of plug-in Hybrid Electric Scooter | 12 |
| 2.4 | Market share of types of batteries | 13 |
| 3.1 | CAD model with dimension of 18650 li-ion cell | 25 |
| 3.2 | CAD model of Li-ion cells arrangement in Battery pack | 26 |
| 3.3 | Sketch of Hybrid Electric Scooter | 26 |
| 3.4 | In wheel hub BLDC motor placed in Hybrid Electric Scooter | 27 |
| 3.5 | Battery pack placed in the boot of Hybrid Electric Scooter | 27 |
| 3.6 | Controller placed at the front panel of Hybrid Electric Scooter | 28 |
| 3.7 | Throttle placed at the left hand grip side of Hybrid Electric Scooter | 28 |
| 3.8 | Voltage display placed on console of Hybrid Electric Scooter | 29 |
| 3.9 | Power-train configuration of Hybrid Electric Scooter | 30 |
| 3.10 | Regenerative energy flow direction | 31 |
| 3.11 | Alternator/motor controller | 31 |
| 3.12 | Using temperature gun to measure battery temperature | 32 |
| 3.13 | Speed and range tracking on Zeopoxa application | 33 |

| | | |
|------|---|----|
| 3.14 | Steady state thermal methodology | 35 |
| 3.15 | Meshed model of cell used in Ansys | 35 |
| 3.16 | Meshed model of cells inside pack | 37 |
| 3.17 | Meshed model of battery pack | 37 |
| 3.18 | Air flow inside battery pack on cells surface | 39 |
| 3.19 | Air flow on walls of battery pack | 39 |
| 3.20 | CFD Simulation methodology | 40 |
| 4.1 | Power of motor w.r.t. vehicle speed | 42 |
| 4.2 | Comparison of different types of Li-ion battery used for EVs | 43 |
| 4.3 | Battery pack capacity w.r.t. vehicle speed for 80km range | 45 |
| 4.4 | Photograph of HES at DME (Pic 1) | 46 |
| 4.5 | Photograph of HES at DME (Pic 2) | 46 |
| 4.6 | Temperature comparison of battery, motor and vehicle body with average speed of HES | 48 |
| 4.7 | The variation in temperature of battery and motor against the distance travelled by vehicle | 49 |
| 4.8 | Characteristics for drain in battery voltage vs distance travelled by vehicle | 49 |
| 4.9 | Increase in Battery Voltage w.r.t. charging time | 50 |
| 4.10 | Temperature Variation of Battery w.r.t. time during charging | 50 |
| 4.11 | Heat generation in battery w.r.t. current drawn from battery by motor | 51 |
| 4.12 | Increase in temperature in battery w.r.t. Joule heat | 52 |

| | | |
|------|---|----|
| 4.13 | Increase in temperature in battery w.r.t. speed of vehicle | 52 |
| 4.14 | The heat distribution on cell surface | 53 |
| 4.15 | The temperature volume rendering of air flow inside enclosure | 55 |
| 4.16 | The Velocity streamlines distribution of airflow inside enclosure | 55 |
| 4.17 | Temperature volume rendering comparison for battery cooling at different inlet air speed | 56 |
| 4.18 | Velocity streamlines comparison for battery cooling at different inlet air speed | 57 |
| 4.19 | Effects of cooling on cells surface with inlet air flow at different speed of vehicle | 58 |
| 4.20 | Effect of cooling on battery pack surface with inlet air flow at different speed of vehicle | 59 |

LIST OF ABBREVIATIONS

| | | |
|-----------------|---|-----------------------------------|
| EV | - | Electric Vehicle |
| HES | - | Hybrid Electric Scooter |
| CO ₂ | - | Carbon Dioxide |
| NO _x | - | Nitrogen Oxide |
| CAD | - | Computer Aided Design |
| CFD | - | Computational Fluid Dynamics |
| ICE | - | Internal Combustion Engine |
| PHES | - | Plug-in Hybrid Electric Scooter |
| BES | - | Battery Electric Scooter |
| DC | - | Direct Current |
| BLDC | - | Brushless Direct Current |
| BTMS | - | Battery Thermal Management System |
| HEV | - | Hybrid Electric Vehicle |
| PCM | - | Phase Change Materials |
| SOC | - | State Of Charge |
| RUL | - | Remaining Useful Life |
| PHEV | - | Plug-in Hybrid Electric Vehicle |
| Li-ion | - | Lithium Ion |
| MILP | - | Mixed Integer Linear Programming |
| BDC | - | Brushed Direct Current |
| AC | - | Alternating Current |

| | | |
|--------|---|--------------------------------------|
| CVT | - | Continuously Variable Transmission |
| GPS | - | Global Positioning System |
| w.r.t. | - | With Respect To |
| V | - | Volt |
| A | - | Ampere |
| rpm | - | Revolutions Per Minute |
| DME | - | Department of Mechanical Engineering |
| Temp | - | Temperature |

INTRODUCTION

This chapter introduces the current issues with the transportation system, evolution of electric vehicle, solution of rising energy cost, electric scooter drawbacks, and a thesis organization.

1.1 General

The industrial revolution brought forth a great deal in terms of technology, society, and service provision, but it also brought about a great deal of negative outcomes, including environmental pollution and the production of hazardous gases that could prove dangerous to the public's health. Without a doubt, contaminants on a massive level are regarded as a serious public health challenge at the international level. This major concern has to do with lifestyle decisions as well as economic, social, legal, and legal issues. The industrial revolution was immensely successful in terms of technology, society, and the provision of many services, but it also insured the manufacture of considerable amounts of components that cause air pollution and are hazardous to public health. Without any question, contaminants are a complicated global public health issue. This important matter has a bearing on social, economic, legal, and lifestyle decisions.

Two negative effects of road traffic include pollution and a degradation in air quality. Motor vehicle exhaust emissions from fossil fuel and oil-powered engines are the main air pollution sources. Among the pollutants released by motor vehicles are carbon monoxide (CO), carbon dioxide (CO₂), nitrogen oxide (NO_x) in the forms of nitric oxide (NO) and nitrogen dioxide (NO₂), hydrocarbons (HC), and sulphur oxides (SO_x) in the forms of sulphur dioxide (SO₂) and sulphur trioxide (SO₃) (PM10). These cars release harmful gases that over time may have a negative impact on people's health.

According to traffic research, motorist vehicles are the primary source of the greatest amount of carbon monoxide in the atmosphere, and when nitrogen oxide and Sulphur in the air are taken into account, trucks are the primary source of these pollutants. Air pollution is a problem in our day and age since it not only contributes to

climate change but also has a detrimental impact on public and individual health by raising the rate of illness and death in society each year.

1.2 Current issues with the transportation system

1.2.1 Environment and climate change issue

Regardless of whether it is the North or South Pole, the entire earth is gradually heating up. The average surface temperature has increased by more than 1.6 °F (about 0.9°C) since 1906, and in sensitive polar regions, this rise in temperature is accelerating. The results and effects of this are currently being seen in the shrinking water bodies and melting glaciers that are posing problems for aquatic life and altering weather patterns (source: council.science).

Many people are unable to distinguish between global warming and climate change, although scientists define the latter as the complex processes that are currently adversely influencing the weather and the climate system. In addition to rising mean temperatures, major weather events, the relocation of wildlife creatures and their habitats, rising sea levels, and numerous other effects are all part of the climate change. As a result of humanity continuously releasing greenhouse gases into the atmosphere, all the changes outlined are taking place.

Private vehicles, of which scooters make up the majority, are to blame for more than half of the air pollution. Since electric scooters don't burn fuel, they are advantageous for enhancing air quality. The emissions produced during the manufacture of an electric scooter are frequently higher than most of those produced during the manufacture of a typical scooter. This has to do with producing lithium-ion batteries, which play a significant role in the electric vehicle sector. This transformation is bringing revolution, just like with cutting-edge technology.

The battery industry is constantly evolving, and a repurposing and recycling system is also currently being established. Used batteries are becoming a research issue for ways to make them more usable for new technologies and good power storage. According to current trends, batteries will be employed in common households to store our own energy one day. This type of research will aid in reducing the harmful effects of the environment.

1.2.2 Rising Energy Cost

The recent years survey of fuel prices shows a sharp increase in fuel prices, this increase is expected to be more in future it affects all the class of the families in India.

Fig 1.1 shows the increase in price of petrol in recent years.

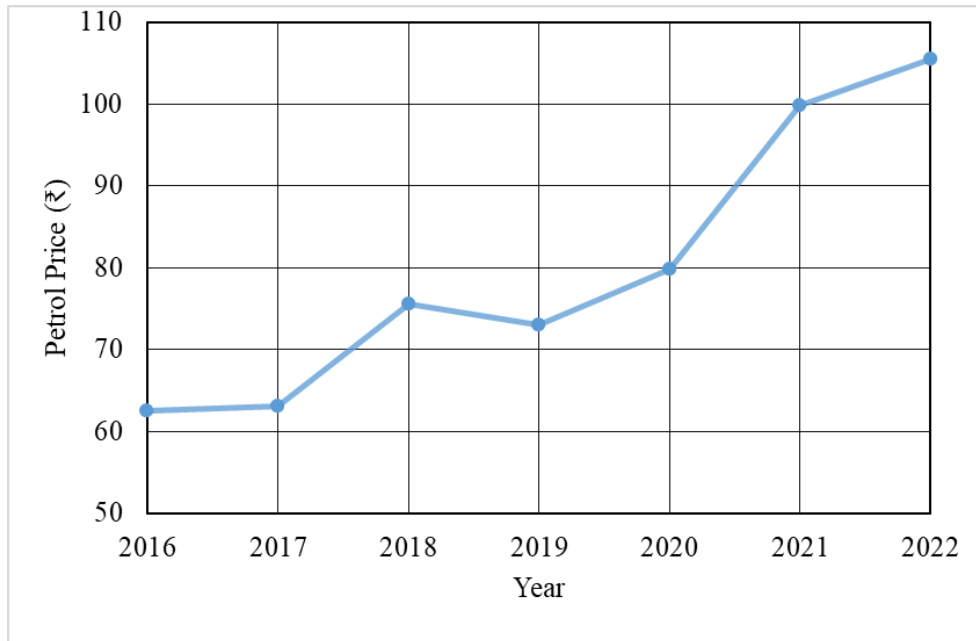

Fig 1.1 Increase in petrol prices in recent years (source : Mycarhelpline)

1.3 Possible solution for climate change and rising energy cost

The solution of rising energy cost is by developing certain vehicle which is powered by electric source that help in reducing tail pipe emissions and should be cheaper in running cost per km, in that case the electric vehicles are the most suitable one to replace the petrol vehicle with the same characteristics. **Table 1.1** shows the comparison of electric scooter and petrol fueled scooter.

Table 1.1 Comparison of electric and petrol fueled scooter

| Comparison Point | Electric powered scooter | Petrol fueled scooter |
|-------------------------|---------------------------------|------------------------------|
| CO ₂ Release | Nearly zero | Comparatively high |
| Fuel charges | Low priced | High priced |
| Maintenance | Cheap | Costly |
| No of moving parts | Few | Many |
| Friction losses | Low | High |
| Performance | Better | Good |
| Range | More range in the city | More range on highways |
| Purchase cost | Expensive | Cheaper than EV's |

1.4 Motivation of work

Seeing the circumstances of environment and rising fuel prices, it become difficult to operate petrol fuelled vehicle when we see the Indian scenario the number of vehicles are more as comparing with other countries so the need to acquire type of vehicle which depends more on electricity has become beneficial. To overcome these drawbacks of petrol fueled vehicle there is a need to develop HES which runs on battery and also on engine, which majorly solve the problem.

1.5 Evolution of Electric Vehicle

Electric vehicles have been around a lot longer than today's Tesla or the Tata Motors Nexon EV. In fact, electric cars appeared long before the internal-combustion sort in the 1830s, the Scotland's Robert Anderson, whose motorized carriage was built somewhere between 1832 and '39. Batteries were not rechargeable. Rechargeable batteries came in 1859, making the electric-car idea more feasible. In India in 1996, the first electric vehicle was a three-wheeler, invented by Scooter's India Pvt Ltd, and it was named VIKRAM SAFA. In 2000, BHEL developed an electric bus, which became popular. Electric vehicles began to exist in the 19th century. Earlier, they did not make space in the market because of their high cost, low speed, and short-range which causes the demand declined worldwide.

Automobile companies confront a major challenge: environmental sustainability. Regulations have been implemented as a consequence of this new approach to encourage users to switch to an environmental sustainable electric vehicle (EV) as opposed to a petrol engine. EVs serve in the sharp decrease of "greenhouse" gas emissions and fossil fuel dependence. Electric vehicles are regarded to be the best alternative for transportation in this regard because they release no exhaust gas, despite a number of technological obstacles.

Implementation of battery powered vehicles in the immediate future will reduce traditional fuel usage \$60 billion, resulting in a drop of 1 gigatonne of carbon emissions by the end of 2030. By the time India celebrates its 100th year of independence, the Indian automobile industry will have adopted a revolutionary solution of shared-connected electric mobility, resulting in a 100 percent electric vehicle (source: The Economic times, 12/05/2017)

When India celebrates its 100th year of independence, the Indian automobile industry, in partnership with the government, would have embraced an innovative shared-connected solution for electric mobility, resulting in a 100 percent pure electric vehicle. Electric vehicles (EVs) use distributed power to assist reduce CO₂ and NO_x emissions and so establish an energy-efficient transportation sector. Even though electric vehicles contribute to a cleaner environment, several obstacles remain. Battery degradation and charging infrastructure are the two most pressing issues that must be solved (sources: Energy & Etron).

1.6 Electric scooter drawbacks

In recent days many Electric Scooter (ES) are catching fire because of burning of battery due to high heat produce in battery. The investigation done on those ES clarifies the incident caused by fire in battery due to exceeding the level of heat in Li-ion battery as shown in **Fig 1.2**. The high temperature of battery not only increase the chances of fire but also decreases its efficiency and life span. The adverse effect of this level of increase in temperature can cause battery to blast which can be the worst case Scenario, that eventually effect the future customers & customers who are using ES.



Fig 1.2 Fire in Electric Scooter on Indian roads (source: News18, 30/09/2021)

1.7 Thesis Objective

To carry out the research work following objective are selected:

1. To convert conventional scooter into Hybrid Electric Scooter (HES).
2. To study the performance of developed Hybrid Electric Scooter.
3. To develop CAD model of battery for HES and CFD analysis for optimized cooling of battery for HES.

1.8 Organisation of Thesis

The present work involves of conversion of old scooter to Hybrid Electric Scooter (HES) by using electric motor, Li-ion battery, controller, etc., testing the performance and using computational fluid dynamics study on battery CAD model to access battery cooling strategy.

The thesis work is organized in the following manner as discussed below.

CHAPTER I presents an overview of the motivation towards present work, specifies problem statement, justification and objectives.

In CHAPTER II review of literature related to the work is presented, a brief overview and case study is presented about the research gaps identified.

In CHAPTER III materials and methodology adopted for the work to be done is presented. In this chapter the selection of scooter, motor, battery and a battery CAD

model is given and design, conversion and testing of Hybrid Electric Scooter(HES) unit is given. The performance evaluation and effectiveness of battery cooling is determined and its computational fluid dynamics study is presented in this chapter.

In CHAPTER IV results obtained from experiments and analysis work has been described. Effect of varying speed of HES on temperature of battery and motor and effect of increase in temperature of battery is discussed. The effect of varying air flow rate on battery temperature is also discussed. The study of cooling the battery inside and outside the battery case is also presented in this chapter.

In CHAPTER V finally the thesis has been concluded with the suggestions for the future work.

Furthermore, at last references related to literature used in the thesis along with a brief of the recommendations for the future work, summary, abstract of the thesis has been presented.

REVIEW OF LITERATURE

This chapter relates to the past work with a brief overview of previous researchers, developments and case study is presented about the research gaps identified.

2.1 Electrical Vehicle in Indian scenario

Electric vehicles are the vehicles those are fully or partially operated by using electric power. Electric vehicles are the replacement of conventional IC engine vehicles, to address the issue of pollution, depletion in natural resources etc. Benefits of EVs such as low noise, high efficiency make it a promising technology for sustainable transport sector in the future.

Electric vehicles (EV) have become more frequent in the transportation sector. The electric vehicle has the potential to replace internal combustion engine (ICE) in the near future, as the current trend indicates (Un-Noor et al., 2017 and Khurana et al., 2019). Since EVs can significantly reduce greenhouse gas emissions from the transportation sector, there may be enormous environmental benefits as well and also some disadvantage of their high price, lack of infrastructure for charging, and concern related to time and range. By 2030, the Indian government wants "only electric vehicles" on Indian roads.

There are numerous potentials for electric vehicles in India as stated by Jiby and Shirase (2019), the Indian auto industry is promoting alternative fuels by utilising cutting-edge technologies like battery-powered electric and hybrid vehicles, among others. The Indian government has supported new initiatives, incentives, and policies to grow the country's automobile industry.

One of the most important areas of research for industrialists in recent years has been the electrification of transportation. Dhinakaran et al. (2021) in his research, the advancements in electric vehicles and its personalization over time to this point have been made. Focuses is given on many batteries that are used in electric vehicles (EVs), as well as the advantages and disadvantages of the various driving systems and charging methods.

To improve the fuel efficiency vehicles can be modified to hybrid, plug-in hybrid, and electric vehicles as suggested by Goel et al. (2021) although these vehicles are more expensive to acquire than conventional vehicles but with over the course of their lifetime, customers, society, automakers, and policymakers generally benefit economically from their decreased petroleum consumption and greater production. The Indian government's recent measures and several incentives will support the country's move toward e-mobility.

The research by Chakraborty and Chakravarty (2023) employs a discrete choice survey methodology to collect responses from Indian residents. The findings derived from a random-parameter logit model analysis indicate that factors such as price, refueling time, availability of infrastructure, vehicle taxes, and fuel prices significantly influence the choice of two-wheelers. The results suggest that government policies, including price subsidies, preferential tax treatments, and infrastructure enhancements, should continue to be implemented to promote the adoption of electric two-wheelers in India. Furthermore, implementing differential pricing for petrol and electricity could further enhance the appeal of electric two-wheelers.

2.2 Electric and Hybrid Electric Scooter:

Electric scooter is type of electric vehicles which is fundamentally a two wheeled vehicle that contain battery to provide power to motor. Scooter is the most compact version of vehicles which makes them easy to use in traffic and rural areas. A major part of vehicles on road in India consists of Scooter, Electric scooter are the best implementation in order to spread awareness among peoples and reduce pollution as the reach of scooters are more than that of other vehicles. The electric scooter can be divided into two types, based on the level of power employed as a primary source:

- Electric scooter
- Hybrid electric scooter

2.2.1 Electric Scooter

Electric scooters(ES) are drove by a battery and an electric motor. To recharge

the battery, they use an external electrical charging port. Regenerative braking re-energizes the battery in ES. It has the benefit of a quick and smooth acceleration. It is an environmentally beneficial since it emits less CO₂. The block diagram of power flow in Electric scooter is shown in **Fig 2.1**.

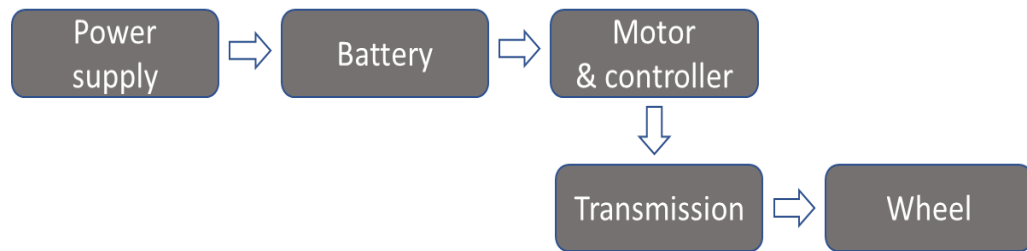

Fig 2.1 Power flow in Electric scooter (fig modified after Khande et al., 2020)

Due to the ongoing rise in gasoline prices, electrically charged vehicles are thought to be more affordable than regular vehicles. E-scooters are better suited for rural locations where there are insufficient gasoline stations as said by Khandar and Kosankar (2014) so that the residents can use electricity to charge the vehicle.

The design process and outcomes of E-scooter's motor had been provided, taking affordability into consideration production. Stator was the focal feature of the design preserving the core change for automated winding. Rotor properties and output features are vigour and effectiveness. The outcomes of design by Woo et al. (2017) satisfy those aside from the fact that cogging torque was significantly decreased. The study aid in the development of in wheel motor for an e-scooter.

The research by Racewicz et al. (2018) presents tests and the design of a lightweight, two-wheeled electric vehicle. The vehicle was propelled by a 3 kW brushless DC motor (BLDC). The vehicle is built on a sturdy steel bicycle frame and has pedals as an auxiliary driving source. The built-in E-top bike's speed during laboratory tests on the chassis dynamometer was almost 80 km/h. The wheel's measured torque and mechanical power were 3.6 kW and 132 Nm, respectively. 78 km/h is reached in less than 7 seconds of acceleration.

Pilot research carried out by Hardt and Bogenberger (2018) in Munich, Germany, by giving e-scooters to test subjects. Trip diaries showed that the cars were primarily used for commuting, recreational travel, and even local business excursions.

Roughly one out of every four participants took advantage of the opportunity to use the electric provided vehicles. According to trip data and survey responses, both commuting and business trips can be handled by e-scooters, while leisure excursions can be partially handled by the number of travellers.

In the research several voltage and current control systems for electric scooters' multi-pack batteries were comparison. Two control strategies based on energetic macroscopic representation and inversion-based control have specifically been introduced by Vo-duy et al. (2020). In the first system, each battery pack's two current controllers share the reference value generated by a single voltage controller. Meanwhile, in the second scheme, the voltage controller is handled by a specific battery pack.

2.2.2 Hybrid Electric Scooter

As the term describe hybrid which means integration of two power sources an internal combustion engine and an electric motor. The battery provides power to the drivetrain, when required and controlled by the controller allowing the engine to run more efficiently. The battery can be charged by the engine or by kinetic brake energy recovered during regenerative braking. Power flow and control system of Hybrid Electric Scooter(HES) is shown in **Fig 2.2**, and block diagram of power flow for plug-in Hybrid Electric scooter is shown in **Fig 2.3**.

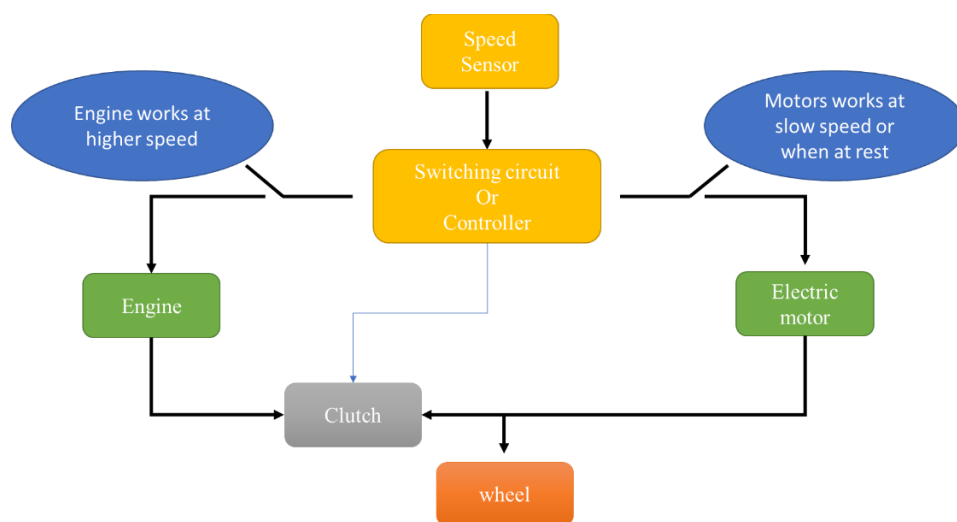

Fig 2.2 Power flow and control system of Hybrid Electric Scooter (source: Teambhp)

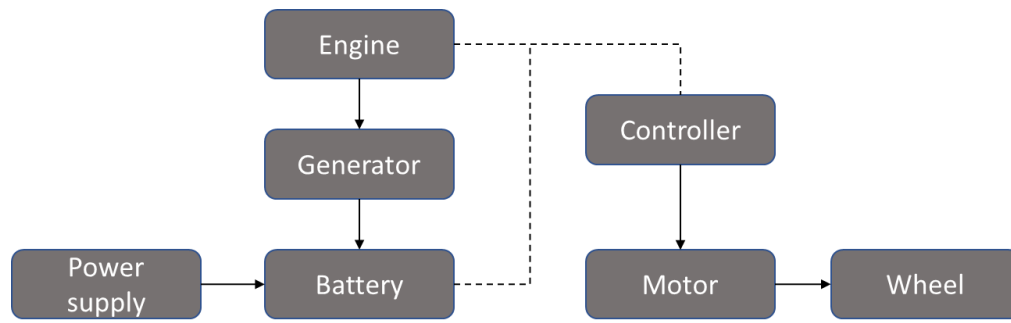

Fig 2.3 Power flow of plug-in Hybrid Electric Scooter (fig modified after Singh et al., 2019)

A parallel hybrid powertrain for a scooter that combines two planetary gear-trains into a split-power system (Sheu, 2008). The hybrid designs presented support six modes of operation. The goal is to use a simulation model to examine the performance of various hybrid powertrains in a hybrid electric scooter.

A design concept for an auxiliary power-mode Hybrid Electric Scooter (HES) as well as a dynamic simulation model for HES on drive cycles was created by Tseng et al. (2014). The engine as the primary source of torque and the electric motor as a backup source of torque. By connecting a servo motor and gearbox to the original CVT framework, the prototype was simple and cost-effective, the results shows improve fuel consumption rate up to 15%.

A series parallel Hybrid Electric Vehicle(HEV) model was created using Matlab/Simlunk includes a model of the tyre, an internal combustion engine, a battery, a DC/DC converter, a motor or generator's drive, a speed coupling device (a planetary gear mechanism), and a model of a torque coupler device (Yaohua et al., 2015) simulated the model to know the effectiveness. The simulated results helps to know how to use series parallel connection and when to use the motor and engine.

Light electric vehicles, such as electric scooters, had demonstrated significant promise for short-distance travel. Hybrid electric vehicles (HEVs) and electric vehicles (EVs) had proven effective in enhancing fuel efficiency. The research by Saju et al. (2022) focuses on optimizing power management techniques in parallel configurations of HEVs, highlighting their potential benefits in various vehicular applications, while addressing existing research gaps. The integration of hybrid

electric drive with efficient, low-cost solutions can lead to the development of environmentally friendly and marketable vehicles.

2.3 Battery for Electric vehicle:

Batteries are essential for all types of electric vehicles, Batteries for electric powered motors are characterised with the aid of using their extraordinarily high power to weight ratio, precise strength and strength density, smaller and lighter batteries are more ideal to use to the fact that they lessen the load of automobile and consequently enhance its performance.

Types of batteries commonly used are discussed as follows :-

2.3.1 Lead-Acid Batteries

Lead-acid batteries may be designed to be excessive strength and are inexpensive, safe, and reliable. However, low precise energy, terrible cold-temperature performance, and short calendar and lifecycle hinder their use. Advanced excessive-strength lead-acid batteries are being developed, however those batteries are handiest used in commercially to be had electric-pressure motors for ancillary loads. **Fig 2.4** shows all three types of batteries market share.

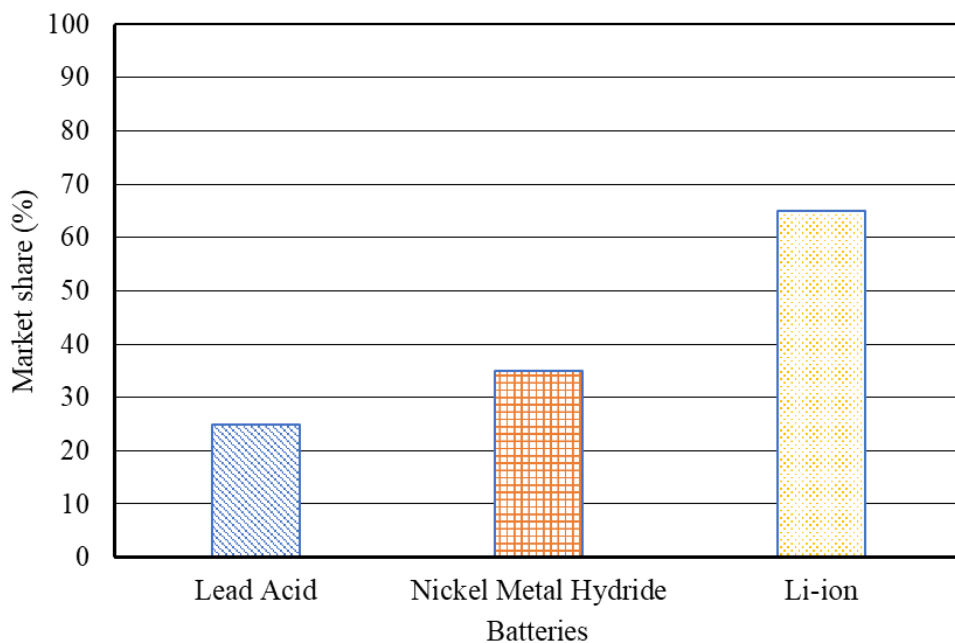

Fig 2.4 Market share of types of batteries (Source: research nester)

The dual prospective of li-ion battery performance and optimization and system feasibility, includes the thermal design regarding the different types of environments was presented by Shimamura et al. (2007). a simulation model combining electrode reaction and charge transport was constructed for analysing the battery performance, the result shows that charging electrode parameter make it more suitable for wide range of envisioned environmental vehicle. It is concluded that the li-ion battery are best suitable for the use in the electric vehicle.

The lead-acid battery represents the oldest rechargeable battery technology. Lead acid batteries can be found in a wide variety of applications including small scale power storage such as UPS systems, for automobiles (Enos and George 2014). While inexpensive when compared to competing battery technologies, lead-acid cells have a significantly lower power density and higher weight, along with a lower cycle life. A variety of commercially available systems use carbon-containing Pb-acid ultra batteries as their principal storage device.

2.3.2 Nickel-Metal Hydride Batteries

Nickel-steel hydride batteries, used mechanically in laptop and scientific equipment, offer affordable unique power and unique electricity capabilities. Nickel-steel hydride batteries have a far longer lifestyles cycle than lead-acid batteries and are secure and abuse tolerant. These batteries were broadly used in HEVs. The essential demanding situations with nickel-steel hydride batteries are their excessive cost, excessive self-discharge and warmth era at excessive temperatures, and the want to manipulate hydrogen loss.

The research by Tarabay and Karami (2015) demonstrates the fundamentals of Nickel Metal Hydride (Ni-MH) battery structure, components, and internal processes. Ni-MH batteries are industry leaders because they are ubiquitous in today's technology areas, powering everything from cellphones to hybrid electric vehicles. A brief examination of the chemical reactions inside Ni-MH batteries was presented, with a focus on its specifications and a mention of some of the most important applicable applications of such batteries in today's business. Furthermore, the electric circuit model of Ni-MH batteries must be discussed and considered to ensure that the reader retains all of the necessary basic information about Ni-MH batteries.

2.3.3 Lithium-Ion Batteries

Lithium-ion batteries are presently utilized in maximum transportable customer due to their excessive power in step with unit mass relative to other electric power garage systems. They even have a excessive power-to-weight ratio, excessive power efficiency, desirable excessive-temperature performance, and low self-discharge. Most of today's all-electric vehicles and HEVs use lithium-ion batteries. Research and development are ongoing to lessen their surprisingly excessive price, make bigger their beneficial life, and deal with protection issues in regard to overheating.

The Battery Thermal Management System (BTMSs) for EVs and Hybrid Electric Vehicle (HEVs) and PCM applications, the difficulties, possibilities, and prospects for EVs and HEVs are described by Malik et al. (2015). Key findings and conclusions between 2012 and 2013, EV sales increased annually in the US by more than 100%. At the moment, Li-ion batteries are the most popular and promising EV battery type. Battery prices are continuously falling across the board the cost of the battery pack utilised by top EV manufacturers decreased by 8% every year, reaching as little as US\$300 per kWh. Numerous studies are being conducted to address a number of problems with present battery technology, particularly with Li-ion batteries.

The primary research topics in lithium-ion batteries were outlined in the paper of Chen et al. (2019) including estimation of battery capacity, battery sorting, remaining battery life, battery circuit model, and SOC methods. A new approach and model for categorising retired batteries and estimating their SOC and RUL, lengthens the battery cycle life, reduces retired battery degradation, and improves retired battery consistency. Experiments will be conducted in the future to validate the efficacy of this approach.

2.4 Battery cooling systems:

As the number of electric vehicles increases on road their advantage and drawback are able to seen clearly one of the major drawback was catching fire in the battery pack due to thermal runaway which is mainly caused by increases in temperature in battery pack. This increase in temperature is mainly due to their compact structure and high energy discharge causing high heat and due to high environmental temperature as in India during summers, so to overcome the problem a cooling system needs to be developed.

The study by Cicconi et al. (2013) focuses on a PHEV Li-Ion battery cooling simulation. The thermal analysis is based on the single cell's physical parameters as well as experimental data. The methodology involves an analytical approach for determining the average heat generated by a single cell during operation. A thermal simulation of one cell and a CFD study of a battery module are the two aspects of the investigation. The analytical calculation of heat generated by electrochemical reactions is used in the battery thermal analysis.

The use of numerical simulation forced air cooling of a tightly packed battery box was explored to examine the impact of air cooling on temperature uniformity and hotspot mitigation under various flow pathways and airflow rates. The research by Meng et al. (2016) may lead to the following inferences: The magnitude of the temperature decreases gradually as cooling channel sizes increase, demonstrating that this is not the best way to reduce the maximum temperature; the maximum temperature and maximum temperature differential of the tightly packed battery box with 59 vents are obviously lower than they were with just 15 vents.

The cooling strategies for EV battery with forced air are calculated numerically in the paper by Lu et al. (2016) tells the size of cooling channel increases the temperature starts to drop in significant amount with the increase in number of vents increases the heat transfer decreases the maximum temperature. These models were then improved using a multi-objective optimization strategy to identify the best plan for an air-cooled battery module. The methodology will help know minimum and maximum temperature, temperature differential, and battery pack volume during the design of industrial battery packs. The air-cooling battery design in ANSYS.

The transient thermal behaviour of a Li-ion battery module had been investigated numerically in three dimensions in the current study by Jilte and Kumar (2018). The three-dimensional transient thermal, temperature regimes and flow field, a comprehensive analysis of localised hot spots had been presented. The local heat spots are confirmed when the temperature rises from the supplied cooling condition (22 °C) to the local temperature maximum of 26.37°C at some zones. The local temperature maxima zones are located in the centre of the module depth. Across the battery's depth, there are differences in the degree of flow separation. Despite the high discharge rate and low cooling air flow condition, the highest cell-to-cell temperature non-uniformity

in the examined BTMS is limited to 0.11°C , and the battery temperature is lower than 28°C .

The battery thermal management system(BTMS), including air cooling BTMS, liquid cooling BTMS and refrigerant direct cooling BTMS presented by Lu et al. (2020). The new battery thermal management system uses phase change material-based BTMS, heat pipe-based BTMS, and thermoelectric element-based BTMS. The ideal operating temperature range for lithium-ion batteries is rather limited because of their unique properties is between 20 and 40°C . Temperatures that are too high or low will have an adverse effect on the battery's performance and present a serious safety risk.

2.5 Impact of Electric Vehicle:

The impact of EVs in market with their promising effect on the environment shows the increase in sales of EVs in Indian automobile market in recent year as more advance and safer EVs are made still there is more to be worked on specially the range of EVs, their price and charging infrastructure.

Based on the empirical investigations in the literature, the range anxiety profile is a nonlinear function. Xu et al. (2012) created a compact model for the first time with a polynomial number of restrictions in order to reduce the cumulative range anxiety of worried travellers over the course of all trips. To do this, we clearly formulated the charging logic and path diversion behaviour in the model. an effective outer-approximation technique was suggested in order to find the underlying problem's - optimal solution.

The paper by Noel et al. (2019) explained that by building and expanding the Rhetoric of Reaction, creates a deeper understanding of range anxiety that would complement the technical and psychological frameworks. Range anxiety acts as a rhetorical device that is neither solely technical nor psychological.

The Battery Electric Vehicle (BEV) subsidies have very favourable effects on both accelerating economic growth and BEV adoption. Chen et al. (2020) findings also highlight the significance to take into account techniques for lowering non-tailpipe CO_2 emissions from car production and emissions from power generation if we want to fully benefit from the environmental advantages of BEV adoption.

The model of bi-objective nonlinear programming problem the range anxiety that drivers experience when travelling. Liu et al. (2020) measured the requirement of planned travels, suggested a specific function. An interactive branch and bound approach is used to solve the model after it is reformulated as a bi-objective MILP. They discover the model developed can plan the routes with high reliability and low risk of profit loss and accidents.

The study shows that if e-scooters weren't an option, roughly half of users would be walking or riding bicycles, and roughly one-third would be driving a personal vehicle. Therefore, e-scooters are probably impacting health in both positive and negative ways as researched by Glenn et al. (2020). This research may take the form of a health impact assessment.

The findings provided light on the ideal distance between nearby charging stations in order to reduce range anxiety. The findings by Pevec et al. (2020) can be used by business and government to increase consumer interest in EVs and encourage more people to buy them instead of conventional ICE vehicles, also find this to be very helpful because when developing appropriate scientific models, the ideal span between nearby charging stations must be taken into account.

To determine the effects of non-psychological markers on range anxiety, hourly weather data from more than 1.7 million EV charging and driving records were compared by Zhang et al. (2021). They come to the conclusion that the charging rate is inversely connected with the SOC, demonstrating that quick charging can significantly lessen range aversion. With an increase of charge piles, the impact of charging rate on range anxiety decreases. Fast charging might be more successful at easing anxiety in users who have severe range anxiety.

2.6 Case study

Looking into the article in THE TIMES OF INDIA dated: 28th September 2022 with a headline of “Govt pushes EV battery safety norms deadline to December”(source: Times Of India, 28/09/2022).

The article focused on the recent burning incidents of electric vehicle fire in April this year, cases of two wheelers such as Ola, Okinawa and PureEV catching fire were reported. It prompted the government to form a panel to examine. The

amendments include additional safety requirements related to the battery cells, design of battery pack and thermal propagation due to internal cell short circuits leading to a fire.

In return the Society of Manufacturers of Electric Vehicles (SMEV) said “There has been an acute shortage of good quality battery assemblers in India” and many more things, new safety measure for batteries will brought into effect in phase wise 1 December 2022 & 31 March 2023.

The step taken by Government of India will help in reducing the fire incidents and also increase in the efficiency of battery.

2.7 Summary of literature review

The literature overview portrays the design and modelling of an electric scooter, types of batteries and Electric vehicle EVs, impact of EVs, recent sales and accident, while the constructed electric scooter suggested an in-wheel motor design and the use of Li-ion battery packs for the electric scooter, which provide greater charge storage capacity and longer life than other batteries, and also developed guidelines. The BLDC motor is the most commonly used motor as it takes up less space. The Hybrid Electric Scooter (HES) has two different types of connecting systems: series and parallel. The researchers used CFD and thermal analysis to evaluate several aspects of cooling the battery with air, locating the heat spot and areas of excessive cooling. Researchers had also looked at the scope and limitations of electric vehicles, as India is a very large market for Electric Scooters (ES) and as the support from the government increase the sales pattern clearly seen a rise in sales graph, but the biggest barriers is the lack of charging infrastructure, less range causing range anxiety and the high cost of an EV scooters.

2.8 Research gaps

From the above literature survey research gaps are found as follows:

- Researchers had worked on design and fabrication on making electric scooter, but the detailed study on converted conventional scooter to electric hybrid scooter is still lacking.

- Researchers had worked on the different aspects of placing the motor and battery in the scooter, but more suitable place needs to be found out.
- Researchers analyzed the barriers of EV which needs to be overcome.
- The studied work shows the cooling technique of EV battery however the cooling approach needs an improvement.
- The studies show the CFD & thermal analysis of battery by air cooling result need more studies to become more effective.
- The studies show the safety standards imposed by government to make electric vehicles more safer this aspect needs to be studied.

MATERIALS AND METHODS

This chapter discuss the approach utilized for converting Hybrid Electric Scooter (HES) from selection of motor, battery to testing the performance and calculating battery heat generation as well as simulation of battery cooling method.

3.1 Introduction

An old scooter was taken into consideration and was converted into Hybrid Electric Scooter (HES) for reducing the environmental impact caused by burning of fossil fuel. Another factor taken into consideration was the cooling of battery of HES by making an air flow design air vent and making changes in placement of battery differently from other Electric Scooter (ES).

3.2 Selection of scooter

A convectional scooter was selected to convert it in Hybrid Electric Scooter (HES), the selection of conventional old scooter was to reduce the waste of those scooter which are to be discarded due to pollution under Bharat Stage Norms. The selected scooter was 2010 launched TVS Scooty Teenz which has a 2 stroke, single cylinder, forced air cooled SI Engine. The front and rear wheel has drum break, the size of wheel is 10 inch, the specifications of scooter are shown in **Table 3.1**.

Table 3.1 Specifications of selected scooter

| Items | Specification |
|---------------------|--------------------|
| Engine cc | 59.9 cc |
| Maximum Power | 3.5 Bhp @ 5500 rpm |
| Maximum Torque | 4.5 Nm @ 5000 rpm |
| Number of Cylinders | 1 |
| Transmission | Automatic |
| Kerb Weight | 82.00 kg |
| Fuel Tank Capacity | 4.5 L |

The scooter had a analogue speedometer and odometer, throttle and breaks at the handle, it has two person seating capacity. The top speed of scooty is around 50 kmph.

The suspension at the front was link type. So, in order to fulfil the power and range criteria the motor and battery of similar properties was selected.

3.3 Selection of Motor

The Electric scooter driven by electric motor which should be of sufficient capacity, similar to the power available at the wheel in case of engine driven scooter. The engine can run the vehicle at wide range of speed up to 100kmph. But, in the present study the vehicle speed was limited to 50kmph looking to the driving road conditions and crowd on road. Looking into the availability of motor for HES in the market there were mainly two types of motor used one is Brushed Direct Current Motor(BDC) and another one is Brushless Direct Current Motor(BLDC). Now looking into the characteristics, the BLDC motor is based on newer technologies that perform better than BDC motor with high efficiency, better power to weight ratio, produce less noise. The power required for motor is given by Eq. (3.1).

$$P = \tau \times \omega \quad (3.1)$$

Where, P = power (W), τ = torque (Nm) and ω = angular velocity (rad/s).

The angular velocity is given by Eq. (3.2) :-

$$\omega = \frac{v}{r} \quad (3.2)$$

Where, V = linear speed of vehicle (m/s), and r = radius of wheel (m)

Force is calculated using the coefficient of static friction value taken as 0.7 for dry road and normal reaction on the wheel in Eq.(3.3):-

$$F = \mu \times N \quad (3.3)$$

The overcoming torque is given by Eq. (3.4):-

$$\tau = F \times r \quad (3.4)$$

After, finding the value of angular momentum and torque we use it in Eq.(3.1) for finding power required for motor.

Where, F = force (kg)

N = normal force (N)

μ = coefficient of friction

V = linear speed (m/s)

r = radius of wheel (m)

τ = torque (Nm)

ω = angular momentum (rad/s)

P = power (W)

The power required for the motor is directly proportional to force applied on the wheel i.e., vehicle and rider weight. So, three constrained were made by varying the force applied on wheel in kg according to it calculation was done to determine the power for motor.

The motor selected for Hybrid Electric Scooter (HES) was a 750W in wheel hub BLDC motor having size which can fit the 10 inch wheel size of the selected scooty.

3.4 Selection of battery pack

The motor of Hybrid Electric Scooter (HES) which drives the scooter was power by a battery. Now, for the selection of battery for the driving range same as of old scooter. Two field were considered for the selection are:

3.4.1 Battery pack chemistry

For selection of battery for Hybrid Electric Scooter HES different types of battery was examined to be most suitable one to satisfy demand of their high power to weight ratio, high power efficiency, wide availability, and ability to recycle.

Comparing different types of Li-ion batteries considering several characteristics, with the larger area being more desirable is shown in chapter 4 section 4.3. The major factors considered are specific energy, specific power, safety, performance, life span, and cost. Specific energy represents how much energy a battery can hold per unit weight, which is directly proportional to driving range the driving range. Specific power is the ability to deliver high current on demand as during acceleration. Safety is one of the most

important aspects when choosing a battery because of the recent incidences. Performance refers the condition of the battery when used in extreme temperature conditions. Life Span refers cycle count and longevity. Cost presents the feasibility, with safety, and the 9–10-year warranty adding to this challenge. The detailed comparison of types of cell design is shown in section 4.

3.4.2 Selection of Battery pack

The battery pack capacity is defined as the total amount of electricity generated due to reactions in battery also the battery capacity demonstrates how much power the battery can produce from a fully charged state under specific discharge conditions. The selection of battery pack was done considering the characterises of battery to satisfy the motor requirements, range and life. The capacity of battery pack was decided using the Equations given below.

The battery pack capacity is given by Eq. (3.5):-

$$P_b = P \times \text{travel factor} \quad (3.5)$$

Where, P = power (W)

$$P_b = \text{battery power (Wh)}$$

Finding the current drawn by motor by Eq. (3.6):-

$$I = \frac{P_m}{v} \quad (3.6)$$

Now, considering the current losses during acceleration as 10%

$$I = I \times 0.90 \quad (3.7)$$

Finding the power required by the motor to run at desired top speed by Eq. (3.8):-

$$P = v \times I \quad (3.8)$$

After finding power, for designing the battery pack for certain km range we require travel factor which is given by Eq. (3.9):-

$$\text{Travel factor} = \frac{\text{total range (km)}}{\text{total speed (kmph)}} \quad (3.9)$$

After finding the power and travel factor, we use it in Eq. (3.4):

Also, considering the charging and discharging efficiency is about 85-93%. Then considering efficiency 85%, the battery pack capacity is given by Eq. (3.10).

$$\text{Battery pack capacity} = \frac{P_b}{0.85} \quad (3.10)$$

Where, P_m = motor power (W)

V = motor voltage (v)

I = current (Ah)

As the Eq. 3.10 the battery pack capacity is directly related with power of motor and speed on which the consideration was done. A definite power of motor has limited top speed. So, for the selection of battery pack the vehicle travelling range was assumed as 80 km.

The battery cell selected was 18650 Li-ion cell, **Fig 3.1** shows the dimension of 18650 Li-ion cell, the selected cell had $\text{Ø}18\text{mm}$ diameter and 65mm height and a CAD model was made on Solidworks.

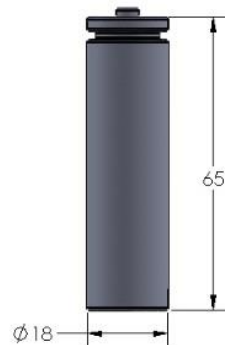

Fig 3.1 CAD model with dimension of 18650 li-ion cell

The battery pack made had a capacity of 20 Ah and 48V which was made with arrangement of cells 13nos in series and 12nos in parallel connection making it a pack of 156 cells shown in **Fig 3.2** with a battery pack of dimension 275x245x100mm. The battery operates between 53v to 43v.

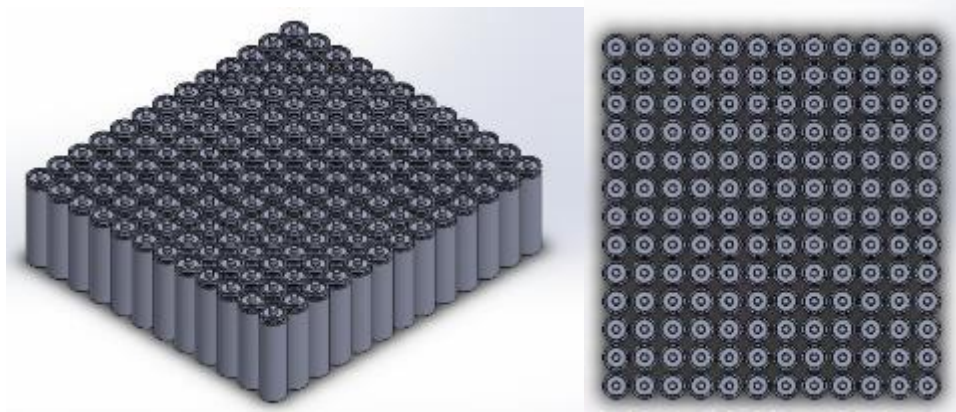

Fig 3.2 CAD model of Li-ion cells arrangement in Battery pack

3.5 Conversion of an old scooter to Hybrid Electric Scooter

The selected Petrol fuelled scooter as described in section 3.2 was converted into Hybrid Electric Scooter (HES) for reducing the environmental impact caused by conventional internal combustion engine. A sketch of HES is shown in **Fig 3.3**.

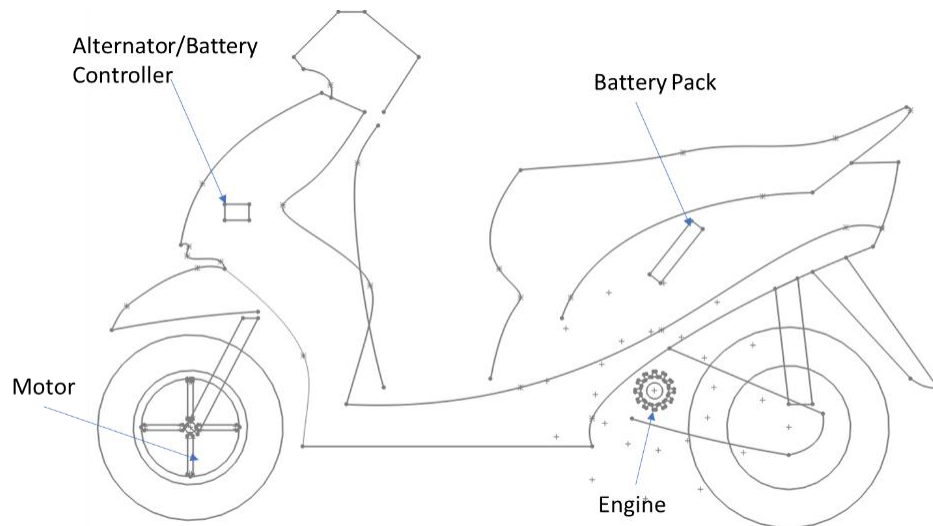

Fig 3.3 Sketch of Hybrid Electric Scooter

The BLDC motor was attached at the front wheel which drives the scooter on electric mode, the motor was placed with few arrangements such as changing the wheel with in wheel hub motor and removing the old front link type suspension by adding a new damper suspension as shown in **Fig 3.4**.



Fig 3.4 In wheel hub BLDC motor placed on Hybrid Electric Scooter

The battery through which power transfers to the motor was placed in the boot of the scooter safely as shown in **Fig 3.5**, The battery was also equipped with a Battery Management System (BMS) which ensures automatic switching off the current supply to the motor from the battery if battery temperature exceeds the safe operation limit. This safety precaution is for protection against overheating of battery and prevention of fire. which is controlled by the controller to take care of depth of discharge factor and BMS.



Fig 3.5 Battery pack placed in the boot of Hybrid Electric Scooter

The motor also works as an alternator which re-charges the battery during re-generation and during plug in charging mode. This was achieved with the help of an alternator/motor controller. The most optimum placement of this controller was at the front panel of the scooter as shown in **Fig 3.6**.



Fig 3.6 Controller placed at the front panel of Hybrid Electric Scooter

The throttle for the battery was at the left-hand grip side of the scooter handle. Through this throttle, the amount of current to be sent to the motor is controlled, the placement of controller is shown in **Fig 3.7**. When the load on the scooter is increased, for extra power, it can be driven on Hybrid Mode, i.e., power will be delivered by both, the internal combustion engine as well as the electric motor.



Fig 3.7 Throttle placed at the left hand grip side of Hybrid Electric Scooter

To show the voltage of battery an addition display was attached on the console which continuously displays the voltage left in the battery, the screen is a three digit display, the placement of display is shown in **Fig 3.8**.



Fig 3.8 Voltage display placed on console of Hybrid Electric Scooter

3.6 Power train configuration of Hybrid Electric Scooter

The power-train used in Hybrid Electric Scooter (HES) where the battery is used to power the BLDC motor of HES, engine is used as an alternative to power the rear wheel in case when there is no electricity and in emergency situations of no voltage left in battery. The engine power also used to charge the battery through regeneration of electric energy when the vehicle is drive in the internal combustion engine mode. The HES can be driven by both IC engine & Electric motor, the power train configuration of HES is shown in **Fig 3.9**.

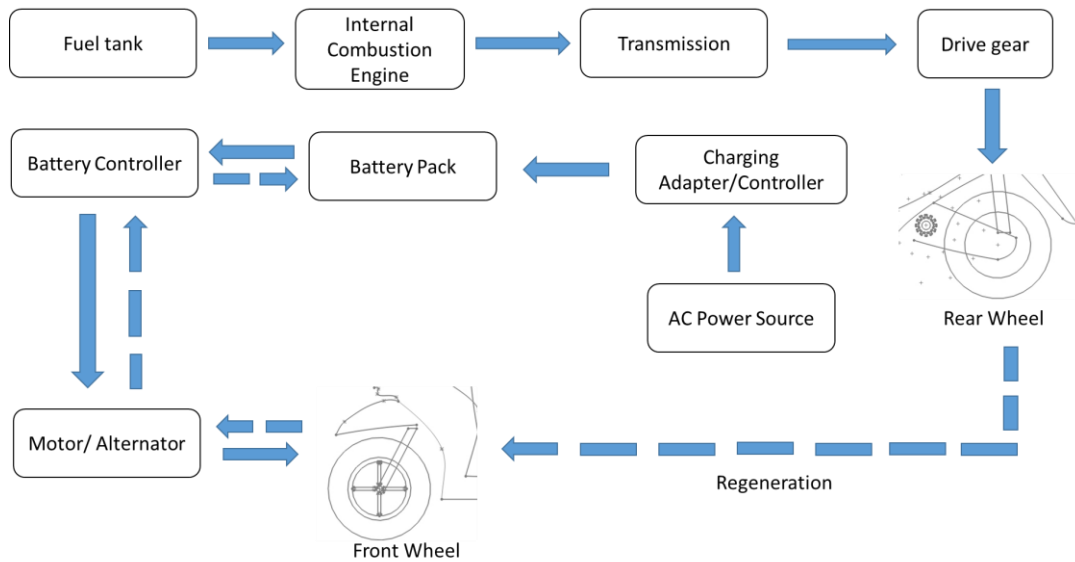

Fig 3.9 Power-train configuration of Hybrid Electric Scooter

3.7 Battery charging Methods

The battery is charged by 3 methods:

- Plug in charger
- By Engine power
- By regenerative braking.

3.7.1 Plug in charger :-

An AC to DC 220 V, 50Hz charger which can be plug in in any & regular electric socket charges the battery in rest position of scooter.

3.7.2 By Engine Power:-

The transmission of engine power from engine to the rear wheel takes place with the help of Continuously Variable Transmission (CVT) system. Unlike a conventional transmission system, the CVT does not make use of gears. Instead, it has two pulleys, whose diameters are variable and are connected by a belt or a chain. One end is connected to the engine and the other one is linked to the wheel, where the power is delivered. The pulleys are movable and as they come closer to each other, the belt or the chain rides higher making the diameters of the pulleys larger and vice-versa.

When the scooter is being driven with engine power at the rear wheel, the front wheel also rotates due to which the alternator attached to the front wheel generates electricity,

hence the battery is re-charged. During braking and vehicle moving on down slop/hill, also recover the energy via battery charging through alternator attached to the front wheel.

3.7.3 By Regenerative braking :-

The Same BLDC mater which powers the HES is used to generate electricity at the time of deacceleration which also helps in stopping the HES increasing the life span of brake pad.

With the help of regenerative braking system, kinetic energy that would have otherwise been converted to heat is recovered and turned into electricity. In this system, when accelerating the engine propels the wheels, and when slowing down, the wheels propel the motor. Flow of energy from wheel to motor is shown in **Fig 3.10**. The picture of the alternator/motor controller is shown in **Fig 3.11**.

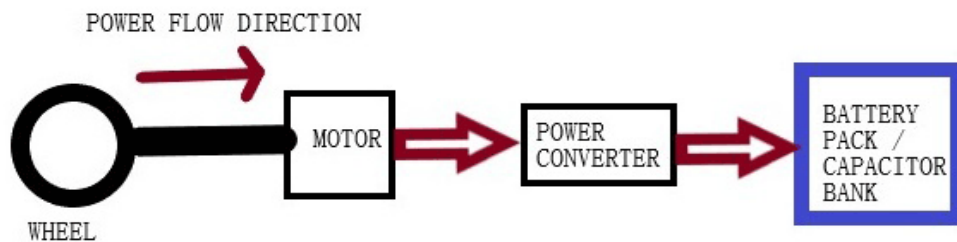

Fig 3.10 Regenerative energy flow direction



Fig 3.11 Alternator/motor controller

3.8 Testing the Hybrid Electric Scooter

The converted Hybrid Electric Scooter was tested at Maharana Pratap University of Agriculture and Technology, Udaipur premises on 17th September 2022,

the environmental temperature at the time of testing was 32.2°C. The instruments used while testing was Temperature gun and smart phone GPS with the Zeopoxa tracking application available on android play store.

The HES was fully charged before the testing. The criteria decided for testing was measuring the temperature of battery, motor, and scooter also measuring the distance travelled while varying the speed of a fully charged battery until it drain out. The test characteristics was noted for a duration of 10 minutes each. The surface temperature of single cell in the battery pack and on the battery pack surface was measured using temperature gun shown in **Fig 3.12**, with temperature measuring range of -50°C to 750°C and least count of 0.01°C.



Fig 3.12 Using temperature gun to measure battery temperature

For tracking and measuring the range and speed of HES the smart phone GPS with the Zeopoxa tracking application the screen shot shown in **Fig 3.13** available on android play store was used for accurate measurement.

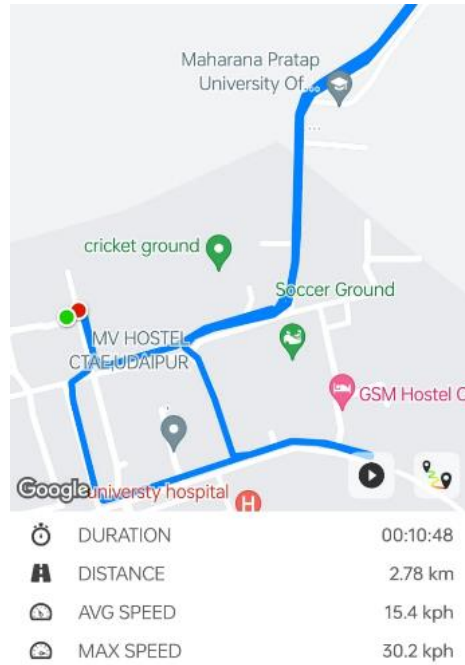

Fig 3.13 Speed and range tracking on Zeopoxa application

3.9 Heat generation in battery

The heat generated in the battery at the time of discharge with a certain C_{rate} due to enthalpy change and chemical reaction. When current flow in resistive component of cells it will produce Joule heat which will be released inside the cell which will ultimately result in increase in temperature of cell and hence battery pack.

Joule heating is considered as a parameter for heat generation in battery pack.

The joule heating Q in the cell is calculated using Eq.(3.11):-

$$Q = I_c^2 \times \Omega \quad (3.11)$$

Where, Q = Heat generation (W)

I_c = Cell current (A)

Ω = end resistance (Ohm)

The power, current and rated current of motor I_r is calculated using Eq. (3.12) and (3.13):-

$$P = V \times I_r \quad (3.12)$$

$$I_r = \frac{P}{V} \quad (3.13)$$

Now finding the charge rate C_{rate} using Eq. (3.14) and (3.15):-

$$C_{rate \text{ rated}} = \frac{I_r}{I_b} \quad (3.14)$$

$$C_{rate \text{ peak}} = \frac{I_p}{I_b} \quad (3.15)$$

Considering each cell capacity, the cell current is given by Eq.(3.16) :-

$$I_c = \text{each cell capacity} \times C_{rate} \quad (3.16)$$

After finding the cell current and considering the standard end resistance of cell we use it in Eq.(3.11).

Where, I_r = Rated motor current (A)

I_p = Peak motor current (A)

I_b = Battery pack current (A)

$C_{rate \text{ rated}}$ = Charge rate

$C_{rate \text{ peak}}$ = Charge rate

P = Motor power

V = Motor voltage

3.10 Steady State Thermal analysis of battery cell

To understand the heat flow on the cell surface the steady state thermal analysis was performed on the cell a CAD model of cell was made on Solidworks shown in section 3.4.2 was imported in Ansys 2021 R1 software. The value of heat flow was calculated by Joule heating factor in Watt in section 3.9.

The temperature distribution in the cell can be seen in Ansys software using steady state thermal, using steps shown in **Fig 3.14**.

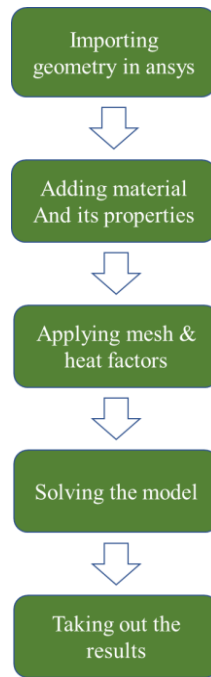

Fig 3.14 Steady state thermal methodology

A grid independent study was performed on the CAD model of cell in Ansys where no such deviation in results were noticed when meshing with fine and coarse mesh. So, to make solution fast coarse mesh of 0.005m mesh size with 8226 nodes and 4472 elements was used on the cell in Ansys as shown in **Fig 3.15**.

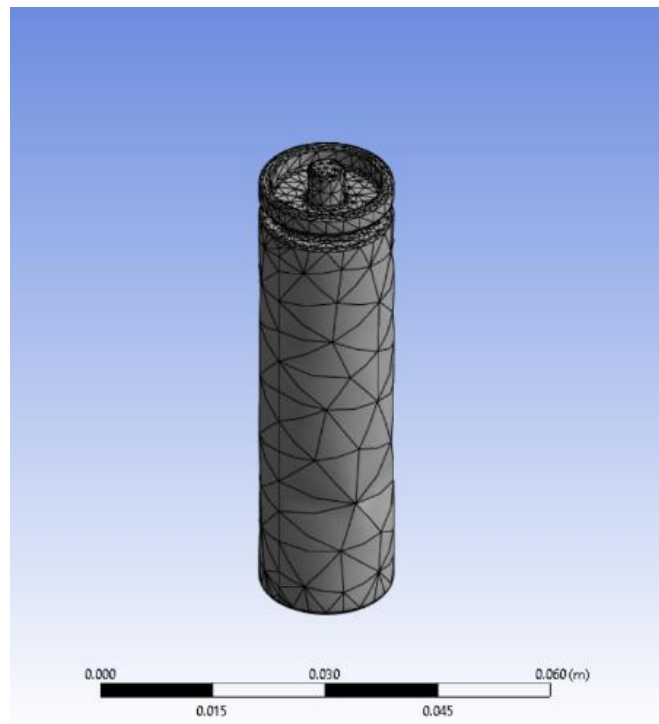

Fig 3.15 Meshed model of cell used in Ansys

3.11 Convection heat transfer on cell surface

The convection heat transfer helps to know the temperature with factors considering material heat transfer coefficient, heat, and initial temperature.

For finding the temperature on the cell surface convection heat transfer equation was used considering Joule heating results as discussed in section 3.9.

The convection heat transfer equation is given in Eq. (3.17) :-

$$Q = hA(T_s - T_f) \quad (3.17)$$

The value of Q is found using Eq. (3.11).

The temperature of cell is given by Eq. (3.18):-

$$T_s = \left(\frac{Q}{hA}\right) + T_f \quad (3.18)$$

Where, Q = Heat transfer (W)

h = Convection heat-transfer coefficient (W/m²K)

A = Exposed surface area (m²)

T_s = Surface Temperature (°C)

T_f = Fluid Temperature (°C)

3.12 CFD analysis of battery cooling

The rise of temperature in Li-ion battery causes thermal runaway that leads to fire in battery, the temperature at which thermal runaway occur and the battery catches fire is given by Tete et al. (2021) where the information provided by the study was that 60°C is the trigger warning for BMS and 80°C is the limit set by BMS because it is the critical temperature above that fire can be seen in the battery.

To get more precise results HES was tested again at Maharana Pratap University of Agriculture and Technology premises where the HES was fully charged and HES was made to run on its full speed, the environmental temperature at the time of testing was 32.2°C. The criteria decided for testing was measuring the temperature of battery and measuring the distance travelled with the speed. The test characteristics was noted

for a duration of 10 minutes each. The temperature was measured using temperature gun which had temperature measuring range of -50°C to 750°C and measuring accuracy of 50 feet away, for tracking and measuring the range and speed of HES the smart phone GPS was used for accurate measurement.

The CAD model of cell inside a battery pack was made on Ansys software with the dimension similar to the battery pack and cell arrangement, the meshing performed had a physical preference of CFD and solver preference for Fluent while meshing also a grid independent study was performed where the fine mesh of mesh size of 0.001m with 117636 nodes and 113344 elements on the cells inside pack shows a greater results and was selected but in case of battery pack there is no such variation in results so the coarse mesh of 0.003m size with 2392 nodes and 7477 elements was selected for faster processing, the meshing of the models are shown in **Fig 3.16** and **Fig 3.17**.

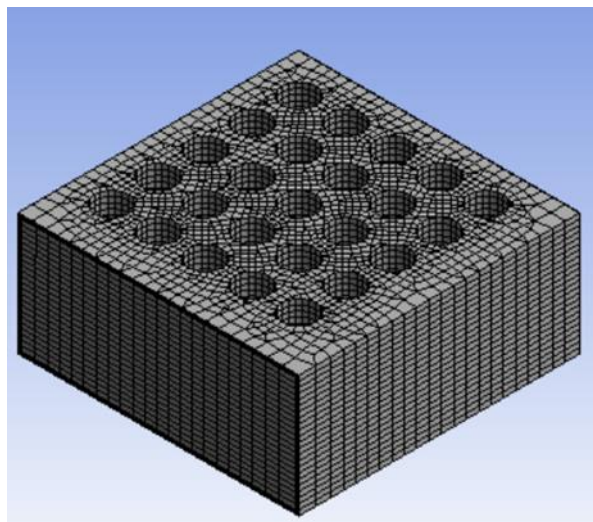

Fig 3.16 Meshed model of cells inside pack

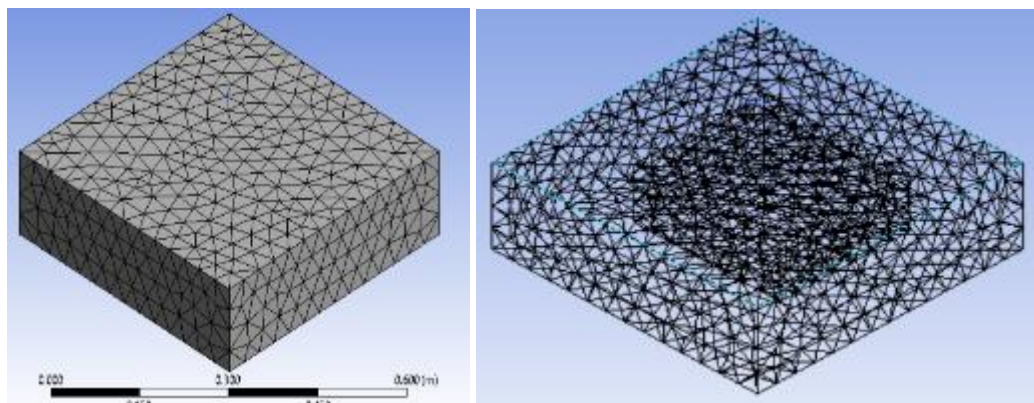

Fig 3.17 Meshed model of battery pack

Experimental Validation :

A surrogate model of cells and battery pack was developed. In order to validate the effectiveness of the present CFD method, the experimental results were compared by comparing the temperature of battery from experimental and numerical data. The compared data shows the difference in temperature of experimental and numerical data which was acceptable considering the experimental measuring of battery temperature was on the battery cell surface measured with temperature gun whereas the numerical data shows the temperature of the cell generated inside the cell. The platform created was consists of three parts, i.e., the air, the battery model, and the measured section.

In the system the equivalent heat source of battery cells was replaced with a temperature surface. Several iterations are performed to mutually validate the benchmark and optimized case. Twenty five surfaces was included in the system, with the identical spacings as 3 mm, an air inlet to supply the cooling air. Various inlet airflow speeds are considered.

When evaluating the cooling efficiency of battery, the flow field and the temperature field of the system should be obtained. Computational Fluid Dynamics (CFD) method is an effective way to calculate the flow field and the temperature field. In the present study, CFD method was introduced to evaluate the cell temperature difference. The Reynolds number referred to the inlet air speed was usually larger than 3000, so the status of the airflow in the model was turbulence flow.

For the air-cooled, the following boundary conditions were used. The inlet condition was the air flow inlet with constant temperature. The outlet condition was the pressure outlet. Non-slip conditions and the adiabatic conditions were imposed on the surrounding walls of the system. The assigned temperature on the surface was found using Eq. (3.18). The air inlet is shown in **Fig 3.18** and on the wall of battery pack shown in **Fig 3.19**.

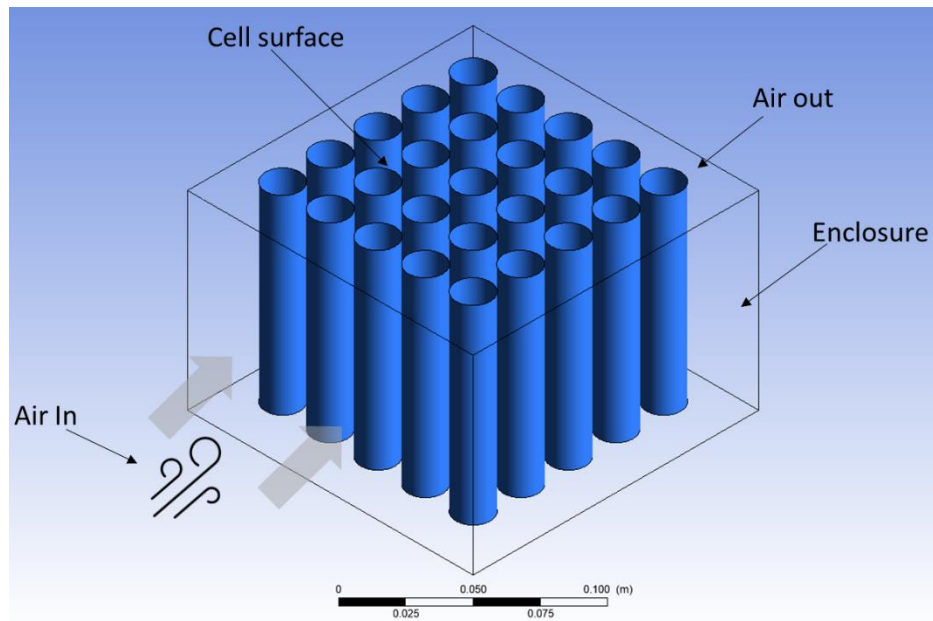

Fig 3.18 Air flow inside battery pack on cells surface

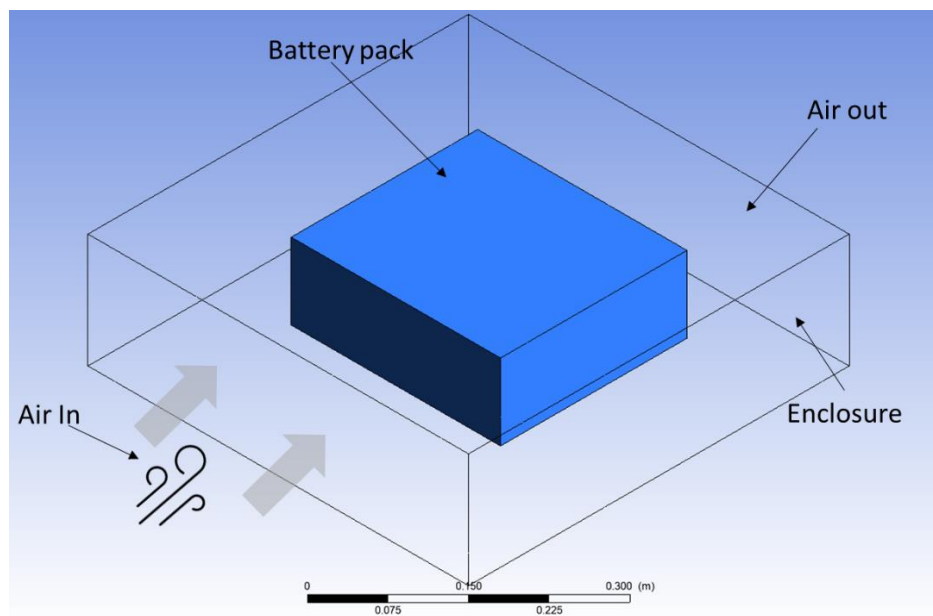

Fig 3.19 Air flow on walls of battery pack

The CFD simulation was performed in Ansys 2021 R1 fluent with methodology shown in **Fig 3.20**.

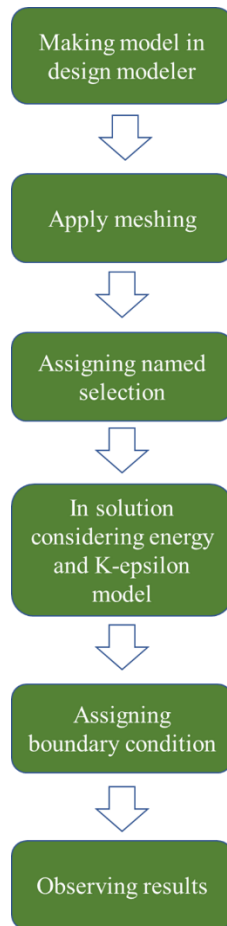

Fig 3.20 CFD Simulation methodology

RESULTS AND DISCUSSIONS

This chapter shows the results obtained from experiments and analysis work. Effect of varying speed of Hybrid Electric Scooter (HES) on temperature of battery and motor and effect of increase in temperature of battery is discussed. The study of cooling the battery inside and outside the battery case is also presented in this chapter.

4.1 Introduction

The results of testing and simulation of the suggested Hybrid Electric Scooter (HES) are presented in this chapter. The Li-ion battery is composed into six types according to battery chemistry after that battery capacity is selected then comes the selection of motor. Testing was done in real environment and results are plotted, battery cell steady state thermal analysis was performed and according to that the CFD simulation results are displayed in the following section.

4.2 Motor Power

The numerical calculation was performed to calculate the motor power, the major factor considered are previously discussed in chapter III under section 3.3. As the selection of motor will directly influence the performance of HES and vary with different type of speed and weight on the wheels.

The weight on wheels combining the driver and scooter weight used as a factor to plot the graph to clearly visualise the power of motor to be selected the graph is shown in **Fig 4.1**.

Weight 1: 120kg.

Weight 2: 150kg.

Weight 3: 170kg.

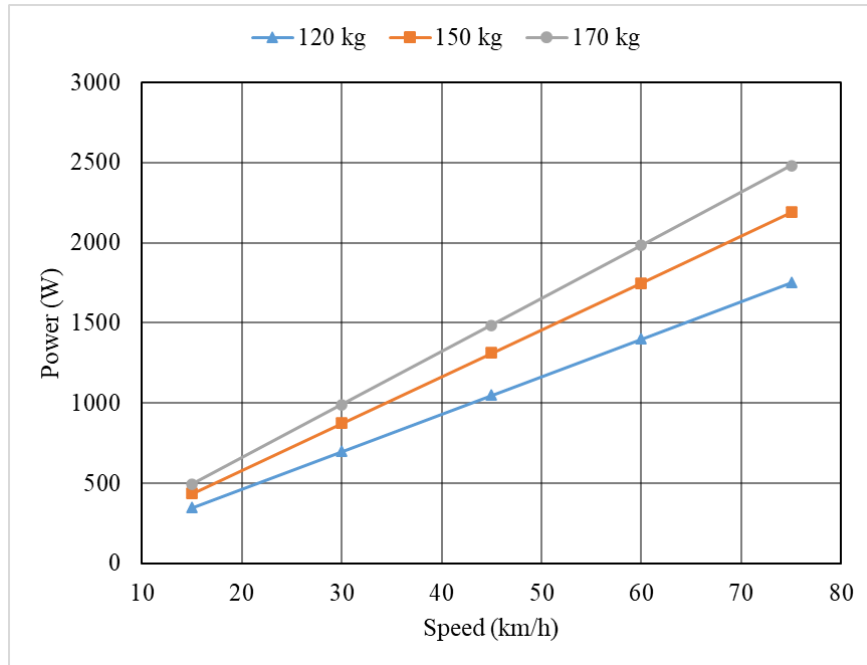

Fig 4.1 Power of motor w.r.t. vehicle speed

The calculated results suggest that for a certain weight on wheels the power of motor linearly increases to match the speed of vehicles, the summarized results shows high power motor is required to carry heavy weight at high speed.

4.3 Li-ion battery chemistry

As per the factor decided to find out the most suitable Li-ion chemistry battery the comparison of different type li-ion battery as per the research carried out by Miao et al. (2019) is shown in **Fig 4.2**.

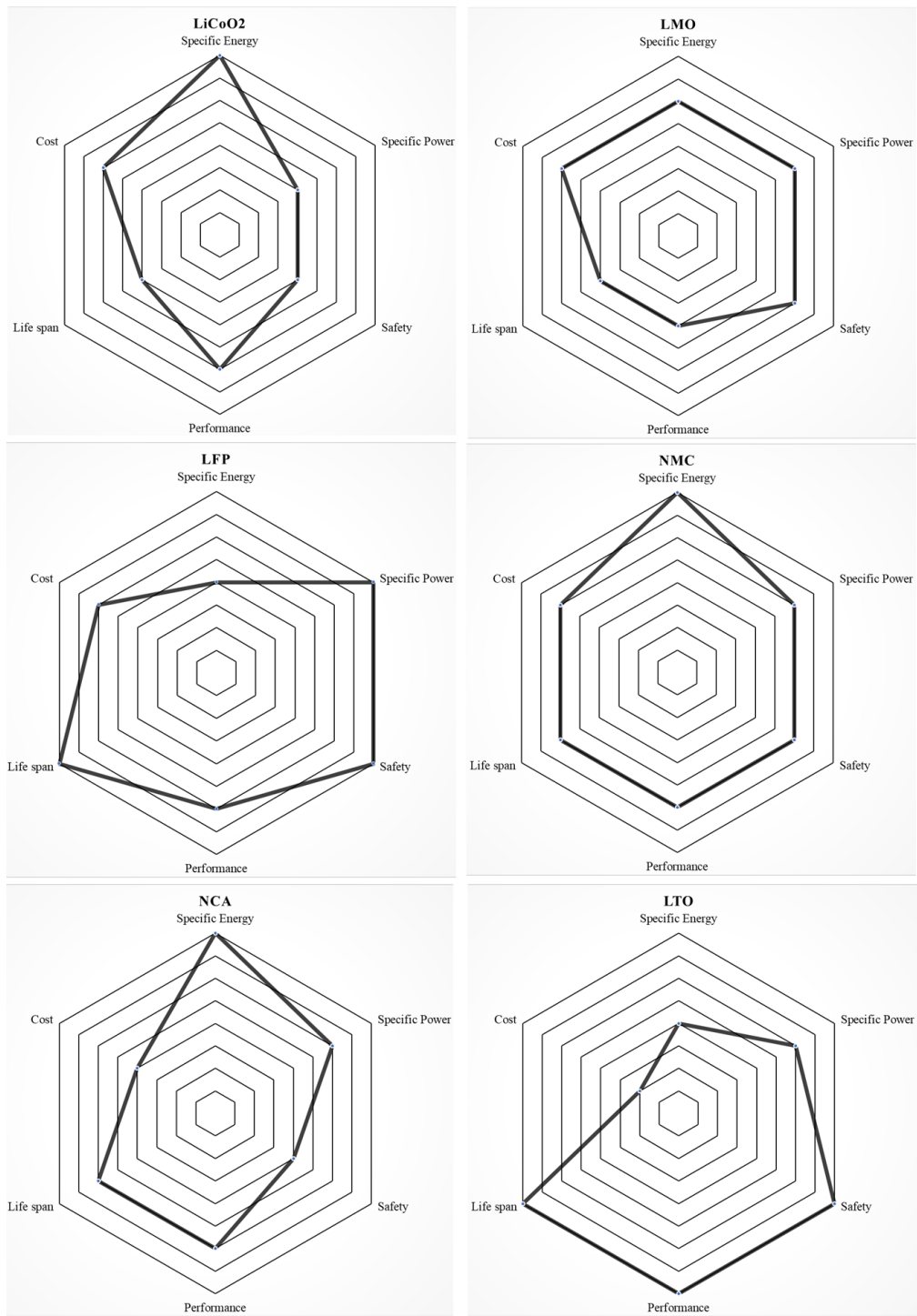

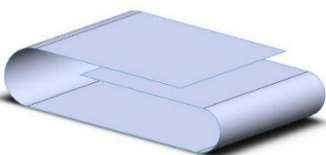



Fig 4.2 Comparison of different types of Li-ion battery used for EVs (modified from Ali et al., 2019, Miao et al., 2019 and Zhang et al., 2018)

The selection of cell is made with reference to advantages and disadvantages given in **Table 4.1**.

Table 4.1 Cell types and Relative advantage and disadvantage

| Shape | Cylindrical | Prismatic | Pouch |
|------------------------------|---|--|---|
| Diagram |  |  |  |
| Electrode Arrangement | Wound | Wound | Stacked |
| Advantage | Low cost, high production rate, high mechanical strength | Lighter in design, high packing efficiency, high energy density | High specific energy, moderate energy density |
| Disadvantage | Low energy capacity, low heat management | Prone to swelling | Less mechanical strength, low energy density, poor thermal management |

Considering all the factors NMC(Lithium Nickel Manganese Cobalt Oxide) battery was selected due to high specific energy, costing and easy availability. Considering the advantages and disadvantages of types of Li-ion batteries, the cylindrical cell was most suitable due to its low cost, high strength, and ease to make a battery pack is considered best for HES.

4.4 Battery pack capacity

The calculation of battery pack capacity for Hybrid Electric Scooter (HES) for a fixed range of 80km considering different power of motor, continuously working on their top speed.

The motor selected for different speeds are shown in **Table 4.2**.

Table 4.2 Top speed of vehicle w.r.t. motor power

| Motor Power (W) | Speed (Km/h) |
|-----------------|--------------|
| 750 | 30 |
| 1000 | 40 |
| 1200 | 50 |
| 1500 | 60 |
| 2000 | 70 |
| 3000 | 80 |

To identify the battery pack capacity for a range of 80km considering the top speed and motor power a graph been plotted between battery pack capacity and speed of vehicle shown in **Fig4.3**.

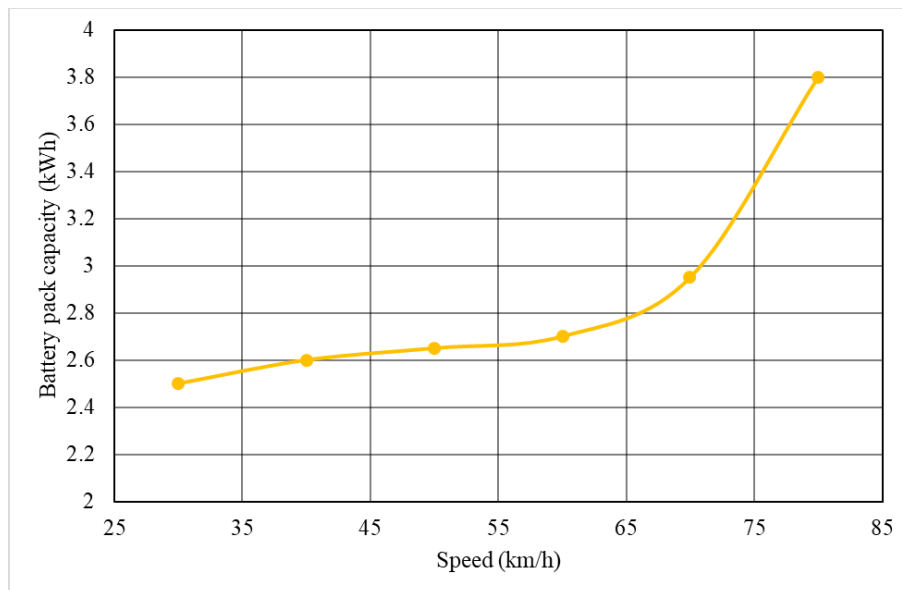

Fig 4.3 Battery pack capacity w.r.t. vehicle speed for 80 km range

The calculated results shows the capacity of battery pack depended on power of motor after that there is increase seen in battery pack capacity with speed of vehicle increases as calculated numerically, for 80km/h speed and 80km of driving range the capacity of battery pack calculated to be 3.8kWh.

4.5 Converted Hybrid Electric Scooter

A Hybrid Electric Scooter(HES) was made using conventional scooter as the base and the placement of battery, motor and controller are according to the

methodology. The power train of HES was also according to the block diagram in the methodology, the picture of converted HES can be seen in **Fig. 4.4** and**4.5**.



Fig 4.4 Photograph of Hybrid Electric Scooter at DME (Pic 1)



Fig 4.5 Photograph of Hybrid Electric Scooter at DME (Pic 2)

4.6 Performance of Hybrid Electric Scooter

4.6.1 Driving performance

Testing of HES was done to carry out the driving characteristics for knowing the discharge rate, speed, range, and temperature of different areas.

The test characteristics carried of the scooter on the electric mode in a single charge shown in **Table 4.3**.

Table 4.3 Test characteristics

| Sr. No. | Time interval (min) | Battery Temp. (°C) | Motor Temp. (°C) | Vehicle Body Temp. (°C) | Average Speed (km/hr) | Distance Travelled (km) | Battery Voltage (v) |
|---------|---------------------|--------------------|------------------|-------------------------|-----------------------|-------------------------|---------------------|
| 1 | 0 | 29.5 | 30.1 | 32.9 | - | 0 | 52.6 |
| 2 | 10:05 | 30.6 | 36.2 | 39.1 | 15.6 | 2.88 | 51.6 |
| 3 | 10:00 | 32.6 | 41.8 | 34.8 | 14.4 | 5.38 | 51.1 |
| 4 | 10:05 | 33.7 | 44.6 | 39.7 | 17.6 | 8.67 | 48.3 |
| 5 | 10:05 | 34.4 | 44.3 | 35.3 | 20.3 | 12.28 | 45.5 |
| 6 | 11:20 | 35.7 | 44.8 | 36.5 | 16 | 15.49 | 43.9 |

The road testing of vehicle was carried out at various speed and temperature of battery, motor and vehicle body was measured **Fig 4.6** shows the various temperature at different driving speed.

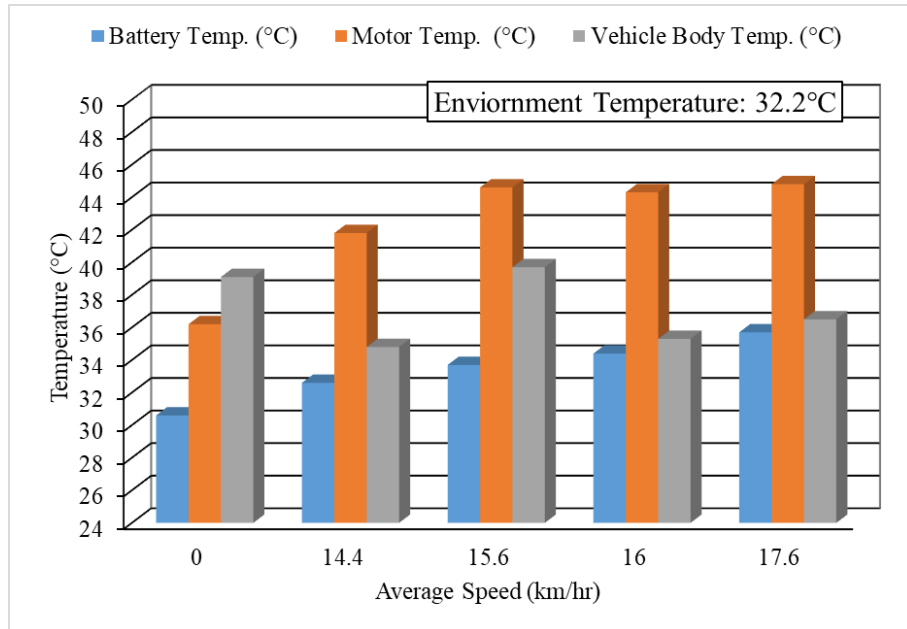

Fig 4.6 Temperature comparison of battery, motor and vehicle body with average speed of HES

The test results shows the temperature of motor and battery changes as the speed of vehicle increases, the battery temperature increases normally with the increases in vehicle speed which is not in case with motor and vehicle body temperature which is due to forced convection of air which works as a cooling effect on motor and vehicle body the fluctuation in temperature was been clearly seen.

The change in temperature of battery and motor with the distance travelled is shown in **Fig 4.7** where the environmental temperature was 32.2°C at time of testing. The test results shows the temperature of motor and battery increases with increase in running time and continuous acceleration, as 5km travelling distance the temperature of battery was 33°C and motor temperature was 42°C while at 15 km travelling distance the temperature of battery increases to 36°C and motor temperature is 45°C, the motor temperature doesn't rise more because of forced convection of air on motor increases with increase in speed and time.

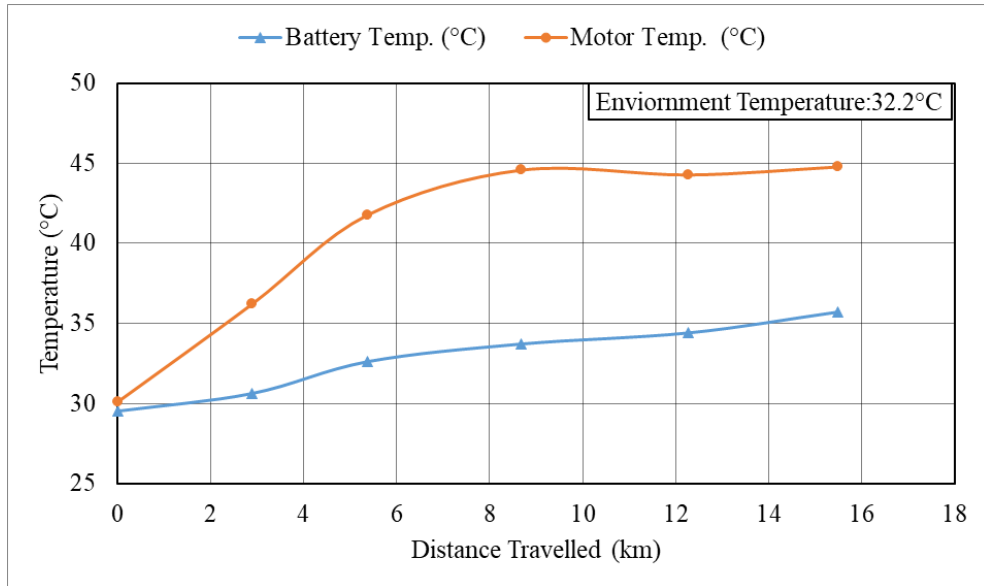

Fig 4.7 The variation in temperature of battery and motor against the distance travelled by vehicle

4.6.2 Performance of battery during charging and discharging

At the time of testing the vehicle was fully charged to nearly 53v the charging of battery was done using the DC charger connected to 220v power source. The drop in battery voltage with the distance travel by vehicle increases shown in **Fig 4.8**.

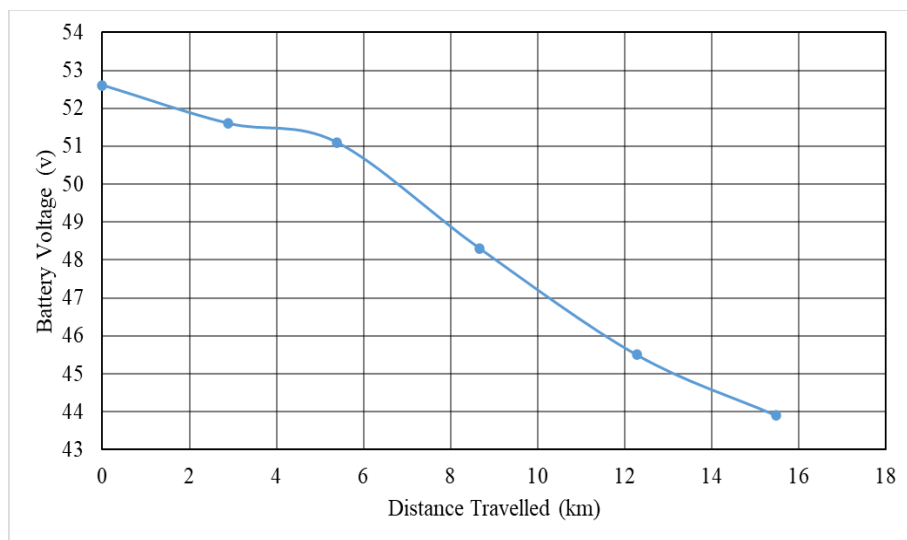

Fig 4.8 Characteristics for drain in battery voltage vs distance travelled by vehicle

The drain characters of battery shows the range of vehicle was about 16km by testing the vehicle at highest and lowest speed with incline and decline roads.

After testing the vehicle till the battery last which was nearly 43v which was controlled by the controller considering the depth of discharge for battery below this voltage it takes a high power charger to charge the battery. So, the battery is charged once again to understand the charging characteristics, require time to charge the battery as shown in **Fig 4.9**.

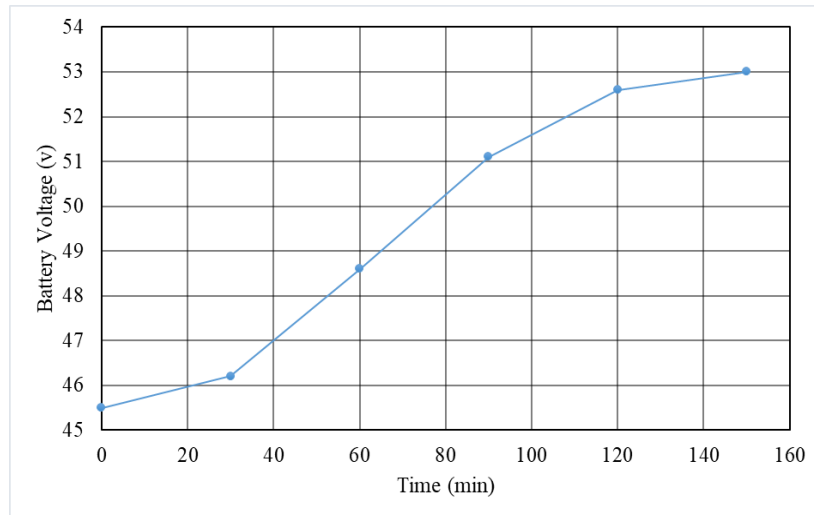

Fig 4.9 Increase in Battery Voltage w.r.t. charging time

The time required to charge the battery from 43v to 53v was about 150 min using 220v charger.

To identify the increase in temperature of battery during charging the testing was done by measuring the temperature of battery at the time of charging after every 30 minutes using temperature gun, the temperature variation during charging is shown in **Fig 4.10**.

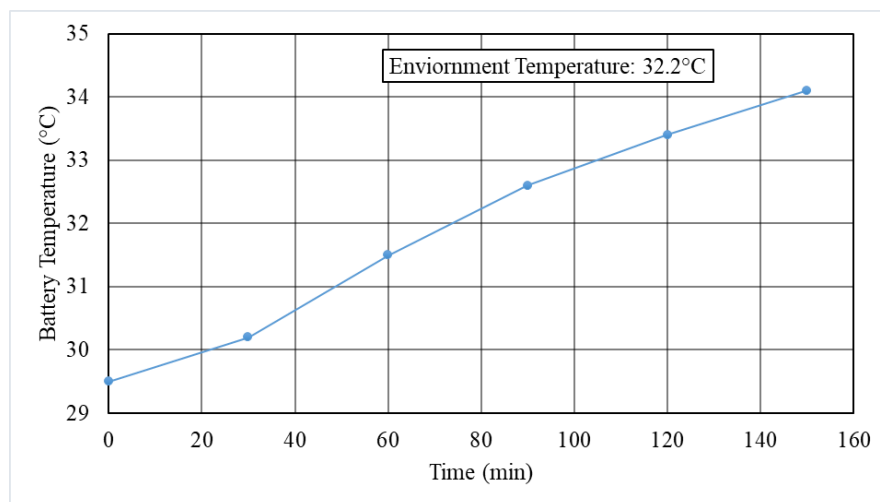

Fig 4.10 Temperature Variation of Battery w.r.t. time during charging

The test results show the temperature of battery increases with increase in voltage and charging time, as the temperature of battery rises from 29.5°C to 34.2°C with the increase in voltage from 43 to 53 V in 150 min.

4.7 Battery heat generation

The numerical calculation was performed to calculate the Joule heating, the major factor considered are power, current and C_{rate} of battery as previously discussed in chapter III in section 3.9. As the heat generation in battery is a major element in finding out the highest temperature in battery. The calculation results was carried out to find the value of heat generated on the battery pack with change in current drawn from battery **Fig 4.11**.

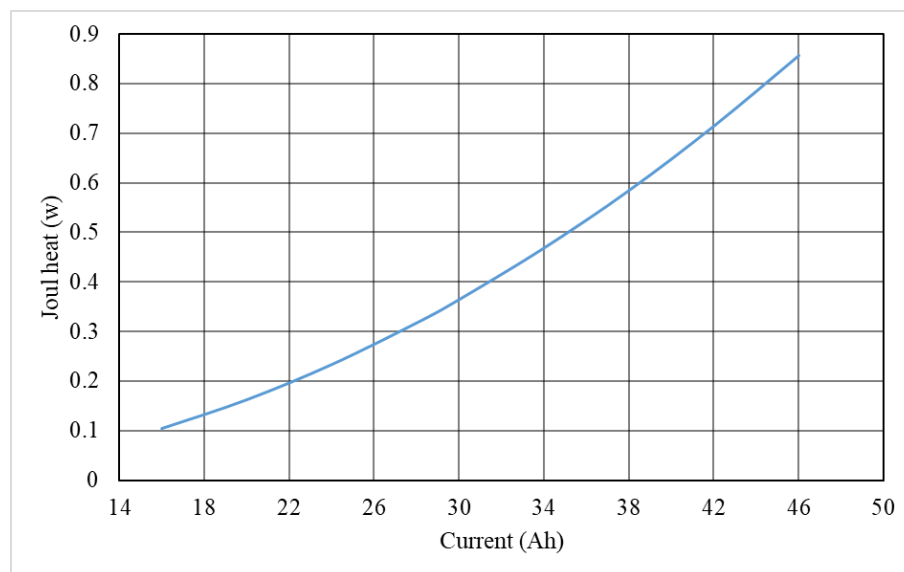

Fig 4.11 Heat generation in battery w.r.t. current drawn from battery by motor

The calculated results shows when the current of motor 16Ah drawn from battery the resistance in battery causes heat generation which is 0.1W at initial stage which increases to 0.85W when the current drawn from motor is at its peak.

4.8 Convection heat transfer

The convection heat transfer equation was used to calculate the maximum temperature on cell surface, the results carried out considering the joule heating value as heat flow, material properties, and environment temperature. Considering all the

factors a graph was plotted between temperature and Joule heat W using convection heat transfer equation as shown in **Fig 4.12**.

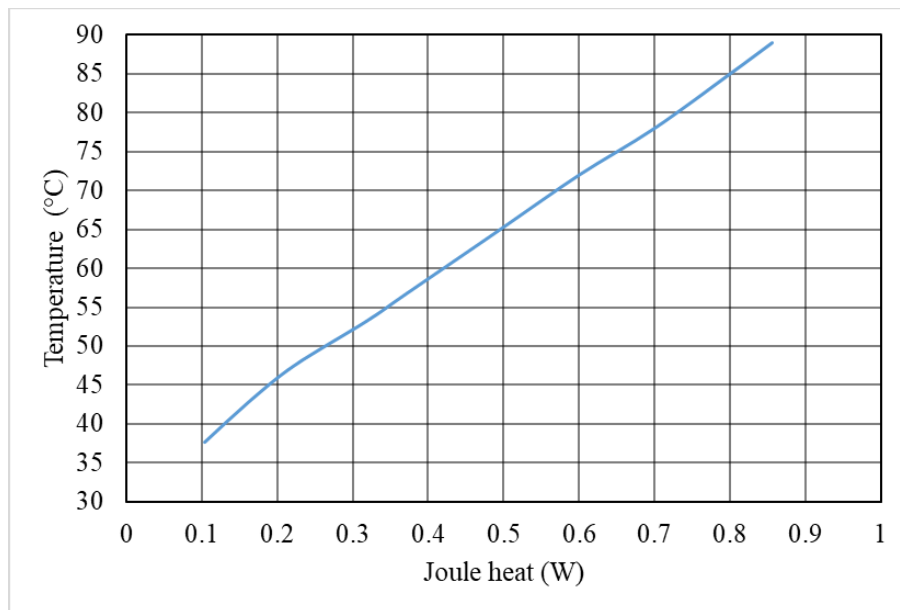

Fig 4.12 Increase in temperature in battery w.r.t. Joule heat

To simplify the understanding of increase in temperature the graph is plotted between temperature and speed of vehicle as shown in **Fig 4.13** the speed of vehicle is verified by the current drawn by motor under section 4.7.

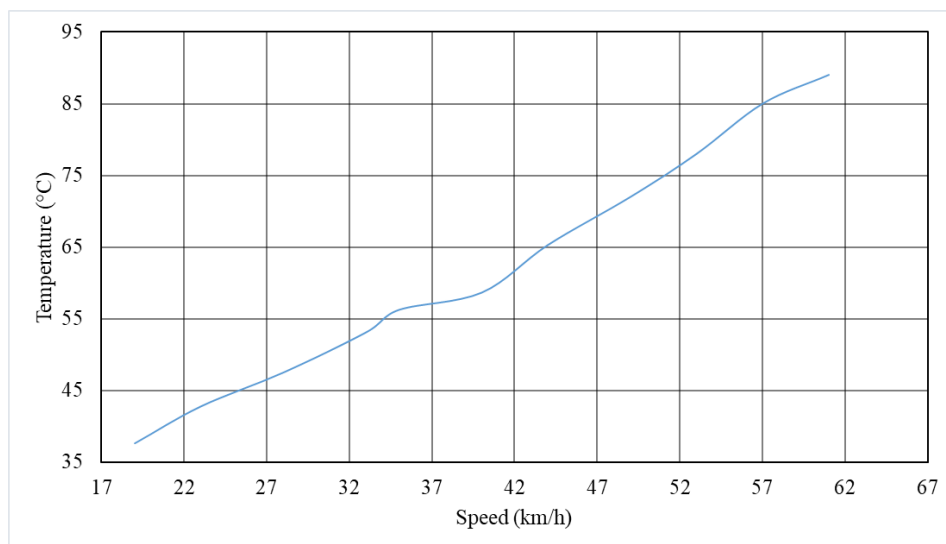

Fig 4.13 Increase in temperature in battery w.r.t. speed of vehicle

The results obtained shows the increase in temperature in battery due to increasing the speed of scooter, running the scooter at 55km/h generated the temperature of 80°C which exceeds the critical temperature limit i.e., 80°C of battery before thermal

runaway occurs as said by Tete et al. (2021), this shows the worst effect of high temperature in battery or even at low temperature the efficiency of battery is affected.

4.9 CFD simulation

The CFD simulations were performed to find out the optimum air flow rate to understand the heat distribution pattern in battery cell. To know the temperature distribution on cell surface steady state thermal analysis was done and the temperature distribution on surface is shown in **Fig 4.14** Which indicates the heat generated inside the cell was transferred to the cell surface which confirm that cooling the cell surface directly cools the cell from inside.

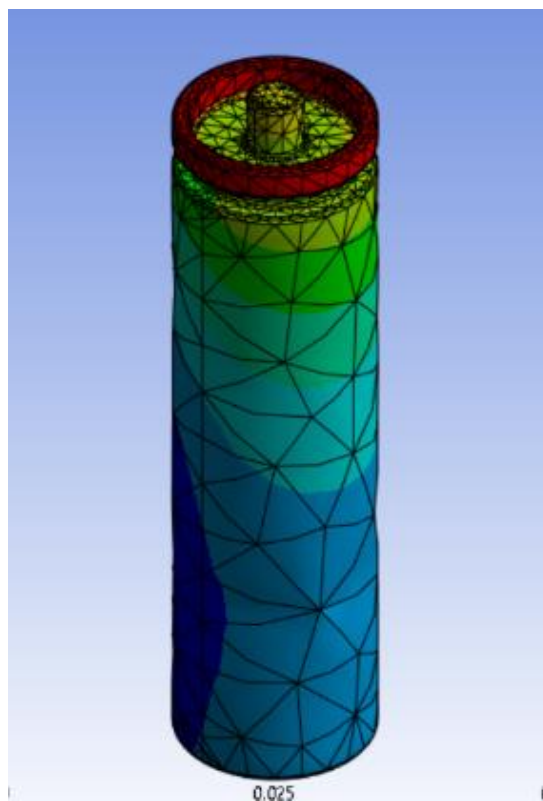

Fig 4.14 The heat distribution on cell surface

Once again, the Hybrid Electric Scooter was tested at high speed on the next day 18th September 2022 where the environmental temperature was same 32.2°C, the test characteristics are shown in **Table 4.4**.

Table 4.4 Test characteristics for battery temperature

| S. No. | Time interval (min) | Battery Temperature(°C) | Average Speed (km/hr) | Distance Travelled (km) |
|---------------|----------------------------|--------------------------------|------------------------------|--------------------------------|
| 1 | 0 | 29.5 | - | 0 |
| 2 | 10:03 | 30.6 | 23.5 | 3.94 |
| 3 | 10:08 | 32.6 | 24.9 | 8.15 |
| 4 | 10:27 | 33.7 | 24.4 | 12.42 |

The CFD simulation was performed to carry out the results of air cooling on battery with a certain temperatures and air velocity with the boundary condition shown in **Table 4.5**.

Table 4.5 Boundary conditions

| No. of cases | 1 | 2 | 3 |
|------------------------------|----------|----------|----------|
| Speed of vehicle (km/h) | 0 | 15 | 25 |
| Air speed (m/s) | 0 | 4.16 | 6.94 |
| Joule heating(w) | 0 | 0.08 | 0.19 |
| Experimental temperature(°C) | 29.5 | 32.6 | 33.7 |
| Numerical temperature(°C) | 29.5 | 35 | 45 |

ANSYS fluent solution was used to simulate solutions for all the boundary conditions. In the present work the solution method was kept simple. Hybrid initialization and calculations were done for 50 iterations, where solution was conversed. The results were processed and observed by using the post processor in FLUENT where the results simulated were computed, i.e. temperature volume rendering, velocity streamline and contours.

The volume rendering of temperature along the cells and the battery pack, in both enclosure is shown in **Fig 4.15**. The velocity distribution of steamlines for air flow distribution for both cells and battery pack enclosures is shown below in the **Fig 4.16**.

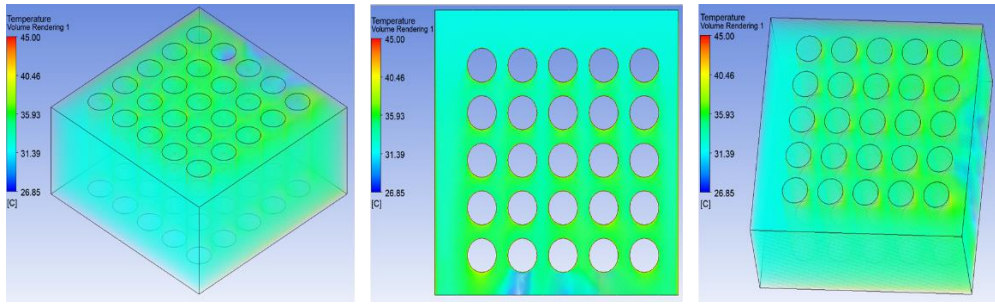

(a) Temperature volume rendering inside cells enclosure

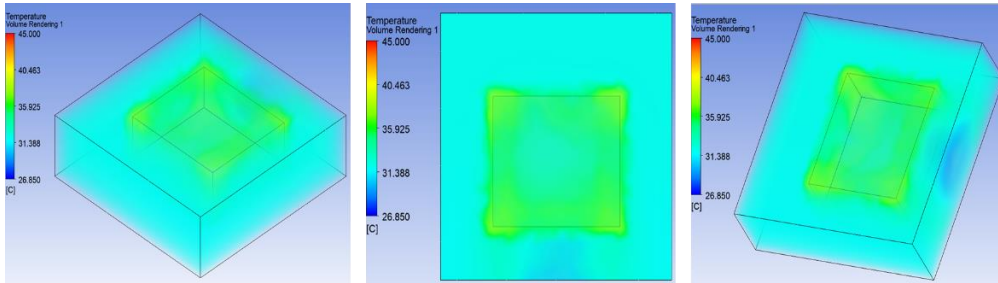

(b) Temperature volume rendering inside battery pack enclosure

Fig 4.15 The temperature volume rendering of air flow inside enclosure

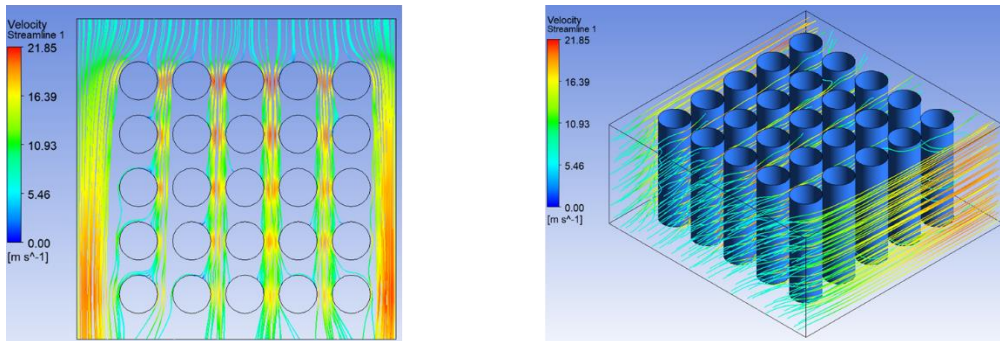

(a) The velocity streamlines distribution inside cells enclosure

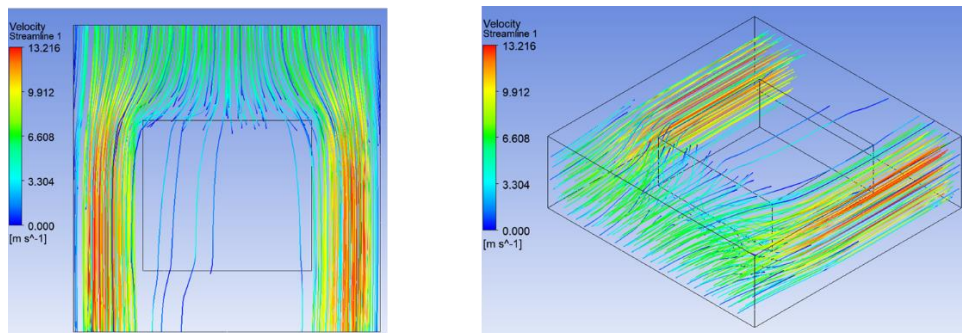

(b) The velocity streamlines distribution inside battery pack enclosure

Fig 4.16 The Velocity streamlines distribution of airflow inside enclosure

The comparison of inlet air flow effect for 4.16 m/s and 6.94 m/s air speed is shown in **Fig 4.17 & Fig 4.18**, which shows the distribution of air inside the enclosures.

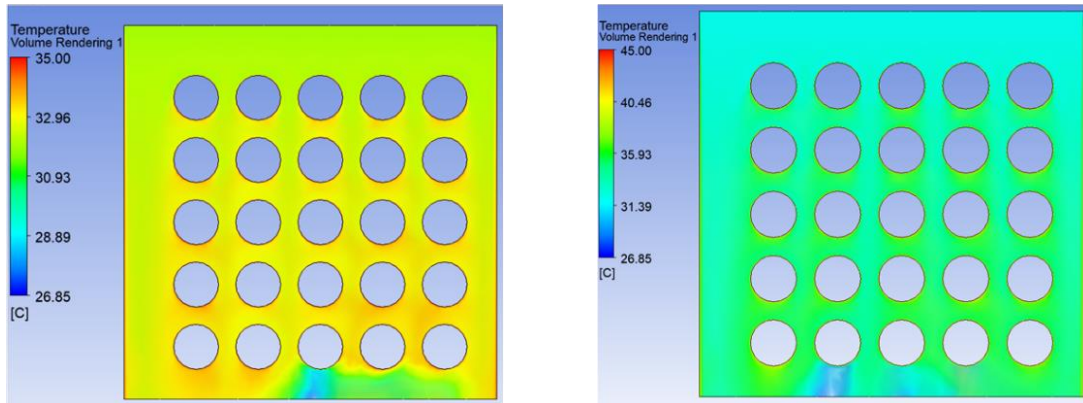

(i) Air inlet at 4.16 m/s

(ii) Air inlet at 6.94 m/s

(a) Temperature volume rendering comparison inside cell enclosure

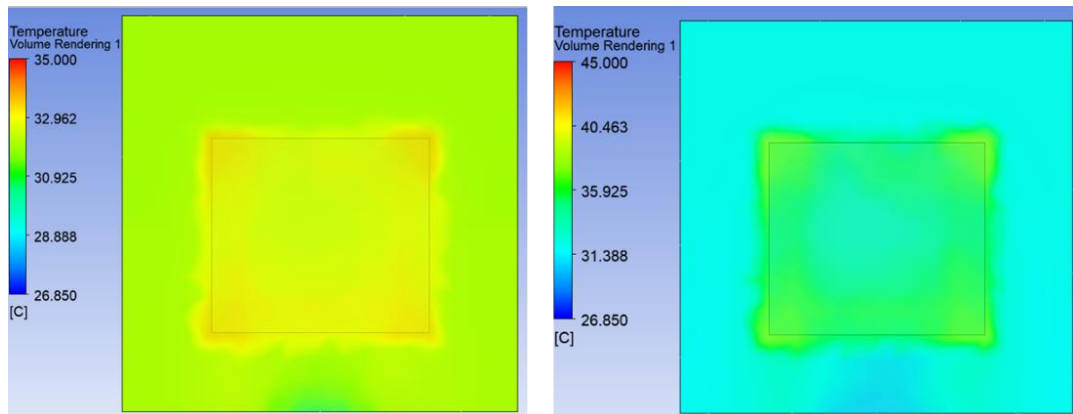

(i) Air inlet at 4.16 m/s

(ii) Air inlet at 6.94 m/s

(b) Temperature volume rendering comparison inside battery pack enclosure

Fig 4.17 Temperature volume rendering comparison for battery cooling at different inlet air speed

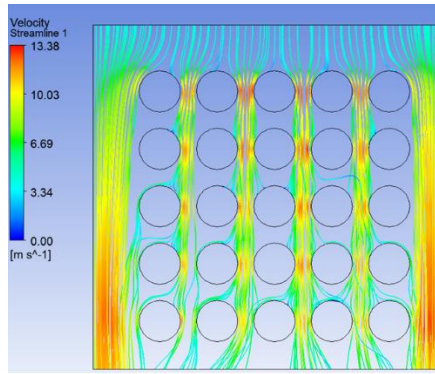

(i) Air inlet at 6.94 m/s

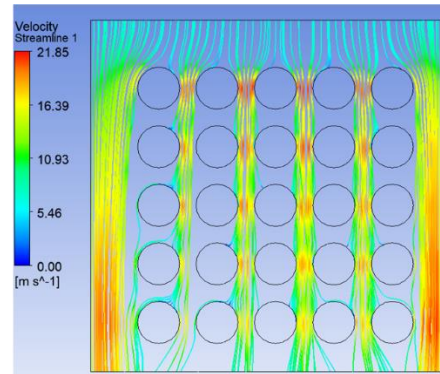

(ii) Air inlet at 6.94 m/s

(a) Velocity streamline comparison inside cell enclosure

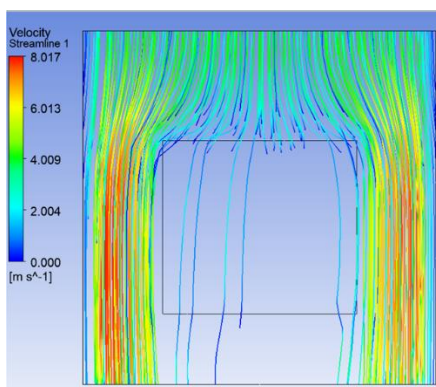

(i) Air inlet at 6.94 m/s

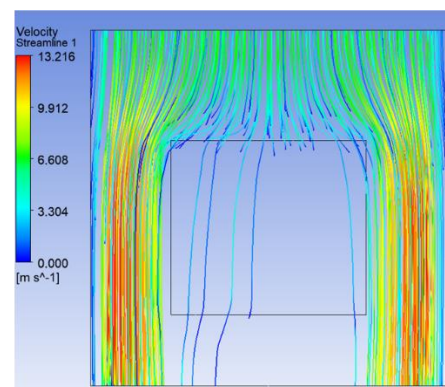

(ii) Air inlet at 6.94 m/s

(b) Velocity streamline comparison inside cell enclosure

Fig 4.18 Velocity streamlines comparison for battery cooling at different inlet air speed

From the simulation performed by comparing the temperature volume rendering and velocity streamlines at different inlet air speed as of the vehicle speed. The results show decrease in temperature of battery, increases in heat transfer, and better distribution of air as the speed of vehicle increases. These results validate the cooling system made will decrease the temperature of battery as the vehicle speed increases.

Various inlet airflow speeds are considered, which were taken from the testing data. The temperature was assigned with the inlet of air on cells and battery surface inside enclosure to show the temperature distribution temperature contours were made the results are shown in **Fig 4.19** and **Fig 4.20**.

(a) Vehicle is stationary 0 kmph

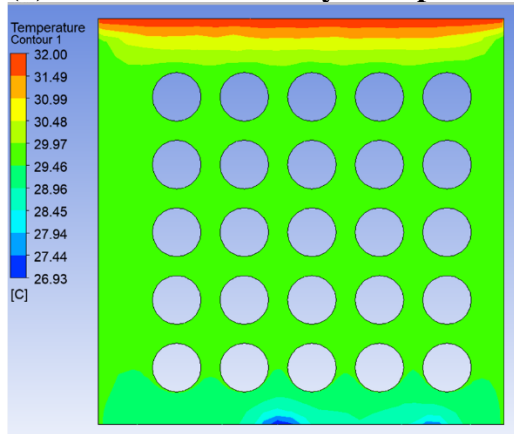

(b) Vehicle running at 15kmph

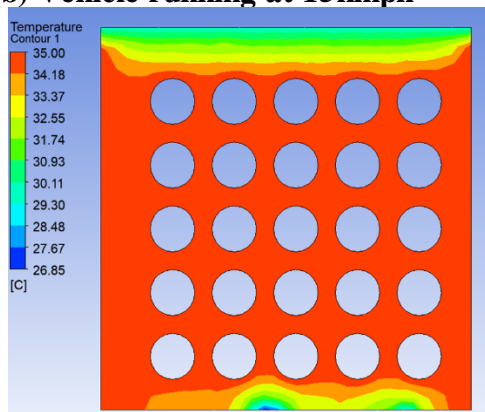

(i) Cells isolated

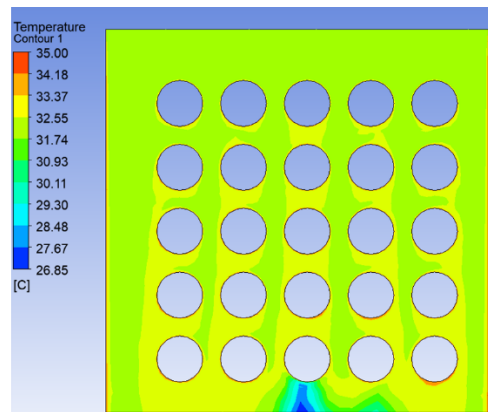

(ii) Cells exposed to forced air (4.16 m/s)

(c) Vehicle running at 25kmph

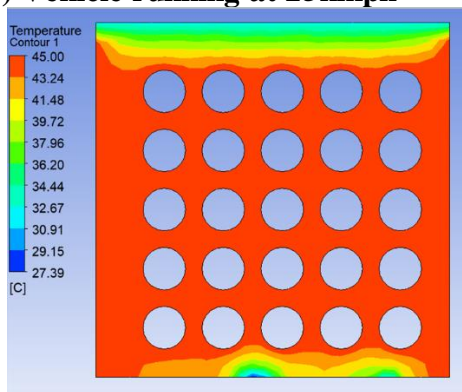

(i) Cells isolated

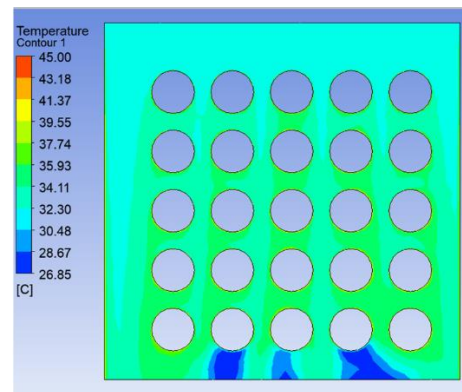

(ii) Cells exposed to forced air (6.94 m/s)

Fig 4.19 Effects of cooling on cells surface with inlet air flow at different speed of vehicle

(a) Vehicle is stationary 0 kmph

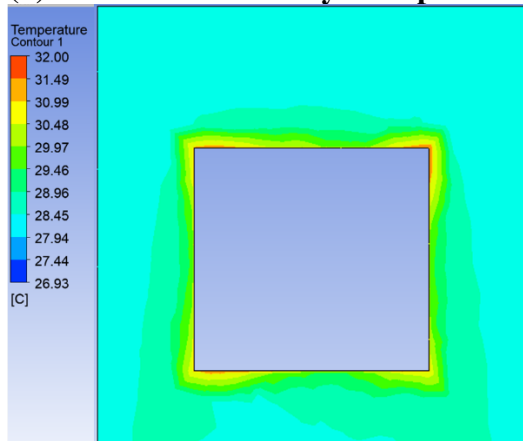

(b) Vehicle running at 15 kmph

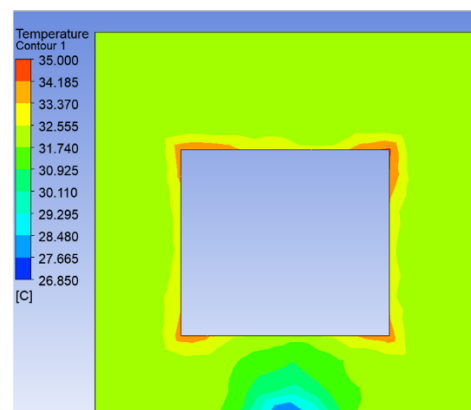
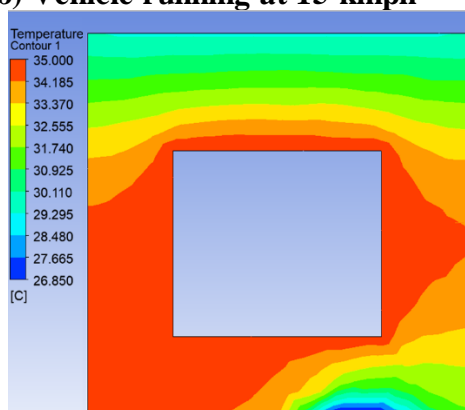

(i) Battery pack isolated

(ii) Battery pack exposed to forced air (4.16 m/s)

(c) Vehicle running at 25 kmph

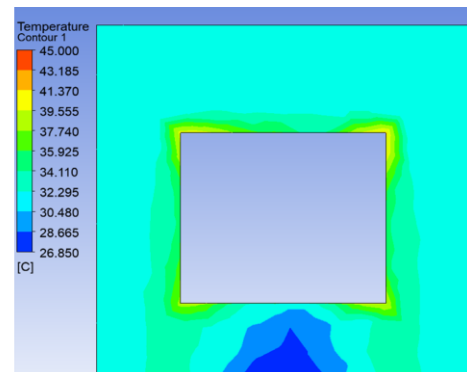
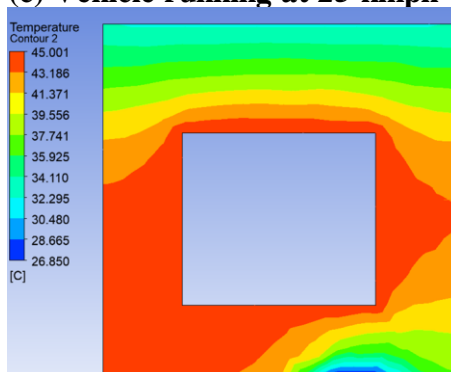

(i) Battery pack isolated

(ii) Battery pack exposed to forced air (6.94 m/s)

Fig 4.20 Effect of cooling on battery pack surface with inlet air flow at different speed of vehicle

The comparisons results shown the decrease in temperature as the air inlet velocity increases. This result helps to compare the case of cooling when the battery cells

enclosures were isolated and when they were open for air flow, the decrease in temperature lower the chances of thermal runaway and fire in battery. It can be seen that the decrease in temperatures of the battery cells and battery pack surface is directly dependent on the inlet air flow velocity. These results will also help in increasing the efficiency and life of battery which is affected by temperature.

CONCLUSIONS AND FUTURE SCOPE

5.1 CONCLUSIONS

The conventional scooter with a two-stroke engine was successfully converted into the Hybrid Electric Scooter (HES). This scooter can be charged in Plug-in mode with a very convenient 48 V DC adaptor, which consumes just 5 A of electric current. When the scooter was being used on the internal combustion engine mode, it charges the battery through power regeneration in the front wheel.

In this thesis, the development of HES, testing of converted HES, CAD model of battery cooling method was shown.

The key findings and results are:-

- The calculation for selecting motor and battery for scooter was done and the numerical results shown the increase in power and battery capacity requirement as the weight, range and top speed increases.
- The developed HES possesses the ability to operate in three operating modes i.e., a hybrid mode, fully electric mode and internal combustion engine mode.
- The test results show promising range of 20-25 km in a single charge with rider weight of 75 kg which makes it sufficient for rural and city driving.
- The increase in battery temperature due to increase in speed and time of travelling, was calculated on the cell surface using joule heating and convection heat transfer equations but increase in temperature beyond 80°C causes thermal runaway which may cause fire in battery.
- To save the battery of scooter from thermal runaway caused due to increase in temperature of battery, the CFD simulation was carried out for understanding the internal cooling pattern of battery by using Ansys 2021 R1.
- The CFD analysis was carried out for both battery pack walls and cells wall inside battery pack. The different air velocity of 15km/h & 25km/h was considered for air inlet, the results temperature was assigned to the cells and battery pack surface and was verified by testing results. The results obtain shows promising results of

reducing temperature of cells and pack about 3-4°C, with the more increase in flow of air the more decrease in temperature.

- The battery packing is required for cells but the proper cooling of them is also necessary to make them more efficient and increase their life.
- This scooter fairly reduces the dependence on the fossil fuels while overcoming the problems of EV charging infrastructure, which is absent in rural India.

5.2 Future scope

In consideration with the literature reviewed and present scope of thesis, following areas can be worked and applied to the existing model :

- In the current scope the Hybrid Electric Scooter (HES) was charged through three mediums. In the future, it can further expand to renewable energy sources i.e., charging through solar panels.
- To improve the user experience of HES more research can be done on the battery structure to improve its capacity.
- To improve the battery cooling the placement of battery can be varied to the most airy location.

REFERENCES

- Ali, M. U., Zafar, A., Nengroo, S. H., Hussain, S., Alvi, M. J., & Kim, H. J. 2019. A smarter battery management system for electric vehicle applications: A critical review of lithium-ion battery state of charge estimation. *Energies* **12** : 446-479.
- Chakraborty, R., & Chakravarty, S. 2023. Factors affecting acceptance of electric two-wheelers in India: A discrete choice survey. *Transport Policy* **132** : 27–41.
- Chen, R., Liu, X., Miao, L., and Yang, P. 2020. Electric vehicle tour planning considering range anxiety. *Sustainability* **12** : 3685-3702.
- Chen, W., Liang, J., Yang, Z., and Li, G. 2019. A review of lithium-ion battery for electric vehicle applications and beyond. In *Energy Procedia* **158** : 4363–4368.
- Cicconi, P., Germani, M., and Landi, D. 2013. Modeling and thermal simulation of a PHEV battery module with cylindrical LFP cells. *World Electric Vehicle Journal* **6** : 175–185.
- Dhinakaran, V., Surendran, R., Varsha Shree, M., and Gupta, P. 2021. Study on Electric Vehicle (EV) and Its Developments Based on Batteries, Drive System and Charging Methodologies in Modern World. *Green Energy and Technology*, pp. 103–118.
- Enos, G., David G. 2014. Understanding the Function and Performance of Carbon-enhanced Lead-acid Batteries. A report submitted to Sandia National Laboratories, United States.
- Glenn, J., Bluth, M., Christianson, M., Pressley, J., Taylor, A., Macfarlane, G. S., and Chaney, R. A. 2020. Considering the potential health impacts of electric scooters: An analysis of user reported behaviors in provo, Utah. *International Journal of Environmental Research and Public Health* **17** : 1–15.
- Goel, S., Sharma, R., and Rathore, A. K. 2021. A review on barrier and challenges of electric vehicle in India and vehicle to grid optimisation. *Transportation Engineering* **4** : 100057-100071.
- Hardt, C., & Bogenberger, K. 2019. Usage of e-Scooters in Urban Environments. In *Transportation Research Procedia* **37** : 155–162.
- Jilte, R. D., & Kumar, R. 2018. Numerical investigation on cooling performance of Li-ion battery thermal management system at high galvanostatic discharge. *Engineering Science and Technology, an International Journal* **21** : 957–969.

- John Jiby, B., and Shirase, R. 2019. Present and Future Trends for Electric Vehicles in India Present and Future Trends for Electric Vehicles in India INTRODUCTION. *Journal-CASS Studies* **3** : 264–279.
- Khandar, C., and S. Kosankar. A Review of Vehicular Pollution in Urban India and Its Effects on Human Health. 2014. *Journal of Advanced Laboratory Research in Biology* **5** : 54-61.
- Khande, M. S., Patil, A. S., Andhale, G. C., & Shirsat, R. S. (2020). IRJET-Design and Development of Electric scooter Cite this paper Design and Development of Electric scooter. *International Research Journal of Engineering and Technology* **7** : 359-364.
- Khurana, A., Kumar, V. V. R., and Sidhuria, M. 2020. A Study on the Adoption of Electric Vehicles in India: The Mediating Role of Attitude. *Vision* **24** : 23–34.
- Lee, J. Y., Woo, B. C., Kim, J. M., and Oh, H. S. 2017. In-wheel motor design for an electric scooter. *Journal of Electrical Engineering and Technology* **12** : 2307–2316.
- Li, X., Tan, Y., Liu, X., Liao, Q., Sun, B., Cao, G., Li, C., Yang, X., & Wang, Z. 2020. A cost-benefit analysis of V2G electric vehicles supporting peak shaving in Shanghai. *Electric Power Systems Research* **179** : 106058-106067.
- Lu, M., Zhang, X., Ji, J., Xu, X., and Zhang, Y. 2020. Research progress on power battery cooling technology for electric vehicles. *Journal of Energy Storage* **27** : 101155-101171.
- Lu, Z., Meng, X. Z., Wei, L. C., Hu, W. Y., Zhang, L. Y., & Jin, L. W. 2016. Thermal management of densely-packed EV battery with forced air cooling strategies. In *Energy Procedia* **88** : 682–688.
- Malik, M., Dincer, I., & Rosen, M. A. 2016. Review on use of phase change materials in battery thermal management for electric and hybrid electric vehicles. *International Journal of Energy Research* **40** : 1011-1031
- Miao, Y., Hynan, P., Von Jouanne, A., and Yokochi, A. 2019. Current li-ion battery technologies in electric vehicles and opportunities for advancements. *Energies. MDPI AG* **12** : 1074-1094.

- Noel, L., Zarazua de Rubens, G., Sovacool, B. K., & Kester, J. 2019. Fear and loathing of electric vehicles: The reactionary rhetoric of range anxiety. *Energy Research and Social Science* **48** : 96–107.
- Pevec, D., Babic, J., Carvalho, A., Ghiassi-Farrokhfal, Y., Ketter, W., and Podobnik, V. 2020. A survey-based assessment of how existing and potential electric vehicle owners perceive range anxiety. *Journal of Cleaner Production* **276** : 122779-12306.
- Racewicz, S., Kazimierczuk, P., Kolator, B., & Olszewski, A. 2018. Use of 3 kW BLDC motor for light two-wheeled electric vehicle construction. In IOP Conference Series: *Materials Science and Engineering* **421** : 04067-04078 .
- Saju, C., Angel Michael, P., & Jarin, T. 2022. Hybrid electric car comparison to increase the reliability for fuel efficiency. *Renewable Energy Focus* **43** : 309–316.
- Sheu, K. B. 2008. Simulation for the analysis of a hybrid electric scooter powertrain. *Applied Energy* **85** : 589–606.
- Shimamura, O., Abe, T., Watanabe, K., Ohsawa, Y., & Horie, H. 2007. Research and development work on lithium-ion batteries for environmental vehicles. *World Electric Vehicle Journal* **1** : 251–257.
- Tarabay, J., & Karami, N. 2015. Nickel Metal Hydride battery: Structure, chemical reaction, and circuit model. In *Third International Conference on Technological Advances in Electrical, Electronics and Computer Engineering*, pp. 22–26.
- Tete, P. R., Gupta, M. M., & Joshi, S. S. 2021. Developments in battery thermal management systems for electric vehicles: A technical review. *Journal of Energy Storage* **35** : 102255-102318.
- Tseng, C.Y., Yu, C.H. & Lin, Y.T. Development of an auxiliary mode powertrain for hybrid electric scooter. 2014. *International Journal of Automotive Technology* **15** : 805–814.
- Un-Noor, F., Padmanaban, S., Mihet-Popa, L., Mollah, M. N., & Hossain, E. 2017. A comprehensive study of key electric vehicle (EV) components, technologies, challenges, impacts, and future direction of development. *Energies* **10** : 1217-1301.

- Vo-Duy, T., Nguyen, B. H., Ta, M. C., Trovao, J. P., & Nguyen, N. H. P. 2020. Different voltage and current control schemes for multi-pack battery of electric scooters. In *IEEE Vehicle Power and Propulsion Conference* **14** : 3373-3396.
- Xu, Y., Wang, Z., Li, Y., & Xin, A. 2012. Research on the model of EV battery and charger. *Proceedings - Power Engineering and Automation Conference*, pp. 1-4.
- Yaohua, L., Ying, W., & Xuan, Z. 2015. Modelling and simulation study on a series-parallel hybrid electric vehicle. *World Electric Vehicle Journal* **7** : 133–141.
- Zhang, R., Xia, B., Li, B., Cao, L., Lai, Y., Zheng, W., Wang, W. 2018. State of the art of lithium-ion battery SOC estimation for electrical vehicles. *Energies* **11** : 1820-1856.
- Zhang, B., Niu, N., Li, H., Wang, Z., & He, W. 2021. Could fast battery charging effectively mitigate range anxiety in electric vehicle usage? Evidence from large-scale data on travel and charging in Beijing. *Transportation Research Part D: Transport and Environment* **95** :102840-102853.
- https://www.mycarhelpline.com/index.php?option=com_easyblog&view=entry&id=808&Itemid=91. (Accessed on 19th November 2022).
- <https://www.news18.com/news/auto/watch-electric-scooter-on-fire-after-battery-explosion-raises-doubts-on-safety-of-ev-4266893.html>. (Accessed on 29th November 2022).
- <https://www.researchnester.com/reports/forklift-battery-market/2749>. (Accessed on 7th December 2022).
- <https://www.team-bhp.com/forum/motorbikes/53094-project-hybrid-add-kit-scooter.html>. (Accessed on 10th December 2022).
- <https://www.etrnio.in/blog/history-of-electric-vehicles.html>. (Accessed on 27th December 2022).
- <https://www.energy.gov/articles/history-electric-car>. (Accessed on 27th December 2022).
- <https://council.science/current/blog/climate-explained-why-is-the-arctic-warming-faster-than-other-parts-of-the-world/>. (Accessed on 5th November 2022).

<https://economictimes.indiatimes.com/electric-vehicles-to-save-60-billion-in-fuel-costs-by-2030-niti-aayog/articleshow/58642799.cms?from=mdr>. (Accessed on 1st November 2022).

<https://timesofindia.indiatimes.com/auto/policy-and-industry/ev-fires-morth-govt-pushes-new-ev-battery-safety-norms-deadline-to-1-december-2022/articleshow/94483436.cms>. (Accessed on 1st November 2022).

ABSTRACT

As the number of vehicles on the road rises, so too does the problem of emissions generated by vehicles tailpipes. These vehicles are primarily powered by internal combustion engines (ICEs), which burn fossil fuels for power, releasing harmful gases that affect both environment and humankind. For the sake of our environment, now is the moment to transit from conventional vehicle to an electric vehicle that emits no exhaust emissions. Since scooters make up a large fraction of the vehicles on the road, changing them to electric scooter will contribute to the reduction of toxic gases released into the atmosphere. Electric scooters come in three varieties: electric scooter, hybrid electric scooter, and plug-in hybrid electric scooter. The hybrid electric scooter (HES) is the most promising among these varieties since the hybrid system can be installed on existing scooters, resulting in a low-cost conversion to an electric scooter, no waste, a longer range, and reduced emissions.

The presented model in this thesis has been converted into hybrid electric scooter from conventional scooter. The converted hybrid electric scooter will be powered by a BLDC motor which drive the front wheel of the scooter, connecting with a battery placed at the boot of scooter.

When electric scooter is driven for a long distance, its battery heats up and there is a risk of fire, so in this thesis a CAD model of battery cooling has been developed and its cooling has been numerically studied. The CAD model analysis results were validated with the testing results of HES and numerical calculation results were used as it shows the results inside the battery cell, using ANSYS Fluent simulation cells and battery pack surface was provide with air flow and cooling pattern observed. It was found that proper internal cooling of battery could reduce the overall battery temperature, which could reduce the chances of Electric Scooter catching fire.

सारांश

जैसे-जैसे सड़क पर वाहनों की संख्या बढ़ती जा रही है, वैसे-वैसे वाहनों के टेलपाइप से उत्पन्न उत्सर्जन की समस्या भी बढ़ रही है। ये वाहन मुख्य रूप से आंतरिक दहन इंजन (Internal Combustion Engine) द्वारा संचालित होते हैं, जो उर्जा के लिए जीवाश्म ईंधन जलाते हैं, हानिकारक गैसों को छोड़ते हैं जो पर्यावरण और मानव जाति दोनों को प्रभावित करते हैं। हमारे पर्यावरण के लिए, अब एक ऐसे इलेक्ट्रिक वाहन को अपनाने का समय है जो कोई निकास उत्सर्जन नहीं करता हो। चूंकि स्कूटर सड़क पर वाहनों का एक बड़ा हिस्सा बनाते हैं, इसलिए उन्हें इलेक्ट्रिक स्कूटर में बदलने से वातावरण में जहरीली गैसों को कम करने में मदद मिलेगी। इलेक्ट्रिक स्कूटर तीन किस्मों में आते हैं: इलेक्ट्रिक स्कूटर, हाइब्रिड इलेक्ट्रिक स्कूटर और प्लग-इन हाइब्रिड इलेक्ट्रिक स्कूटर। हाइब्रिड इलेक्ट्रिक स्कूटर (HES) इन किस्मों में सबसे अधिक आशाजनक है क्योंकि मौजूदा स्कूटरों पर हाइब्रिड सिस्टम स्थापित किया जा सकता है, जिसके परिणामस्वरूप इलेक्ट्रिक स्कूटर में कम लागत का रूपांतरण होता है, कोई अपशिष्ट नहीं होता है, एक लंबी रेंज और कम उत्सर्जन होता है।

इस थीसिस में प्रस्तुत मॉडल को पारंपरिक स्कूटर से हाइब्रिड इलेक्ट्रिक स्कूटर में बदला गया है। परिवर्तित हाइब्रिड इलेक्ट्रिक स्कूटर एक BLDC मोटर द्वारा संचालित होगा जो स्कूटर के बूट पर रखी बैटरी से जुड़कर स्कूटर के अगले पहिये को चलाता है।

इलेक्ट्रिक स्कूटर को ज्यादा दूरी पर चलने पर उसकी बैटरी गर्म होजाती है ओर उसमे आग लगने का खतरा बन जाता है, इसलिए इस थीसिस में बैटरी कूलिंग का एक CAD मॉडल विकसित किया है ओर उसके ठन्डे होने का संख्यात्मक अध्यन किया गया है। प्रणाली, चयनित मापदंडों को एचईएस के परीक्षण परिणामों के साथ मान्य किया गया था और संख्यात्मक गणना परिणामों का उपयोग किया गया था क्योंकि यह बैटरी सेल के अंदर परिणाम दिखाता है, ANSYS फ्लुएंट सिमुलेशन कोशिकाओं का उपयोग करके और बैटरी पैक सतह को वायु प्रवाह प्रदान किया गया था और शीतलन पैटर्न देखा गया था जो कम दिखाता है तापमान में जो इलेक्ट्रिक स्कूटर के आग पकड़ने की संभावना को कम करने में मदद करेगा।

LIST OF PUBLICATION

Upadhyay, J., Salvi, B.L., Khidiya, M.S., Agarwal, C (2023). State-of-the-art in Hybrid Electric Scooter: Scopes and challenges ahead in Indian scenario, is accepted for presentation in an International Conference on ‘Advances in Power Generation, Renewable Energy and Sustainable Development – 2023’, to be held during Feb 3-4, 2023, organized by Rajasthan Technical University, Kota.