

**Investigating Confederated Three-Phase Solar Photovoltaic
and Unified Power Quality Conditioner Configuration**

**तीन चरण सौर फोटो वोल्टिक और संयुक्त विद्युत गुणवत्ता
कंडीशनर कॉन्फ़िगरेशन की एकीकृत जांच**

Yashvi Mudgal

Thesis

**Master of Technology in Electrical Engineering
(With Specialization in Power Electronics)**



2019

**Department of Electrical Engineering
College of Technology and Engineering
Maharana Pratap University of Agriculture & Technology, Udaipur**

**Investigating Confederated Three-Phase Solar Photovoltaic
and Unified Power Quality Conditioner Configuration**

**तीन-चरण सौर फोटोवोल्टिक और एकीकृत संयुक्त विद्युत
गुणवत्ता कंडीशनर कॉन्फिगरेशन की जांच**

Thesis

Submitted to the

Maharana Pratap University of Agriculture & Technology, Udaipur

**In Partial Fulfillment of the Requirement for
the Degree of**

**Master of Technology in Electrical Engineering
(With Specialization in Power Electronics)**



By

Yashvi Mudgal

2019

COLLEGE OF TECHNOLOGY AND ENGINEERING
MAHARANA PRATAP UNIVERSITY OF AGRICULTURE & TECHNOLOGY, UDAIPUR

CERTIFICATE – I

Date: 16-08-2019

This is to certify that **Miss Yashvi Mudgal** student of **Electrical Engineering** has successfully completed the comprehensive examination held on 20-01-2019 as required under the regulations for Post-Graduate Studies.

Dr. R.R. Joshi

Head

Department of Electrical Engineering
College of Technology and Engineering
Udaipur

CERTIFICATE – II

Date: 16-08-2019

This is to certify that this thesis entitled “**Investigating Confederated Three-Phase Solar Photovoltaic and Unified Power Quality Conditioner Configuration**” submitted for the degree of **Master of Technology** in the subject of **Electrical Engineering (Power Electronics)** embodies bonafide research work carried out by **Miss Yashvi Mudgal** under my guidance and supervision and that no part of this thesis has been submitted for any other degree. The assistance and help received during the course of investigation have been fully acknowledged.

The draft of the thesis was also approved by the advisory committee on 09-07-2019.

(Dr. Vinod Kumar Yadav)

Major Advisor

Department of Electrical Engineering
College of Technology and Engineering
Udaipur

(Dr. R.R. Joshi)

Head

Department of Electrical Engineering
College of Technology and Engineering,
Udaipur

(Dr. Ajay Kumar Sharma)

DEAN

College of Technology and Engineering, Udaipur

Date: 16-08-2019

CERTIFICATE – III

This is to certify that this thesis entitled “**Investigating Confederated Three-Phase Solar Photovoltaic and Unified Power Quality Conditioner**” submitted by Miss **Yashvi Mudgal** to Maharana Pratap University of Agriculture and Technology, Udaipur, in partial fulfilment of the requirements for the degree of **Master of Technology in Electrical Engineering** in the subject of **Power Electronics** after recommendation by the external examiner was defended by the candidate before the following members of the examination committee. The performance of the candidate in the oral examination held on 13-08-2019 has been found satisfactory; we therefore, recommend that the thesis be approved.

Dr. Vinod Kumar Yadav
Major Advisor

Dr. R.R. Joshi
Advisor

Miss Kalpana Jain
Advisor

Dr. M.S. Khidiya
DRI Nominee

Dr. R.R. Joshi
HEAD, Electrical

Dr. Ajay Kumar Sharma
DEAN, CTAE

Approved

DIRECTOR RESIDENT INSTRUCTION
MPUAT, Udaipur

Date: 16-08-2019

CERTIFICATE – IV

This is to certify that **Miss Yashvi Mudgal** student of **Master of Technology, Electrical Engineering** has made all corrections/modifications in the thesis entitled **“Investigating Confederated Three-Phase Solar Photovoltaic and Unified Power Quality Conditioner”** which were suggested by the external examiner and the advisory committee in the oral examination held on 13-08-2019. The final copies of the thesis duly bound and corrected were submitted on 16-08-2019.

Dr. R.R. Joshi
Head

Dr. Vinod Kumar Yadav
Major Advisor

ACKNOWLEDGEMENT

I take it to be my proud privilege to avail this opportunity to express my sincere and deep sense of gratitude to my learned advisor **Dr. Vinod Kumar** for his guidance, constructive suggestions, keen and sustained interest and incessant encouragement bestowed during the entire period of investigation, as well as critically going through the manuscript.

I am gratified to record sincere thanks to the members of the advisory committee. **Dr. R.R. Joshi**, Department of Electrical Engineering, **Mrs. Kalpana Jain**, Department of Computer Science Engineering and **Dr. M.S. Khidiya**, Department of Processing and Food Engineering, DRI Nominee, for their generous gestures and valuable suggestions in planning and execution of this study.

I am indebted to **Dr. R.R. Joshi**, Professor and Head, Department of Electrical Engineering, College of Technology and Engineering, Udaipur for providing me facilities during the course of the investigation.

I am privileged to express a sincere and deep sense of gratitude to **Dr. Ajay Kumar Sharma**, Dean, College of Technology and Engineering, Udaipur for his due attention and encouragement during the study period and also for providing me with the necessary facilities during the course of research.

Words can hardly register the sincere gratitude and respect which I have for **Dr. N.K. Jain, Dr. Jai Kumar Maherchandani, Dr. Vikramaditya Dave** and other staff members for their kind cooperation and help as and when needed.

I am short of words to express my gratitude to my family members for their utmost co-operation, sacrifice and encouragement during the course of this work.

Place: Udaipur

Date: 16-08-2019

Yashvi Mudgal

CONTENTS

Chapter	Title	Page No.
	Certificates	
	Acknowledgement	
	Contents	i-v
	List of Tables	vi
	List of Figures	vii-x
	List of Symbols	xi-xii
	List of Abbreviations	xiii-xiv
	Abstract in English	xv
	Abstract in Hindi	Xvi
1.	INTRODUCTION	1-21
1.1	General Introduction	1
1.2	Solar Photovoltaic (PV) System	1
1.3	Power Quality	4
1.4	Harmonics	4
	1.4.1 Economic Effects of Harmonics	5
1.5	Traditional Methods of Harmonic Filtering	5
1.6	Active Power Filter and its Configuration	5
	1.6.1 Series Active Power Filter	7
	1.6.2 Shunt Active Power Filter	7
	1.6.3 Hybrid Active Power Filter	8

1.7	Advantages of Active Filter	9
1.8	Control Strategies	9
1.9	Technical and Economic Considerations	10
1.10	Selection Consideration of Active Filter for Specific Application	11
1.11	Photovoltaic System	12
1.12	Power Electronic Converters	14
	1.12.1 Boost Converter	14
1.13	Unified Power Quality Conditioner Connected PV System	15
	1.13.1 Role of DC Side Capacitor	16
1.14	Current Control Techniques	17
1.15	Current Reference Generation Technique	18
	1.15.1 p-q Method	18
	1.15.2 Direct Testing and Calculation Method (DTC)	19
	1.15.3 Synchronous Reference Frame Method (SRF)	19
1.16	Comparison of Current Generation Methods	20
1.17	Objectives	20
1.18	Outline of the Thesis	20
1.19	Closure	21
2.	LITERATURE REVIEW	22-34
	2.1 Introduction	22
	2.2 Harmonics in Power System and Active Power Filters	22

2.3	Development of the Photovoltaic System	25
2.4	Evolution of Unified Power Quality Conditioner	28
2.5	Closure	33
3.	MATERIALS AND METHODOLOGY	35-53
3.1	Introduction	35
3.2	Grid Connected PV–System without Unified Power Quality Conditioner	35
3.3	Designing and Modelling of PV Array	37
3.3.1	Modelling of Solar PV Cell	38
3.4	Designing of Boost Converter	40
3.4.1	Operation of Boost Converter	40
3.5	Inverter Configuration	42
3.6	Three-Phase System Confederated PV-UPQC	43
3.7	Designing of UPQC	45
3.8	Proposed Structure for Current Harmonics Compensation	46
3.8.1	Basic Compensation Principle	46
3.8.2	Estimation of Reference Current	46
3.8.3	Estimation of Source Current	47
3.8.4	Design of DC side Capacitor	48
3.9	Control Strategies for Shunt Active Power Filter	48
3.9.1	SRF Theory based Current Control Strategy	48
3.9.2	Hysteresis Current Control Method	51

3.10	Control Scheme Series Active Power Filter	52
3.11	Closure	53
4.	RESULTS AND DISCUSSION	54-70
4.1	Introduction	54
4.2	I-V and P-V characteristics of PV Array of Proposed System	54
4.3	Waveforms of the System without UPQC	55
4.4	Performance of PV in the presence of Installed UPQC	59
4.5	Performance of PV-UPQC Confederated System under Various Dynamic Conditions	60
4.5.1	Case I – Performance under Varying Irradiance	60
4.5.2	Case II – Performance of Confederated PV-UPQC system under Current Unbalance Conditions	61
4.5.3	Case III – Performance of PV-UPQC under Voltage Fluctuation	62
4.5.4	Case IV – At Negligible Temperature and Irradiance at 1°C and 1 W/m ²	63
4.5.5	Case V – Load is Zero and Generated Power is Continuous	63
4.5.6	Case VI – Load is Very High and Generation of Power is Continuous	65
4.6	Performance of PV-UPQC under Steady State Condition	66
4.7	Total Harmonic Distortion (THD) Calculation	68

4.8	Comparative FET Analysis	69
4.9	Closure	69
5.	CONCLUSION AND FUTURE SCOPE	71-72
5.1	Summary and Conclusion	71
5.2	Future Scope	71
	LITERATURE CITED	73-79
	APPENDIX – I	80
	APPENDIX – II	81
	PUBLICATION	82

LIST OF TABLES

Table	Title	Page No.
1.1	Global capacity of Solar energy Photovoltaic in GW	3
1.2	Role of Different Stages of Control	10
1.3	Current Distortion Limits (120V through 69kV)	11
1.4	Voltage Distortion Limits	11
1.5	Criteria for Selection of Active Filter for Specific Applications	12
1.6	Comparison of Current Control Techniques	17
1.7	Comparison of Current Reference Techniques Generation	20
3.1	Model Parameters of PV-Array Grid Connected System	37

LIST OF FIGURES

Figure	Title	Page No.
1.1	Solar Energy Percentage Share of the Country	2
1.2	Solar Global Capacity of Top Ten Countries	2
1.3	Annual Increment in SPV Global Capacity in 2017	3
1.4	Categorization of Power Quality Variation	4
1.5	Classification of APF's	6
1.6	A Series APF Scheme	7
1.7	A Shunt APF Scheme	8
1.8	A Hybrid Filter	8
1.9	Control Strategies of Active Filter	9
1.10	Criteria for Selection of Active Power Filter	11
1.11	Structure of a PV Cell	13
1.12	Classification of the PV system	13
1.13	Boost Converter	14
1.14	Continuous Conduction Mode	15
1.15	Three Phase PV-UPQC Configuration	16
1.16	Various Current Control Techniques	17
1.17	Calculation Block Diagram of the p-q Method	18
1.18	Block Diagram of Direct Current and Testing Method	19
3.1	Block Diagram of PV System without UPQC	35
3.2	Three-Phase PV System in MATLAB	36

3.3	MATLAB Model of PV Array	38
3.4	Modelling of PV Array Equations	38
3.5	Equivalent Circuit of Solar Cell with One Diode	39
3.6	Circuit Model Structure of the PV Array	39
3.7	MATLAB Model of Boost Converter	40
3.8	Schematic Circuit Diagram of Boost Converter	41
3.9	Diagram when Switch T_1 is ON	41
3.10	Diagram when Switch D_1 is ON	42
3.11	MATLAB Model of Voltage Source Converter	43
3.12	Simulink Model of Discrete PWM Generator	43
3.13	Simulink Model Three-Phase Confederated PV-UPQC System	44
3.14	Configuration of System containing UPQC	45
3.15	Synchronous d-q-0 Reference Frame-based Compensation Algorithm	49
3.16	Hysteresis Control	51
3.17	Simulink-Configuration of SRF Technique in Hysteresis Controller	51
3.18	Simulink-Configuration PLL Controller used in Series Active Power Filter	52
3.19	Internal Diagram of PLL Controller	53
4.1	I-V Characteristics of PV as Function of Temperature and P-V Curve	54
4.2	Output Current of PV Array without UPQC	55

4.3	Boost Converter Current without UPQC	55
4.4	Boost Converter Voltage without UPQC	56
4.5	Output Voltage of Inverter	56
4.6	Inverter Current	57
4.7	(a) Series Transformer Voltage (b) Waveforms of the Source Current (c) Waveforms of the Source Voltage.	57
4.8	FET Analysis of Source Current without UPQC	58
4.9	FET Analysis of Source Voltage without UPQC	58
4.10	Output Current of PV Array with UPQC	59
4.11	Boost Converter Current with UPQC	59
4.12	Boost Converter Voltage with UPQC	60
4.13	(a) Irradiance Variation (b) Temperature Variation	60
4.14	Source Current under Varying Irradiance	61
4.15	Load Current under Varying Irradiance	61
4.16	(a) Source Current under Unbalance Current Conditions (b) Injected Current from Shunt Compensator (c) Improved Current after Compensation	61
4.17	(a) Three-Phase Input Voltage (b) Compensating Voltage (c) Load Voltage	62
4.18	Voltage Source at Temperature and Irradiance at 1°C and 1 W/m ²	63
4.19	Load Current at Temperature and Irradiance at 1°C and 1 W/m ²	63
4.20	(a) Source Current at No Load (b) Injected Current by Inverter at No Load (c) Improved Current at No Load	63

4.21	(a) Source Voltage at No Load (b) Injected Voltage by Series Inverter at No Load (c) Improved Voltage at No Load	64
4.22	Simulation Data Inspector of Load Voltage and Compensated Voltage at No Load Conditions	64
4.23	At High Load Behaviour of (a) Source Current (b) Injected Current by Shunt Inverter (c) Improved Current	65
4.24	At High Load Behaviour of (a) Source Voltage (b) Injected Voltage by Shunt Inverter (c) Improved Voltage	65
4.25	Simulation Data Inspector of Load Voltage and Compensated Voltage at High Load Conditions	66
4.26	Current supplied to the Series Active Filter of UPQC	67
4.27	Voltage supplied to the Series Active Filter of UPQC	67
4.28	Load Current Behaviour in Steady State Condition	67
4.29	Load Voltage Behaviour in Steady State Condition	67
4.30	FET Analysis of Load Current of PV-UPQC System	68
4.31	FET Analysis of Load Voltage of PV-UPQC System	68
4.32	FET Analysis of Load Current (a) Before Filtering (b) After Filtering	69
4.33	FET Analysis of Voltage (a) Before Filtering (b) After Filtering	69

LIST OF SYMBOLS

μG	Micro-Grid Generation
I_{ph}	Current generated by the Solar Cells (A)
R_s	Resistance in Series (in ohms)
Ω	Ohm
R	Resistance of the Branch (in ohms)
R_p	Reactance in Parallel (in ohms)
P	The Output Power of Solar PV (in kilowatts)
N	Total Number of Modules in the SPV System
G_a	Irradiance
N_{ser}	Total Number of Modules within a Series
I_d	Diode Current
N_{par}	Total Number of Modules within Parallel
I_0	Diode's Reverse Saturation Current
T_1	Switch in Boost Converter
D_1	Diode in Boost Converter
T_c	Temperature in Cell (K)
T	Solar PV Module Temperature (in degree Celsius)
K	Kelvin
V_L	Voltage across Inductor
V_{out}	Output Voltage across Load
$V_{dc\ p-p\ (max)}$	Peak to Peak Voltage Ripple
$I_{c1\ rated}$	Rated Filter Current
d	Quadratic Axis
q	Direct Axis

$\overline{p_1}$	DC Component Real Power
$\widetilde{p_1}$	AC Component of Real Power
ω_r	Angular Velocity
V_C	Active Power Filter Output Voltage
R_{sh}	Shunt Resistance
V_{abcse}	Three-phase AC Source Voltage
rad/sec	Radian per second
Hz	Hertz
I_{abcse}	Three-Phase Current AC Source
W / m^2	Watt per square meter
I_{abc}	Load Current of Shunt Active Power Filter
V_{load}	Load Voltage of Series Active Power Filter
$I_{c(t)}$	Compensating Current provided by Active Filter
$P_{f(t)}$	Fundamental Power by the Load
$I_{s(t)}$	Instantaneous Current
V_{out}	Inductor Output Voltage
θ	Angle
3- ϕ	Three-Phase
Freq.	Frequency
V_{in}	Input Voltage of Boost Converter
$\overline{q_1}$	DC Component Imaginary Power
$\widetilde{q_1}$	AC Component of Imaginary Power
Σ	Sigma

LIST OF ABBREVIATIONS

PV	Photovoltaic
GW	Gigawatts
THD	Total Harmonic Distortion
LC	Inductor – Capacitor
APF	Active Power Filter
PWM	Pulse Width Modulation
IEEE	Institute of Electrical and Electronics Engineering
kV	kilovolt
Fig.	Figure
DC	Direct Current
AC	Alternating Current
UPQC	Unified Power Quality Conditioner
<i>et al.</i>	and others
IGBT	Insulated Gate Bipolar Transistor
MOSFET	Metal Oxide Semi-Conductor Field Effect Transistor
DG	Distributed Generator
EAR	Electrical Array Configuration
OPF	Optimal Power Flow
ATC	Analytical Target Cascaded
PSCAD	Power System Computer-Aided Design
SERC	Series Compensator
PAC	Power Angle Control
iUPQC	Dual Unified Power Quality Conditioner
SPV	Solar Photovoltaic
ANF	Adaptive Notch Filter

UPQC-O	Open Unified Power Quality Conditioner
1UPQC	Single Phase Unified Power Quality Conditioner
NCT	New Converter Transformer
PLL	Phase-Locked Loop
DTC	Direct Testing and Calculating Method
LPF	Low Pass Filter
SVM	Space Vector Modulation
SRF	Synchronous Reference Frame
SD	Synchronous Detection
VSI	Voltage Source Inverter
PID	Proportional-Integral-Derivative
STC	Standard Test Conditions
FET	Fast Fourier Transform

CHAPTER – 1

INTRODUCTION

1.1 General Introduction

According to the present scenario, fossil fuel is reported at the verge of extinction. With time, the demand for energy is increasing proportionally at an extremely fast rate and simultaneously energy cost is also rising. To overcome these difficult situations renewable energy resources are being used. In the current scenario, installation rooftop photovoltaic (PV) systems are used at various places all around the world. PV energy has a great capacity to supply pollution-free energy. PV cells convert solar energy to direct electric energy. Solar energy generation is noise-free and has a long life with less maintenance and quality outcomes. Solar Energy is considered as uncontaminated and a pure source of energy because of non-polluted behaviour.

Solar Photovoltaic system has become the centre of focus as it promotes sustainable development with global energy needs. For domestic purposes, medium size PV grid is used effectively. Increase in harmonic distortion and power electronic loads penetration have been increased with the enhancement of power electronics devices. The line current shifts path from the sinusoidal waves at the input of the diode bridge and these non-linear currents eventually results in voltage distortion and unbalanced system. Therefore, to solve these power quality problems a system can be designed to increase PV system utilization with three-phase AC voltage source.

The intended system will have the functions of power quality conditioner. Conventionally, for harmonics mitigation, passive filters were used but compensated single harmonics at a time. They were also bulky in weight. With the advancement of semiconductor devices, active harmonic filters with various current control strategies are extensively used and encouraged. Integration of the photovoltaic array with the Unified Power Quality Conditioner (UPQC) using active filters has a magnificent advantage of clean energy generation with improved power quality.

1.2 Solar Photovoltaic (PV) System

The Sun is a source of endless energy to the earth at no cost. Presently, various new technologies are used to extract energy from the sun. The Fig.1.2 depicts the solar energy status of top 10 countries contributing to the global capacity of solar energy.

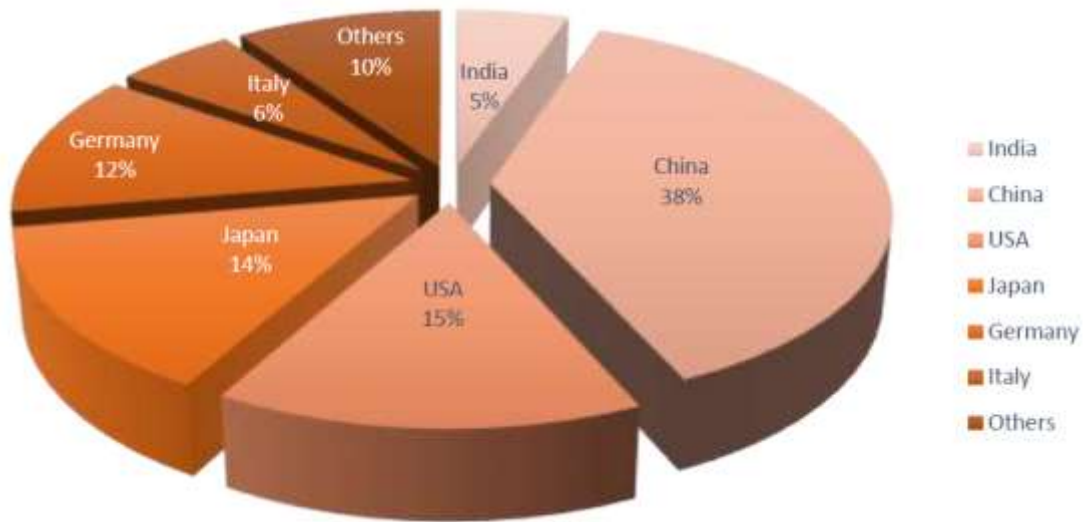

Fig.1.1: Solar Energy Percentage Share of the Countries

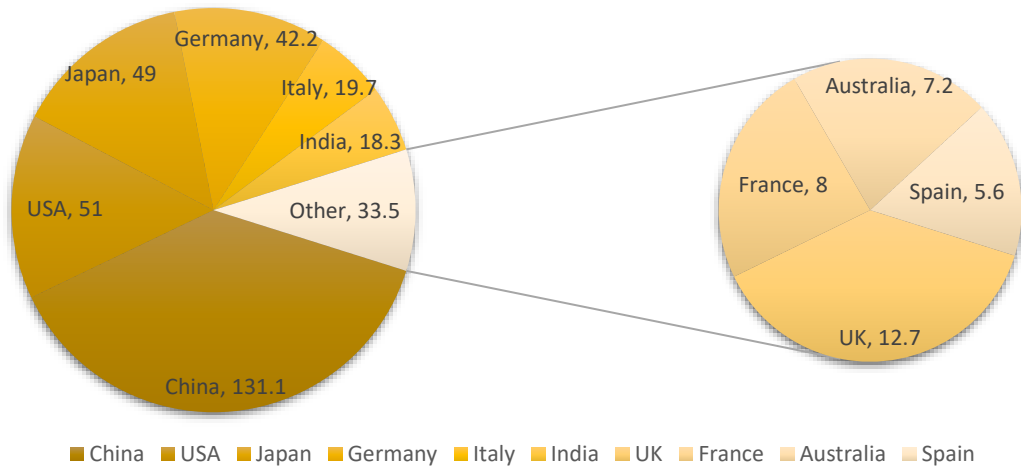

Fig.1.2: Solar Global Capacity of Top Ten Countries

China can extract the maximum of the sun's energy with 38% of the world's total solar-generated quantity of PV power. Whereas, India is contributing to 18.3 GW which is 5% and it is at sixth position among the top ten countries as shown in Fig.1.1(REN21 Renewable 2018 global status report).

Table 1.1 gives the numeric figures for global capacity for different solar energy sources (REN21 Renewable 2018 global status report) and the status of 2018 is estimated to be of 512 GW according to Report IEA PVPS T1-34:2018.

Fig.1.3 globally added Solar PV Capacity in 2017 where China, USA and India and accounted for 54%, 10.8% and 9.3% of the whole world's annual increment capacity of PV installations. In India, Telangana and Karnataka had fifty percent of the country's

latest Solar PV installations, both added more than 2GW of energy, followed by Andhra Pradesh and Rajasthan with main focus on the sustainable renewable power generation.

Telangana turned out to be the first state of India to exceed the set limitation quantity of 3GW of installed Solar PV systems which are regarded as an achievement in this developing field. Indian government declared many plans to tender the initiative of an additional 67 GW of Solar Photovoltaic (SPV) capacity by 2020.

Table 1.1: Global capacity of Solar energy Photovoltaic in GW

Year	Solar Photovoltaic (GW)
2009	22.477
2010	39.059
2011	69.599
2012	96.966
2013	134.048
2014	169.642
2015	220.284
2016	292.170
2017	384.621

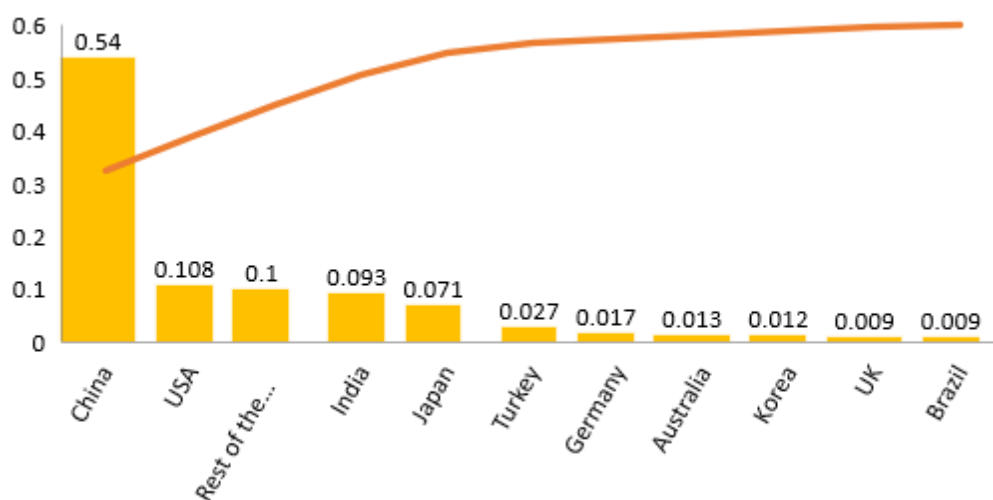

Fig. 1.3: Annual Increment in SPV Global Capacity in 2017

1.3 Power Quality

Advanced technology requires power which is distortion-less and have high attributes. Significant use of electronics for domestic as well as massive industrial processes has acknowledged the importance of power quality. The term power quality aims at maintaining the system current or voltage with unity power factor. Power quality distortion can be defined as any change in power that interferes with the normal functioning of the particular system. Better power quality has a better economic impact on consumers. Limiting the problems of system voltage degradation is necessary with the increased use of non-linear loads. The most common types of power quality variations are presented in Fig.1.4.

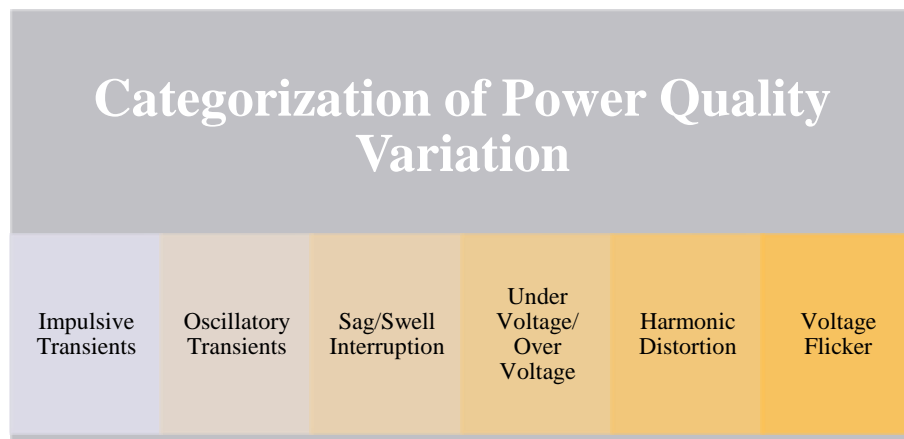

Fig.1.4: Categorization of Power Quality Variation

The symptoms such as tripping of circuit breaker without being overloaded, failing of electronic system and mis-operation of electric equipment are the indicators of power quality problems.

1.4 Harmonics

Harmonic is that frequency's component which is an integral multiple of the fundamental frequency. Harmonic distortion can be considered as pollution in the electrical system as they turn out to be a topic of major concern if it exceeds certain limits. Total Harmonic Distortion (THD) of a signal is defined as the ratio of the sum of the powers of all individual harmonic components to the power of the respective fundamental frequency. The sensitive non - linear loads which are in the influence of the corrupted quantities helps in the determination of the voltage or current distortion limits.

1.4.1 Economic Effects of Harmonics

- Premature ageing of used materials which requires replacement, in addition to an initial oversizing of these materials.
- The overloading of the grid which implies to increase the nominal power and to oversize the installations, causing more and more losses.
- The current distortions cause sudden triggers and the stop of production of power.

These materials increase the cost with the production losses thereby affecting the competitiveness and the productivity of factories and companies.

1.5 Traditional Methods of Harmonic Filtering

Shunt passive filters were used as a prevalent method for removal of harmonic currents produced by non - linear loads. Major problems associated with these filters are: they are size and cost prohibited. Another drawback is the variability in source frequency and hence harmonic content which eventually has an impact on the performance of the filter. Therefore, passive filters having the design of multistage tuned LC circuit is not ideal and thus, attenuate all frequencies.

Historically, the corrective methods for reducing reactive content at the fundamental frequency has been used with a switch in capacitor or thyristor control reactors at the grid connection.

Shortcomings of the system were the limiting control of the compensation as reactive components can only be switched in and out of the system in discrete varying quantities. The distribution system under light load conditions works under pressure as compensation networks resonate with the source impedance and introduce more of unwanted harmonics in the system. Increased severity of harmonic pollution has attracted the attention of the researchers in the field of power electronics to develop an adjustable solution to power quality issues.

1.6 Active Power Filter and its Configuration

The active filter technology has evolved with varying configuration to be matured enough to deal with compensation of harmonics, reactive power and neutral current in AC circuits. These objectives are either achieved individually in a separated manner or

combination, depending upon the specified requirements and effective control strategy which must be selected as per the needs.

Active filters are categorized into three types, two-wired (single-phase), three-wired, and four-wire three-phase configurations to meet the need of the nonlinear loads on the supply system. Active power filters (APF) can be classified based on the various phases, topologies and discrete converters as shown in Fig.1.5.

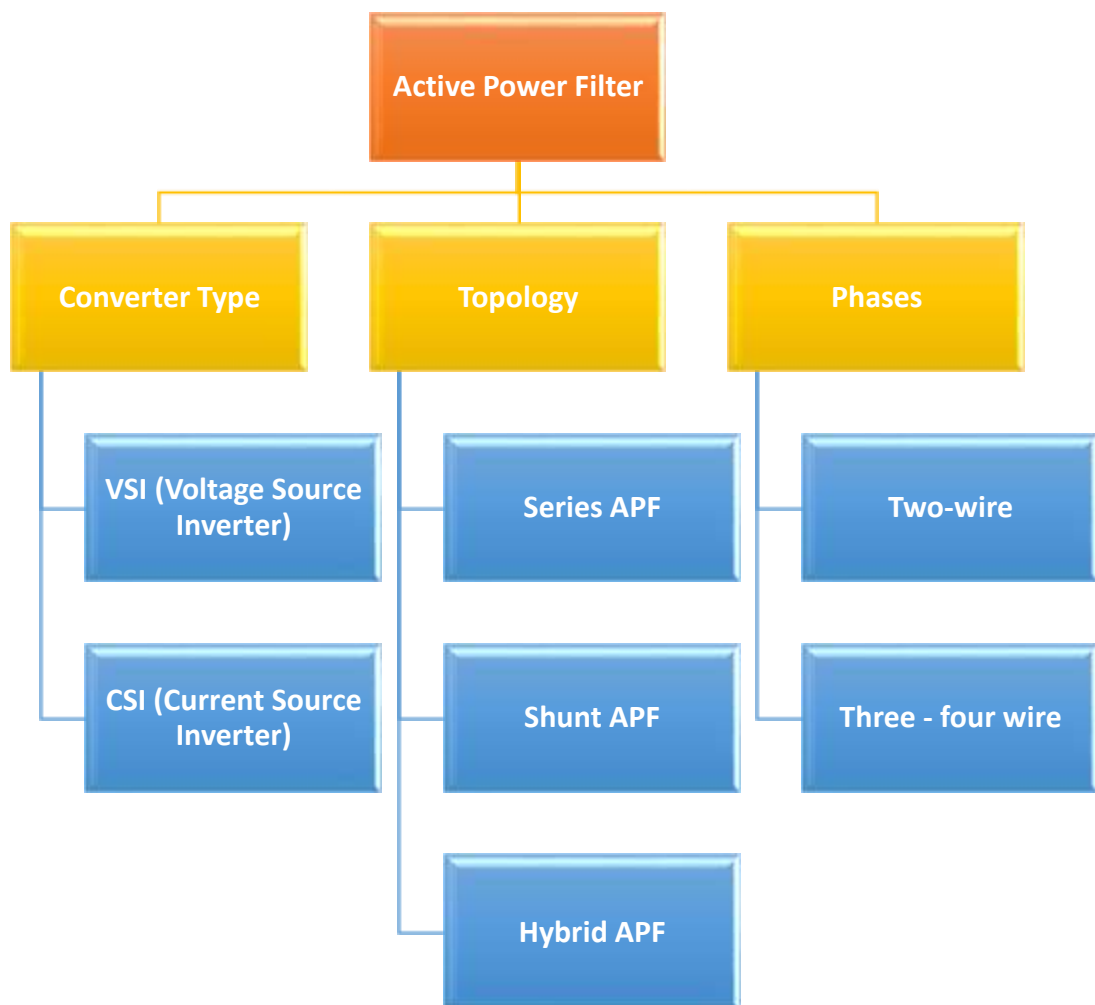

Fig.1.5: Classification of APF's

Topology based classification is described in this section as per the Fig.1.4. The filter consists of voltage source inverter with a special electronic controller which injects harmonic current on to the system 180° out of phase to the system harmonics. This results in the harmonic cancelling effect which makes the system distortion less. It is cost-effective and requires simple current control implementation methods. Inactive

filters, protection is easy as it does not require expensive and complex insulation and switchgear. A suitable controller is required to extract load harmonic current efficiently.

1.6.1 Series Active Power Filter

To eliminate voltage harmonics and to balance and regulate the terminal voltage of the loads or lines, series active power filter is connected before loading in series with the mains using a series transformer. Voltage harmonics and harmonic propagation caused by resonance with line impedance are also reduced. Thus, giving a better voltage experience. The Fig.1.6 shows the configuration of a Series Active Power filter where T is series transformer.

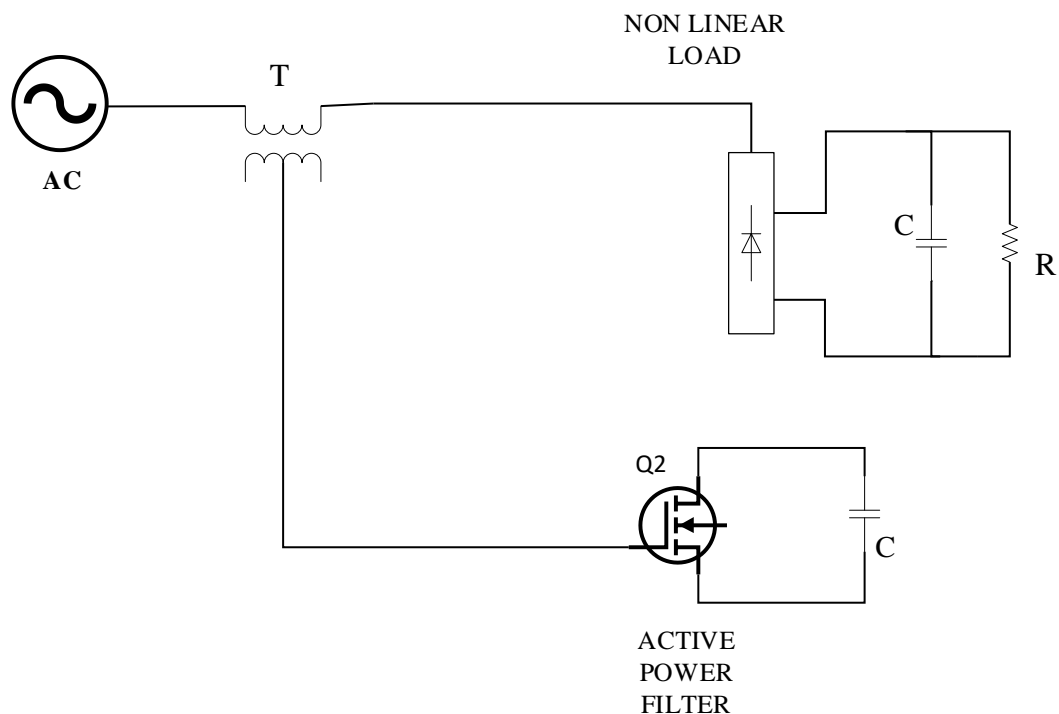

Fig.1.6: A Series APF Scheme

1.6.2 Shunt Active Power Filter

It is used to eliminate current harmonics and to balance unbalanced currents at the load end. At the point of connection, it injects equal compensating currents, opposite in phase to cancel harmonics or reactive components of non-linear load current. A Shunt Active Filter configuration is shown in Fig.1.7. The shunt filter works within the system to improve power quality at the load. Thereby, acting as a significant component of the intended system.

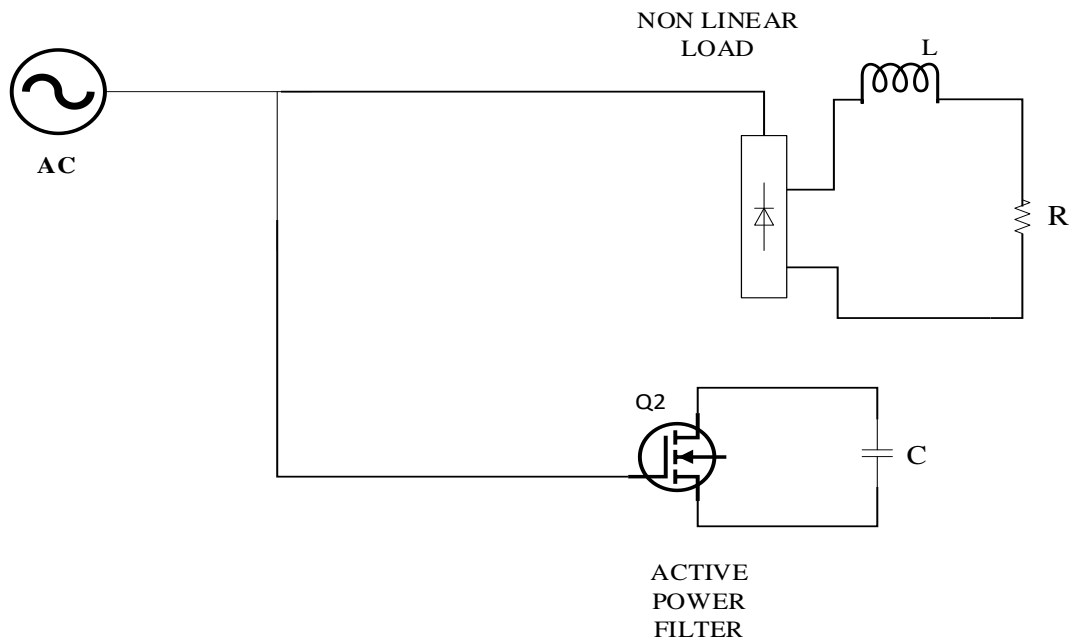

Fig.1.7: A Shunt APF Scheme

1.6.3 Hybrid Active Power Filter

The cost of static compensation is reduced by the use of combined static and passive filters. This combination is known as Hybrid Active Power Filters. Passive filter cancels the relevant harmonics while active filter improves the performance of the passive filter and cancels other necessary harmonic components. This is an efficient way to decrease the total cost. The Fig.1.8 shows the configuration of Hybrid Active Power Filter.

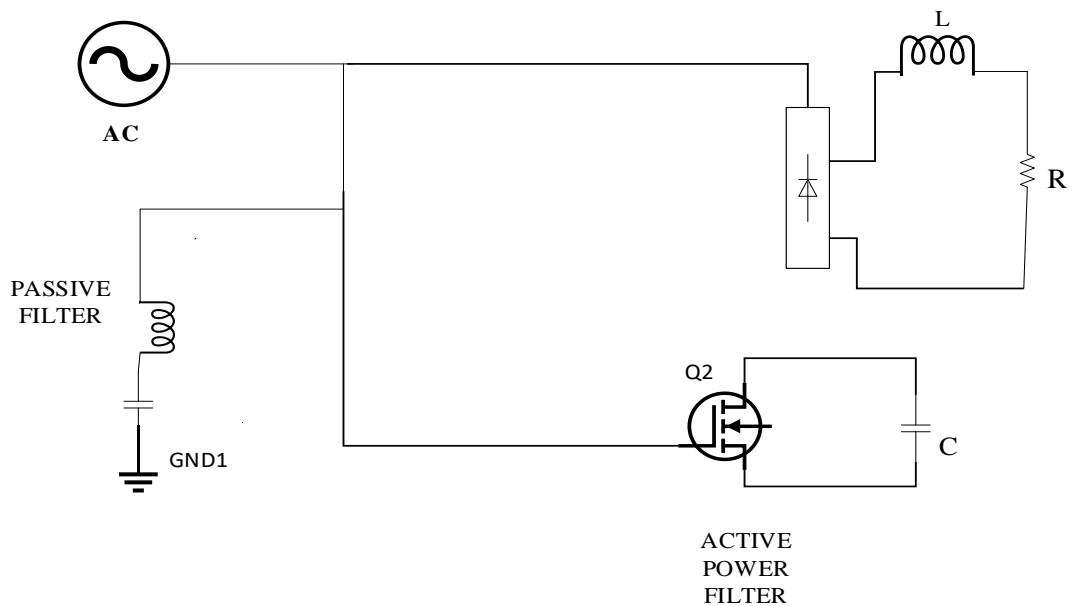

Fig.1.8: A Hybrid Filter

1.7 Advantages of Active Filter

The active filter shares many other advantages over the conventionally used methods for harmonic mitigation and they are as follows:

- Adaptation with the varying load demand.
- Possibility of selective harmonics compensation.
- Possibility of effective reactive power compensation.
- They use active devices and a resistor and a capacitor. No inductor is used.
- It requires a dual power supply and the input impedance is high.
- Parameters like gain, passband, cut off frequency can be adjusted.
- The load is isolated from the frequency determined by the network. Therefore, the variations in load do not affect the character of the filter.

Active filter suffers from high kilovolt-ampere rating. The boost converter forming the shunt active filter requires high dc-link voltage to compensate higher-order harmonics efficaciously. On the other hand, a series of active filter needs a series transformer that is capable of withstanding full load current to compensate for voltage interruptions.

1.8 Control Strategies

Control Strategy is the backbone of the active filter and has three stages of implementation. Table 1.2 demonstrates the role of the different stage of the control strategy.

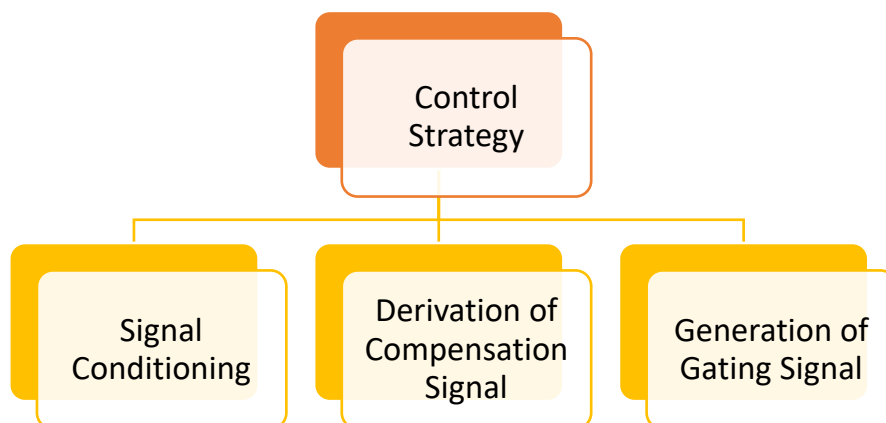

Fig.1.9: Control Strategies of Active Filter

Table 1.2: Role for Different Stages of Control

Stages of Control	Role
I	Voltage and Current Signal are sensed using Power Transformers.
II	Compensating commands are derived in terms of current and voltage levels based on active filter configuration.
III	Gating Signals are generated using PWM, hysteresis or fuzzy logic-based control techniques.

1.9 Technical and Economic Considerations

Since 1971, Technical Literature on active filter has been reported and around 1990 it boomed with many commercial developments. Active Filters are capable of compensating a very high order of harmonics and hence this approach is needed to boost field applications. Initially, economic considerations were a hindrance for active filters but now they are affordable due to the reduction of cost of devices used. Recommendation Standards such as IEEE519 will surely result in efficient use of active filter with better harmonic mitigation.

IEEE Standard 519-2014 is titled “IEEE Recommended Practices and Requirements for Harmonic Control in Electrical Power Systems.” The abstract of this standard is used today in industrial and commercial facilities for harmonics and reactive power to the various control. It covers the limit of the various disturbances recommended to the power distribution system. The 2014 standard is the revised version of earlier IEEE work published in 1992. The Table 1.3 shows the limit of individual harmonic current for distribution system where I_L is maximum demand load current at the point of the common coupling under normal load operating conditions and I_{SC} is maximum short circuit current at the point of common coupling while the Table 1.4 shows the limit of voltage distortion at different voltage levels.

Table 1.3: Current Distortion Limits (120V through 69kV)

Individual Harmonic Order(Odd Harmonics),h						
I_{SC} / I_L	Max. harmonic distortion for h					THD
	$3 \leq h < 11$	$11 \leq h < 17$	$17 \leq h < 23$	$23 \leq h < 35$	$35 \leq h \leq 50$	
$< 20^e$	4.0	2.0	1.5	0.6	0.3	5.0
$20 < 50$	7.0	3.5	2.5	1.0	0.5	8.0
$50 < 100$	10.0	4.5	4.0	1.5	0.7	12.0
$100 < 1000$	12.0	5.5	5.0	2.0	1.0	15.0
> 1000	15.0	7.0	6.0	2.5	1.4	20.0

Table 1.4: Voltage Distortion Limits

Bus voltage V at PCC	Individual Harmonics (%)	THD (%)
$V \leq 1.0\text{kV}$	5.0	8.0
$1\text{Kv} < V < 69\text{kV}$	3.0	5.0
$69\text{kV} < V \leq 161\text{kV}$	1.5	2.5
$161\text{kV} < V$	1.0	1.5

1.10 Selection Consideration of Active Filter for Specific Application

Application Requirements vary widely with requiring current voltage-based compensation.

Selection of Active Filter	FOR CURRENT BASED COMPENSATION: 1. Active Shunt Filter is used. 2. Classified as Current Harmonics, Reactive Power Compensation and Load Balancing.
	FOR VOLTAGE BASED COMPENSATION: 1. Active Series Filter is used. 2. Categorized as Voltage Harmonic Compensation, improving Voltage Regulation, Voltage Balancing, Voltage Flicker Reduction, Removing Sag and Swell.
	FOR CURRENT-VOLTAGE BASED COMPENSATION: 1. Hybrid Active Series with Active Shunt Filters is Unified Power Quality Conditioner (UPQC). 2. It is an ideal choice for mixed compensation.

Fig.1.10: Criteria for Selection of Active Power Filter

Table 1.5 shows the selection basis for evitable Active Filter for specific users and a brief list of criteria for the selection of appropriate Active Filter is described in Fig. 1.10.

Table1.5: Criteria for Selection of Active Filter for Specific Applications

Compensation for Specific Applications	Active Series Filter	Active Shunt Filter	Hybrid of Active Shunt and Passive Shunt Filters	Hybrid of Active Shunt and Active Series Filters
Reactive power		+++	++	+
Voltage Harmonics	+++		++	+
Current Harmonics		++	+++	+
Voltage Flicker	++	+++		+
Voltage Sag and Dip	+++	+	++	+
Load Balancing		+		
Voltage Balancing	+++		++	+
Active Filter Configuration With a high number of + is more preferred.				

1.11 Photovoltaic System

In this system, electric power is generated when illuminated by sunlight. The operation of the PV cell consists of the p-n homojunction cell. PV cell significantly contains a junction between two different materials across which there is a built-in electric field. The photons absorb the energy greater than the bandgap energy of the semiconductor which promotes electrons from the valance band to the conduction band. DC power is generated when the electron and hole pairs formed in the conductance band are present throughout the illuminated part of the semi-conductor.

The structure of the PV cell is shown in Fig.1.11. The basic material is used in PV cell manufacturing is either mono-crystalline or poly-crystalline silicon. Each cell is typically made up of rectangular wafers. Multiple solar cells are connected in series and parallel to produce enough voltage and power.

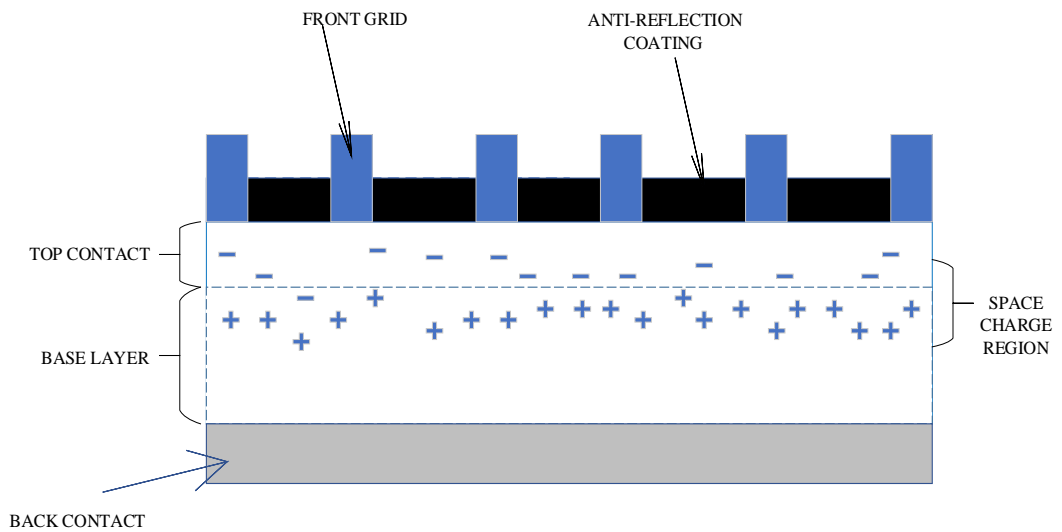

Fig.1.11: Structure of a PV Cell

The complete assembly of individual cells connected into a series string of cells is referred to as a module. The array consists of several PV modules, with electrical connections to provide electrical power having a capacity from a few hundred watts to hundreds of kilowatts.

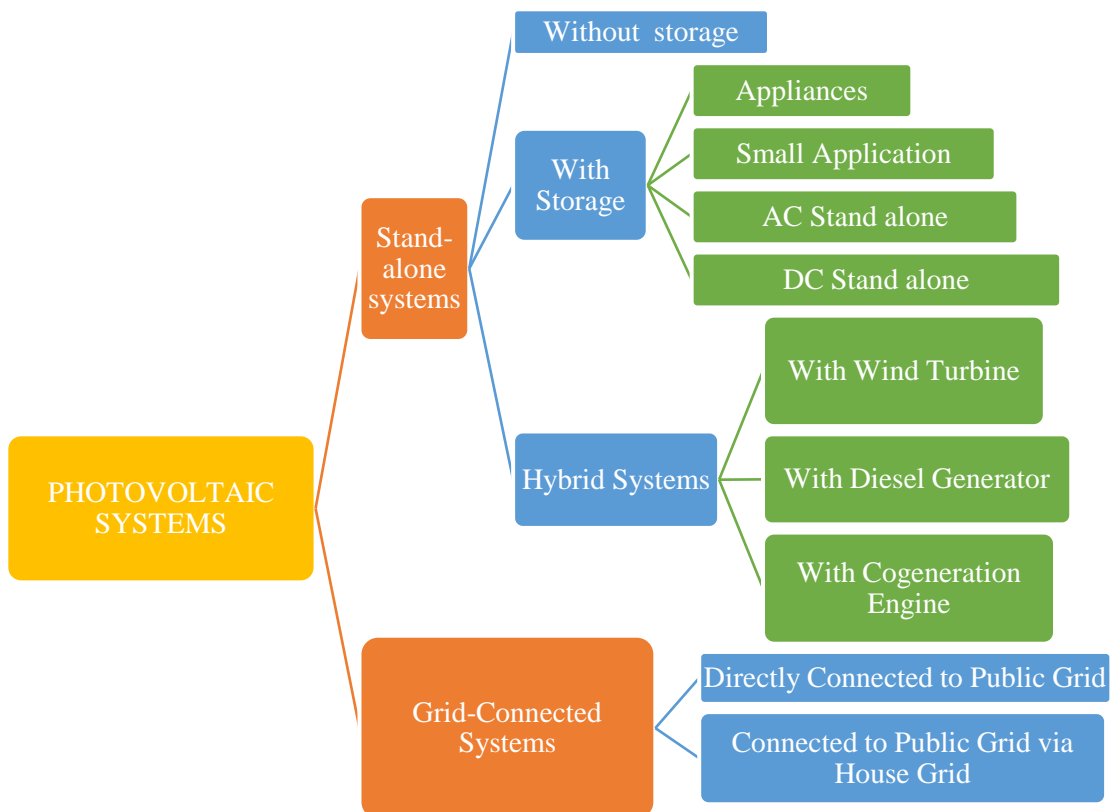

Fig.1.12: Classification of PV System

The structure of the array has four parallel connections of four module strings connected in series. The Photovoltaic systems are composed of components which are interconnected and designed accordingly to power a small device or to feed electricity into the main distribution grid. Classification of the PV system is shown in Fig.1.12.

1.12 Power Electronic Converters

When the PV system is connected to grid DC-DC converter is used between PV arrays. A DC/DC converter acts as a safety guard and a buffer which allows more freedom in selectively the nominal output voltage in PV array. For this purpose, the boost converter can be used.

1.12.1 Boost Converter

It consists of a voltage source, an inductor, a power electronic switch and a diode. Filter Capacitor is also used to smoothen the output as shown in Fig.1.13.

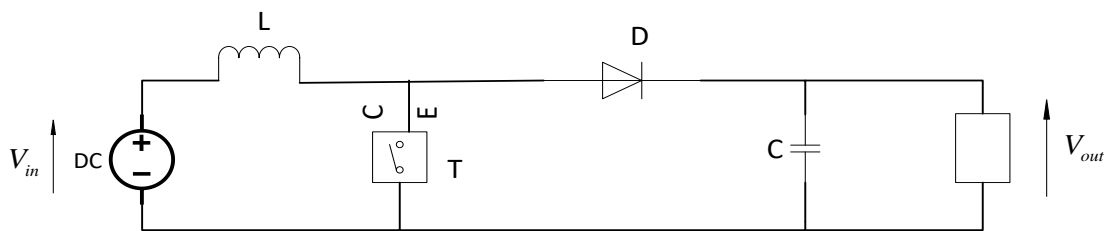

Fig.1.13: Boost Converter

Assuming a lossless circuit, $P_{in} = P_{out}$

$$\frac{I_{out}}{I_{in}} = (1-D)$$

The output voltage tends to increase with D and it is observed that the ideal boost converter is capable of generating output voltage greater than the input voltage.

In continuous conduction mode, the switch is ON for time period T to T_{on} as shown in graph Fig.1.14. The inductor current is positive and has a linear nature. V_{in} is inductor voltage. Once the switch is turned off, inductor current reduces constantly. The difference between V_{in} and V_{out} is inductor voltage. To attain continuous conduction, the voltage of the output becomes the function of the duty cycle D along with V_{in} .

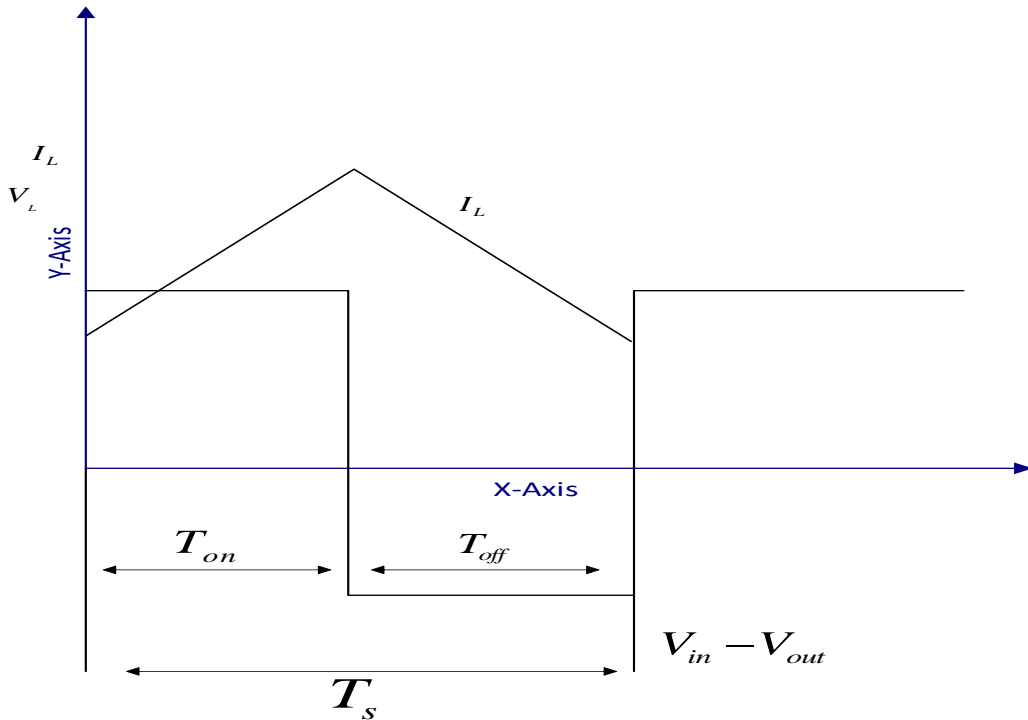

Fig.1.14: Continuous Conduction Mode

1.13 Unified Power Quality Conditioner Connected PV System

Resonance results in current and voltage distortion which is a major issue on the utility grid. Other major issues are resonance problem, over-heating, instability of the system and reactive power.

The active filter is used to mitigate these issues on the utility side. Active filters have time-dependent harmonics. There are several ways to consider to IEEE519 harmonics standard. Series active filter, shunt active filter, hybrid active filter with current source converter and voltage source converter with inverter topologies are available. The filters are sized and shaped by how much harmonic current and voltage is needed to be filtered. The electronic controller is used which injects harmonic current in the system at 180 degrees out of phase to the system harmonics.

They are cost-effective and free of power factor displacement problem. Unified Power Quality Conditioner has a simple current and voltage control implementation. It also provides immunity against an ambient harmonic load. The Three-Phase Photovoltaic and Unified Power Quality Conditioner are shown in Fig.1.15.

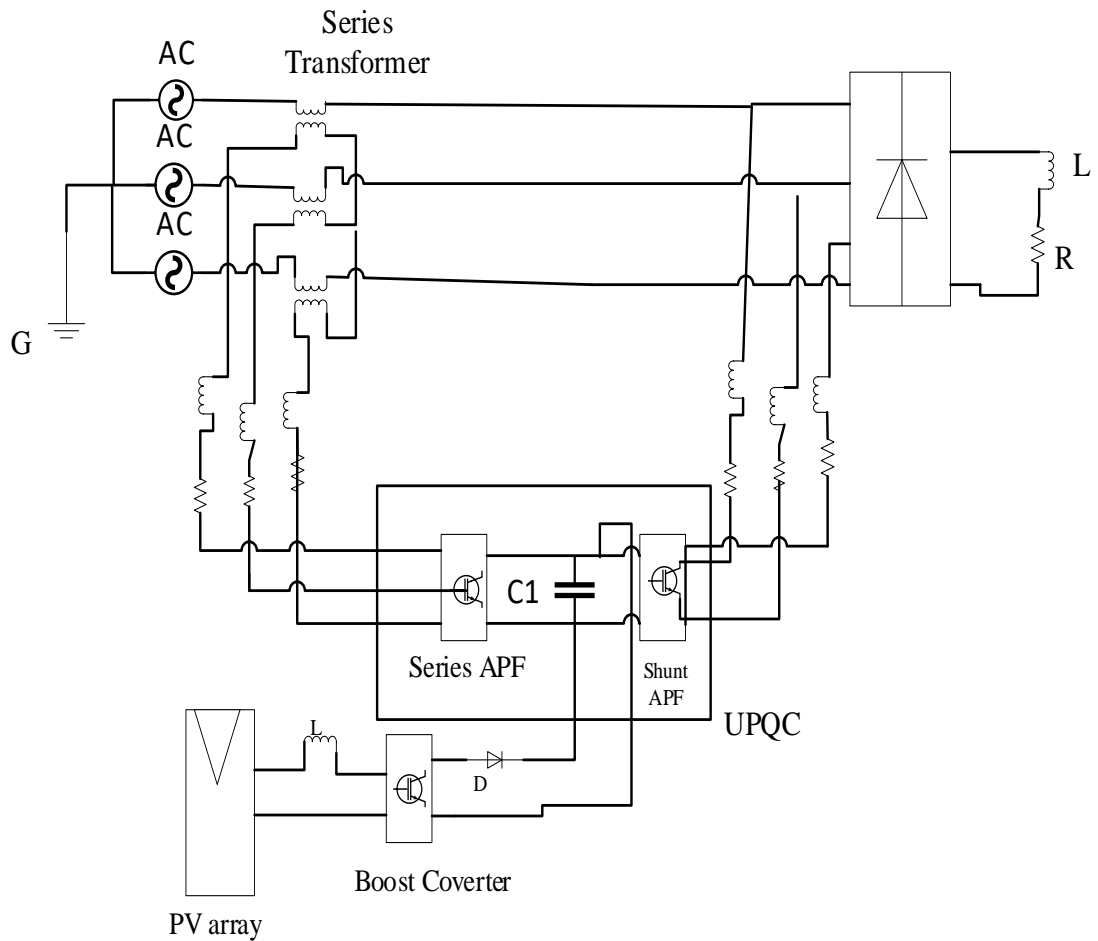

Fig.1.15: Three Phase PV-UPQC Configuration

1.13.1 Role of DC Side Capacitor

The main purpose served by the DC side capacitor are:

- (i) Maintaining DC voltage with small ripple in steady-state.
- (ii) Serving the system as an energy storage element to supply real power during the transient period.

To keep the satisfactory operation of the active filter during the steady-state conditions, the maximum point of the reference current which is considered as peak point has to be adjusted proportionally to the change in real power drawn from the defined source. The real power charged /discharged by the capacitor effectively compensates the real power consumed by the load. The defined reference source current is generated by regulating the average voltage of the DC capacitor.

1.14 Current Control Techniques

The better selection of the best current control strategy is significant for the performance of the active power filter. The capability of tracking slope variations in the current reference is essential for current control done by rectifiers to compensate distortion which makes the process critical. Therefore, the active power filter application, the choice of the current regulator with its implementation is important for the achievement of satisfactory results. The various current control methods are given in Fig.1.16.

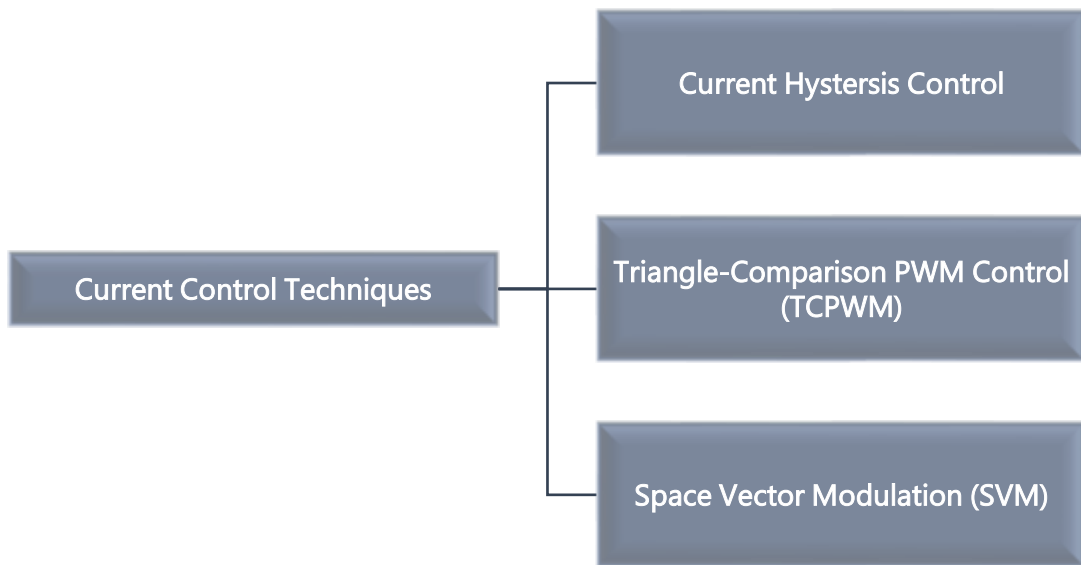

Fig.1.16: Various Current Control Techniques

The Comparison of the various current control techniques is described in Table 1.6. The control technique can be selected based on the control scheme and the specific properties which are to be applied.

Table 1.6: Comparison of Current Control Techniques

	Hysteresis Control	TCPWM	SVM
Complexity	Simple	Middle	Complicate
Speed of Response	Fast	Fast	Slow
Switching Frequency	Variable	Constant	Constant
Delay Time	No	No	Long

1.15 Current Reference Generation Technique

Selection of reference generation scheme is one of the important strategies as it determines the performance of Active Power Filter. The amplitude and phase information must be included by the current reference template for desired current compensation while the voltage across the DC bus remain constant. This scheme works adequately under steady state and transient conditions.

1.15.1 p-q Method

The instantaneous reactive power theory called the p-q theory. It can be easily applied in the control of active filter and was published in 1984. The calculation on block diagram of p-q Method is shown in Fig.1.17.

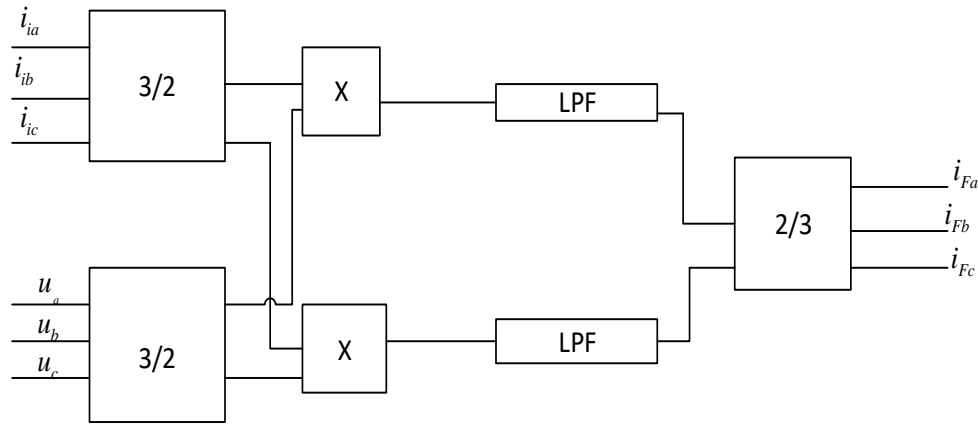

Fig.1.17: Calculation Block Diagram of p-q Method

The three-phase voltage and the three-phase load current are transformed into the static α - β frame. According to the instantaneous reactive power theory, p_1 and q_1 are decomposed into real and imaginary powers.

$$p_1 = \overline{p_1} + \widetilde{p_1}$$

$$q_1 = \overline{q_1} + \widetilde{q_1}$$

Where $\overline{q_1}$ and $\overline{p_1}$ are DC components and $\widetilde{q_1}$, $\widetilde{p_1}$ are AC components corresponding to the harmonic current. The Zero Sequence Component is neglected in the defined system and this system is not accurate and considered worthless when the three-phase system is distorted.

1.15.2 Direct Testing and Calculating Method (DTC)

The main objective of the current reference generator is to separate the harmonics and reactive components from the load current. In this method, there is no need for reference frame transformation as its basic functioning is the direct derivation of the compensation current. The Direct Testing and Calculating Method as shown in the block diagram Fig.1.18 where the distorted current is filtered to extract the fundamental components.

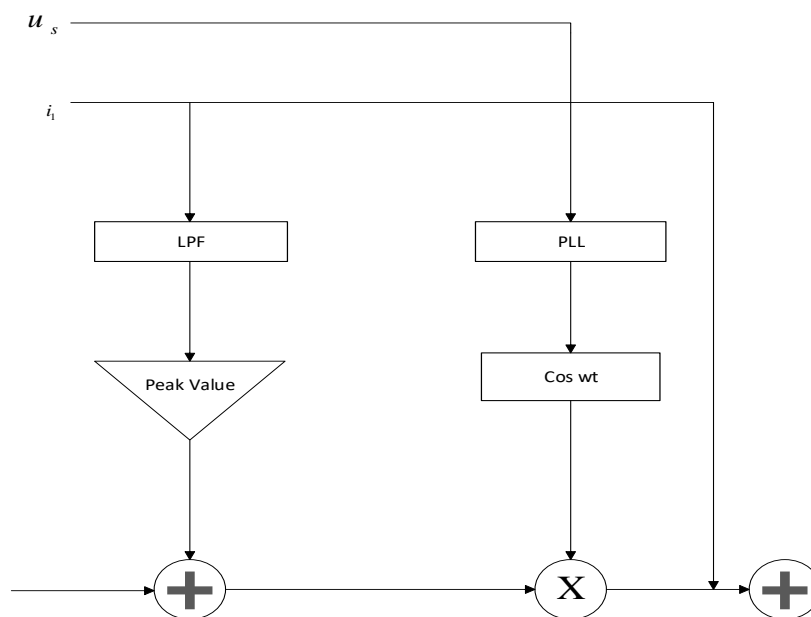

Fig.1.18: Block Diagram of Direct Testing and Calculation Method

The current signal is synchronized with the respective source voltage. The basic principle involved here is that the amplitude of the sinusoidal waveform that multiplies by the synchronous signal is equal to the amplitude of the fundamental component of the load current plus or minus the error signal. This method presents low-frequency oscillation issues in the active power filter DC voltage.

1.15.3 Synchronous Reference Frame (SRF) Method

The real currents are successfully transformed into a synchronous reference frame. The synchronous frame is synchronized with the AC mains voltage while rotating at the same frequency. One of the most important characteristics of this method is that the real load currents are used for the derivation of the reference current without considering the source voltage. The compensation of the system has robustness as its

basic property and performance of the system increases. Another specific advantage is that the reference signals are not affected by voltage unbalance.

1.16 Comparison of the Current Generation Methods

With the competitive performance, SRF is the popular method in the current reference generation in practice and Table 1.7 shows a comparison of the current generation techniques with their analysis.

Table 1.7: Comparison of Current Reference Techniques Generation

	p-q method	DTC	SRF
Harmonics Distortion effects of the Source Voltage	Yes	No	Yes
Unbalance Load Effects	Yes	No	Yes
Calculation Complexity	Complicated	Simple	Middle
With Reactive Power Compensation and Current Harmonics	No	Yes	Yes

1.17 Objectives

- 1.17.1 To develop a dynamic model of Three-Phase Confederated Solar Photovoltaic and Unified Power Quality Conditioner using MATLAB/Simulink.
- 1.17.2 To develop a control strategy for performance Confederated Three-Phase Solar Photovoltaic and Unified Power Quality Conditioner.
- 1.17.3 To analyse the performance of integrated Three-Phase Solar Photovoltaic and Unified Power Quality Conditioner under various conditions.

1.18 Outline of the Thesis

This thesis is categorized into five chapters:

Chapter-1 presents power quality problems, harmonics and their effects, various reference current generation techniques and research objectives of the thesis.

Chapter-2 lists literature review of the previously done work by the other authors.

Chapter-3 provides the mathematical modelling and detailed analysis with control

strategies of the Photovoltaic and Unified Power Quality Conditioner and its controlling techniques.

Chapter-4 demonstrates the results of the proposed MATLAB Simulink model for the Confederated Three-Phase Solar Photovoltaic and Unified Power Quality Conditioner. All the observations were analysed and recorded to determine the output of the system.

Chapter-5 covers the conclusion and future scope of the thesis work.

1.19 Closure

In recent years, harmonic pollution has become a huge problem in the distribution system, due to non-linear loads used in industrial and domestic applications. Therefore, the use of active filters helps us to have better and improved power quality. Three-phase PV-UPQC system and power qualities related to it have been studied with the possible optimal solution to design a Unified Power Quality Conditioner. Moreover, the effectiveness of the control method of the Photovoltaic and Unified Power Quality Conditioner (PV-UPQC) with the three-phase system by utilising supply voltage has been investigated.

CHAPTER – 2

LITERATURE REVIEW

2.1 Introduction

Literature survey is the base of the research thesis work as it presents ample knowledge and describes original facts about the work that has been done. It specifically covers all possible advancements until now in that field to have concise and appropriate details about the topic. This chapter presents the literature survey on Active Power Filters (APF) with harmonics in the system, Grid-connected Photovoltaic (PV) System and evolution of Unified Power Quality Conditioner (UPQC).

2.2 Harmonics in Power System and Active Power Filters

The control and energy conversion techniques involved in power electronic devices are the main source of current and voltage harmonics. In the three-phase system, the converters draw harmonics and reactive power from AC mains and can cause unbalance and excessive neutral currents. Low system efficiency and poor power factor caused by harmonics were conventionally removed by Passive Filters. But, due to several drawbacks, active power line conditioners are used effectively to mitigate harmonics related issues.

Aredes *et al.* (1997) presented a four-wire shunt active filter using three-leg converter. In this system, there is no power supply at the DC bus. The control strategy for harmonics and zero sequence components were to provide control power and sinusoidal current to the source in both balanced and unbalanced voltage conditions. These approaches were developed to control the active filter and give better Simulink results of the model.

Wang *et al.* (1997) proposed a system with the hybrid structure using a shunt Pulse-Width Modulation (PWM) active filter. The rectifier is designed which assists in handling the huge amount of the generated power. The PWM converter is utilized for harmonic elimination under various transient conditions. A suitable control scheme is also used and implemented in the rectifier and PWM converter for better dynamic response. Experimental results are recorded with better output.

Ovaska *et al.* (1998) designed a multistage adaptive filtering system which generates

the current reference accurately. The structure of the system consists of a low-pass pre-filter and an adaptive predictive filter. Active power filters are used to reduce the AC harmonic currents by injecting equal but opposite compensating currents. Therefore, the system is sufficient in compensating effectively and is applied in applications where the frequency alters rapidly. The observations were presented after experimentation and progress in of the field power electronics was documented.

Yeves *et al.* (2000) investigated the analysis of various topologies for power circuits used in power line conditioners. These circuits are specifically designed to attenuate disturbances in the system. The designing of practical equipment based on this proposed concept is also possible. The experimental results are verified and confirmed as this novel topology can be used to reconstruct the Uninterruptible Power Supply (UPS) operation in the case of a power line failure.

Kim *et al.* (2002) presented a topology of the new hybrid active power filter. In the configuration of the system, low-switching frequency but high voltage Insulated Gate Bipolar Transistor (IGBT) inverter and high-switching frequency with low voltage Metal Oxide Semiconductor Field Effect Transistor (MOSFET) inverter are used for harmonic current compensation. The IGBT inverter supports utility fundamental voltage. The MOSFET inverter assists in harmonic current elimination. DC-link is used for cost reduction and simple structure. Load Harmonics are reduced to a great extent by the use of this concept.

Chen *et al.* (2006) designed a new strategy to control by determining the reference compensation voltages of the series active power filter. This filter works under non-ideal voltage supply in the steady-state condition. The system maintains the load side voltage as sinusoidal and its simulation results were observed.

Mardina-Rios *et al.* (2007) contributed by developing Active Power Filter (APF) technique in phase coordinates which is used to reduce the harmonics generated by non-linear components in the proposed system. The control circuit is simple in structure and can be easily implemented. The case study of the system with APF is illustrated with effective operation.

Pengbo *et al.* (2007) discussed the influence of voltage fluctuation on the shunt active power filter. A small-signal model on the DC-link voltage was designed to analyse the

effects caused by supply voltage fluctuations. The feed-forward control method of voltage and current compensation is used to reduce supply voltage fluctuations and instability. This system concluded that having current control with Proportional Integral (PI) regulator eventually has excellent performance against supply voltage fluctuations.

Vitale et al. (2008) explained the single-phase Distributed Generation (DG) system collaborated with the Active Power Filtering (APF). The approach of the system is to control the DG unit. The strategy holds an idea to inject the grid current with the same phase and frequency of the grid voltage. The load harmonic in currents are also resolved successfully in the system by the alternating current system harmonic currents like those of the load but with an opposite phase, thus keeping the line current essentially linear. The notch filter has been used compellingly. Moreover, a multi-resonant current controller has been adopted and rectified as an active power filter requires current control. The proposed methodology has been tested experimentally. The stability analysis is also observed under various dynamic conditions.

Barbi et al. (2011) introduced a new technique of a single-phase rectifier followed by an inductive filter to improve the power factor. The extension of the rectifier range operation in the continuous conduction mode is signified in this system. Stimulation results are observed and defined for the system. The system has parameters such as input voltage ($220 V_{rms}$), output voltage ($200 V_d$), rated power (3 kW) and switching frequency (100 kHz). The efficiency of the system is 95% at full load which makes the working conditions highly reliable and productive from the observing end.

Akkaya et al. (2012) emphasized on shunt active filter based current source converter in which large shunt capacitors are utilized deliberately for reactive power compensation is designed to decrease the amplification of low-order harmonics between the transmission systems. The coupling transformer is also used with specially designed LC filter which helps in eliminating switching ripples. In this system, harmonic frequencies are suppressed by active damping control method. Moreover, selective harmonic amplification method is also adaptive for better outcomes. Medium voltage interface bus is used as a mobile system for suppression of harmonics in the distribution system.

Rahmani et al. (2014) proposed a system consisting of a shunt hybrid power filter and thyristor-controlled reactor for efficient system free of harmonics and reactive power compensation. Active power of small rating with LC passive filter is used as a shunt hybrid power filter. The filtering characteristics of shunt passive filter are improved by the active power filter. With filtering possibility of resonance is also suppressed effectively. For current tracking and voltage regulation, a non-linear control of active power filter is developed. A proportional-integral controller, decoupled control strategy and integral compensators are used for this revolutionary system. Satisfactory results were observed as mitigation harmonic distortion was persistent property.

Javadi et al. (2016) analyzed a transformer-less hybrid series filter with the use of sliding mode control algorithm and a notch harmonic detection technique. Single-phase distribution feeder is also included in the basic configuration of the system. The source current harmonics are compensated and reactive power regulation is also taken into consideration. The active power filter improves the power quality as voltage distortions, sags, and swells are also eliminated. Moreover, a computational delay compensation method is used to overcome the shortcomings of real-time control delay. The compensator is present to obstruct the voltage disturbances and to maintain balance in the system. The effective compensation strategy is also refined and the point of common coupling became free of voltage harmonics and voltage sag and swell.

Steinhart et al. (2018) evaluated the voltage source inverter based active power filters configuration. The proposed prototype assists in compensation of harmonic currents. The Industrial Environment is also normal for the implication of this strategy. Loads such as three-phase diode rectifiers and thyristor-based rectifiers are the typical source of the interruptions in the power system. The control technique presented in the work is to use the multiple rotating frames to get rid of harmonics with the use of an inverter-based active filter. The experimental results were evaluated and recorded in documents with majestic results under diverse conditions.

2.3 Development of Photovoltaic System

In recent years, efforts to use renewable energy as they are a sustainable source of energy has increased at a fast pace. PV generation includes large installations. It is expected that they will contribute with a significant share to power generation.

Chen *et al.* (2005) introduced active power filtering in Photovoltaic (PV) single-phase two-wire inverter system. The system removes harmonic current and helps in improving the power factor. The maximum power point tracking feature is also used in the system which eventually reduces the number of current sensors and the overall maintenance cost. Current estimator controls the inverter current. Moreover, non-linear inductance was determined by self-learning algorithm which helps in increasing the accuracy of the estimated current. Results of simulations and experimental results have affirmed the practicality of the introduced system and the used algorithm.

Alonso *et al.* (2006) illustrated issues related to integrated Photovoltaic (PV) system and related losses in electricity production. The partial shadows, variations in current-voltage (I-V) characteristics of PV modules are the main causes of the generated concerns. The orientations and inclinations of solar surfaces widely vary with different temperature effects and changing irradiance. The proposed system has intelligent PV module concept having low cost and high efficiency. Maximum power point tracking and power line communication system is highly advanced and popular. The operation and topology of the boost converter are examined. Power line communication is feasible and is used in every PV module. This system is designed to evaluate significantly various types of the PV system and considered reliable after experimentation.

López *et al.* (2009) introduced the photovoltaic generator with a dynamical Electrical Array Reconfiguration (EAR) strategy connected to the grid. To improve the production of energy and have a sustainable resource, this system is considered effective as sometimes the operating conditions of the solar panels are different and unpredictable. The EAR strategy has controllable switching matrix installed between the PV generator and the central inverter, which allows the electrical proper connection with PV array. The result shows the proposed system exhibits a self-capacity for real-time adaptation to external and vivid operating conditions of a PV generator. Simultaneously, improved energy extraction can be observed and illustrated.

Ramaswamy *et al.* (2013) considered the configuration of the Solar PV generation. The scrutiny of scenario facilitates decreasing the number of switches that were required to be installed. The intermittency of Solar PV generation made the system feasible with the adoption of the Solar PV generation technique. Non-dominated sorting

genetic algorithm efficiently assists in preparing non-dominant solutions. By the end of the analysis, the best working solution is selected depending on the needs to fulfil the desired requirements.

Alam et al. (2014) investigated that online analysis tools can be used to reduce solar Photovoltaic (PV) impacts in the distribution grid. Due to rising penetration level of power generation resources, accurate information for better decisions making is considered crucial. These online assessment tools assist in managing PV impacts on a real-time basis and also resolves fluctuating behaviour as per consumers demand. The approach is based on real-time network data with an online assessment of rooftop PV impacts having low voltage. The variable-width sliding window with Australian Low Voltage (LV) distribution feeder is used for convenience and better results as the width of the sliding window can be varied according to user input. Experimental results validate the proposed approach of the defined system.

Karimi et al. (2016) expressed that solar energy had developed altogether in the past few years and also explained that Solar PV penetration has a significant role in renewable energy sources. They are being utilized at a worldwide scale. The work asserted that the Solar PV penetration is harmful to the system as many issues are created which affects consistency and coordination of the distribution system. A comprehensive review has also been discussed on the issues such as voltage imbalance, harmonics, voltage fluctuations and their impacts on the system. Moreover, the critical significance of stability and durability of the distribution system is extensively inspected and various islanding methods and local strategies were studied to be discussed.

Yao et al. (2016) explained the impact of reverse power flow from the households to the substation when the power generation from PV units installed at rooftops is larger than the load. Voltage imbalance and voltage rise problems can be seen. Demand-side management with autonomous energy consumption scheduling algorithm is studied in the proposed system to mitigate these problems of reverse power flow. The specific stochastic programming is also used to derive an energy consumption scheduling problem. Experimental numerical result shows a reduction of voltage rise problem in regions of high penetration and the additional feature of monetary cost is observed. The cost-effectiveness is required for energy consumption with shifting of deferrable loads

to hours with high power generation. This feature is efficient and experimental results were impressive.

Quan *et al.* (2017) examined the loading of network elements and power losses due to high PV penetration in the distribution system. The challenge to voltage management by mitigating active interruptions is discussed in the proposed work. The component protection system seems to produce reverse power flow due to high Solar PV penetration which is required to be nullified. The work presented mathematical expression of penetration, system indices such as feeder voltage, power loss and network loading which were influenced by Solar PV penetration and power reversal. Furthermore, the highest possible Solar PV capacity and critical point of maximum penetration were studied and examined to generate the required results.

Natarajan *et al.* (2018) presented multilevel decentralized Optimal Power Flow (OPF) in three-phase for large distribution systems so as to have power loss minimization. The optimal reactive power scheduling and distributed sequential coordination scheme for Photovoltaic (PV) generators were also proposed in the system. An Analytical Target Cascading (ATC) method is developed to minimize power losses. Effectiveness of the system is determined by reactive power control analysis. A virtual feeder is used which assists in resolving optimization problems with minimum computational complexity. The designed system provides a faster solution and efficient results.

2.4 Evolution of Unified Power Quality Conditioner

To have effective power quality improvement facilities for reduction of harmonics the use of Unified Power Quality Conditioner is an efficient method. The improved power is used after conditioning. The Photovoltaic system integrated with power quality conditioner is thus implicit and productive.

Fujita *et al.* (1998) emphasized on Unified Power Quality Conditioner (UPQC), which is a combination of the series and shunt active power filters. The main purpose of a UPQC is to catch up on for voltage imbalance, voltage fluctuations, reactive power, negative-sequence current, and harmonics. In alternative words, the UPQC has the capability of nourishing the power quality of the system at the suggested point of installation of specific power distribution systems or the industrial power system.

Han *et al.* (2006) examined the outcomes of a combined operation of the Unified Power

Quality Conditioner with the commonly used distributed generation. The planned system consists of a series inverter, a shunt inverter with a distributed generator connected in the DC link. The system removes the voltage sag and swell, voltage interruptions, unwanted harmonics, and a huge amount of reactive power present in every interconnected mode. The operation of the proffered system was analyzed through simulations with PSCAD. The suggested UPQC model is flexible has the ultimate capability of improving power quality.

Dubey *et al.* (2008) described the Unified Power Quality Conditioner (UPQC) as efficient power electronic device having custom power solutions. It is capable of decreasing the effect of supply voltage sag at the load end in a distributed network. It is also used in mitigation of load current harmonics and therefore, improves the input power factor of the load. The Control of Series Compensator (SERC) of the UPQC is an important component. Zero active power is consumed by the SERC at steady-state conditions. The employed UPQC system is known as UPQC-Q as quadrature voltage is injected in series in the adopted configuration. The experimental and simulation results with the control block diagram of the performance new hybrid control system of the UPQC-Q are presented to confirm the validity of the theory.

Mokhtari *et al.* (2009) suggested a unified power quality conditioning system known as MC-UPQC. The most important property was simultaneous compensation for voltage and current in multi-bus systems. The shunt Voltage Source Converter (shunt VSC) and two or more series voltage source converters were used as a basic configuration. The load current imperfections and voltage interruptions were reduced. A common DC link capacitor is used to connect the converters to the DC side. Therefore, power quality is improved. The performance verification of the MC-UPQC with the synchronized control algorithm is evaluated by simulation.

Khadkikar *et al.* (2011) introduced the Unified Power Quality Conditioner (UPQC) with the concept of optimal utilization. The series inverter controls the simultaneous voltage compensation and distortions at load due to reactive power which is an important part of the UPQC configuration. The theory of Power Angle Control (PAC) of Unified Power Quality Conditioner was used with the active power control approach. The concept of the series inverter simultaneously delivering active and reactive powers is known as UPQC-S (S for complex power). Simulink results were presented in favour

of the notion. The digital signal processor-based experimental study approved the suggested concept.

Zare et al. (2013) emphasized on the utilization of Unified Power Quality Conditioner (UPQC) is to alleviate voltage quality with power circulation problems at the load side of the system. The voltage rises issues along-side of the distribution feeder decrease significantly in the system with less power imbalance problems. Mode of operation of UPQC is highlighted through simulation results analysis and results are validated by using MATLAB and PSCAD.

Khademet et al. (2015) showed UPQC (Unified Power Quality Conditioner) in Distributed Generation (DG) for the integration and control based on micro-grid generation (μ G) system. The shunt part of the UPQC (APFsh) and distributed generators are at the point of common coupling. The storage system is connected with the DC link. The voltage harmonics, voltage sag-swell and reactive power compensation are the various advantages of the system. The reconnection technique and islanding detection were introduced as a secondary control. The shunt part of UPQC offers harmonics reduction with reactive power compensation. The simulation results of the defined system were evaluated and better power quality was recorded.

Borseet et al. (2016) created a study based on the operation of the power quality conditioner connected to non-linear loads. This electrical network assists in power quality improvement. The system is feasible and provides voltage modulation for the loads and low current harmonic distortion. The dual topology of UPQC is employed as both shunt and series active filter are used. The iUPQC has the series filter as a sinusoidal voltage source and the shunt filter managed as a sinusoidal voltage source. The Pulse Width Modulation is also used as iUPQC controller. Sudden load changes are expected in the system. Power quality improvement and mitigation of distortions are done with the developed dual UPQC (iUPQC).

Chandra et al. (2016) presented an energy conversion system which consists of Solar Photovoltaic (SPV) with an ANF (Adaptive Notch Filter) based control algorithm. This three-phase SPV system converts DC-power from SPV to AC mains with the help of an inverter. The reactive power compensation and reduction in current harmonic distortion are few of its various advantages. The capital investment in less as it has a multi-functional property in the defined range of utilised resources. The grid interfaced

SPV energy conversion system is capable to work in less space and with minimum maintenance cost. The control algorithm is used effectively to have better efficiency and adaptive quality. The experimental results declare the system as valid under various conditions. The transient and steady-state performances are evaluated and the THD (Total Harmonics Distortion) of grid currents are recorded and compared with the IEEE519 standard of the system working under non-linear load conditions.

Mohan *et al.* (2016) described the operation of the Unified Power Quality Conditioner. The shunt inverter, series inverter, and a distributed generator are used as important components of the system. The generator and the DC link are connected by the rectifier. Harmonic interruptions voltage sag-swell, reactive power is compensated by the power flow control provided by UPQC. The significant use of The Unified Power Quality Conditioner (UPQC) is to reduce the disturbances that cause an imbalance in the performance of the system. Energy storage was not taken into account with the basic structure of the system. The execution of the simulation results in MATLAB confirmed the improvement of power quality at the point of installation.

Devassy *et al.* (2017) developed a Solar Photovoltaic array combined with Unified Power Quality Conditioner (PV-UPQC-S). The system has modified p-q theory based-control. To generate reference grid currents exaction of the fundamental frequency positive sequence voltages is done. Active load power is provided by PV array of the UPQC which is integrated at the DC bus. The performance of the proposed system is verified by the simulation result using MATLAB with a combination of the linear and non-linear load.

Kadam *et al.* (2017) focused on the importance of using Unified Power Quality Conditioner (UPQC). Both current and voltage distortions were simultaneously reduced at the load side of the system. The current and voltage balance is developed at the load side. One of the advantages of UPQC is to match DC link voltage which is common for both active power filters. The switching losses are reduced by the use of the three-leg voltage source inverter. A simulation study is evaluated and documented with mitigated harmonics at the load side.

Singh *et al.* (2017) investigated the detailed performance of a three-phase solar Photovoltaic (PV) integrated with UPQC. The proposed system has a shunt and series-connected compensators components connected in order with a common DC link. It is

the combination of every advantage present in distributed generation with descriptive active power filtering. The shunt compensator of the PV-UPQC is used for the load current harmonics mitigation with reactive power compensation whereas the series compensator removes the grid side power quality issues like grid voltage related problems such as unwanted fluctuations. Better quality power with the advantage of being clean energy is the special quality of the introduced system. The dynamic performance of the proposed system is simulated in MATLAB-Simulink under a nonlinear load under various conditions such as load unbalancing and irradiation variation.

Dash *et al.* (2018) emphasized on the working of the photovoltaic systems having single-phase Unified Power Quality Conditioner (PV-1UPQC) which is based on notch filter novel control algorithm. This grid integration system is very useful and has various functions such as improved phase detection, voltage sag, voltage swell, voltage and current harmonics elimination. The Phase-Locked Loop mechanism is used to avoid multiple zero crossings. The Features like phase detection and perfect grid synchronization were used to normalize voltage and current perturbations. The experimental results developed in the laboratory using DS1103dSPACE processor evaluate the effectiveness of the introduced idea for various operating conditions in the field of power electronics for power quality improvement.

Ganguly *et al.* (2018) scrutinized the modelling for open unified power quality conditioner (UPQC-O) integrated photovoltaic (PV). The generation system had radial distribution networks to improve energy efficiency. A UPQC is an electronic device which is defined by the simultaneous working of series and shunt inverters. The position of these inverters varies widely in the system network. UPQC-O with battery and PV array (UPQC-O-WB) and UPQC-O with only PV array (UPQC-O-WOB) are the two types of the model proposed for the better results. Energy storage property is available in UPQC-O-WB to utilize the stored energy whenever required basically at the peak hour. The operational parameters such as bus voltage are determined as the designed model is incorporated in the forward-backwards sweep load flow. An optimisation problem is planned and an objective function is included for investment and operational costs of inverters, battery and PV array. The particle swarm optimisation assists the proposed system and provides a better working environment. Fluent analysis after modelling in MATLAB is done for power quality improvement.

Kumar et al. (2018) deal with the Unified Power Quality Conditioner (UPQC) with a New Converter Transformer (NCT) to provide compensation in the transmission and the distribution system. The objective is to eliminate the current and voltage distortion problems. NCT has a typical wiring configuration. To connect compensating devices a linking point is available in between two winding. Power quality is maintained by the shunt and series active filter working together for a better and efficient system. The comparative analysis is done between the performance of NCT with UPQC and conventional shunt active filtering method and results are evaluated.

Bacon et al. (2019) suggested a single-stage Photovoltaic (PV) and a Unified Power Quality Conditioner (UPQC) model with a multifunctional three-phase Distributed Generation (DG) system. The analysis of stability is done through the series and parallel power converters. The DG-system is used to make the operation of UPQC as bidirectional interface and it performs the function of active power-line conditioning. Proper understanding of the designed PV-UPQC is essential involving the study of power flow to design best quality converters. The series and parallel inverters are presented and discussed in the mentioned system. The experimental results are assessed under the static and dynamic conditions with the PV-UPQC grid-connected or grid-islanded operating system.

Das et al. (2019) evaluated the use of Unified Power Quality Conditioner (UPQC) in the distribution system. The UPQC employed in the grid is capable of handling increased harmonic currents due to its limited current rating. With current harmonics mitigation and voltage, sag-swell is also reduced effectively. For the advancement of the performance of the shunt converter better technique to prioritise sag/swell compensation over active filtering is recommended in this study. Harmonic filtering is its significant feature. Adaptive determination of harmonic compensation current is used as a scheme or the efficient method to mitigate several specified harmonics at the first step of filtering. The experiment is performed at MATLAB-Simulink platform and results of single-phase UPQC is validated with improvement in the power quality in the most effective way.

2.5 Closure

The literature review shows that power quality improvement is a major concern and numerous quality work is done in this field. The area of power quality improvement

techniques using different types of active filters such as unified Power Quality Conditioner in three-phase PV configuration under various conditions and how it affects the power system and THD (Total Harmonic Distortion) percentage is studied and evaluated in the upcoming chapters. This chapter provides the base for the deep learning and effective knowledge of integrated PV-UPQC system to prepare a better version. The proposed method will help in improving power quality with renewable solar energy taken as a source.

CHAPTER – 3

MATERIALS AND METHODOLOGY

3.1 Introduction

Mathematical modelling is a well-known concept to express the design or model of any practically apparent idea. The MATLAB-Simulink model with mathematical equations and formulas are presented in this section which is considered in designing of the proposed system. This chapter comprises of the mathematical modelling of the photovoltaic solar array, boost converter and integrated Unified Power Quality Conditioner (UPQC). The system configuration with and without UPQC is demonstrated with the help of MATLAB model. UPQC having shunt and series active filter is connected to the grid for providing harmonic suppression by mitigating current and voltage interruptions. This chapter also discusses the modelling and design of series and shunt active filter with a controller for switching signal generation.

3.2 Grid-Connected PV-System without Unified Power Quality Conditioner

The block diagram shown in Fig.3.1 consists of PV array, DC-DC Converter, DC – AC Inverter and utility load. It is the fundamental structure of the system.

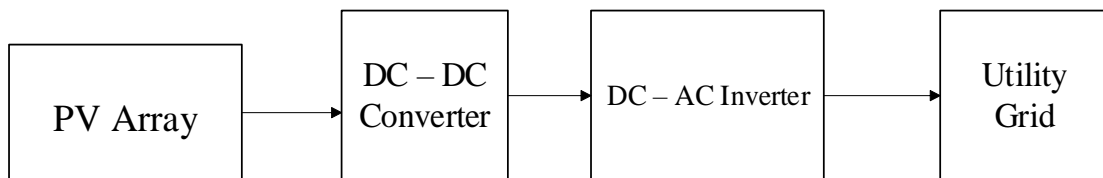

Fig.3.1: Block Diagram of PV System without UPQC

The photovoltaic (PV) array system with the utility grid is shown in Fig.3.2. The composed system mainly consists of PV array, Boost Converter and Voltage Source Inverter integrated with the three-phase voltage source and load.

In the defined system, already designed PV array module was used. As MATLAB 2018b has this specially designed PV array in its library. Physical parameters can be controlled manually and used accordingly.

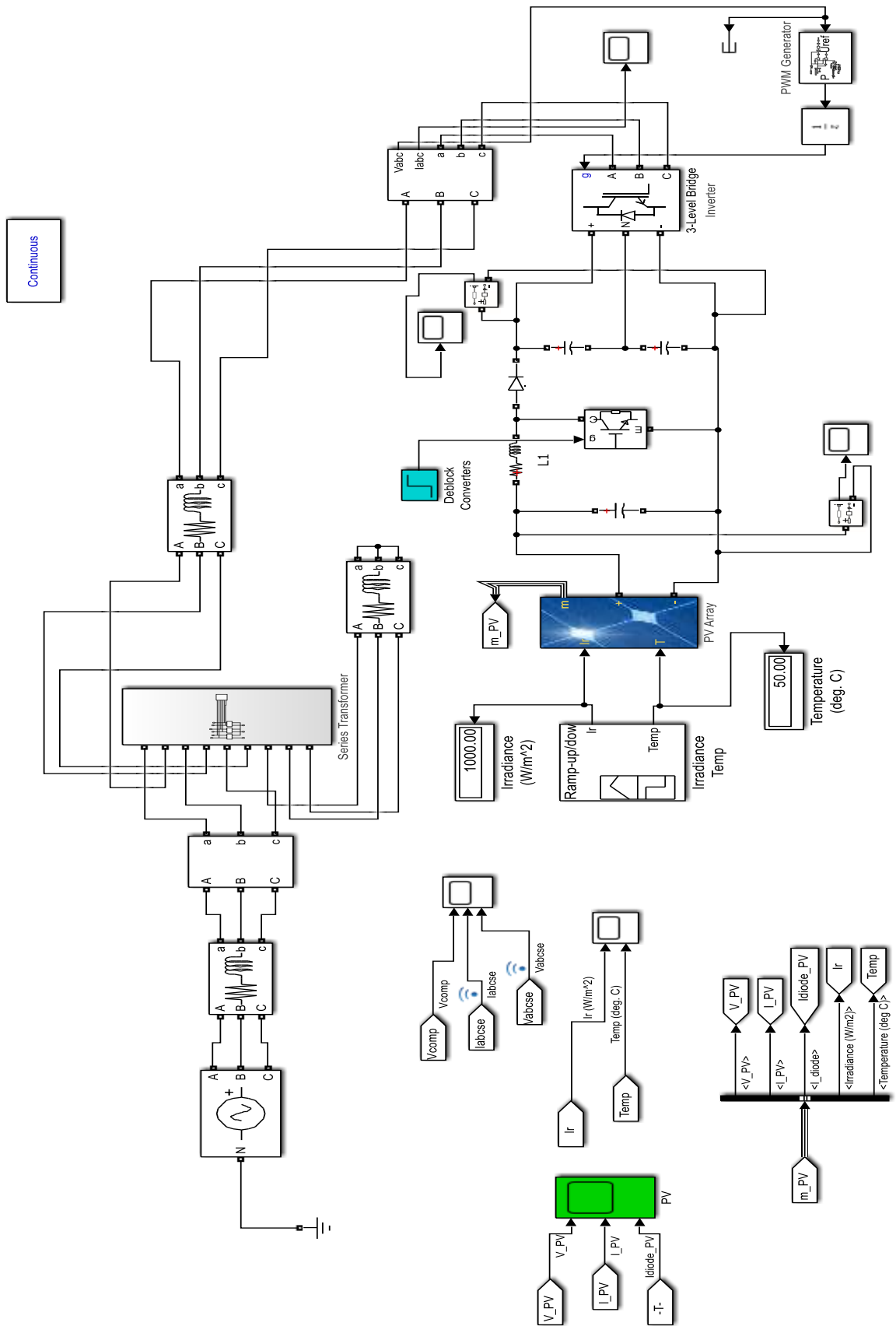

Fig.3.2: Three-Phase PV System in MATLAB

3.3 Designing and Modelling of PV Array

This system of PV array is working at Standard Test Conditions (STC) i.e. at 1000 W/m^2 and Temperature 25°C. Other Parameters of the presented system is given in Table 3.1. The PV array is a series and parallel combination of PV module. In this project, the photovoltaic array is developed and simulated as shown in Fig.3.3. The PV array has 4 parallel strings and 10 series-connected modules per string.

Table 3.1: Model Parameters of PV Array Grid-Connected System

Datasheet Parameters (DTC)	
Short-circuit current I_{sc} (A)	8.9
Open circuit voltage V_{oc} (V)	37.8
Maximum Power (W)	250.1
Current at maximum power point I_{mp} (A)	8.2
Voltage at maximum power point V_{mp} (V)	30.5
Model Parameters	
Light-generated current I_L (A)	8.92
Diode saturation current I_0 (A)	$9.91e^{-11}$
Diode Ideal factor	0.97
Shunt resistance R_{sh} (ohms)	122.53
Series resistance R_s (ohms)	0.34

Modelling of PV array in MATLAB and PV Array Equations in Fig.3.3 and Fig.3.4 respectively. The model has I_L , Diode R_{sh} , I_{PV} , V_{PV} , I_{Diode} , Irradiance and Temperature as its working input components. The PV array Module with the presented specification is present in MATLAB 2018b library.

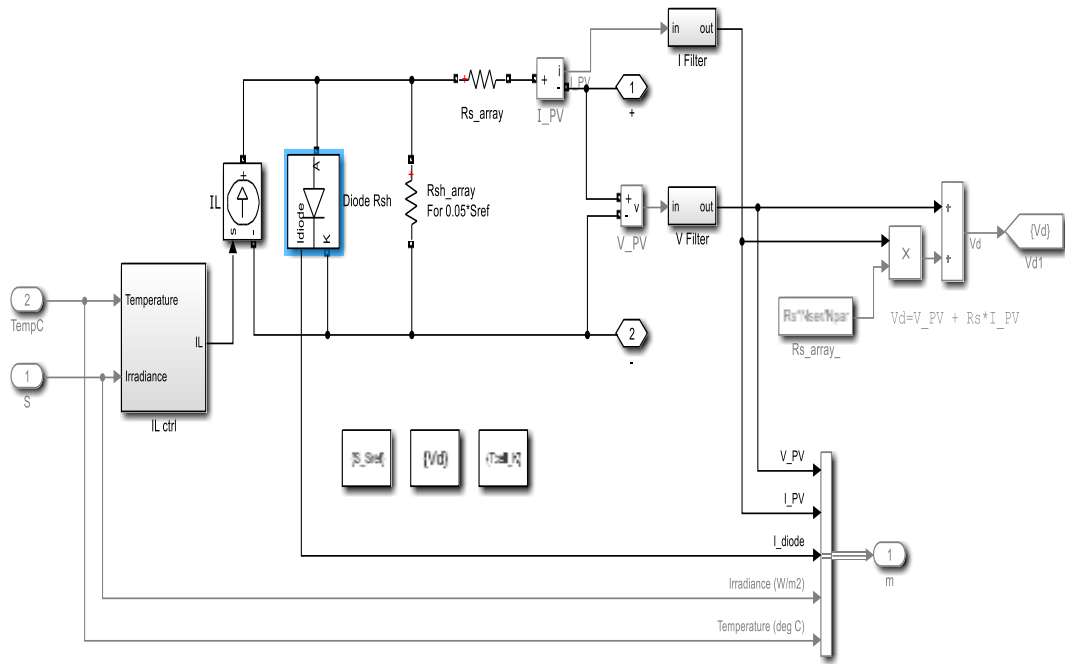

Fig.3.3: MATLAB Model of PV Array

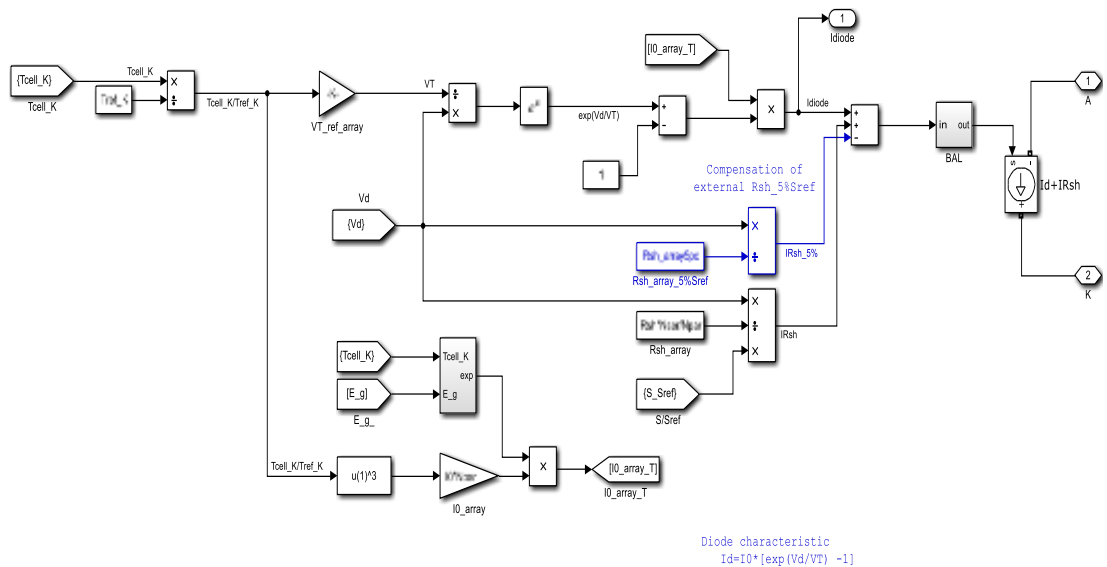

Fig.3.4: Modelling of PV Array Equations

3.3.1 Modelling of Solar PV Cell

PV cell is the unique semi-conductor device that transforms sunlight into electrical power and its structure consists of a p-n intersection. To form a desired P-V array, several PV modules are connected in series and parallel in a peculiar pattern. Eventually, the mathematical model of the PV array contains information about utilized PV cells. A well-maintained PV cell attains one diode, Resistance series and also resistance parallel connected in a particular pattern.

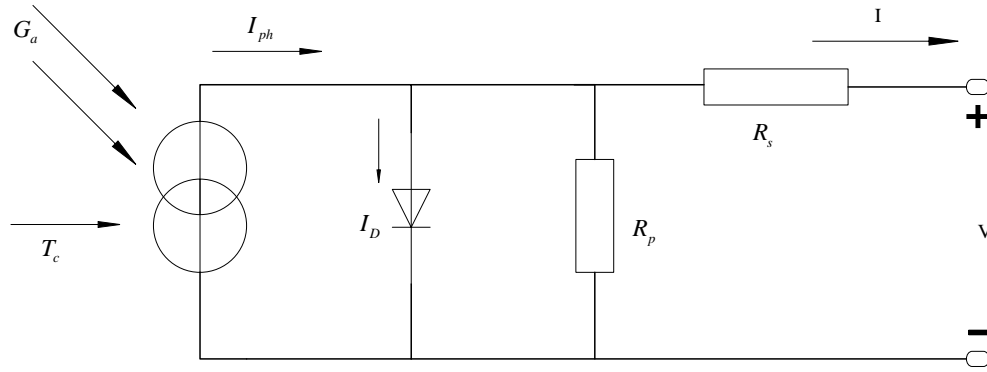

Fig.3.5: Equivalent Circuit of Solar Cell with One Diode

The various characteristics parameters of a PV cell shown in Fig.3.5 are as follows: I_{ph} define current generated by the solar cells (A), R_s is for resistance series(Ω), R_p is for resistance parallel(Ω), Irradiance is denoted by $G_a(W/m^2)$, T_c is for cell Temperature(K) and I_D stands for diode current.

Firstly, Solar cell is modelled then it is extended to the solar module and finally modelling of the PV array is done. The Fig.3.6 shows a PV array, which consists of multiple modules, linked in series and parallel where N_{ser} is total number of the module within series and N_{par} total modules connected parallel. In the equation, given in Fig.3.6 I_0 is diode's reverse saturation current and a denote diode quality factor between 1 to 2 and it's usually 1 in case of the ideal diode. The PV array will be stimulated with the given equation. Current-Voltage relation of the PV array is as follows:

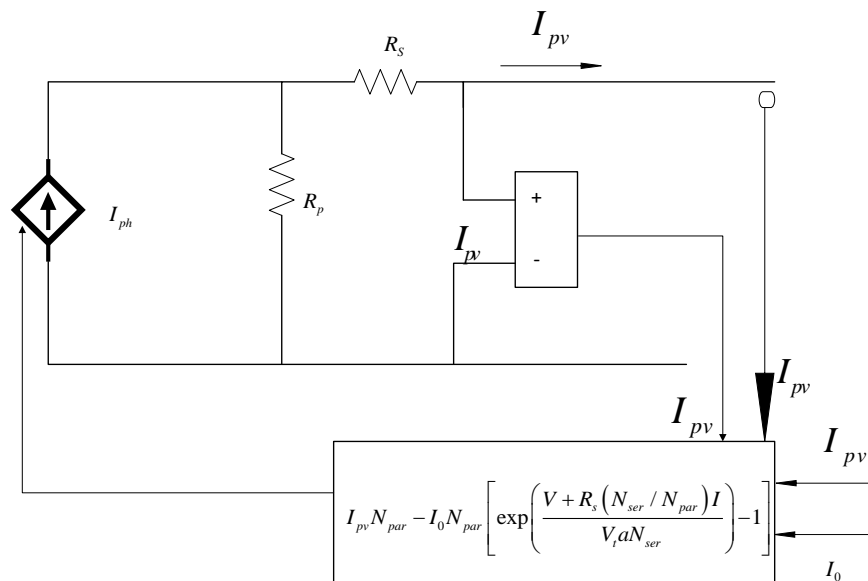

Fig.3.6: Circuit Model Structure of PV Array

$$I = I_{pv}N_{par} - I_0N_{par} \left[\exp\left(\frac{V + R_s \left(\frac{N_{ser}}{N_{par}}\right) I}{V_i a N_{ser}}\right) - 1 \right] - \frac{V + R_s \left(\frac{N_{ser}}{N_{par}}\right) I}{R_p \left(\frac{N_{ser}}{N_{par}}\right)} \quad (3.1)$$

3.4 Designing of Boost Converter

MATLAB Simulink model of Boost Converter is shown in Fig.3.5. The input of the boost converter is the photovoltaic output voltage. The inductance and capacitance need to be specified in the Boost Converter model.

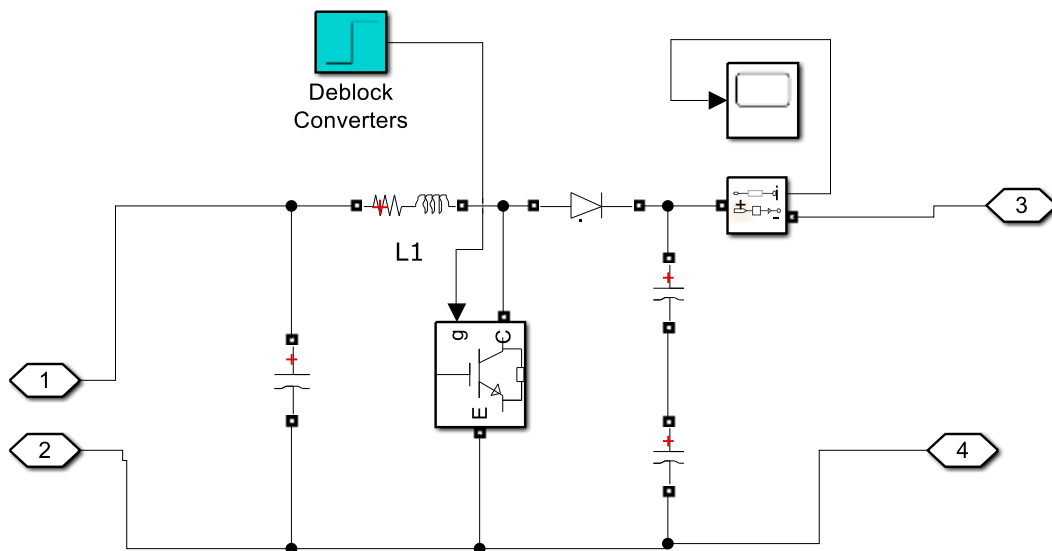

Fig.3.7: MATLAB Model of Boost Converter

3.4.1 Operation of Boost Converter

The conversion of the DC input from the PV into a higher DC output is considered to be the main purpose of the DC/DC converters. The topology of boost converter works on the same principle and hence, used for the stepping up the low voltage input from the PV.

The Fig.3.8 shows the schematic circuit diagram of the boost converter where inductor L is in series with the DC input voltage. The switch T_1 is connected in parallel, which follows ON and OFF routine. Thereby, providing energy from inductor and source to raise the overall average output voltage.

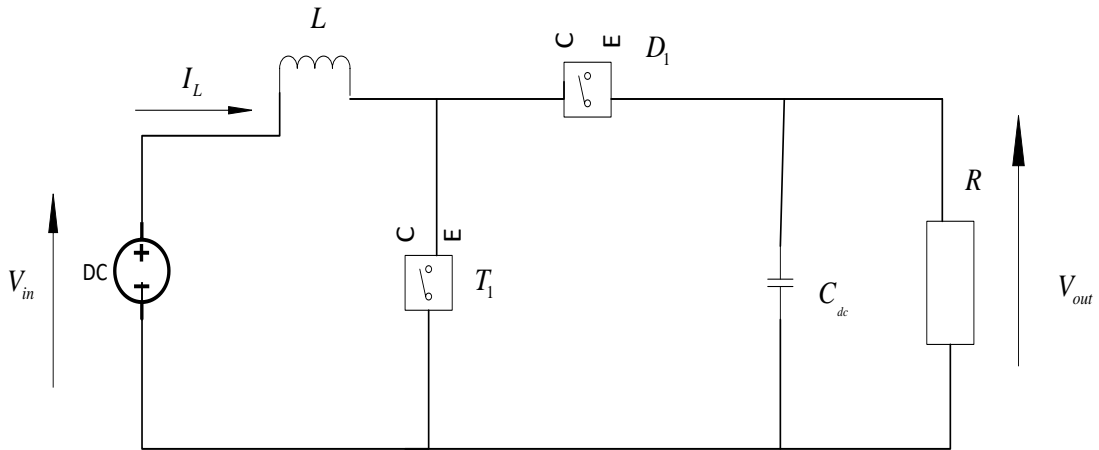

Fig.3.8: Schematic Circuit Diagram of Boost Converter

The voltage ratio of the boost converter is equivalent to the ratio of the switching period to the off time of the used switch as it is derived based on the time integral of the inductor voltage equal to the zero over switching period.

$$\frac{V_0}{V_{in}} = \frac{T_1}{T_{1off}} = \frac{1}{1-D_1} \quad (3.2)$$

In Fig.3.9 T_1 is on and D_1 is off, the circuit is split into two parts. The one with source and inductor and the other has a capacitor. The capacitor sustains the outgoing voltage which was stored once. While in Fig.3.10 the switch T_1 is off and D_1 is on. There is a boost for the output voltage as stored energy from the inductor helps in having supplement power for the circuit. Gradually, inductor discharges and the output voltage can be maintained at a defined level as per the demand.

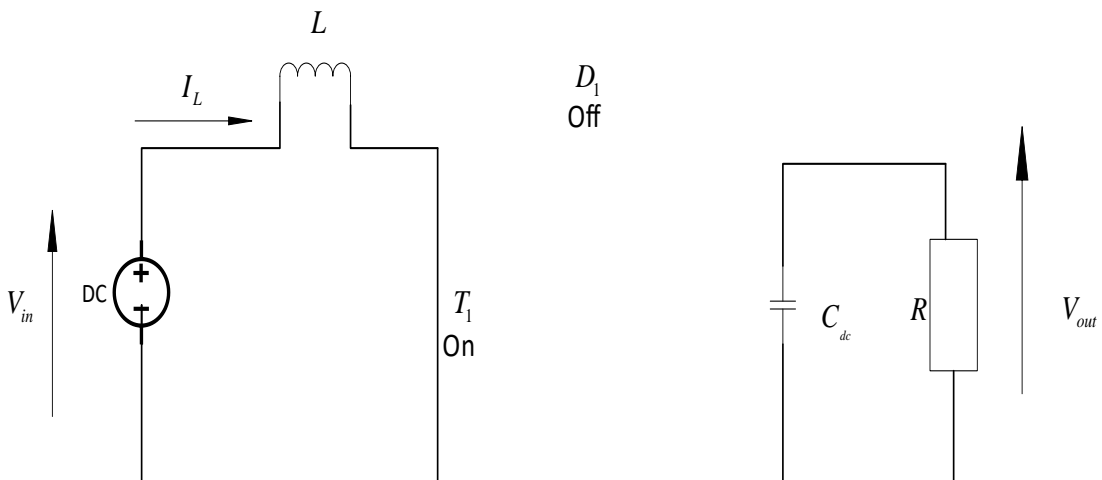

Fig.3.9: Diagram when Switch T_1 is ON

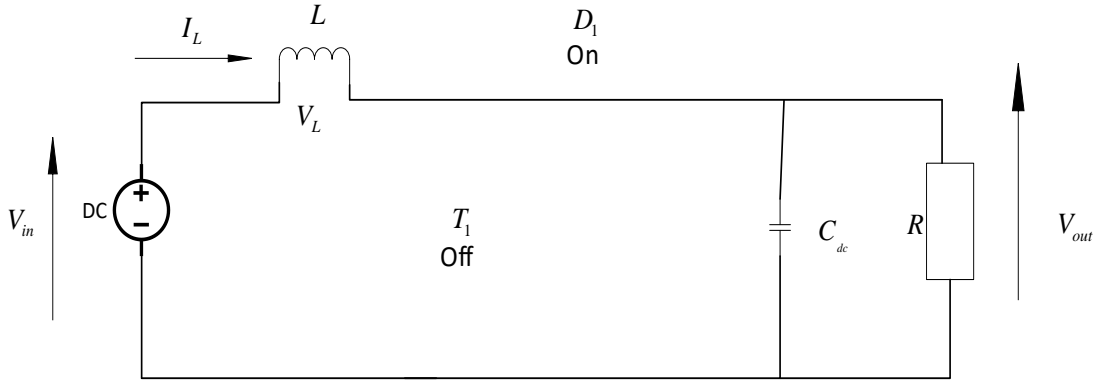

Fig.3.10: Diagram When Switch D_1 is On

When T_1 is ON, the voltage across inductor V_L can be written as:

$$V_L = V_{in}$$

$$I_C = -\frac{V_{out}}{R} \quad (3.3)$$

When T_1 is OFF, V_L is expressed as:

$$V_L = V_{in} - V_{out}$$

$$I_C = I_L - \frac{V_{out}}{R} \quad (3.4)$$

Assuming a small ripple approximation, $I_L \approx I$. In an established condition, the time integral of voltage is zero.

$$\int V_L(t) dt = (V_{in})DT_s + (V_{in} - V_{out})D'T_s \quad (3.5)$$

After equating to zero, the equation of voltage output will be:

$$V_{out} = \frac{V_{in}}{D} = \frac{V_{in}}{1-D} \quad (3.6)$$

3.5 Inverter Configuration

Voltage Source Inverter is developed for getting the output as AC voltage and feeding it to the developed grid. The MATLAB/Simulink Library offers a universal bridge which is used in the present model. The Universal Bridge inverter block as presented in Fig.3.11 allows stimulation of converters using both naturally commutated

(line-commutated) power electronic devices (diodes and thyristor) forced-commutated devices (IGBT, MOSFET). The Pulse Width Modulator, in turn, has an external supply connected to a sinusoidal carrier wave as shown in Fig.3.12. The V-I measurement is further connected to a series transformer and three-phase AC source.

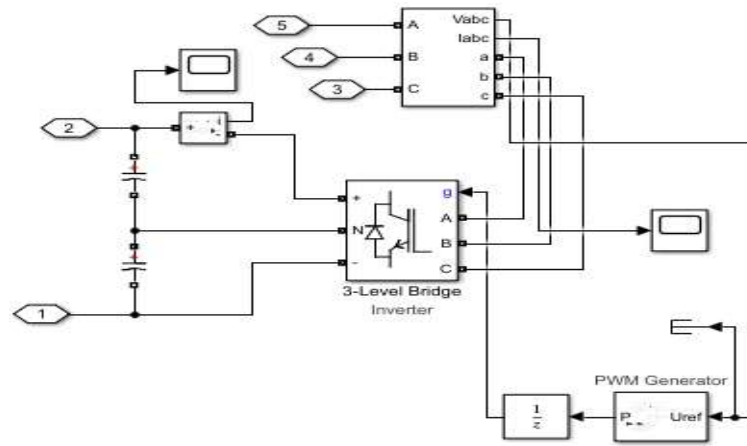

Fig.3.11: MATLAB model of Voltage Source Converter

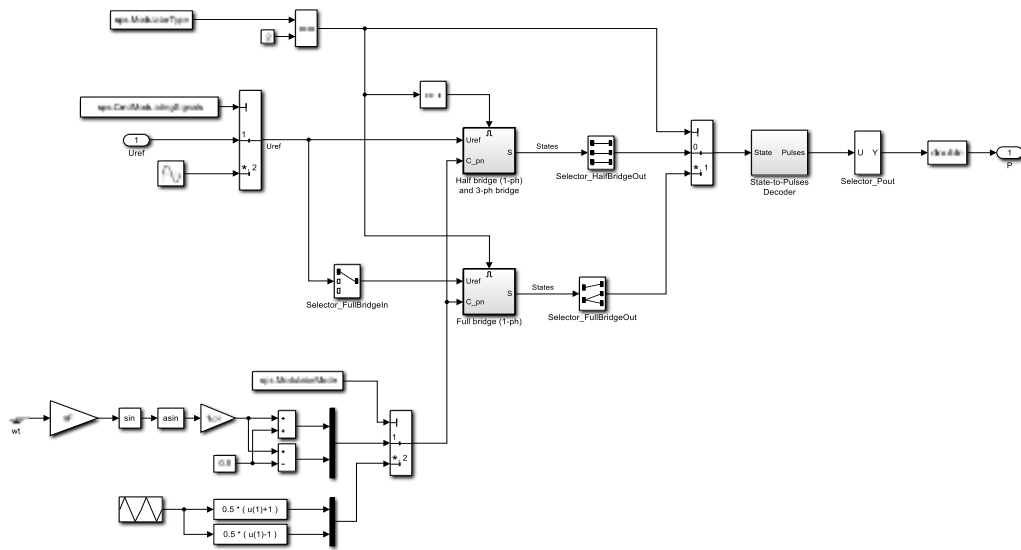

Fig.3.12: Simulink Model of Discrete PWM Generator

3.6 Three-Phase System Confederated Photovoltaic and Unified Power Quality Conditioner (PV-UPQC)

A model of Unified Power Quality Conditioner (UPQC) is developed with three-phase voltage sources with Photovoltaic (PV) Array integrated on its DC-link in MATLAB. The UPQC is based on series active power filter and shunt power filter. The Phase-Locked Loop (PLL) controller is used in the series active power filter and the hysteresis controller is used in shunt active power filter.

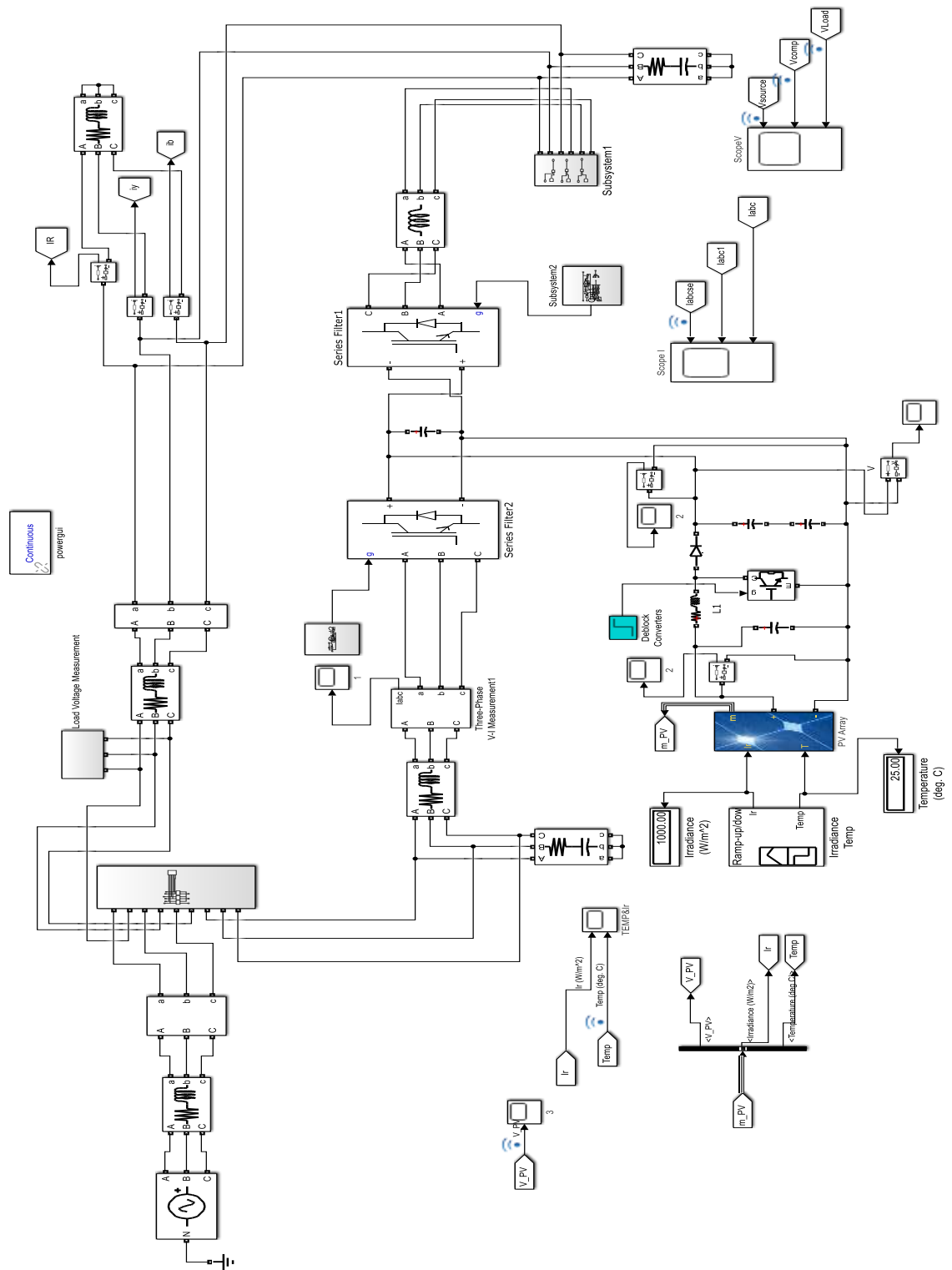

Fig.3.13: Simulink Model Three-Phase Confederated PV-UPQC System

The composed system consists of a PV array with a boost converter, Unified Power Quality Conditioner with series and shunt active filter, grid with the three-phase voltage source. The Three-Phase voltage source is used from where the line is connected to the series transformer followed by the series compensator. The shunt compensator is

connected at other ends before load for purpose of current harmonics mitigation. All these models are separated modelled and then stimulated. The Fig.3.13 MATLAB model of the three-phase system confederated with PV and UPQC. PV Array is directed connected to the DC-link which is present between series active power filter and shunt active power filter and therefore, an inverter is not used in the proposed system.

3.7 Designing of Unified Power Quality Conditioner (UPQC)

The main components of the Unified Power Quality Conditioner are series and shunt compensators where active power filters are used significantly as shown in Fig.3.14. The shunt compensators assist in improving the power quality by removing the current harmonics disturbances. While the series compensator, provide protection by removing voltage interruptions. The Unified Power Quality Conditioner eventually creates an environment of less total harmonic distortion and better efficiency.

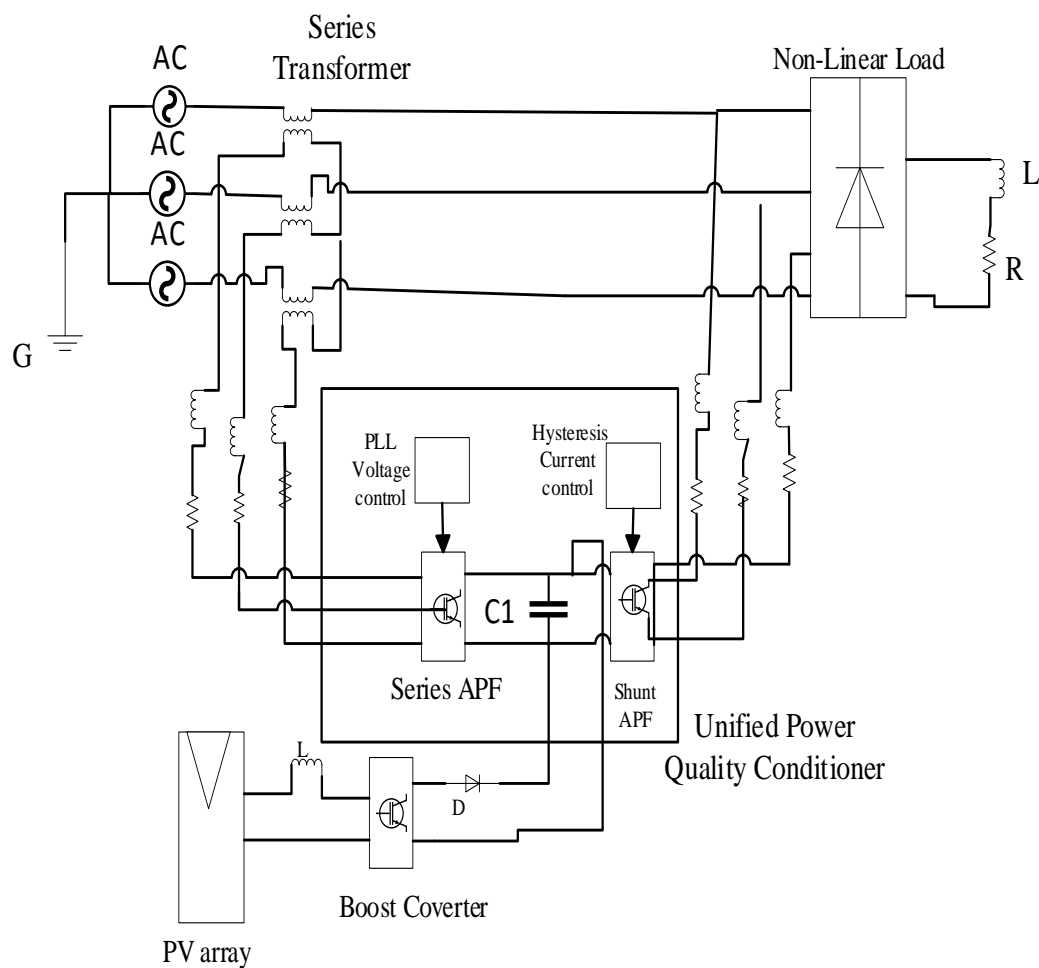

Fig.3.14: Configuration of System containing UPQC

3.8 Proposed Structure for Current Harmonics Compensation

Synchronous Reference Frame (SRF) theory is applied to generate the reference currents required to compensate the harmonics at load current and reactive power compensation in an efficient manner. The compensation effectiveness of an active power filter depends on its ability to have minimum error and the delay time. The reference signal calculated is used to compensate for the distorted load current.

3.8.1 Basic Compensation Principle

The non-linear load injects significant current harmonics to the power system creating non-linear load current. At the point of common coupling, the active power filter feeds current harmonics exactly at the opposite phase. This results in mitigation of harmonics by the compensating current. The role of control algorithms is to produce compensating current and it works appropriately to generate the reference current signal and the generating gate pulse.

3.8.2 Estimation of Reference Current

The instantaneous currents can be written as

$$I_{s(1)} = i_{i(t)} - i_{c(t)} \quad (3.7)$$

The source voltage is given by

$$V_s(t) = V_m \sin \omega t \quad (3.8)$$

If the non-linear current is applied, then the load current can be given as

$$\begin{aligned} I_{l(t)} &= \sum i_n \sin(n\omega t + \phi_n) \\ &= I_{i(x)} \sin(n\omega t + \phi_n) + \sum_{n=2} \dots \sin(n\omega t + \phi_n) \end{aligned} \quad (3.9)$$

The instantaneous load power can be given as

$$\begin{aligned} P_i(t) &= V_s(t) * I_i(t) \\ &= V_m I_1 \sin 2\omega t * \cos \phi_1 + V_m I_1 \sin \omega t * \cos \omega t * \sin \phi_1 + V_m \sin \omega t * \sum I_n \sin(n\omega t + \phi_n) \\ &= P_{f(t)} + P_{r(t)} + P_{h(t)} \end{aligned} \quad (3.10)$$

The fundamental power drawn by the load is

$$P_{f(t)} = V_m I_1 \sin 2\omega t \cos \phi_1 = V_{s(t)} i_{s(t)} \quad (3.11)$$

From the source current supplied by the source, after compensation is

$$I_{s(t)} = P_{f(t)} / V_{s(t)} = I_1 \cos \phi_1 \sin \omega t = I_{sm} \sin \omega t \quad (3.12)$$

Where

$$I_{sm} = I_1 \cos \phi_1 \quad (3.13)$$

There are also some switching losses in the PWM converter, and hence the utility must supply a small overload for the capacitor leakage and converter switching losses in addition to the real power.

The total peak current supplied by the source is therefore given by

$$I_{sp} = I_{sm} + I_{s1} \quad (3.14)$$

The (t) will be in phase with the utility voltage present and will be purely sinusoidal if the active filter presents the total reactive and harmonic power. The compensating current provided by the active filter at this time is as follows:

$$I_{c(t)} = I_{l(t)} + I_{s(t)} \quad (3.15)$$

Hence, for accurate and instantaneous compensation of reactive power and harmonics, it is essential to estimate the fundamental component of the load current as of the reference current.

3.8.3 Estimation of Source Current

The peak value of the reference current I_{sp} can be estimated by controlling the DC side voltage. The desired source currents, after compensation, can be given as

$$I_{sa}^*(t) = I_{sp} \sin \omega t \quad (3.16)$$

$$I_{sb}^*(t) = I_{sp} \sin(\omega t - 120^\circ) \quad (3.17)$$

$$I_{sc}^*(t) = I_{sp} \sin(\omega t + 120^\circ) \quad (3.18)$$

where

$$I_{sp} = I_1 \cos \phi + I_{s1} \quad (3.19)$$

The SRF theory is used for the reference current generation and the reference currents can be estimated by multiplying this maximum value (peak value) with unit sine vectors present in phase with the source voltages.

3.8.4 Design of DC Side Capacitor

The instantaneous power flow is the concept which helps in deciding the DC side capacitor. The selection of C_{dc} can be done by decreasing the voltage ripple. As per the given specification of the peak to peak voltage ripple ($V_{dcp-p(max)}$) and rated filter current ($I_{Cl_{rated}}$), the DC side capacitor can be expressed by the following equation.

$$C_{dc} = (\Pi * I_{Cl_{rated}}) / \sqrt{3} W V_{dcp-p(max)} \quad (3.20)$$

3.9 Control Strategies for Shunt Active Power Filter

To initiate appropriate gating signals for the switching purposes is the main objective of the used control strategy. The control system has synchronous reference frame theorem-based compensation and hysteresis current controller for gate signal generation.

3.9.1 SRF Theory Based Current Control Strategy

The synchronous reference frame theory or d-q theory is based on the concept of time-domain reference signal estimation techniques. It supports the active power filter system in the steady-state and the transient state as well as in real-time scenarios. Another magnificent attractive quality of this controller is the simplified calculations.

The reference frame transformation is formulated from a three-phase a-b-c stationary system to the direct axis(d) and the quadratic axis(q) rotating coordinate system. The basic structure involves direct (d-q) and inverse (d-q)-1 park transformation as shown in Fig.3.15.

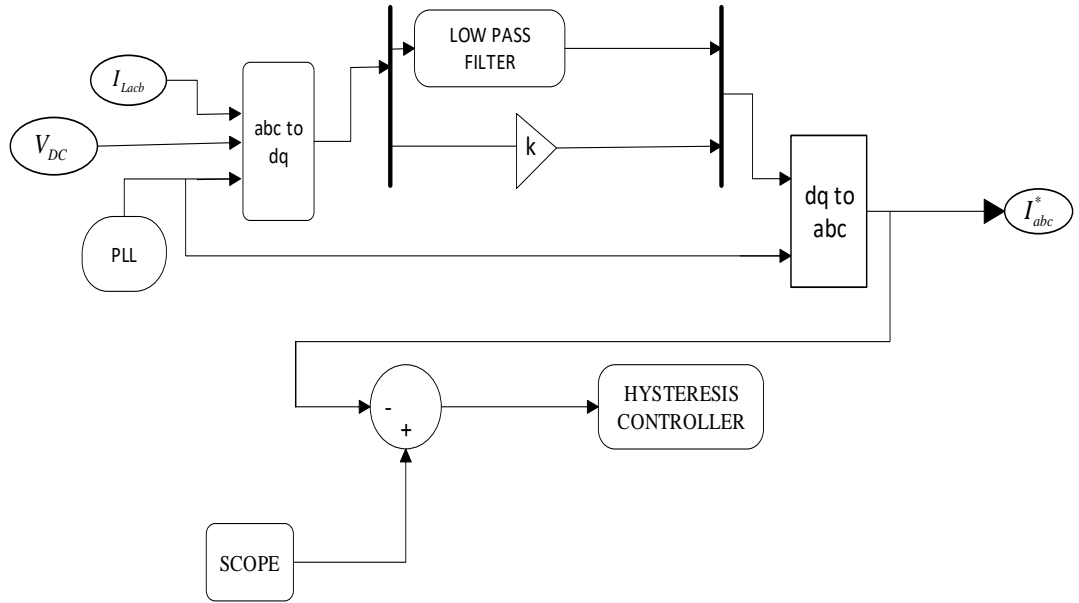

Fig.3.15: Synchronous d-q-0 Reference Frame-based Compensation Algorithm

The reference frame theory-based d-q model for shunt active power filter is presented. The Instantaneous voltages and currents in the RYB coordinates are transformed into two-axis coordinates represented by α and β .

$$V = [V_R \quad V_Y \quad V_B]^T \quad (3.21)$$

$$I = [i_R \quad i_Y \quad i_B]^T \quad (3.22)$$

By Clarke Transformation,

$$\begin{bmatrix} V_\alpha \\ V_\beta \\ V_0 \end{bmatrix} = T_1 \begin{bmatrix} V_R \\ V_Y \\ V_b \end{bmatrix} \quad (3.23)$$

$$\begin{bmatrix} i_\alpha \\ i_\beta \\ i_0 \end{bmatrix} = T_1 \begin{bmatrix} i_R \\ i_Y \\ i_B \end{bmatrix} \quad (3.24)$$

$$T_1 = \sqrt{\frac{2}{3}} \begin{bmatrix} 1 & -\frac{1}{2} & -\frac{1}{2} \\ 0 & \frac{\sqrt{3}}{2} & -\frac{\sqrt{3}}{2} \\ \frac{1}{\sqrt{2}} & \frac{1}{\sqrt{2}} & \frac{1}{\sqrt{2}} \end{bmatrix} \quad (3.25)$$

$$\begin{bmatrix} V_\alpha \\ V_\beta \end{bmatrix} = \sqrt{\frac{2}{3}} \begin{bmatrix} 1 & -\frac{1}{2} & -\frac{1}{2} \\ 0 & -\frac{\sqrt{3}}{2} & \frac{\sqrt{3}}{2} \end{bmatrix} \begin{bmatrix} V_R \\ V_B \\ V_Y \end{bmatrix} \quad (3.26)$$

$$\begin{bmatrix} V_d \\ V_q \end{bmatrix} = T_2 \begin{bmatrix} V_\alpha \\ V_\beta \end{bmatrix} \quad (3.27)$$

$$T_2 = \begin{bmatrix} \cos \omega_r & -\sin \omega_r \\ \sin \omega_r & \cos \omega_r \end{bmatrix} \quad (3.28)$$

The voltage and current in α and β reference frame can be expressed as shown in the equation. The voltage reference frame can be further transformed in a rotating reference frame with ω_r an angular velocity in the d-q frame. Unit vector generation for this transformation is done by step down grid voltage.

$$\begin{bmatrix} V_a \\ V_b \\ V_c \end{bmatrix} = \begin{bmatrix} \sin \omega t & \cos \omega t & 1 \\ \sin\left(\omega t - \frac{2\Pi}{3}\right) & \cos\left(\omega t - \frac{2\Pi}{3}\right) & 1 \\ \sin\left(\omega t + \frac{2\Pi}{3}\right) & \cos\left(\omega t - \frac{2\Pi}{3}\right) & 1 \end{bmatrix} \times \begin{bmatrix} V_d \\ V_q \\ V_0 \end{bmatrix} \quad (3.29)$$

$$\begin{bmatrix} I_a \\ I_b \\ I_c \end{bmatrix} = \begin{bmatrix} \sin \omega t & \sin\left(\omega t - \frac{2\Pi}{3}\right) & \sin\left(\omega t - \frac{2\Pi}{3}\right) \\ \cos(\omega t) & \cos\left(\omega t - \frac{2\Pi}{3}\right) & 1 \\ \frac{1}{2} & \frac{1}{2} & \frac{1}{2} \end{bmatrix} \times \begin{bmatrix} I_a \\ I_b \\ I_c \end{bmatrix} \quad (3.30)$$

The d-q transformation output signals depend on the load current (fundamental and harmonic components) and the performance of the Phase Locked Loop (PLL). The

rotational speed(rad/sec) is provided by the PLL circuit and ωt is set as a fundamental frequency component.

The PLL circuit provides the vectorized at 50 Hz frequency followed by $\sin\theta$ and $\cos\theta$ for synchronization. The low pass filter filters the harmonics and it is a second order Butterworth filter, whose cut off frequency is selected to be 25Hz for eliminating higher order harmonics.

3.9.2 Hysteresis Current Control Method

The hysteresis current control is a method of generating the required triggering pulses which are used to control the voltage source inverter. The output current is then generated from the filter which follows the path as traced by reference current waveform. The generated triggering pulses are compared with the error signal of the hysteresis band.

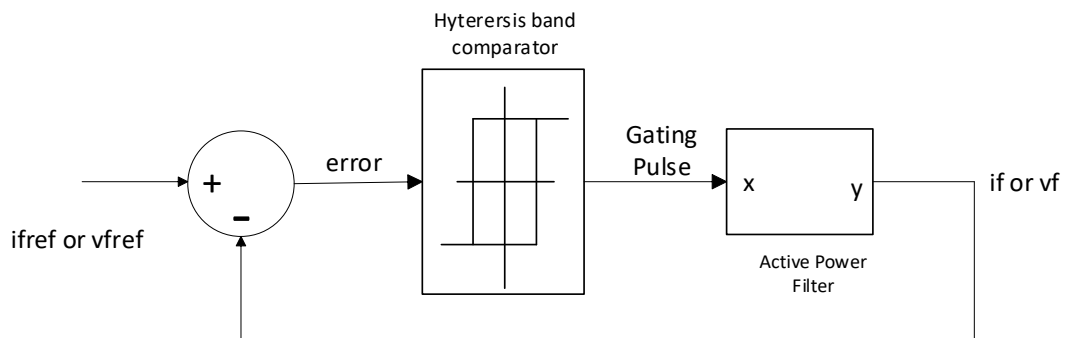

Fig.3.16: Hysteresis Control

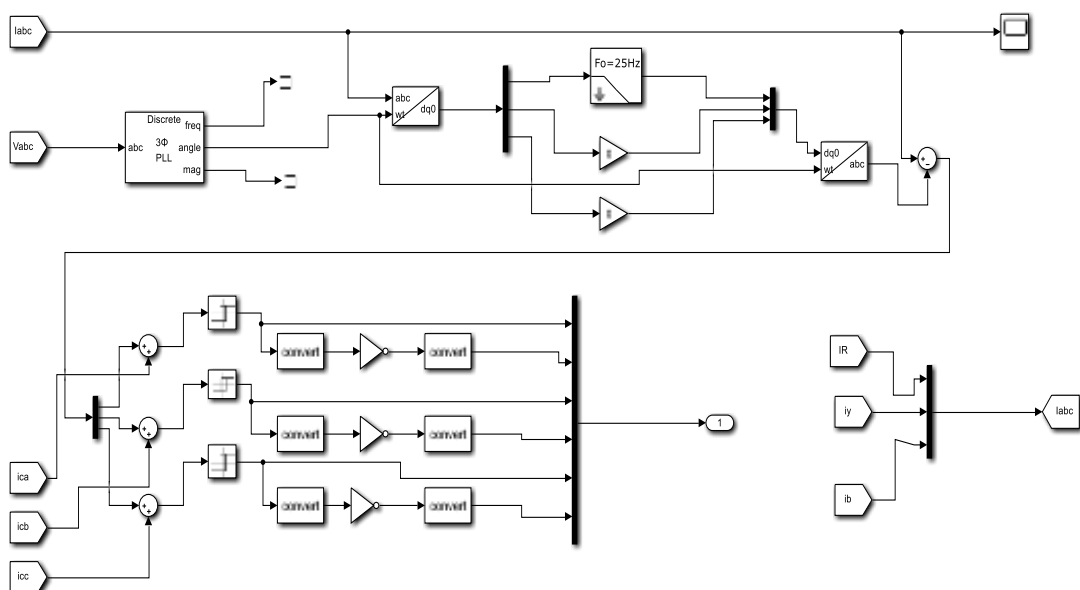

Fig. 3.17: Simulink-Configuration of SRF Technique in Hysteresis Controller

The hysteresis current control is the most convenient control method to implement in real time. The Fig.3.16 illustrates the ramping of the current between the two limits where the upper hysteresis limit is the sum of the reference current and the maximum error or the difference between the upper limit and the reference current. For the lower hysteresis limit is can be determined by the subtraction of the reference current and the minimum error and Simulink-Configuration of SRF technique in Hysteresis Controller is shown in Fig.3.17.

3.10 Control Scheme Series Active Power Filter

The Series Active Filter compensates voltage harmonics and interruptions in the source voltage. The series transformer is used in the system. The control strategies used in the presented model is the synchronous reference frame with the Phase Locked Loop (PLL) controller. The control scheme of a series active filter is purely based on a-b-c to d-q transformation method. The reference voltage with the actual voltage is converted to dq0 from a-b-c coordinates and both are simultaneously compared in the provided dq0 reference frame. After the required comparison conversion is done to fit in the a-b-c reference frame. The Phased Locked Loop (PLL) generates the θ which is used effectively in the Park's transformation and inverse Park's transformation. The switching pulses are generated. The PLL controller thus compares the selected output voltage (V_C^*) with the sensed series APF output voltage (V_C).

The ideal output waveform is generated by the proposed technique as the output is generated by PWM (Pulse Width Modulator) with minimum harmonic distortion and maximum fundamental useful voltage. The Simulink-Configuration of PLL Controller is shown in Fig.3.18 which also consists of the 2-Level PWM generator. The PWM reduces the switching losses and Total Harmonic Distortion (THD).

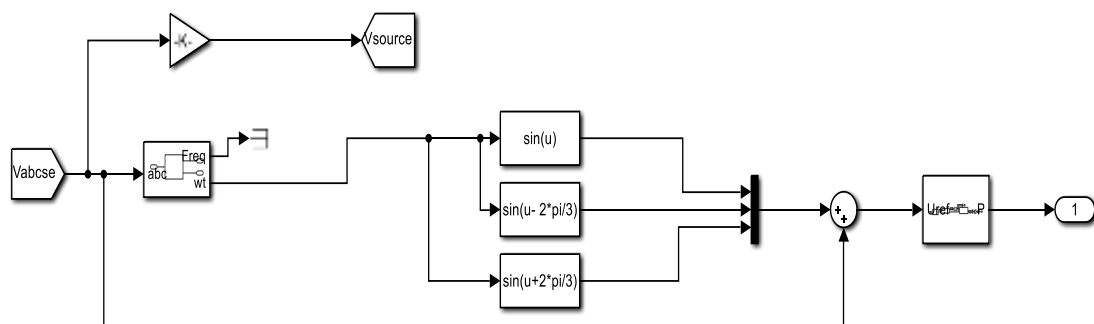

Fig. 3.18: Simulink-Configuration PLL Controller used in Series Active Power Filter

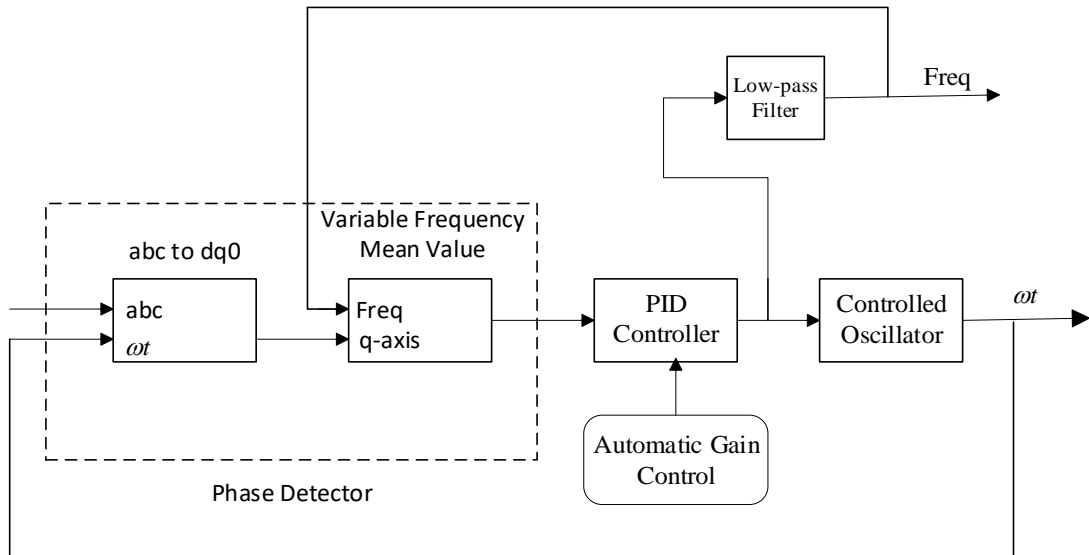

Fig.3.19: Internal Diagram of PLL Controller

A low pass filter is generally used to filter ripple voltage of the DC capacitor, which introduces a finite delay. A continuously changing reference current makes the compensation non-instantaneous during the transient. This voltage is sampled at zero-crossing of the phase voltage which makes the compensation instantaneous during a transient.

A Proportional-Integral-Derivative (PID) controller used in Fig.3.19 is in combination with optional automatic gain control (AGC), which helps in maintaining the phase difference to 0 which follow up on a controlled oscillator. The PID output is utilized as the mean value which is the converted frequency (hertz) from the angular velocity.

3.11 Closure

The mathematical modelling of PV array and boost converter is designed and studied in this chapter. The described Unified Power Quality Conditioner is given by combined functioning of Shunt Active Power Filter and Series Active Power Filter with Synchronous Reference Frame theory. The control strategies of active filters have been discussed in this section. The PLL Controller is used effectively for the removal of voltage interruptions in Series Active Filter while the Hysteresis Controller is used in Shunt Active Power Filter for the elimination of current harmonics.

CHAPTER – 4

RESULTS AND DISCUSSION

4.1 Introduction

This chapter includes the results of the thesis work as the objectives have been achieved by reducing the harmonic elements that exist in the solar PV system with the help of confederated Unified Power Quality Conditioner (UPQC). It covers the evaluation of the mitigation of harmonics with use of three-phase PV-UPQC integrated model. The results are systematically demonstrated by appreciation decrement in the percentage of Total Harmonic Distortion (THD). The performance of the system is evaluated with and without UPQC with the use of FET Analysis in MATLAB.

4.2 I-V and P-V characteristics of PV array of Proposed System

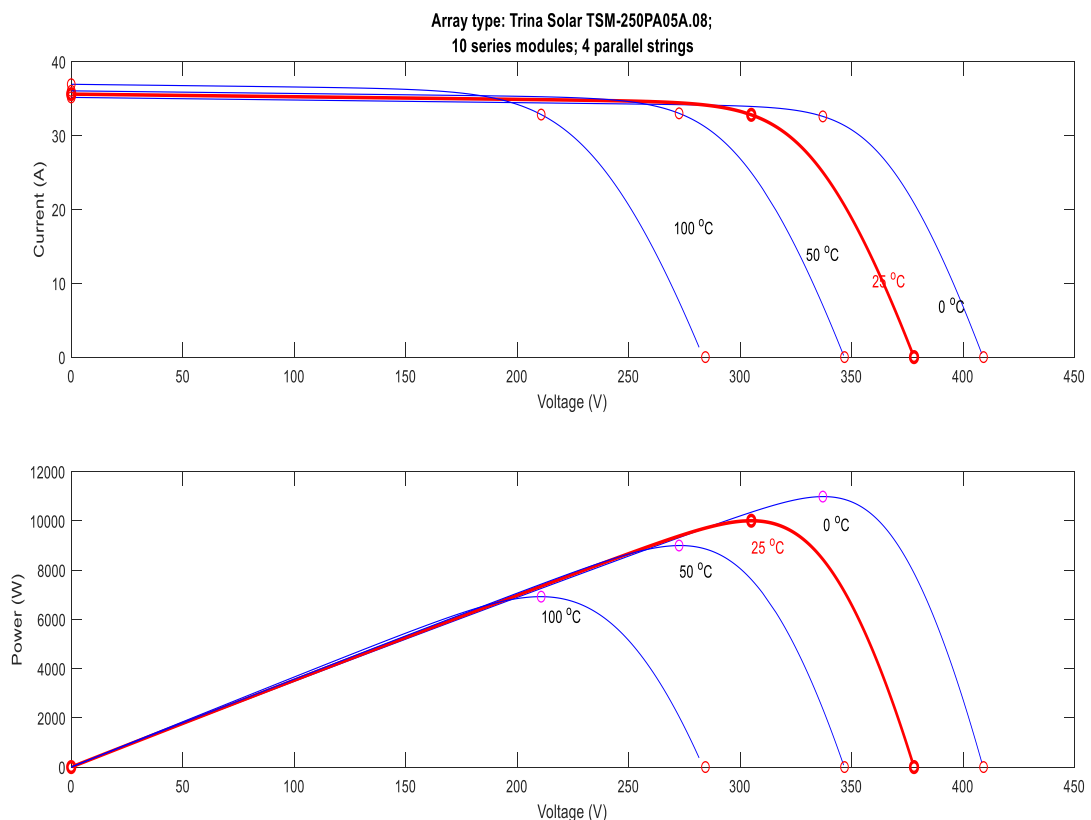

Fig.4.1: I-V Characteristics of PV as Function of Temperature and P-V Curve

The I-V curve of PV array is non-linear and its parameter depends on temperature and irradiance. The change in current with varying temperature is illustrated in Fig.4.1 and

this figure current is observed below than voltage. The second section of the same curve denotes P-V curve of the PV array.

4.3 Waveforms of the System without UPQC

The Fig.4.2 represents the output current of PV Array, the PV voltage first starts to rise at peak and then the sudden dip occurs. In Fig.4.3 boost converter current can be seen with its magnitude fluctuating while the Fig.4.4 demonstrates the waveforms of Boost Converter output voltage.

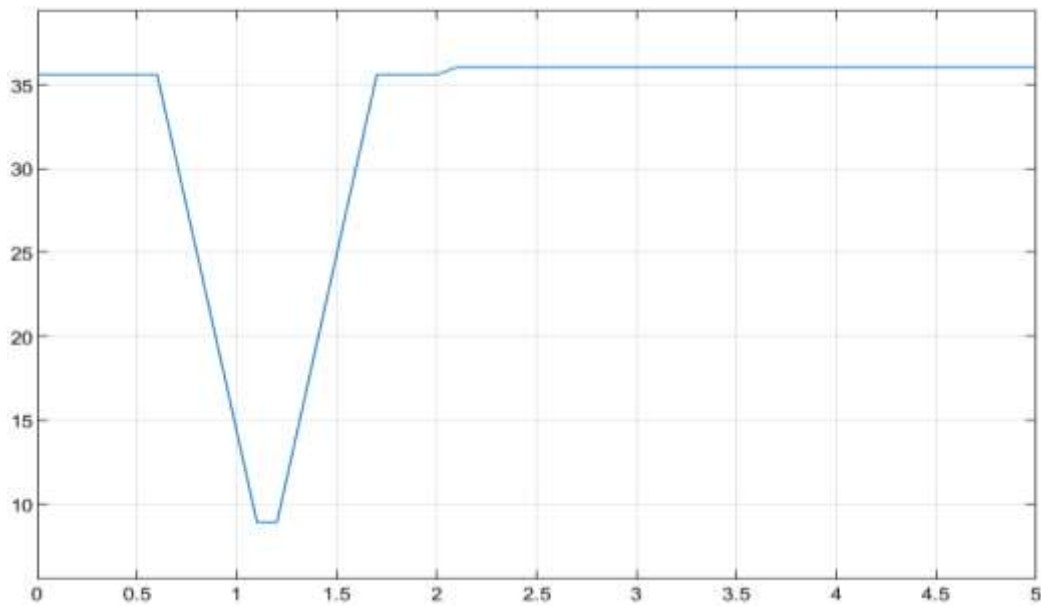

Fig.4.2: Output Current of PV Array without UPQC

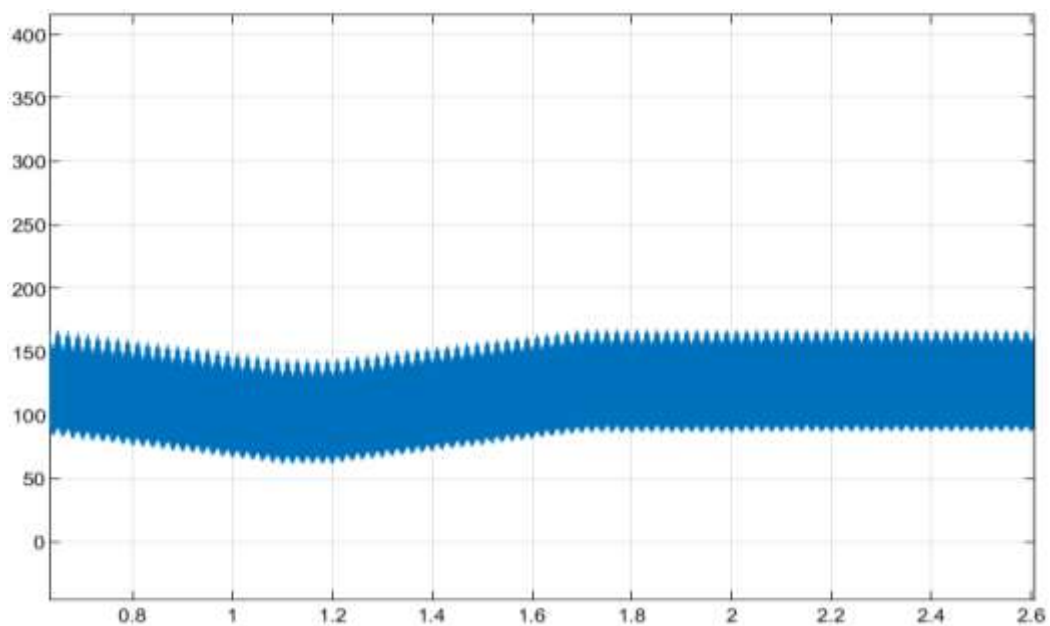

Fig.4.3: Boost Converter Current without UPQC

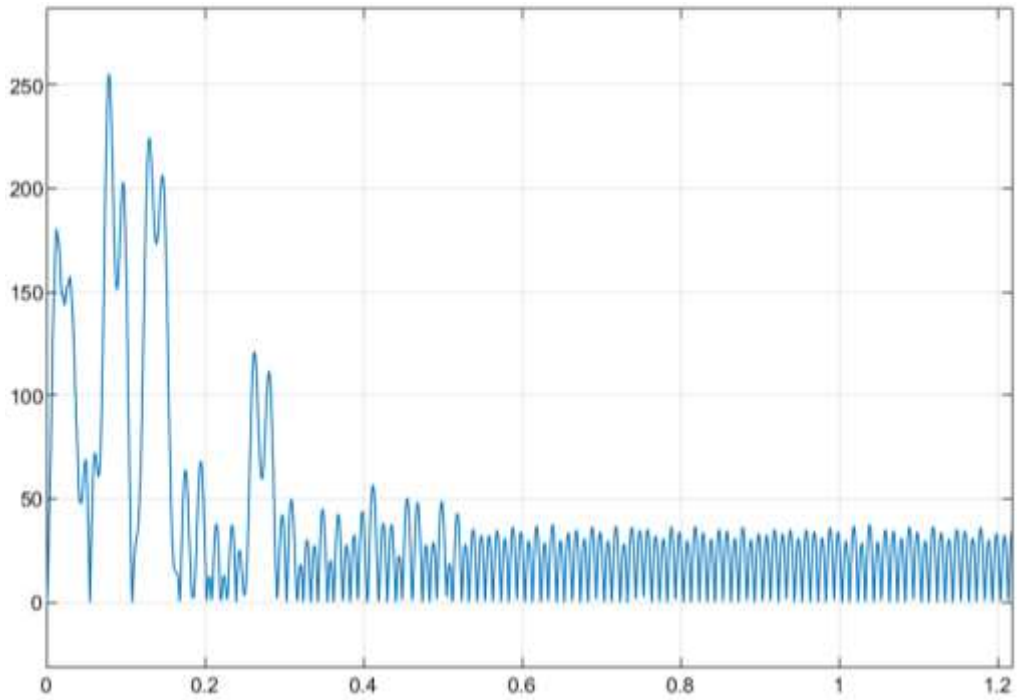

Fig.4.4: Boost Converter Voltage without UPQC

In Fig. 4.5 and Fig 4.6 the output voltage and output current of the inverter are shown. It takes the system 0 to 0.5 seconds to reach the steady-state conditions and harmonics in current and voltage waveforms are present.

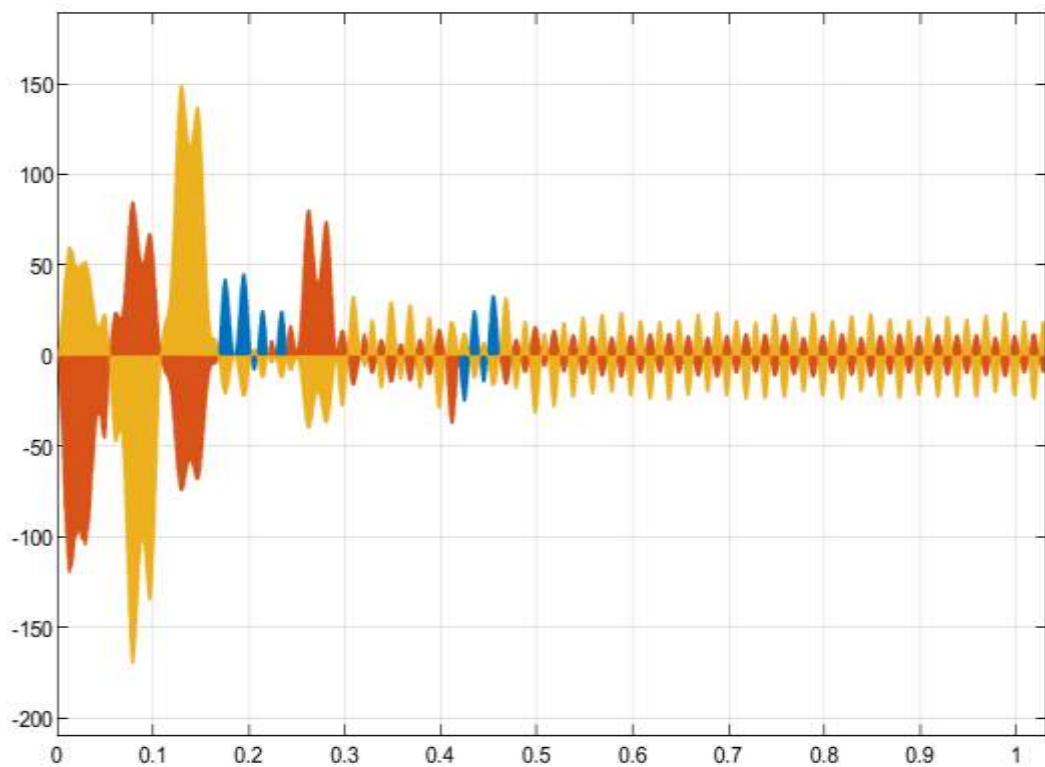

Fig.4.5: Output Voltage of Inverter

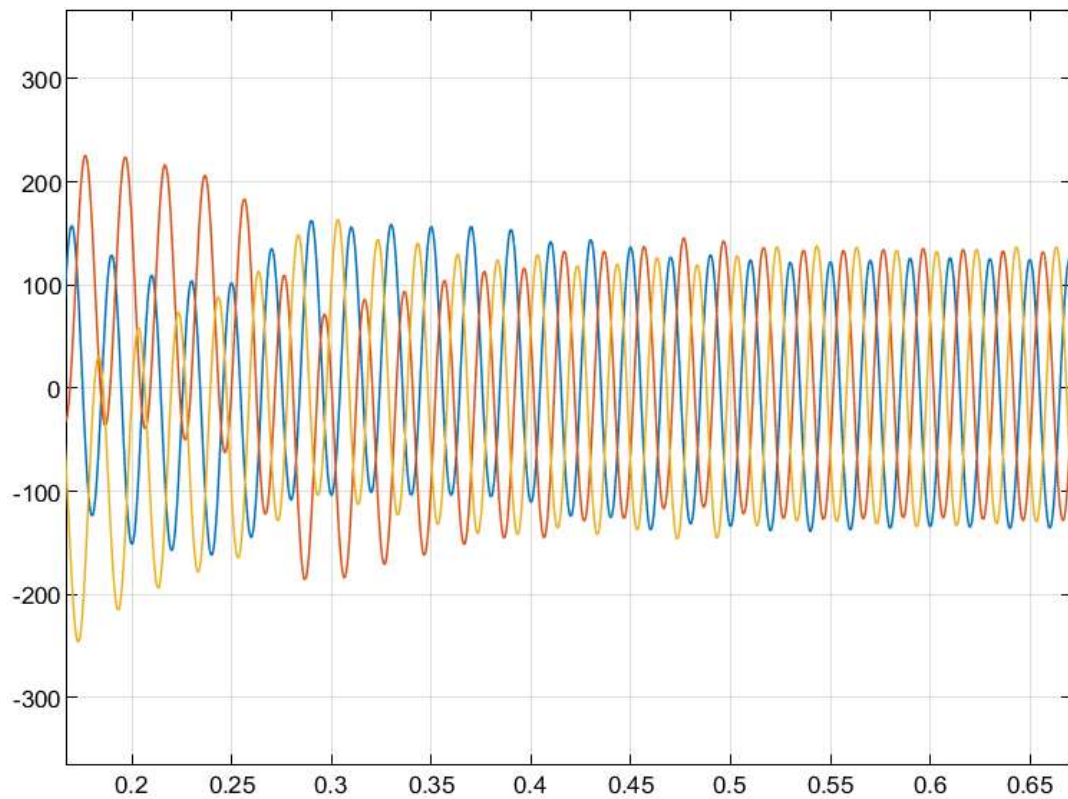

Fig. 4.6: Inverter Current

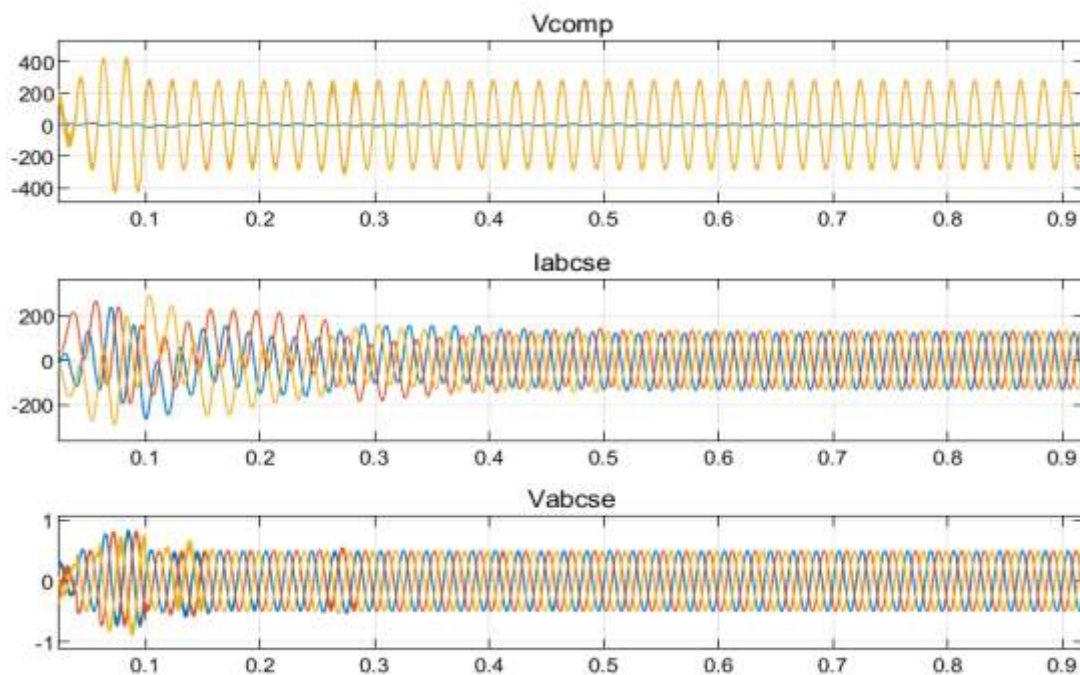

Fig.4.7: (a) Series Transformer Voltage (b) Waveforms of the Source Current and (c) Waveforms of the Source Voltage.

In 4.8 and 4.9 illustrates the FET analysis of source current and load current. The non-linear load is connected to the grid side. Due to these non-linear loads harmonics are

injected into the system which can be observed in FET analysis. In Fig. 4.8 the THD of the source current is 28.96 % and the THD of the voltage source in Fig. 4.9 is 17.48%.

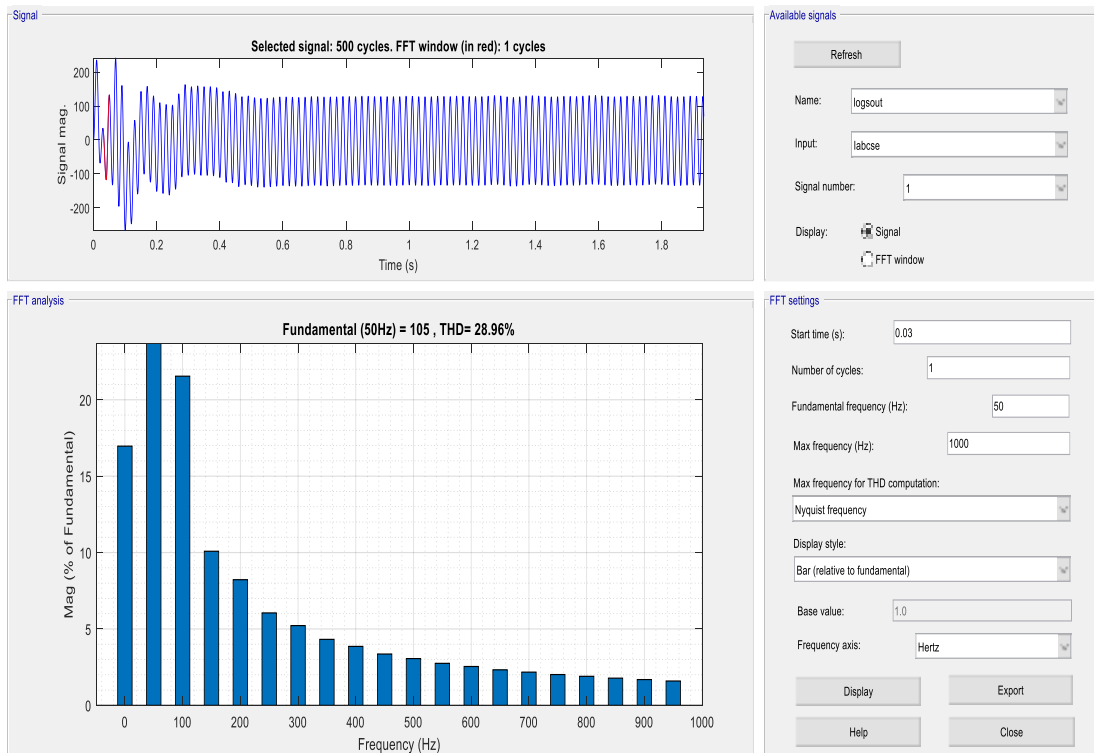

Fig. 4.8: FET Analysis of Source Current without UPQC

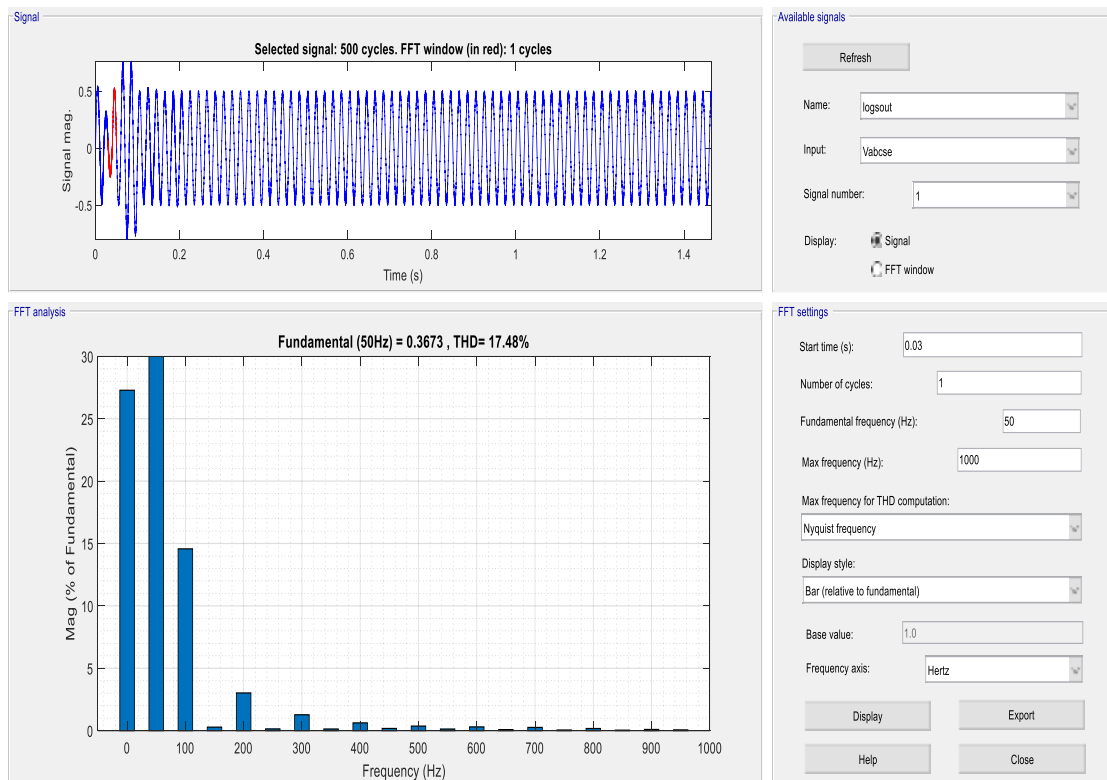

Fig. 4.9: FET Analysis of Source Voltage without UPQC

4.4 Performance of PV in the presence of Installed UPQC

Stimulation results of PV and boost converter after implementing UPQC are shown in Fig.4.10, Fig.4.11 and Fig. 4.12.

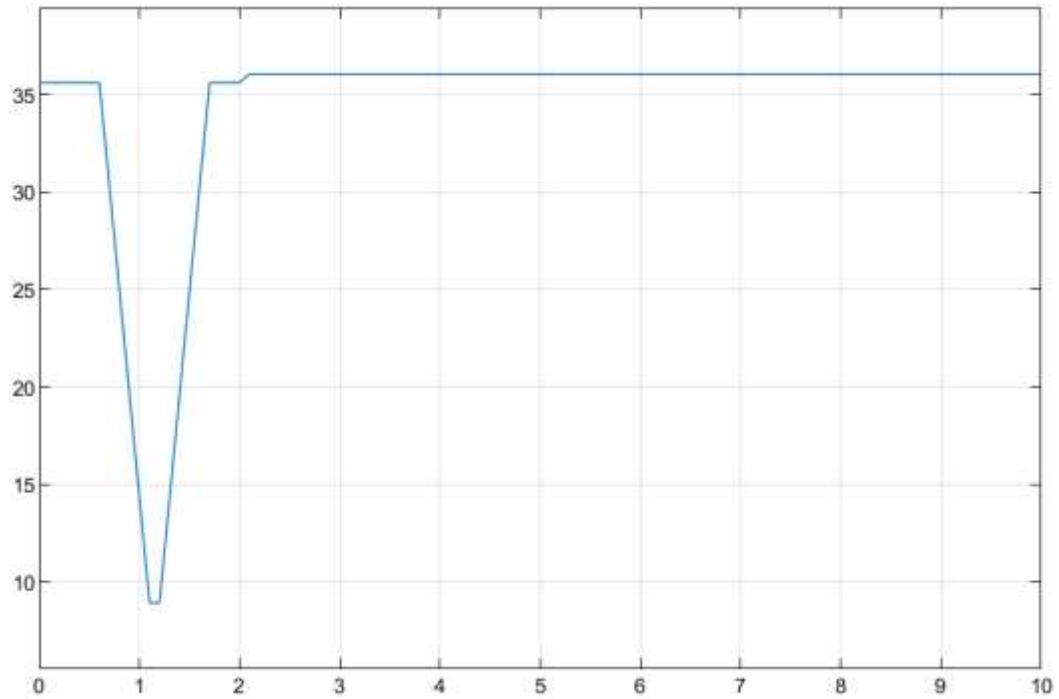

Fig. 4.10: Output Current of PV Array with UPQC

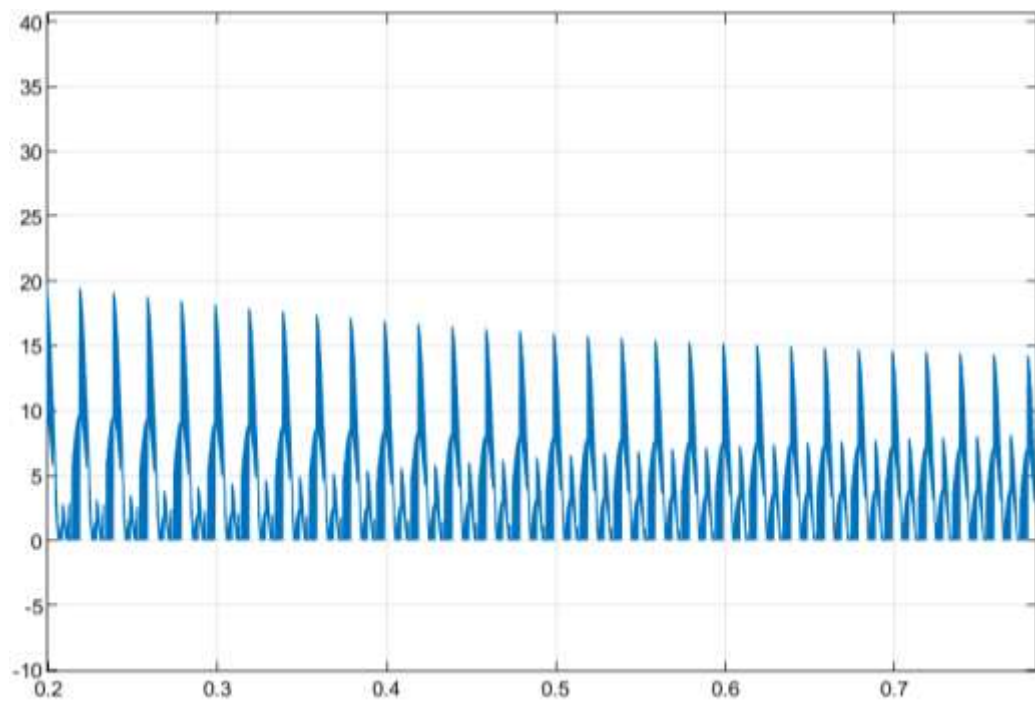

Fig.4.11: Boost Converter Current with UPQC

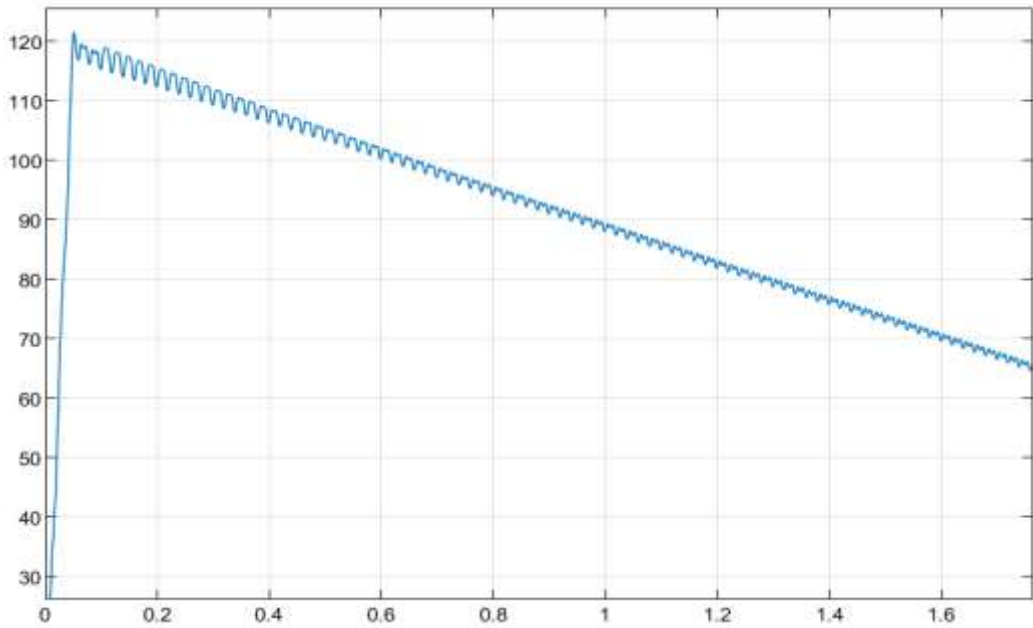

Fig.4.12: Boost Converter Voltage with UPQC

4.5 Performance of PV-UPQC Confederated System under Various Dynamic Conditions

4.5.1 Case I - Performance under Varying Irradiation

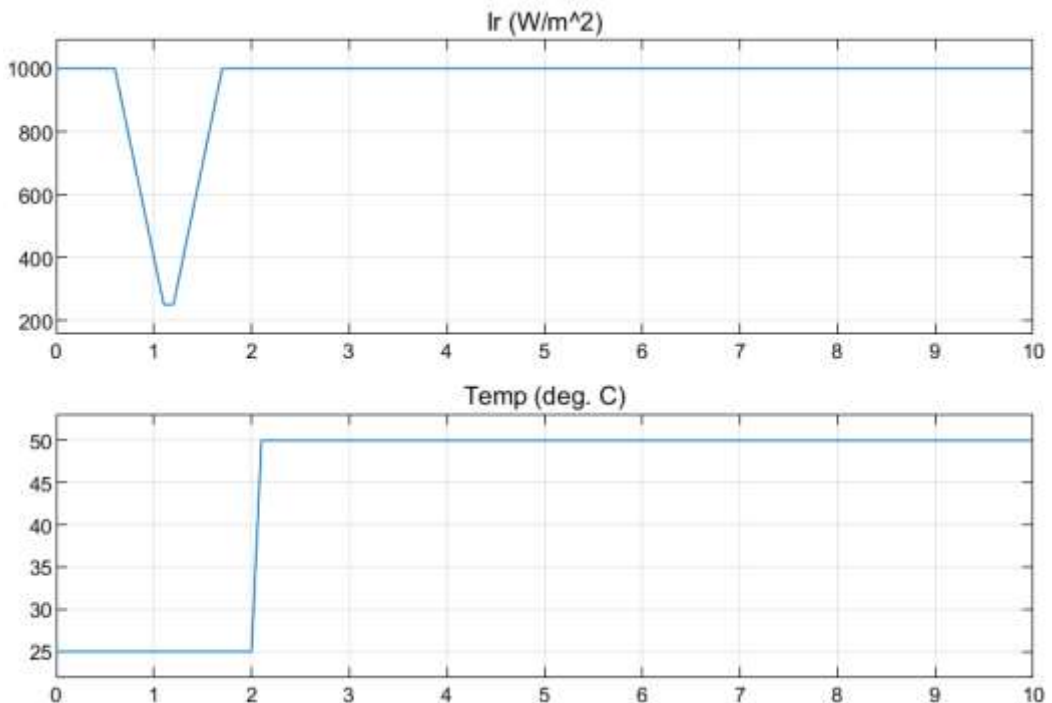

Fig.4.13: (a) Irradiance Variation (b) Temperature Variation

The Fig.4.13 shows the varying irradiation and temperature in dynamic conditions of the model and the system performance is observed.

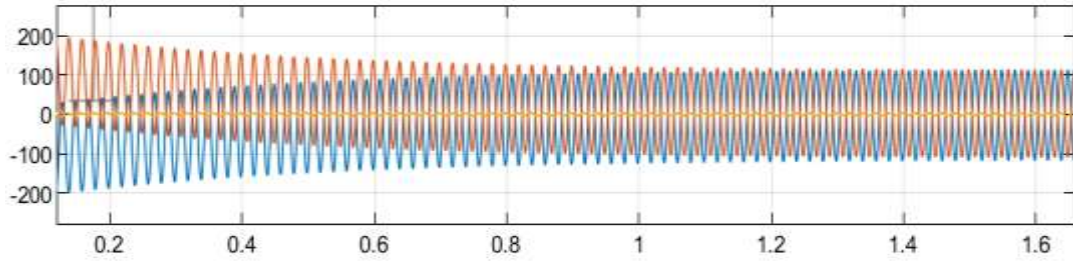

Fig.4.14: Source Current under Varying Irradiance

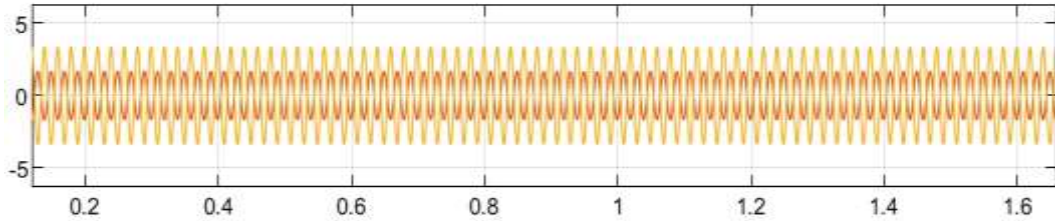

Fig.4.15: Load Current under varying Irradiance

The evaluated performance of the PV-UPQC dynamic model respect to time (X-axis) under varying irradiance between 250 W/m^2 and 1000 W/m^2 is stable as observed in Fig.4.14 and Fig.4.15. The output current of the load is observed with fewer harmonics.

4.5.2 Case II–Performance of Confederated PV-UPQC system under Current Unbalance Conditions

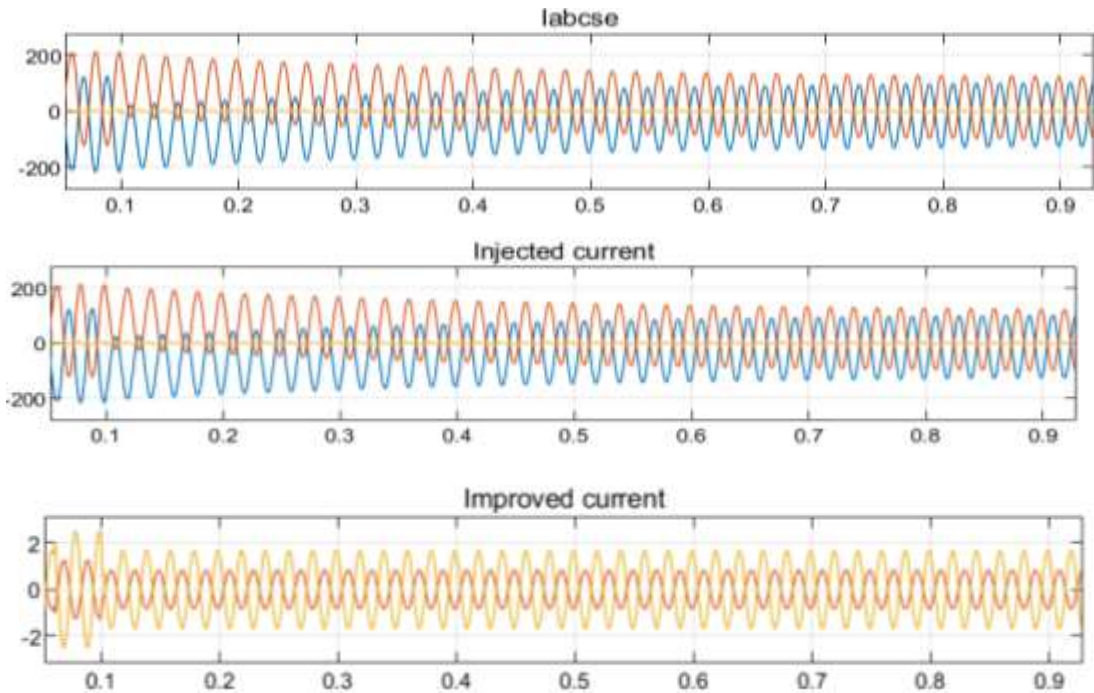

Fig.4.16: (a) Source Current under Unbalance Current Conditions (b) Injected Current from Shunt Compensator (c) Improved Current after Compensation

The current after compensation is shown in Fig.4.16(c) and source current under unbalance current conditions is demonstrated in Fig.4.16(a). The performance of a shunt active filter has been evaluated under current unbalance conditions in Fig.4.16. The waveform from the hysteresis controller of synchronous reference frame compensates the harmonic current as they are introduced to the non-linear load in opposite phase and this results in a cancelling effect of harmonics by shunt active power filter. Harmonics are eliminated, power quality is improved and amplitude of the generated current by the non-linear load is in the range of active filter parameter.

4.5.3 Case III - Performance of PV-UPQC under Voltage Fluctuation

The voltage after compensation is demonstrated in Fig.4.17(c). The Irradiance is maintained at 1000 W/m^2 . The performance of a series active filter has been evaluated in Fig.4.17 where voltage interruptions have been removed successfully.

The series compensator eliminates voltage sag and voltage swell by injected favourable voltage in opposite phase with the grid voltage disturbance and thereby, balancing the fluctuating voltage in the system under dynamic conditions. The system is observed to be stable under dynamic conditions of voltage fluctuations.

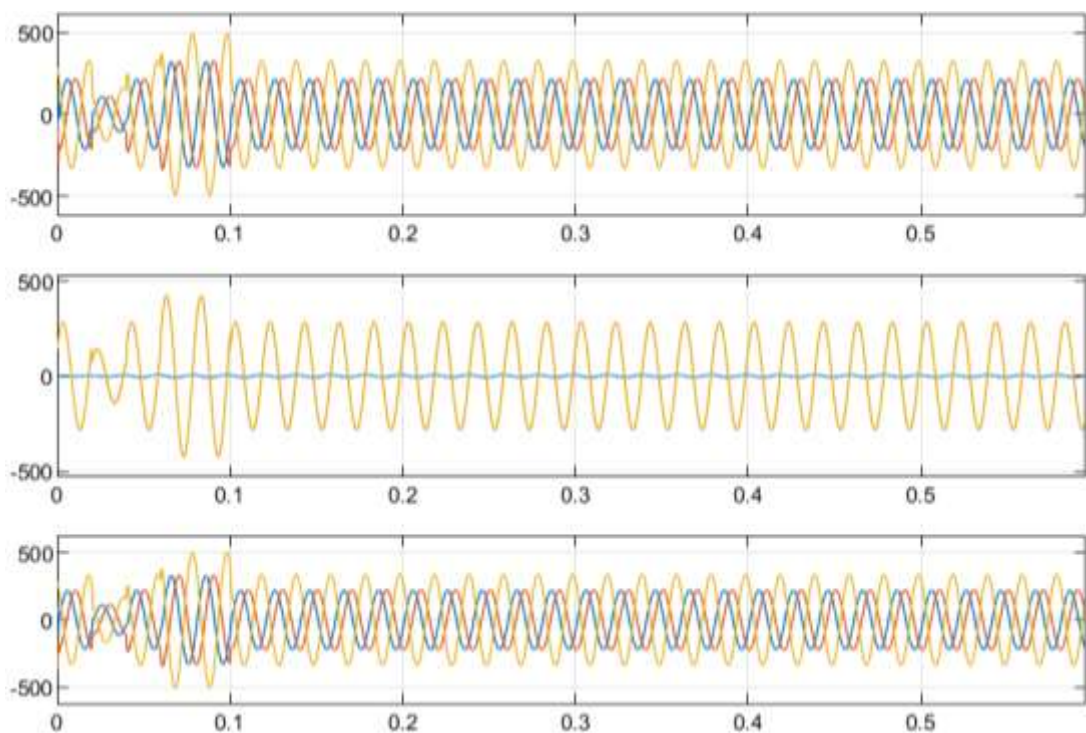

Fig.4.17: (a) Three-phase Input Voltage (b) Compensating Voltage (c) Load Voltage

4.5.4 Case IV - At Negligible Temperature and Irradiance at 1°C and 1 W/m²

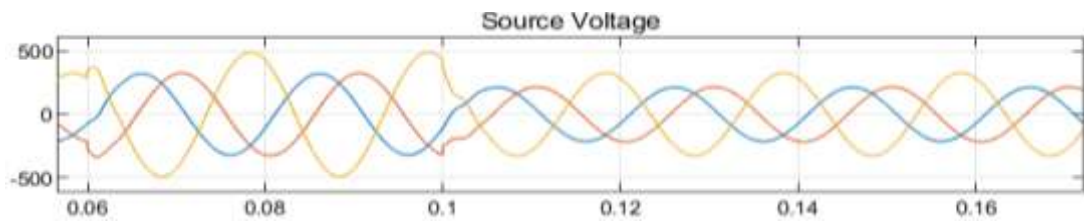

Fig.4.18: Voltage Source at Temperature and Irradiance at 1°C and 1 W/m²

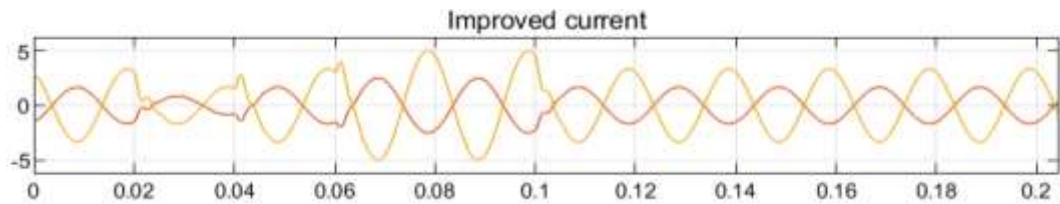

Fig.4.19: Load Current at Temperature and Irradiance at 1°C and 1 W/m²

The current generated at the load is negligible and sinusoidal waveforms can be observed after 0.12 seconds but the system is stable and reliable in this state of negligible Temperature and Irradiance. The Fig.4.18 illustrates the Source Voltage at Temperature and Irradiance at 1°C and 1 W/m² while Fig.4.19 shows Source Voltage at Temperature and Irradiance at 1°C and 1 W/m².

4.5.5 Case V-Load is Zero and Generated Power is Continuous

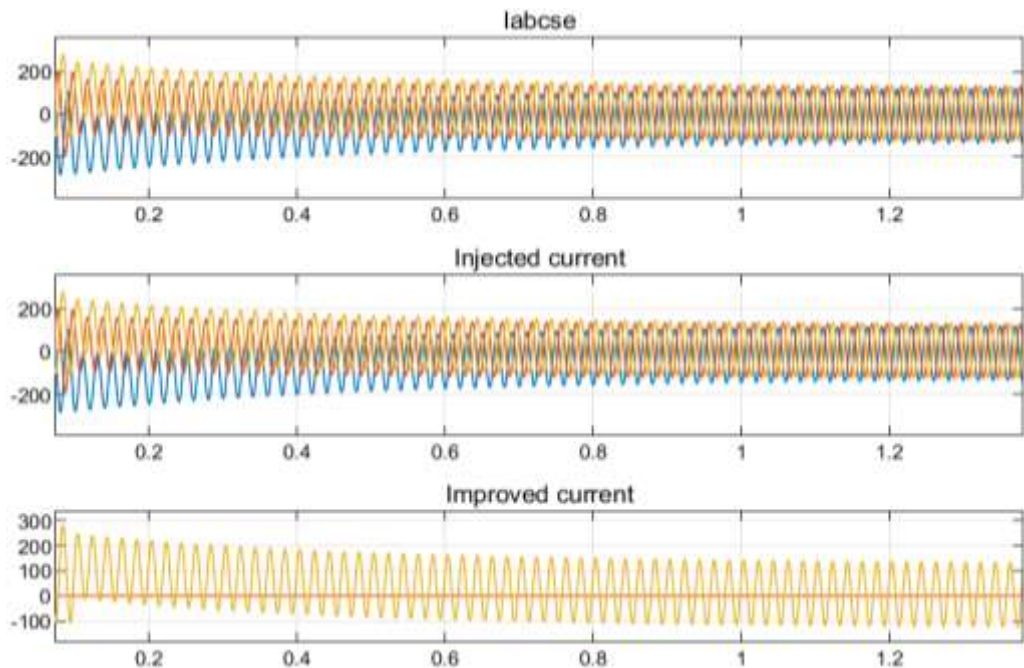

Fig.4.20: (a) Source Current at No Load (b) Injected Current by Inverter at No Load (c) Improved Current at No Load

In this case, power production from a renewable source is continuous but the load is zero. A significant change is observed in the load current at no-load condition. After 0.6 seconds output becomes constant as shown in Fig.4.20(c). Improved current has fewer harmonics as compared to the source current and the whole system is reliably productive. The source current waveforms and shunt inverter output waveforms are shown in Fig.4.20(a) and Fig.4.20(b) respectively.

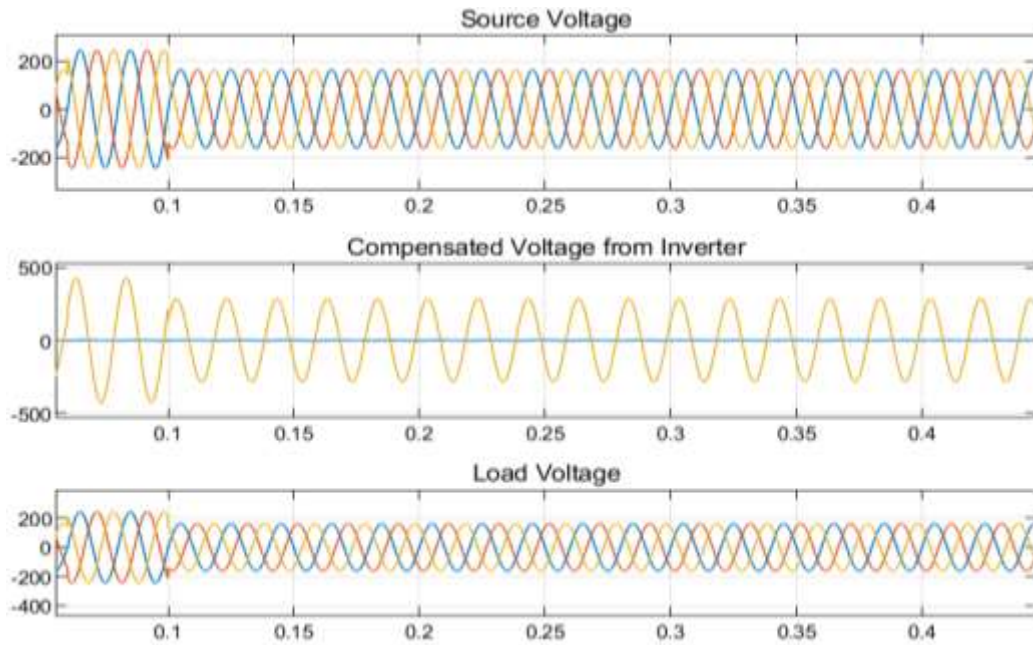

Fig.4.21: (a) Source Voltage at No Load (b) Injected Voltage by Series Inverter at No Load (c) Improved Voltage at No Load

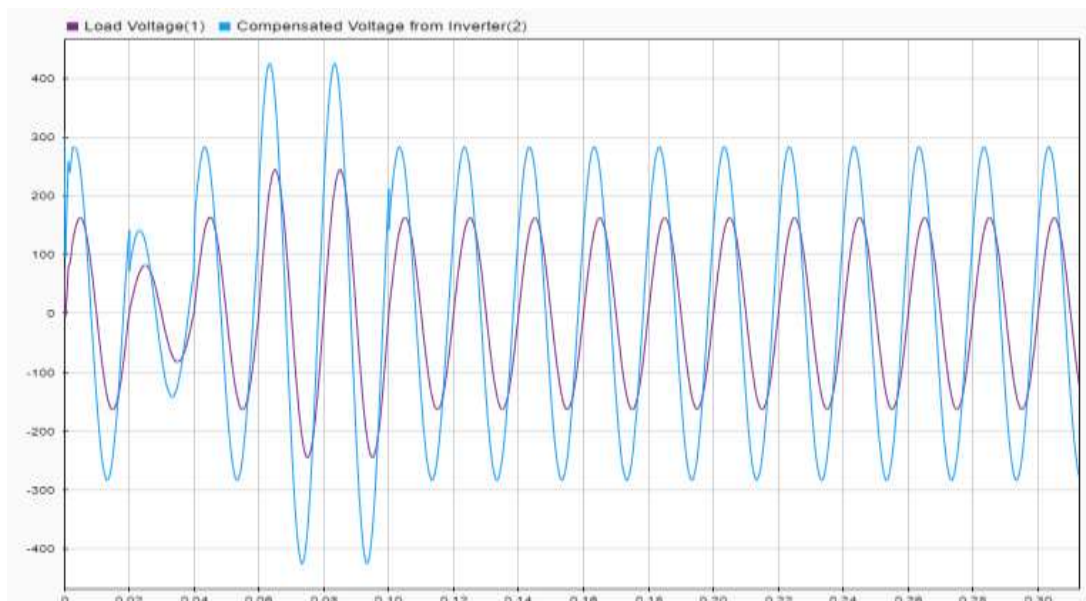

Fig.4.22: Simulation Data Inspector of Load Voltage and Compensated The voltage at No Load Conditions

The voltage behaviour at no load is shown in Fig.4.21 which seems to be stable while the Fig.4.22 demonstrates the comparative real-time nature of Simulation Data Inspector for load voltage and injected voltage by the series compensator of UPQC.

4.5.6 Case VI-Load is Very High and Generation of Power is Continuous

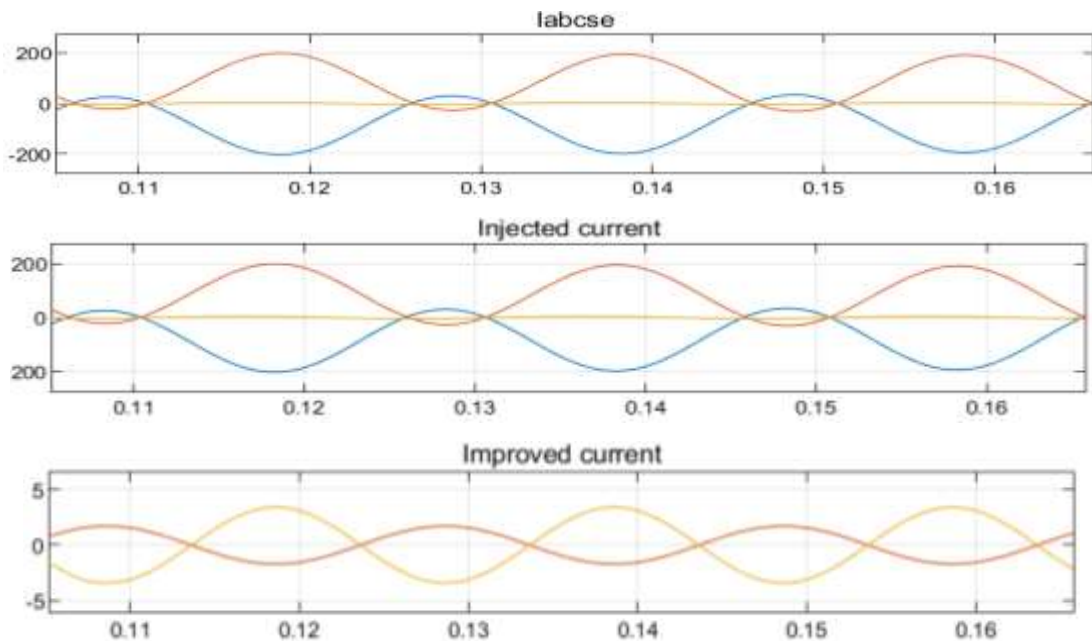

Fig.4.23: At High Load Behaviour of (a) Source Current (b) Injected Current by Shunt Inverter (c) Improved Current

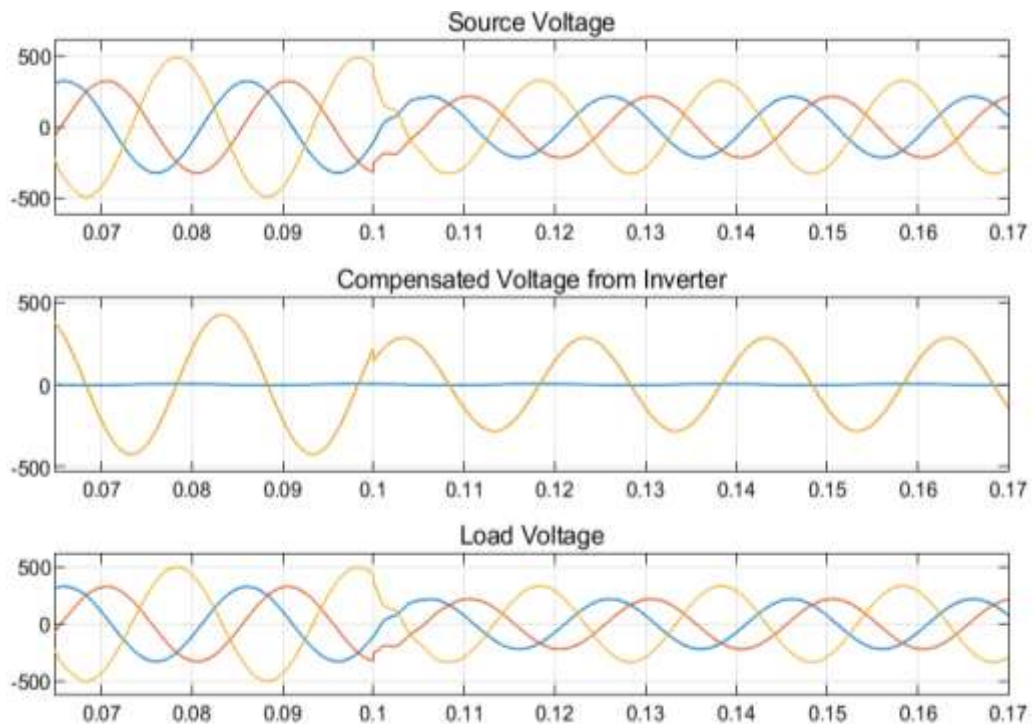

Fig.4.24: At High Load Behaviour of (a) Source Voltage (b) Injected Voltage by Shunt Inverter (c) Improved Voltage

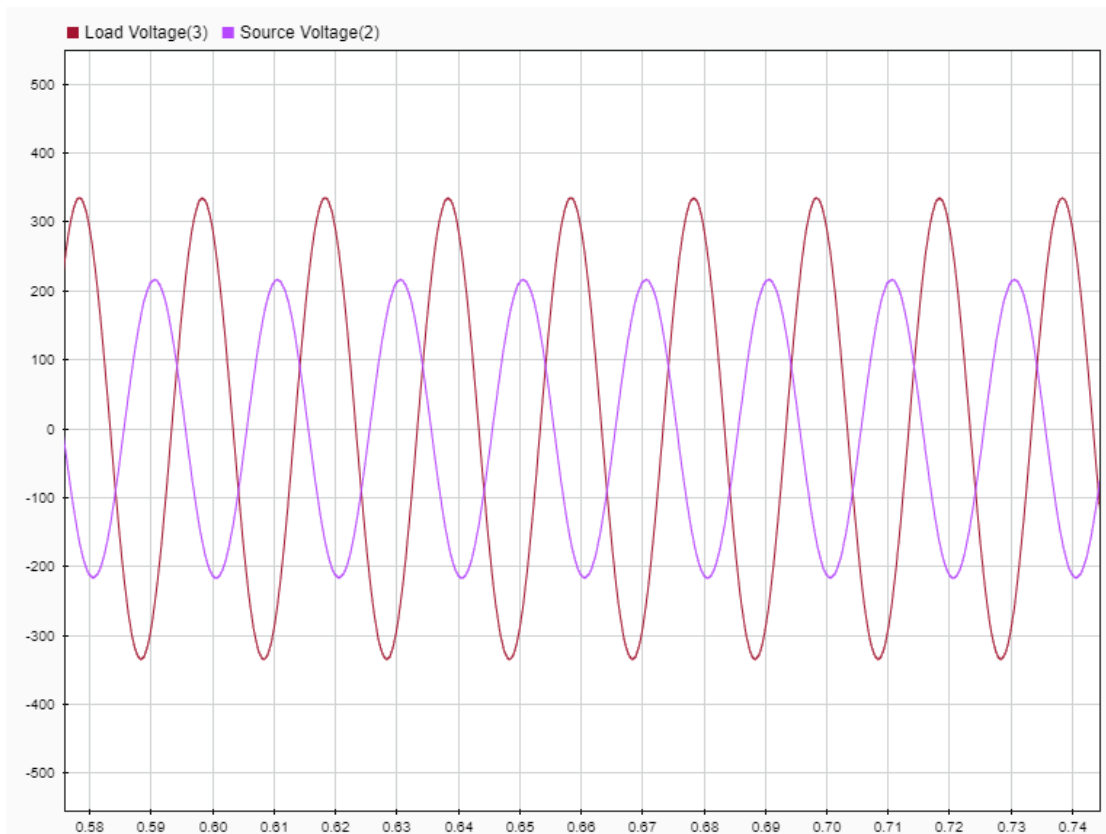

Fig.4.25: Simulation Data Inspector of Load Voltage and Compensated Voltage at High Load Conditions

In this case, the load is behaviour at high load is shown in Fig.4.24 which seems to be stable while the Fig.4.23 shows the that High Load Behaviour of (a) Source Current (b) Injected Current by Shunt Inverter (c) Improved Current of the proposed system with respect to time (X-axis) where resistance is taken about 1000Ω and inductance of about $20e-3$ H.

Fig.4.25 illustrates the comparative real-time nature of Simulation Data Inspector for load voltage and source voltage by the series compensator of UPQC at high load state of the proposed system. The Voltage is very high and it may be supplied by the PV-UPQC integrated system.

4.6 Performance of PV-UPQC under Steady-State Condition

The Fig.4.28 and Fig.4.29 demonstrate the performance of PV-UPQC system during nominal conditions and Fig.4.26 presents the behaviour of current after coming out of the series transformer and passing through a series resistor and inductor. This current

is supplied to the series active power filter. The waveforms of voltage in the series transformer which is injected in the series active filter are presented in Fig.4.27.

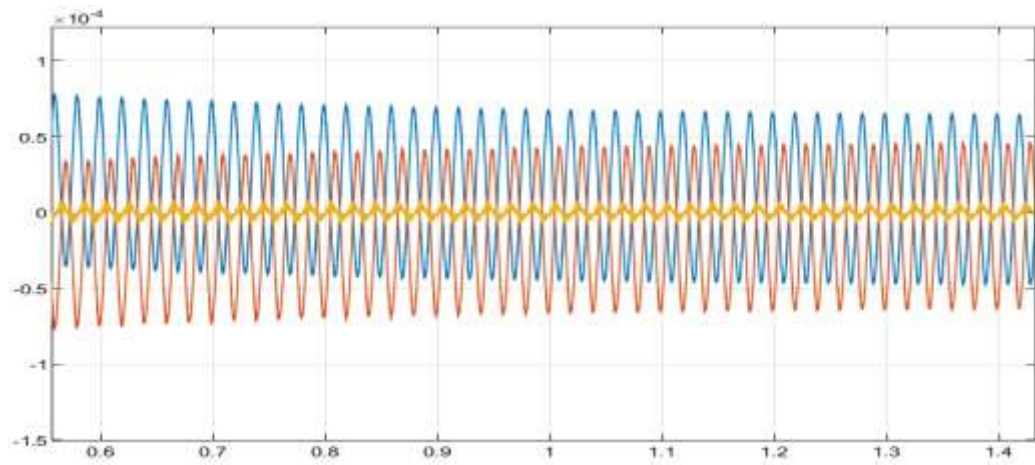

Fig.4.26: Current supplied to the Series Active Filter of UPQC

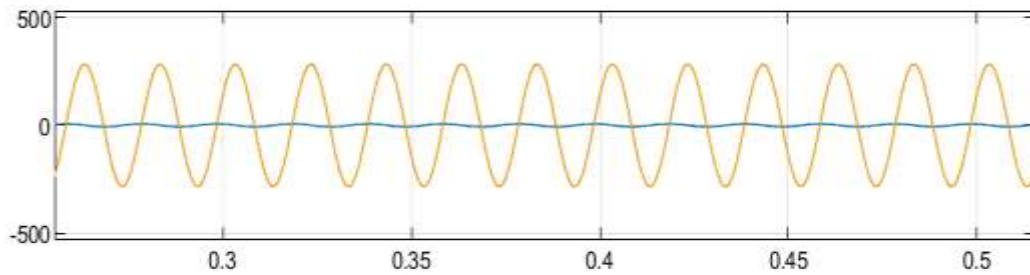

Fig.4.27: Voltage supplied to the Series Active Filter of UPQC

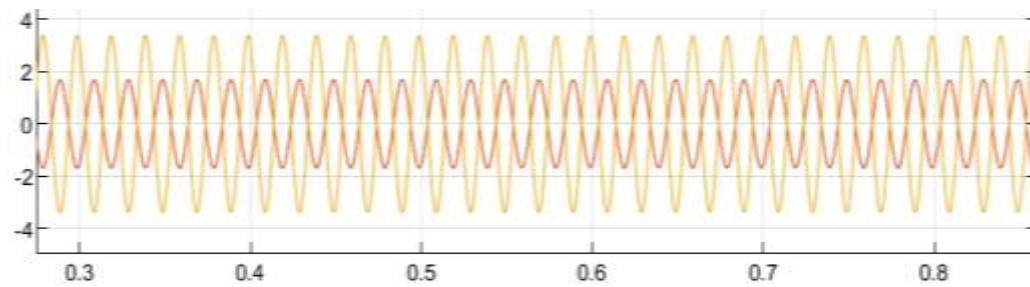

Fig. 4.28: Load current Behaviour in Steady-State Condition

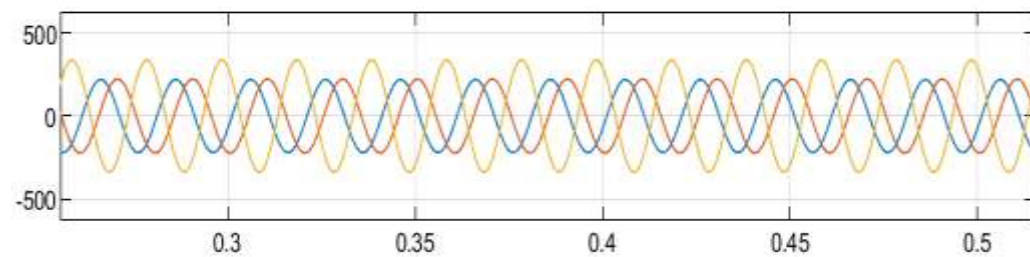

Fig. 4.29: Load voltage Behaviour in Steady-State Condition

The output of filtered current from shunt active power filter is illustrated in Fig.4.28 under nominal conditions respect to time (X-axis) while the output behaviour of load voltage diagnosed by the series active filter is shown in Fig.4.29 under steady-state conditions.

4.7 Total Harmonic Distortion (THD) Calculation

As shown in Fig.4.30, the load current is reduced to an effective percentage of 0.04% and while voltage THD is reduced to 0.29% according to Fig.4.31 in FET Analysis.

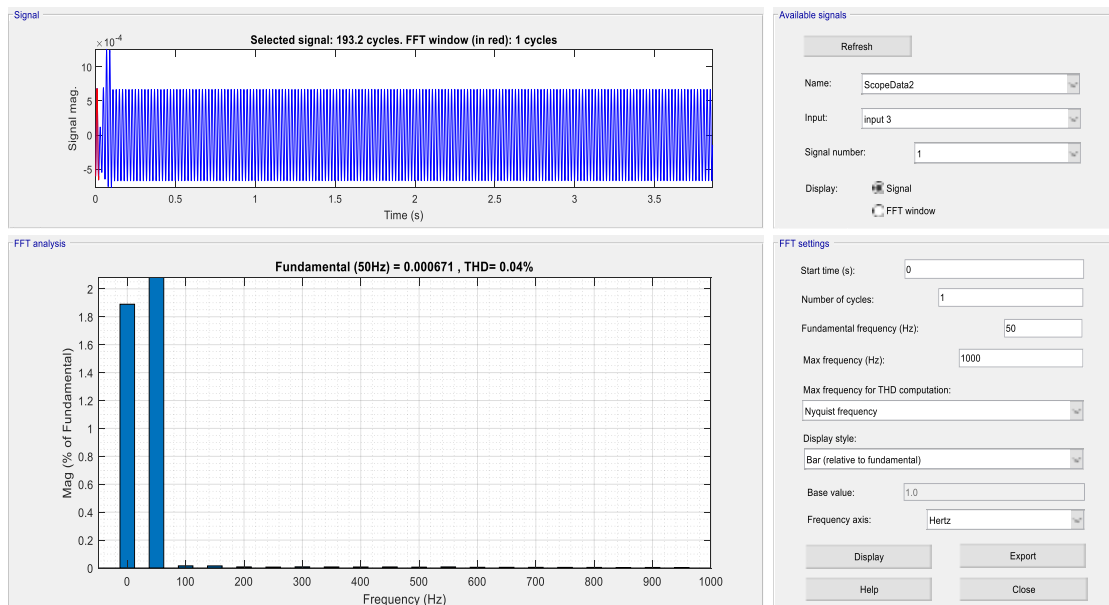

Fig.4.30: FET Analysis of Load Current of PV-UPQC System

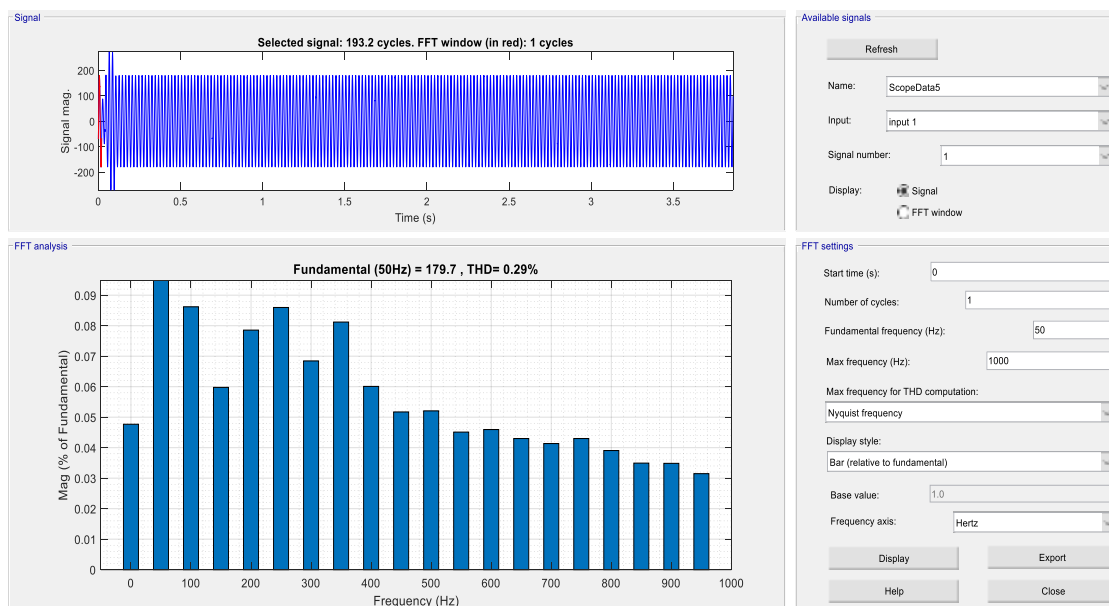

Fig.4.31: FET Analysis of Load Voltage of PV-UPQC System

4.8 Comparative FET Analysis

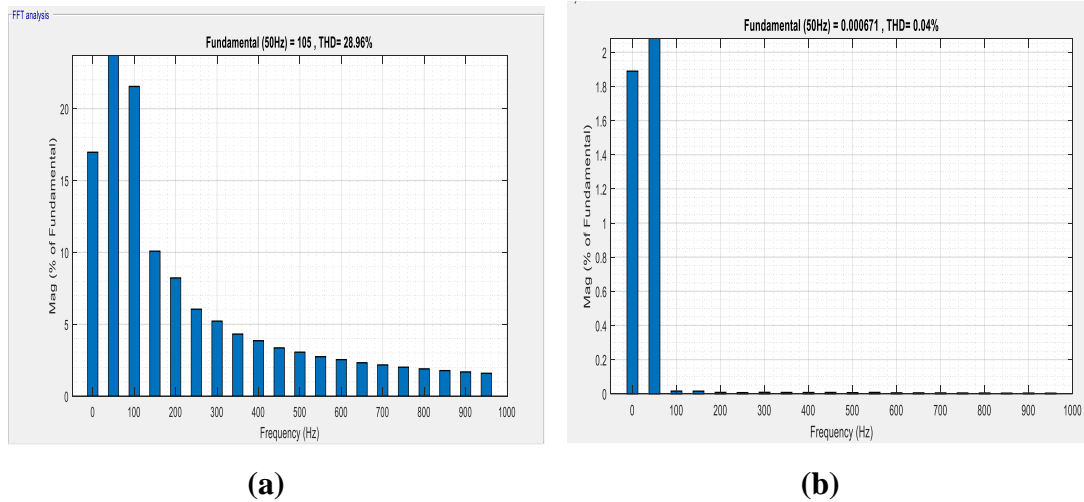

Fig.4.32: FET Analysis of Load Current (a) Before Filtering (b) After Filtering

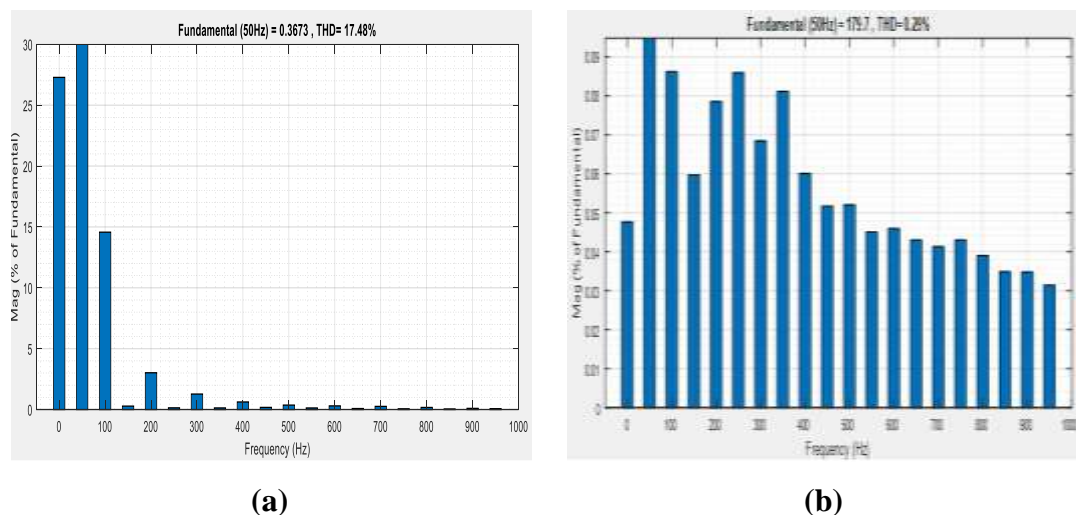

Fig.4.33: FET Analysis of Voltage (a) Before Filtering (b) After Filtering

The Comparative Study of load current simulation results has been discussed here. As after the implementation of Shunt Active harmonic filter load current has become nearly sinusoidal. The THD reduction in load current and voltage is seen from 28.96% to 0.04% and from 17.48 % to 0.29% as shown in Fig.4.32 and Fig.4.33 respectively which is in the range of IEEE 519 Standards.

4.9 Closure

A model of Unified Power Quality Conditioner which is based on shunt and series active filter is grid-connected PV system has been observed in MATLAB simulation results that UPQC improves the power quality of the system due to the elimination of

current harmonics and reactive current with a reduction in voltage harmonics. This makes the load current sinusoidal and in phase with the source voltage. The PV-UPQC system under various dynamic conditions has been evaluated to be stable. The steady-state condition performance of the proposed system is efficient. Waveforms of load current and load voltage after filtering is recorded with less interruptions. THD reduction in source current is seen from 28.96% to 0.04% for current and 17.48 % to 0.29% for the voltage which is in range of 519 IEEE Standards. The Three-Phase Confederated PV and UPQC system is a good solution for the present distribution system with power quality improvement.

CHAPTER – 5

CONCLUSION AND FUTURE SCOPE

5.1 Conclusion

A well-designed Unified Power Quality Conditioner (UPQC) have been used to improve power quality. The designed UPQC with Photovoltaic (PV) in the three-phase system is simulated in MATLAB and results are recorded. From the investigation following conclusions are made-

- Modelling of Three-Phase Confederated PV and UPQC is done and a dynamic model is developed in MATLAB-Simulink and brilliantly simulated.
- Unified Power Quality Conditioner with series-shunt active is successfully designed.
- The control strategies of the working of the active filters in UPQC have been studied.
- The load current and load voltage Total Harmonic Distortion (THD) of the Three-Phase PV System with and without UPQC system is compared. The THD reduction in load current is seen from 28.96% to 0.04% and THD reduction in load voltage is recorded from 17.48% to 0.29% which is in the range of IEEE 519 Standards.
- The designed model of Three-Phase Confederated PV and UPQC mitigate the current harmonics and voltage interruptions as well as satisfies the IEEE519 harmonic standards, being verified from simulated results using MATLAB.
- The designed system seemed to be stable under various dynamic conditions and steady-state conditions.
- The system so designed improves the power quality of the clean energy generated by the photovoltaic array.

5.2 Future Scope

- For future research, Artificial Intelligence with Neural and Fuzzy Logics can be implemented in the active power filter.
- Better performance of harmonic compensation can also be expected in future by the use of Space Vector Modulation Technique where Hysteresis Controller can be used effectively.

- Notch Filter can also be used for the same purpose and better dynamic response.
- The future holds the gateway to develop a well-functioning PV-Wind Hybrid UPQC system. Inverters can be designed which injects the PV-Wind Power either to load or to utility grids lines and can simultaneously fulfil the functions of Active Power Filters.
- Micro-Controllers UPQC can also be used in future with effectiveness. The PV-UPQC integrated system can also be designed with series inverters for better efficiency.

The future of UPQC is bright with the responsibility of better improvement in power quality.

LITERATURE CITED

- Agarwal, R.K., Hussain, I. and Singh, B. 2017. Three-phase single-stage grid-tied solar pv ecs using pll-less fast ctf control technique. *IET Power Electronics* **10** : 178-188.
- Akagi, H. and Kondo, R. 2010. A transformer-less hybrid active filter using a three-level pulse width modulation (pwm) converter for a medium-voltage motor drive. *IEEE Transactions on Power Electronics* **25** : 1365-1374.
- Alam, M.J.E., Muttaqi, K.M. and Sutanto, D. 2014. An approach for online assessment of rooftop solar pv impacts on low-voltage distribution networks. *IEEE Transactions on Sustainable Energy* **5** : 663-672.
- Aredes, M., Heumann, K. and Hafner, J. 1997. Three-phase four-wire shunt active filter control strategies. *IEEE Transactions on Power Electronics* **22** : 311-318.
- Barbi, I. and Pini, S.H. 2011. A single-phase high-power-factor rectifier, based on a two-quadrant shunt active filter. *IEEE Transactions on Power Electronics* **26** : 3131-3143.
- Basu, M., Das, S.P., and Dubey, G.K. 2008. Investigation on the performance of upqc-q for voltage sag mitigation and power quality improvement at a critical load point. *IET Journals & Magazines on Generation, Transmission & Distribution* **2** : 414-423.
- Borse, N.S. and Shembekar, S.M. 2016. Power quality improvement using dual topology of upqc. In : *International IEEE Conference on Global Trends in Signal Processing, Information Computing and Communication (ICGTSPICCC)* held at Jalgoan, India during December 22-24, 2016, pp. 428-431.
- Campanhol, L.B.G., Silva, S.A.O., Oliveira, A.A. and Bacon, V.D. 2019. Power flow and stability analyses of a multifunctional distributed generation system integrating a photovoltaic system with unified power quality conditioner. *IEEE Transactions on Power Electronics* **34** : 6241-6256.

- Casadei, D., Grandi, G. and Rossi, C. 2006. Single-phase single-stage photovoltaic generation system based on a ripple correlation control maximum power point tracking. *IEEE Transactions on Energy Conversion* **21** : 562-568.
- Chang, G.W. and Chen, W.C. 2006. A new reference compensation voltage strategy for series active power filter control. *IEEE Transactions on Power Delivery* **21** : 1754-1756.
- Choudhury, S.R., Das, A., Anand, S., Tungare, S., and Sonawane, Y. 2019. Adaptive shunt filtering control of upqc for increased nonlinear loads. *IET Journals & Magazines on Power Electronics* **12** : 330-336.
- Devassy, S. and Singh, B. 2018. Design and performance analysis of three-phase solar pv integrated upqc. *IEEE Transactions on Industry Applications* **54** : 73-81.
- Esrarn, T. and Chapman, P.L. 2007. Comparison of photovoltaic array maximum power point tracking techniques. *IEEE Transactions on Energy Conversion* **22** : 439-449.
- Fang, Z., Longhui, W., Pengbo, Z., Hongyu, L. and Zhaoan, W. 2007. Study on the influence of supply-voltage fluctuation on shunt active power filter. *IEEE Transactions on power delivery* **22** : 1743-1749.
- Fujita, H. and Akagi, H. 1998. The unified power quality conditioner: the integration of series and shunt active filters. *IEEE Transactions Power Electronics* **13** : 315-332.
- Ganguly, S. and Lakshmi, S. 2018. Modelling and allocation of open-upqc-integrated pv generation system to improve the energy efficiency and power quality of radical distribution networks. *IET Journals & Magazines of Renewable Power Generation* **12** : 605-613.
- Geibel, D., Appen, J.V., Braun, M., Stetz, T. and Diwold, K. 2013. Time in the sun: the challenge of high pv penetration in the german electric grid. *IEEE Power and Energy Magazine* **11** : 55-64.
- Golestan, S., Ramezani, M., Guerrero, J.M. and Monfared, M. 2015. Dq-frame cascaded delayed signal cancellation-based pll: Analysis, design, and comparison with moving average filter-based pll. *IEEE Transactions on Power Electronics* **30** : 1618-1632.

- Guerrero, J.M., Loh, P.C., Lee, T.L. and Chandorkar, M. 2013. Advanced control architectures for intelligent micro-grids; part ii: power quality, energy storage, and ac/dc microgrids. *IEEE Transactions on Industrial Electronics* **60** : 1263-1270.
- Han, B., Bae, B. Baek, S. and Jang, G. 2006. New configuration of upqc for medium-voltage application. *IEEE Transactions on Power Delivery* **21** : 1438-1444.
- Javadi, A., Hamadi, A., Woodward, L. and Haddad, L. 2016. Experimental investigation on a hybrid series of active power compensator to improve the power quality of typical households. *IEEE Transactions Industrial Electronics* **63** : 4849-4859.
- Jindal, A.K., Ghosh, A. and Joshi, A. 2007. Interline unified power quality conditioner. *IEEE Transactions Power Delivery* **22** : 364-372.
- Karimi, M., Mokhlis, H., Naidu, K., Uddin, S. and Bakar, A. 2016. Photovoltaic penetration issues and impacts in distribution network : a review. *Renewable and Sustainable Energy Reviews* **53** : 594-605.
- Kim, S. and Enjeti, P.N. 2002. A new hybrid active power filter (apf) topology. *IEEE Transactions on Power Electronics* **17** : 48-54.
- Khadem, S.K., Basu, M. and Conlon, M.F. 2015. Intelligent islanding and seamless reconnection technique for microgrid with up. *IEEE Journal of Emerging and Selected Topics in Power Electronics* **3** : 483-492.
- Khadkikar, V. and Chandra, A. 2011. Upqc-s: a novel concept of simultaneous voltage sag/swell and load reactive power compensations utilizing series inverter of upqc. *IEEE Transactions On Power Electronics* **26** : 2414-2425.
- Liu, X., Aichhorn, A., Liu, L. and Li, H. 2012. Coordinated control of distributed energy storage system with tap changer transformers for voltage rise mitigation under high photovoltaic penetration. *IEEE Transactions Smart Grid* **3** : 897-906.
- Medina-Rios, A. and Ramos-Carranza, H.A. 2007. An active power filter in phase coordinates for harmonic mitigation. *IEEE Transactions on Power Delivery* **22** : 1991-1993.

- Malekpour, A.R., Pahwa, A. and Natarajan, B. 2018. Hierarchical architecture for integration of rooftop pv in smart distribution systems. *IEEE Transactions on Smart Grid* **9** : 2019-2029.
- Mattavelli, P. 2001. A closed-loop selective harmonic compensation for active filters. *IEEE Transactions Industry Applications* **37** : 81-89.
- Mohammadi, H.R., Varjani, A.Y. and Mokhtari, H. 2009. Multiconverter unified power quality conditioning system: mc-upqc. *IEEE Transactions on Power Delivery* **24** : 1679-1686.
- Mohan, P. and Krishna, V. 2016. Design and analysis of upqc with dg for mitigating power quality issues. In : *International Conference on Energy Efficient Technologies for Sustainability (ICEETS)* held at Nagercoil, India during April 7-8, 2016, pp. 101-105.
- Ovaska, S.J. and V`aliviita, S. 1998. Delayless method to generate current reference for active filters. *IEEE Transactions on Industrial Electronics* **45** : 559-567.
- Palanisamy, K., Kothari, D., Mishra, M.K., Meikandashivam, S. and Ragland, I.J. 2013. Effective utilization of unified power quality conditioner for interconnecting pv modules with a grid using a power angle control method. *International Journal of Electrical Power and Energy Systems* **48** : 131-138.
- Parchure, A., Tyler, S.J., Peskin, M.A., Rahimi, K., Broadwater, R.P. and Dilek, M. 2017. Investigating pv generation induced voltage volatility for customers sharing a distribution service transformer. *IEEE Transactions Industry Applications* **53** : 71-79.
- Quan, H., Li, B., Xiu, X. and Hui, D. 2017. Impact analysis for high-penetration distributed photovoltaic generation integrated into grid based on digsilent. In : *IEEE Conference on Energy Internet and Energy System Integration (EI2)* held at Beijing, China during November 26-28, 2017, pp. 1-6.
- Rahmani, S., Hamadi, A., Al-Haddad, K. and Dessaint, L.A. 2014. A Combination of Shunt Hybrid Power Filter and Thyristor-Controlled Reactor for Power Quality. *IEEE Transactions on Industrial Electronics* **61** : 2152-2164.

- Ramaswamy, P.C. and Deconinck, G. 2013. Impact of varying photovoltaic penetration on minimum loss reconfiguration. *In : IECON 2013 - 39th Annual Conference of the IEEE Industrial Electronics Society* held at Vienna, Austria during November 10-13, 2013, pp. 2069-2074.
- Rauf, A.M. and Khadkikar, V. 2015. Integrated photovoltaic and dynamic voltage restorer system configuration. *IEEE Transactions on Sustainable Energy* **6** : 400-410.
- Ray, P.K. and Dash, S.K. 2018. Design and modeling of single-phase pv-upqc scheme for power quality improvement utilizing a novel notch filter-based control algorithm: an experimental approach. *Arabian Journal for Science and Engineering* **43** : 3083-3102.
- Román, E., Alonso, R., Ibañez, P., Elorduizapatarietxe, S. and Goitia, D. 2006. Intelligent pv module for grid-connected pv systems. *IEEE Transactions on Industrial Electronics* **53** : 1066-1073.
- Salmeron, P., and Litran, S.P. 2010. Improvement of the electric power quality using series active and shunt passive filters. *IEEE Transactions on Power Delivery* **25** : 1058-1067.
- Sato, Y., and Kataoka, T. 1996. A current-type pwm rectifier with active damping function. *IEEE Transactions Industry Applications* **32** : 533-541.
- Senturk, O.S. and Hava, A.M. 2009. High-performance harmonic isolation and load voltage regulation of the three-phase series active filter utilizing the waveform reconstruction method. *IEEE Transactions on Industry Applications* **45** : 2030-2038.
- Singh, B., Jain, B., Goel, S., Chandra, A. and Haddad.al, K. 2016. A multifunctional grid-tied solar energy conversion system with an and based control approach. *IEEE Transactions on Industry Applications* **52** : 3663-3672.
- Singh, B., Jain, C. and Goel, S. 2014. The ilst control algorithm of single stage dual purpose grid-connected solar pv system. *IEEE Transactions Power Electronics* **29** : 5347-5357.

- Singh, B. and Devassy, S. 2017. Modified p-q theory based control of solar pv integrated upqc-s. *IEEE Transactions Industry Applications* **99** : 1-8.
- Singh, Y., Hussain, I., Singh, B. and Mishra, S. 2017. Single-phase solar grid interface system with active filtering using an adaptive linear combiner filter-based control scheme. *IET Generation Transmission Distribution* **11** : 1976-1984.
- Srinath, S. and Kumar, N.K. 2018. Integration of upqc with new converter transformer for power quality improvement. In : *National Power Engineering Conference (NPEC)* held at Madurai, India during March 9-10, 2018, pp. 1-6.
- Steinhart, H., Staiger, J. and Bosch, S. 2018. Predictive current control for an active power filter with lcl-filter. *IEEE Transactions on Industrial Electronics* **65** : 1-10.
- Subudhi, B. and Pradhan, R. 2013. A comparative study of maximum power point tracking techniques for photovoltaic power systems. *IEEE Transactions on Sustainable Energy* **4** : 89-98.
- Peng, F.Z. 1998. Application issues of active power filters. *IEEE Industry Applications Magazine* **4** : 21-30.
- Terciyanlı, A., Avcı, T., Yılmaz, I., Ermis, C., Kose, K.N., Açık, A., Kalaycıoğlu, A.S., Akkaya, Y., Çadircı, I. and Ermis, M. 2012. A current source converter-based active power filter for mitigation of harmonics at the interface of distribution and transmission systems. *IEEE Transactions on Industry Applications* **48** : 1374-1386.
- Tonkoski, R., Turcotte, D., and El-Fouly, T. H. M. 2012. Impact of high pv penetration on voltage profiles in residential neighbourhoods. *IEEE Transactions Sustainable Energy* **3** : 518-527.
- Velasco-Quesada, G., Guinjoan-Gispert, F., Piqué-López, R., Román-Lumbreras, M. and Conesa-Roca, A. 2009. Electrical pv array reconfiguration strategy for energy extraction improvement in grid-connected pv systems. *IEEE Transactions on Industrial Electronics* **56** : 4319-4331.

- Waghmare, V.B. and Kadam, R.J. 2017. A modified upqc topology with reduced dc link voltage in power system. *In : International Conference on Intelligent Sustainable Systems (ICISS)* held at Palladum, India during December 7-8, 2017, pp. 756-758.
- Wang, Y., Joos, G. and Jin., J. 1997. Dc-side shunt-active power filter for phase-controlled magnet-load power supplies. *IEEE Transactions Power Electronics* **12** : 765-771.
- Wu, T.F., Nien, H.S., Shen, C.L. and Chen. 2005. A single-phase inverter system for pv power injection and active power filtering with non-linear inductor consideration. *IEEE Transactions Industry Applications* **41** : 1075-1083.
- Yang, Y., Enjeti, P., Blaabjerg, P. and Wang, H. 2015. Wide-scale adoption of photovoltaic energy: grid code modifications are explored in the distribution grid *IEEE Industry Application Magazine* **5** : 21-3.
- Yeves, F., Martínez, S. and Barrero, F. 2000. Active power filters for line conditioning: a critical evaluation. *IEEE Transactions on Power Delivery* **22** : 319-325.
- Zare, F., Mazumder, S. and Ghosh, A. 2013. Voltage quality improvement in distribution networks containing ders using upqc. *In : IEEE Conference on Power and Energy Society General Meeting* held at Vancouver, BC, Canada during July 21-25, 2013, pp. 1932-5517.
- Zhaoan, W., Jun, Y. and Guanyuan, Q. 1996. Dc-side voltage control of shunt active power filter. *IEEE Transactions Power Electronics* **4** : 48-50.

APPENDIX-I

Some of the International Electrotechnical Commission (ICE) standards to define harmonic limit values are followings-

IEC/EN 61000-3-2 Limits for harmonic current emissions

IEC/EN 61000-3-2 Limits for harmonic current

EN61000-4-7 Guide on harmonics and inter-harmonics measurements

EN 61000-3-2 For harmonic current control for all electronic components

Some of the International Electrotechnical Commission (ICE) standards to define Photovoltaic System values are followings-

IEC 60146-1 Semiconductor Convertors – General requirements and line commutated converters

ICE 60364-7-712 Electrical Installations of buildings – Requirements for special installation or locations – Solar photovoltaic power supply systems

IEC 60891 Procedures for temperature and irradiance corrections to measured I-V Characteristics

IEC 60904-1 Measurements of photovoltaic current-voltage characteristics

IEC 60904-2 Requirements for reference solar devices

IEC 60904-4 Reference solar devices-Procedures for establishing calibration Traceability

IEC 61683 Photovoltaic system – Power conditioners – Procedure for measuring the efficiency

IEC 62548 Design requirements for Photovoltaic arrays

APPENDIX-II
Experimental Parameters

Snubber Resistance of Active Filter R_s (Ohms)	2e5
Parallel Strings in PV array	4
Series connected Module per String	10
Snubber Resistance of Boost Converter R_s (Ohms)	1e5
The resistance of Diode R_{on} (Ohms)	1e-4
Minimum Frequency of PLL used in Series Active Filter Controller (Hz)	45
Inductance connected after Three-Phase voltage source (H)	4e-3
The nominal voltage used for pu measurement (V_{rms} phase-phase)	400
Resistance connected after three-phase voltage source R (Ohms)	0.01
Load Resistance (Ohms)	100
Load Inductance (H)	20e-3
Resistance of Active Filter R_{on} (Ohms)	1e-3
Loop filter proportional gain of 3-phase discrete PLL used in Hysteresis Controller	200
Loop filter integral gain of 3-phase discrete PLL used in Hysteresis Controller	2000
Sample time of 3-phase discrete PLL used in Hysteresis Controller	-1
Switch on point of Relay used in Hysteresis Controller	0.1
Switch off point of Relay used in Hysteresis Controller	-0.1

Output when one of Relay used in Hysteresis Controller	1
Cut-off frequency of Low pass Filter used in Hysteresis Controller of Shunt Active Filter (Hz)	25
Damping factor Zetaof Low pass Filter used in Hysteresis Controller of Shunt Active Filter (Hz)	0.707

PUBLICATION

Yashvi Mudgal and Vinod Kumar Yadav, “Inspection of Confederated Three-Phase Photovoltaic and Unified Power Quality Conditioner Configuration”, *International Journal for Scientific Research and Development (IJSRD)*, Volume 7, Issue 5, July 2019. (ISSN: 2321-0613)

ABSTRACT

The environmental protection with power generation of an acceptable level of reliability, quality and safety is the need of the modern generation. Recent advancement in technology which includes effective power production and simultaneous utilization of renewable energy resources. The rooftop installed Photovoltaic (PV) system has gained much popularity due to the great potential to supply clean energy with minimum impact on the environment.

The PV energy sources have discontinuous nature which leads to voltage quality problems as well as the advancement of semiconductor tends to increase the level of current harmonic distortion. Power quality issues at load side are the most common problem which creates huge unbalance on transmission and generation side of the system. As the problems related to power quality is going to take newer dimensions power quality improvement technique of Unified Power Quality Conditioner is used in the proposed thesis. The energy supply from PV is transferred to the Unified Power Quality Conditioner (UPQC) for conditioning. Active Power Filter gives a promising solution to compensate for the adverse effects of harmonics and reactive power compensation by suitable control strategies. In UPQC, Shunt Active Filter is used to mitigate current harmonics while the Series Active Power Filter has been used to reduce the voltage interruptions. Integrating the photovoltaic array along with UPQC has an advantage of pollution-free energy generation along with the surety of high levels of power quality. Synchronous Reference Frame (SRF) is used as a control technique with hysteresis based current control to obtain switching signals in the shunt compensator while Phase Locked Loop (PLL) is used for series active power filter.

To verify the objective of power quality, dynamic model of Confederated Three-Phase PV-UPQC analysis is simulated in MATLAB-Simulink software under different conditions. The performance evaluation shows that efficient results were observed and considered effective for the system. The MATLAB simulation results reveal that the designed Unified Power Quality Conditioner with photovoltaic array effectively mitigate the current and voltage harmonics and is in compliance with the IEEE519 recommended harmonic standards.

सारांश

विश्वसनीयता, गुणवत्ता और सुरक्षा के एक स्वीकार्य स्तर की बिजली उत्पादन के साथ पर्यावरण संरक्षण आधुनिक पीढ़ी की आवश्यकता है। प्रौद्योगिकी में हाल की उन्नति जिसमें प्रभावी बिजली उत्पादन और नवीकरणीय ऊर्जा संसाधनों का एक साथ उपयोग शामिल है। छत पर स्थापित फोटोवोल्टिक (पीवी) प्रणाली ने पर्यावरण पर न्यूनतम प्रभाव के साथ स्वच्छ ऊर्जा की आपूर्ति करने की बढ़ी क्षमता के कारण बहुत लोकप्रियता हाँसिल की है।

पीवी ऊर्जा स्रोतों में असंतोषजनक प्रकृति है जो वोल्टेज गुणवत्ता की समस्याओं की ओर जाता है और साथ ही अर्द्धचालक की प्रगति से वर्तमान हार्मोनिक विरूपण के स्तर को बढ़ाता है। लोड साइड में बिजली की गुणवत्ता की समस्या सबसे आम समस्या है जो सिस्टम के प्रसारण और पीढ़ी के पक्ष में भारी असंतुलन पैदा करती है। चूंकि बिजली की गुणवत्ता से संबंधित समस्याएं नए आयामों को लेने जा रही हैं, प्रस्तावित थीसिस में यूनिफाइड पावर क्वालिटी कंडीशनर की पावर क्वालिटी सुधार तकनीक का उपयोग किया जाता है। पीवी के ऊर्जा की आपूर्ति कंडीशनिंग के लिए यूनिफाइड पावर क्वालिटी कंडीशनर (UPQC) में स्थानांतरित हो जाती है। सक्रिय पावर फ़िल्टर उपयुक्त नियंत्रण रणनीतियों द्वारा हार्मोनिक्स और प्रतिक्रियाशील बिजली मुआवजे के प्रतिकूल प्रभावों की भरपाई के लिए आशाजनक समाधान देता है। UPQC में, शंट सक्रिय फिल्टर का उपयोग वर्तमान हार्मोनिक्स को कम करने के लिए किया जाता है, जबकि वोल्टेज को कम करने के लिए श्रृंखला सक्रिय पावर फिल्टर का उपयोग किया गया है। UPQC के साथ फोटोवोल्टिक सारणी को एकीकृत करने से उच्च स्तर की बिजली की गुणवत्ता के साथ-साथ प्रदूषण मुक्त ऊर्जा उत्पादन का लाभ होता है। सिंक्रोस रेफरेंस फ्रेम (SRF) का उपयोग हिस्टैरिसिस आधारित वर्तमान नियंत्रण के साथ शंट कम्पेंसेटर में स्विचिंग सिग्नल प्राप्त करने के लिए नियंत्रण तकनीक के रूप में किया जात है, जबकि फेज़ लॉकड लूप (PLL) का उपयोग श्रृंखला सक्रिय पावर फिल्टर के लिए किया जाता है।

बिजली की गुणवत्ता के उद्देश्य को सत्यापित करने के लिए कन्फेडरेटेड थ्री-फेस PV-UPQC विश्लेषण के डायनामिक मॉडल को MATLAB-Simulink सॉफ्टवेयर में विभिन्न अवस्थाओं में तैयार किया गया है। सिस्टम के लिए प्रभावी और कुशल परिणामों के आधार पर प्रदर्शन का मूल्यांकन किया गया है। MATLAB-Simulink के परिणामों से पता चलता है कि फोटोवोल्टिक सारणी के साथ डिज़ाइन किए गए एकीकृत पावर क्वालिटी कंडीशनर प्रभावी रूप से वर्तमान और वोल्टेज हार्मोनिक्स को कम करते हैं और IEEE 519 अनुशासित हार्मोनिक मानकों के अनुपालन में हैं।