

**DEVELOPMENT AND
PERFORMANCE EVALUATION OF
MANUALLY OPERATED FINGER WEEDER**

By

JAGRITI CHOUDHARY

(Registration No. 2050220007)

B. Tech. (Agril. Engg.)



**DEPARTMENT OF FARM MACHINERY AND POWERENGINEERING
COLLEGE OF AGRICULTURAL ENGINEERING AND TECHNOLOGY**

JUNAGADH AGRICULTURAL UNIVERSITY

JUNAGADH – 362001

OCTOBER - 2022

**DEVELOPMENT AND
PERFORMANCE EVALUATION OF
MANUALY OPERATED FINGER WEEDER**

**A THESIS SUBMITTED TO
JUNAGADH AGRICULTURAL UNIVERSITY
IN PARTIAL FULFILMENT OF THE REQUIREMENTS
FOR THE AWARD OF THE DEGREE OF**

MASTER OF TECHNOLOGY

(Agricultural Engineering)

IN

FARM MACHINERY AND POWER ENGINEERING

BY

JAGRITI CHOUDHARY

(Registration No. 2050220007)

B. Tech. (Agril. Engg.)



**DEPARTMENT OF FARM MACHINERY AND POWER ENGINEERING
COLLEGE OF AGRICULTURAL ENGINEERING AND TECHNOLOGY
JUNAGADH AGRICULTURAL UNIVERSITY**

JUNAGADH – 362001

OCTOBER - 2022

**DEPARTMENT OF FARM MACHINERY AND POWER ENGINEERING
COLLEGE OF AGRICULTURAL ENGINEERING AND TECHNOLOGY
JUNAGADH AGRICULTURAL UNIVERSITY, JUNAGADH – 362001**

Name of Student

Major Guide

Jagriti Choudhary

Dr. T. D. Mehta

**DEVELOPMENT AND
PERFORMANCE EVALUATION OF
MANUALLY OPERATED FINGER WEEDER**

ABSTRACT

Key words: *Finger weeder; performance evaluation; weeding efficiency; weeding; manual weeder; ergonomics.*

Both conventional and organic agricultural production techniques compete greatly with weeds. The presence of weeds generally results in a 31.5% reduction in crop yields, with 22.7 percent of that reduction occurring in the winter and 36.5% in the summer and kharif seasons. A single tool cannot effectively control weeds. In India, weeds cause an average annual loss of Rs. 1,980 Crores. Mechanical weeding, burning, biological control, chemical control, and farming practises are the different means to control weeds. After learning that tools like cutlasses and hoes need more effort, time and labour, this work involves developing of a mechanised weeder. The mechanical weeder was designed as an answer to these issues. According to data on human material handling, pushing an object is more convenient than pulling it. Developed weeder is of the push type. Pushing the weeder causes the least amount of plant damage and won't strain your arms or body. The weeder was built and assessed using both men's and women's anthropometric data, keeping in mind that, women perform the majority of agricultural work, particularly weeding. With the help of the load indicator between the handle, the operator's push is directly measured. To maintain its stability while weeding, the weeder was provided two wheels. Three operators were selected at random for the experiment from the workplace. The evaluation of ergonomic characteristics included heart rate, oxygen consumption rate and energy expenditure.

Groundnut and blackgram were the crop plants chosen for the field trial. The bulk density and moisture content of the soil were 1.64 and 1.65 g/cm³ and 17.15 and 20 percent, respectively in groundnut and blackgram field. At 0.55 km/h operating speed the developed finger weeder had a highest effective field capacity of 0.038 ha/h, field efficiency of 95.74 %, draft of 11.8 kg, power of 0.022 hp, weeding efficiency of 82.22 % and BMI of 22.77 kg/m². According to an economic analysis, the cost of weeding per hectare was found to be Rs.1109.11/- and Rs. 1147.8/- in groundnut and blackgram field respectively. Therefore, it is advised that a newly developed push type manual twin wheel finger weeder can be used for weeding by both male and female operator.

**COLLEGE OF AGRICULTURAL ENGINEERING AND
TECHNOLOGY
JUNAGADH AGRICULTURAL UNIVERSITY
JUNAGADH**

CERTIFICATE – I

This is to certify that the thesis entitled “**DEVELOPMENT AND PERFORMANCE EVALUATION OF MANUALLY OPERATED FINGER WEEDER**” submitted by **Ms. JAGRITI CHOUDHARY** (Reg. No. 2050220007) in partial fulfilment of the requirements for the award of the degree of **MASTER OF TECHNOLOGY (AGRICULTURAL ENGINEERING)** in the subject of **FARM MACHINERY AND POWER ENGINEERING** to the Junagadh Agricultural University is a record of bonafide research work carried out by her under my guidance and supervision and the thesis has not previously formed the basis for the award of any degree, diploma or other similar title. The candidate had fulfilled all prescribe requirements. The assistance and help received during the course of investigation have been fully acknowledged. She has successfully completed the comprehensive/ preliminary examination held on **April 28, 2022** as required under the regulation for post-graduate studies. She has submitted kachcha bound thesis on **July 29, 2022**.

Place: Junagadh
Date: 29/ 07/ 2022

(Dr. T. D. Mehta)
Major guide and
Associate professor
Dept. of FMPE, CAET
JAU, Junagadh



**COLLEGE OF AGRICULTURAL ENGINEERING AND TECHNOLOGY
JUNAGADH AGRICULTURAL UNIVERSITY
JUNAGADH**

CERTIFICATE – II

Date: 07/10/2022

This is to certify that the thesis entitled “**DEVELOPMENT AND PERFORMANCE EVALUATION OF MANUALLY OPERATED FINGER WEEDER**” submitted by **Ms. JAGRITI CHOUDHARY (Reg. No. 2050220007)** to Junagadh Agricultural University, Junagadh in partial fulfilment of the requirements for award of the degree of **MASTER OF TECHNOLOGY (AGRICULTURAL ENGINEERING)** in the subject of **FARM MACHINERY AND POWER ENGINEERING** after recommendation by the external examiner was defended by the candidate before the following members of the examination committee. The performance of the candidate in the oral examination was satisfactory. We, therefore, forward with recommendation.

(M. S. Dulawat)

Minor Guide and
Assistant Professor
Dept. of Renewable Energy Engg.
College of Agril. Engg. & Tech.
J.A.U., Junagadh

(T. D. Mehta)

Major Guide and
Associate Professor,
Dept. of Farm Mach. and power Engg
College of Agril. Engg. & Tech.
J.A.U., Junagadh

(V. K. Tiwari)

Professor and Head
Dept. of Farm Mach. and Power Engg.
College of Agril. Engg. & Tech.
J.A.U., Junagadh

(N. K. Gontia)

Principal and Dean
College of Agril. Engg. & Tech.
J.A.U. Junagadh

Approved By

(D. R. Mehta)

Director of Research and Dean, P.G. Studies
Junagadh Agricultural University
Junagadh

ACKNOWLEDGEMENTS

*It is my proud privilege to express my sincere gratitude and indebtedness to my major Guide **Dr. T. D. Mehta**, Associate professor, Department of Farm Machinery and Power Engineering, College of Agricultural Engineering and Technology, Junagadh Agricultural University, Junagadh for his thoughtful guidance, versatile advices, constant co-operation, encouragement for completing my research work, constant efforts, inspiration towards completion of this project and meticulous advices throughout the course of present study, which inspired me to carry out the research work in time.*

*I express my deep sense of gratitude to **Dr. N. K. Gontia**, Hon'ble Vice Chancellor, **Dr. D. R. Mehta**, Registrar, Dean P. G. Studies and Director of Research, Junagadh Agricultural University, Junagadh and **Dr. N. K. Gontia**, Principal and Dean, College of Agricultural Engineering and Technology, Junagadh Agricultural University, Junagadh for providing necessary facilities during the course of the study.*

*It is my privilege to offer sincere and well devoted thanks to **Dr. K. B. Jhala**, Associate Professor & Head, Department of Farm Machinery and Power Engineering. **Dr. V. K. Tiwari**, Head, R. T. T. C., JAU, Junagadh. I express my heartfelt thanks to Dr. M. S. Dulawat (Minor Guide) Assistant Professor, Dept. of Renewable Energy Engineering , **Prof. A. L. Vadher**, Assistant Professor, Dept. of Farm Machinery & Power Engineering, and Dr. R. K. Kathiriya, Associate Research Scientist Office of the Directorate of Research JAU, Junagadh as the member of Advisory committee for their constant encouragement and kind help in providing necessary facilities in time made the research study an achievement.*

*It is my privilege to offer sincere thanks to **Dr. R. Yadav**, Professor and Head, Department of Farm Engineering, **Prof. P. P. Gajjar**, Assistant Professor, **Mr. Hiren Sekhada**, Lab Technician, Er. Chirag Jadav, Er. Ravi Katheria, Mr. P. D. Devmurari, Er. J. M. Modhvadiya, Er. R. D. Bandhiya, Er. Kiran Narola, Mr. Imranand, Mr. Sadikbhai, Mr. Nikunjbhai, Mr. Maheshbhai, Mr. Jamanbhai, Driver and all staff members of Dept. of Farm Machinery & Power Engineering., CAET, JAU, Junagadh*

for their help and support which inspired to do this work in the field of Farm Machinery and Power Engineering.

*I express my heartiest thanks to **Dr. R. M. Solanki**, Farm Manager, Department of Agronomy, COA, JAU, Junagadh, and S. P. Ozha maam, for allowing me to carry out the field experiments in Mechanized Commercial Farm, College of Agriculture, JAU, Junagadh and for kind support throughout the experiment.*

There is no limit to express a specified thanks to sweet & lovely friends Abhishek Pandey, Shubham Gaikwad, Rohan Sahu, Anisha Pradhan, Namrata Sankhla, junior Pradeep patidar, Kaivalya and all my junior & senior colleagues for their timely help and kind cooperation during the course of my study and research work. It may not be possible to mention name of all my friends. I am sincerely thankful to those who helped me directly and indirectly.

*I gratefully acknowledge the '**Indian Council of Agricultural Research, Education Division**' for providing this opportunity to pursue my master's degree from Junagadh Agricultural University and its financial support in the form of '**National Talent Scholarship**' throughout my study period.*

*Diction is not enough to express my gratitude to my family members especially my parents **Mr.Ramsingh Choudhary** and **Mrs.Urmila Choudhary** and my sister **Vijeta Choudhary** and my brother **Rameswar pratap singh** whose selfless love, affection, constant encouragement, sacrifices, sincere prayers and blessings have always been vital source of inspiration in my life.*

Finally, I thank God for bestowing me with divine spirit, essential strength and necessary support to find my way towards a glorious career amidst several hurdles and struggles.

Place: Junagadh

Date: 29/07/2022

(JAGRITI CHOUDHARY)

CONTENTS

CHAPTER NO.	TITLE	PAGE NO.
I	INTRODUCTION	1-10
	1.1 General	1
	1.2 Types of weed	4
	1.3 Weeding operation	4
	1.3.1 Chemical method	5
	1.3.2 Cultural method	6
	1.3.3 Mechanical method	7
	1.3.4 Biological method	9
	1.4 Practical utility of the research problem	9
	1.5 Objective	10
II	REVIEW OF LITERATURE	11-22
	2.1 Weeds	11
	2.2 Losses due to weeds	12
	2.3 Machine factor	13
	2.3.1 Handle height of weeder	14
	2.3.2 Angle of handle	15
	2.3.3 Blade width and angle	15
	2.4 Drudgery in weeding	16
	2.5 Push/Pull strength of agricultural workers	17
	2.6 Ergonomics aspects	18
	2.7 Anthropometry	21
	2.8 Review summary	21
III	MATERIALS AND METHODS	23-46
	3.1 Theoretical considerations	23
	3.2 Design consideration	23
	3.2.1 Crop parameters	23
	3.2.1.1 Type of crop	24
	3.2.1.2 Row and plant spacing	24
	3.2.1.3 Crop canopy	25

CHAPTER NO.	TITLE	PAGE NO.
	3.2.1.4 Crop height	25
	3.2.2 Functional parameters	26
3.3	Design of main components	26
	3.3.1 Handle	26
	3.3.2 Frame	28
	3.3.3 Finger disc	29
	3.3.4 Tynes	32
	3.3.5 Ground wheels	33
	3.3.6 Different views of developed finger weeder	34
3.4	Material of constructions	35
3.5	Experimental procedure	35
	3.5.1 Moisture content of the soil	35
	3.5.2 Bulk density of soil	36
	3.5.3 Depth and width of cut	37
	3.5.4 Draft requirement	37
	3.5.5 Operating speed	38
	3.5.6 Time loss	38
	3.5.7 Plant damage	38
	3.5.8 Weeding efficiency	39
3.6	Determination of Power requirement and efficiency	40
3.7	Ergonomic evaluation	41
	3.7.1 Physiological evaluation	41
	3.7.2 Anthropometry data	43
3.8	Economical consideration	44
	3.8.1 Manual weeding	44
	3.8.2 Mechanical weeding	44
	3.8.2.1 Cost of operation	44
	3.8.2.1.1 Fixed cost	45
	3.8.2.1.2 Operation cost	46
	3.8.2.1.3 Total cost of weeding per hour	46

CHAPTER NO.	TITLE	PAGE NO.
	3.8.3 Economical comparison of mechanical weeding with manual weeding	46
IV	RESULTS AND DISCUSSION	47-71
4.1	Design consideration	47
4.1.1	Crop parameters	47
4.1.1.1	Type of crop	47
4.1.1.2	Row and plant spacing	47
4.1.1.3	Crop canopy and crop height	48
4.1.2	Functional parameters	48
4.2	Design of main components	48
4.2.1	Specification of developed finger weeder	48
4.3	Performance evaluation of developed finger weeder	50
4.3.1	Pre-test observations	51
4.3.1.1	Moisture content of the soil	51
4.3.1.2	Bulk density	51
4.3.2	Field observations	51
4.3.2.1	Depth and width of cut	51
4.3.2.2	Draft of implement	51
4.3.2.3	Operating speed	53
4.3.2.4	Time loss in turning and adjustment	54
4.3.2.5	Plant damage	55
4.3.2.6	Weeding efficiency	55
4.4	Power requirement and efficiency	56
4.5	Ergonomic evaluation	62
4.5.1	Physiological evaluation	62
4.5.2	Anthropometry data	66
4.6	Economical consideration	66
4.6.1	Manual weeding	66
4.6.2	Mechanical weeding	66
4.6.2.1	Cost of operation	66
4.6.3	Economical comparison of mechanical weeding with manual weeding	68

CHAPTER NO.	TITLE	PAGE NO.
V	SUMMARY AND CONCLUSION	72-73
	5.1 Summary	72
	BIBLIOGRAPHY	74-79
	APPENDICES	80-93

LIST OF TABLES

Table No.	TITLE	Page No.
1.1	Different types of weeds	5
1.2	Yield losses due to weeds in some important crops	8
2.1	Subject height vs. handle height from ground at a point of minimum force	14
3.1	Dimensions of handle	27
3.2	Dimensions of frame	28
3.3	Dimensions of finger disc	30
3.4	Dimensions of tynes	32
3.5	Dimensions of ground wheels	33
3.6	Classification of manual jobs based on the physiological response for India male workers	42
3.7	Basic body dimensions of weeder operators	43
4.1	Row and plant spacing of selected crops	47
4.2	Canopy and height of selected crops	48
4.3	Detailed specifications of the developed finger weeder	49
4.4	Depth and width of cut of developed finger weeder	51
4.5	Mean value of draft requirement of different operators	52
4.6	Operating speed during weeding on blackgram and groundnut field	53
4.7	Mean values of the speed in relation to the operators in groundnut field and blackgram	54
4.8	Shows the plant damage percent on groundnut and black gram field	55
4.9	Mean value of weeding efficiency on groundnut and blackgram field	55
4.10	Mean value of power calculated with respect to groundnut and blackgram field	57
4.11	Mean value of theoretical field capacity on groundnut and blackgram field.	58

Table No.	TITLE	Page No.
4.12	Mean value of effective field capacity on groundnut and black gram field	60
4.13	Mean value of field efficiency on groundnut and blackgram field	61
4.14	Mean value of heart rate after work on groundnut and blackgram field	62
4.15	Mean value of oxygen consumption rate on groundnut and blackgram field	64
4.16	Mean value of energy expenditure rate on groundnut and blackgram field	65
4.17	Mean value of calculated cost of operation on groundnut and blackgram field	67
4.18	Value of operational time of finger weeder and hand weeding	68
4.19	Values of cost of operation of finger weeder and hand weeding	70
4.20	Values of cost of operation of finger weeder and hand weeding	71

LIST OF FIGURES

Fig. No.	TITLE	Page No.
3.1	Experimental field of Groundnut and Black gram crop	24
3.2	Measurement of row to row spacing	24
3.3	Measurement of crop canopy	25
3.4	Measurement of crop height	25
3.5	Views of handle of developed finger weeder	27
3.6	Different views of frame	28
3.7	Different views of frame of developed finger weeder	29
3.8	(a) finger disc, (b) Flat finger disc,	30
3.9	(c) Shaft and (d) Bushing	31
3.10	View of finger disc attachment	31
3.11	Views of tynes of developed finger weeder	32
3.12	Views of ground wheels of developed finger weeder	33
3.13	Isometric view of developed finger weeder	34
3.14	Top view of developed finger weeder	34
3.15	Front view of developed finger weeder	34
3.16	Side view of developed finger weeder	35
3.17	Measurement of soil moisture content	36
3.18	Measurement of bulk density of soil	36
3.19	Measurement of depth of cut using depth gauge	37
3.20	View of spring type load indicator	38
3.21	Weed counting before and after weeding on Black gram field	39
3.22	Weed counting before and after weeding on Groundnut field	40
3.23	Measurement of anthropometric	44
4.1	Effect of different operators on draft	52
4.2	Effect of different operators on speed on groundnut and blackgram field	54

Fig. No.	TITLE	Page No.
4.3	Effect of different operators on weeding efficiency in groundnut and blackgram field	56
4.4	Effect of operators on power requirement in groundnut and blackgram field	57
4.5	Effect of operators on theoretical field capacity in groundnut and blackgram field	59
4.6	Effect of operators on effective field capacity in groundnut and blackgram field	60
4.7	Effect of operators on field efficiency in groundnut and blackgram field	61
4.8	Effect of different operators on heart rate in groundnut and blackgram field	63
4.9	Effect of different operators on oxygen consumption rate in groundnut and blackgram field	64
4.10	Effect of different operators on energy expenditure rate in groundnut and blackgram field	65
4.11	Effect of different operators on cost of operation in groundnut and blackgram field	67
4.12	Values of operational time of finger weeder and hand weeding	69
4.13	Values of energy consumption of finger weeder and hand weeding	70
4.14	Values of cost of operation of finger weeder and hand weeding	71

LIST OF ABBREVIATIONS

Agril.	:	Agricultural
Anon.	:	Anonymous
Avg.	:	Average
B. Tech.	:	Bachelor of Technology
BMI	:	Body mass index
CAET	:	College of Agricultural Engineering and Technology
Ch.	:	Chapter
Cm	:	Centimeter
Cm ³	:	Cubic centimeter
COA	:	College of Agriculture
Dept.	:	Department
Dr.	:	Doctor
dia.	:	Diameter
EFC	:	Effective field capacity
Engg.	:	Engineering
etc	:	And so on
<i>et al.</i>	:	And others
Fig.	:	Figure
FMPE	:	Farm Machinery and Power Engineering
gm	:	Gram
GI	:	Galvanized Iron
h	:	Hour
ha	:	Hectare
ha/h	:	Hectare per hour
<i>i.e.</i>	:	that is
ICAR	:	Indian Council of Agricultural Research
IS	:	Indian Standard
JAU	:	Junagadh Agricultural University

kJ/min	:	Kilojoule per minute
kgf	:	Kilogram force
kg/hr	:	Kilogram per hour
kg/ha	:	Kilogram per hectare
km	:	Kilometre
km/h	:	Kilometre per hour
m	:	Meter
MC	:	Moisture content
MJ/ha	:	Megajoule per hectare
mm	:	Millimeter
MS	:	Mild Steel
M. Tech.	:	Master of Technology
m/s	:	Meter per second
No.	:	Number
pp.	:	Page number
Reg. No.	:	Registration number
REE	:	Renewable Energy Engineering
s	:	Second
S	:	Speed of operation
S. No.	:	Serial number
Sr. No.	:	Serial number
Tech.	:	Technology
TFC	:	Theoretical Field Capacity
yr.	:	Year (s)
°	:	Degree
%	:	Per Cent
₹	:	Rupees
₹/h	:	Rupees per hour
₹/ha	:	Rupees per hectare
θ	:	Angle of inclination

LIST OF APPENDICES

Appendix No.	TITLE	Page No.
A	Calculation of soil moisture content	80
B	Calculation of bulk density	82
C	Cost calculations	84
D	Cost of hand weeding	87
E	Calculation of body mass index	88
F	Calculation of operational time	89
G	Calculation of energy consumption	91
H	Calculation of weed control efficiency	93

CHAPTER - I

INTRODUCTION

1.1 GENERAL

Despite accounting for only 2.4 percent of the world's geographical area and 4% of its water resources, India is responsible for 17 percent of the world's human population and 15% of the world's livestock. Agriculture has always been the backbone of the Indian economy, and despite decades of concerted industrialization, agriculture remains a source of pride. (Singh *et. al.*, 2014)

Agriculture and allied sector contribute nearly 17.76 % of GDP of India, while employs more than 54.77% of the total work force in India. Agriculture in India is currently growing at an average compound annual growth rate (CAGR) of 3.4%. According to the Economic Survey of India (2021) stated that the total food production in the nation recorded at 296.65 million tonnes in the financial year and it has been increased by 11.44 million tonnes in the financial year 2019 (Anon., 2020).

The mechanization raises agricultural productivity, increase profitability and also improves quality of life of farming community. There are several constraints in agriculture like climate change, insect and pests but weeds are one of the major reasons for declined yield per unit agricultural area in India.

Agriculture is the backbone of India and weed removal is one of the primary processes in the field. It is a necessity for weeds to be removed in all the fields to increase the quality of crops and to decrease the effect of weeds on crops. A weed may be defined as any plant or vegetation that interferes with the objectives of farming or forestry, such as growing crops, grazing animals or cultivating forest plantations. A weed may also be defined as any plant growing where it is not wanted. For example, a plant may be valuable or useful in a garden or on a farm or plantation but if the same plant is growing where it reduces the value of agricultural produce or spoils aesthetic or environmental values, then it is considered a weed. At present, weed control is one of the major problems faced by the farmers while growing crops, especially it is more acute during the kharif season. Heavy rain during the kharif season provides favorable conditions for the growth of weeds. It is essential to remove the weeds at a low cost to obtain higher yields

Weeding is one of the most important intercultural operations during the growth period of every crop such as wheat, maize, pulses, vegetable crops etc. The concept of weed is the unwanted plant in the main crop, which competes with the main crop for nutrients required for plant growth in the field. It can also be said that weed is the plant out of place, unwanted, even poisonous that interferes with agricultural operations, increase labour, adds to cost and reduces yield. Weeds within a row are poorly accessible and in the case of a late weed infestation, it can seriously disrupt the development of the crop and cause costly manual labour. When there is no effective weed control measure that may lead to significant yield reduction. Weeding is an important and necessary intercultural operation in a crop production system. In the same way, it is labour intensive agricultural operation. In terms of labour requirement, weeding takes up to 25 % of the labour requirement during a cultivation season (Yadav and Pund, 2007). Major investment in crop production goes toward weed control in the case of major crops. About 4.2 billion rupees were spent every year for controlling weeds in the country. Because of weeds alone, around 40 million tons of major food grains were lost every year (Dixit and Syed, 2008). Weeding and hoeing are generally done 15 to 20 days after sowing. The weed should be controlled and eliminated at an early stage. Depending upon the weed density, 20 to 30 % loss in grain yield is quite usual which might increase up to 80 % if adequate crop management practice is not observed (Konda and Rao, 2017). The most common method of weed control is mechanical, chemical, biological and cultural methods. Chemical control involves the use of herbicides.

The khurpi is the most versatile hand hoe for the removal of weeds but it takes 300-700 man-hours to cover 1 hectare depending upon weed infestation and crop density. The use of long handle wheel hoe type weeders, reduce this weeding time to 100-125 man-hour (Dighe, 2003). As a result, the traditional tool like khurpi, manually uprooting of weeds is still followed by a majority of farmers for weed control. It is a slow process resulting in delayed weeding, high cost of operation and hazard. Manual weeding can give a hygienic weeding but it is a strenuous process, it can give a clean weeding but it is a slow process and very costly (Biswas, 1990). Hand weeding requires more energy and more time which may ultimately lead to a higher cost of weeding. For hand weeding the normal man-hour requirement as per estimate is around 400-600 per which amounts to Rs 2200 per hectare. This estimate

depends upon weed infestation. The other major issue in hand weeding is the availability of labour (Vivek *et al.*, 2013).

Herbicides control weeds either by stopping or altering the plant's regular growth pattern by drying out the leaves or stems or by making it drop its leaves. Chemical weeding is one of the most widely used methods for weed removal. But these chemicals used for weeding are not safe for living organisms and toxic in nature. Due to these unfavorable effects on the environment, farmers prefer mechanical weeding.

The mechanical weeding operations results in a better quality of work, higher yield and ease in operation than traditional methods. Mechanical weed control not only uproots the weeds between the crop rows but also keeps the soil surface loose, ensuring better soil aeration and water intake capacity. Out of these four methods, mechanical weeding either by hand tools or weeders are most effective in both dry and wetland (Gite and Yadav, 1990).

Finger weeder is a cultivation tool that uses ground driven, star-shaped discs to disturb the soil very close to the cultivated crop. Their main advantage is their ability to reach in-row weeds. They do not damage the cultivated crop because of finger disc. They are best for transplanted or well-established crops. The finger weeder is the only mechanical hoe that also controls weeds between the row and within the row, thanks to a slanted position and adjustable overlap of the finger plates and it greatly reduces manual labour. It offers good performance for most row crops. Finger weeders work both in inter-row and intra-row crop lines to control weeds. Intra row weeding is attained by finger weeders containing two pairs of wheels furnished with fingers thrilling the soil surface. Two attached wheels come across the crop row, during the procedure small weeds get pulled out. Depth differs from 10-30 mm. The finger weeder consists of two wheels with fingers rotating on either side of the crop row. There are metal drive pins underneath the flexible finger disc. The drive-pins engage to the ground and work at ground speed. Because the drive pins are of a smaller diameter than the flexible fingers, the fingers rotate faster than ground speed. Though developed as a single row tool by the budding company in Michigan, the USA in the mid-twentieth century, in the late 1990s finger weeders were redesigned in Europe by the Kress Company and the Steketee Company. Their simpler design allows finger weeders to be spaced closer together and set up on cultivator frames in

gangs, like shovels, hilling disc, and other cultivating implements. Finger weeders are generally more successful in transplanted crops because of the bigger size difference between crops and weeds. It was observed that the finger weeder killed up to 95 % of weeds. Like most weeding tools, the efficacy of the finger weeder is greatly reduced when used in soil that has a crusted surface (Bleeker *et al.*, 2002).

Ergonomics deals with human behaviour, capabilities, limitations and other characteristics to the design of tools, machines, systems, for effective human use (Chapanis, 1985). The major hindrance for the adoption of the implements or tools may be the physiological and muscular fatigue they induce in the beginning. The performance of any instrument especially manually operated ones could be considerably improved if ergonomic aspects are given due consideration (Gite, 1993).

In India farmers mainly follow hand weeding through mechanical weeding is slowly becoming popular, despite it being costly. The use of herbicides will have a residual effect and change the quality of the soil. An estimate of 400 to 600 man-hour requirement of hand weeding amounts to Rs.2200 per hectare, which also depends upon weed infestation. Hand weeding is overwhelming and hurts workers who are mostly women. Depending on weed density and species in the field, labour requirements for weeding varied to between 10 to 15 persons per hectare in fields. Availability of labour is also scarce. Moreover, the labour requirement for weeding depends on weed flora, weed intensity, time of weeding and soil moisture at the time of weeding and the efficiency of the worker. Often several weeding operations are necessary to keep the crop weed-free. Reduction in yield due to weed alone was estimated to be 16 to 42 % depending on crop and location which involves one-third of the cost of cultivation (Konda and Rao, 2017).

1.2 TYPES OF WEEDS

The common types of weeds which are found in Saurashtra are shown in Table 1.1.

1.3 WEEDING OPERATION

Weeding is the process of remove unwanted plants so that the regular crop can be grown profitably. The quantitative and qualitative production of crop depends upon the effectiveness and timeliness of weeding operation. Weeds cause 45 % of annual yield loss as compared to the disease 20 %, insect 30 % and pest 5 %. Variant losses

due to weeds are given as annual monetary loss of Rs. 19800 millions (Mukhopadhyay, 1992), in major crops Rs. 4200 million (Natarajan, 1987) and in food grain 60 million tonnes (Biswas, 1984).

Table 1.1 Different types of weed (Teronpi, 2017)

Local name	English name	Scientific name
Sedges weeds		
Chidho	Purple nutsedges	<i>Cyperus rotundus</i> L.
Monocot weeds		
Dharo	Bermuda grass	<i>Cynadon dactylon</i> (L.) Pers
Kariyu	Single grass	<i>Brachiaria</i> spp.
Samo	Samo grass	<i>Echinochoa colonum</i> (L.) Beauv.
Dicot weeds		
Kanjero	Kundra	<i>Digera arvensis</i> Forsk
Bhoi-amli	Hazardana	<i>Phyllanthus niruri</i> (L.)
Shesmul	Dayflower	<i>Commelina benghalensis</i> L.
Popti	Sun berry	<i>Physalis minima</i>
Luni	Purslane	<i>Portulaca oleracae</i> L.
Akandandi	Tridesc	<i>Tridesc procumbens</i> L.
Venkariyo	Wild indigo	<i>Indigofera glandulosa</i>
Dudheli	Garden spurge	<i>Euphorbia hirta</i>
Cogress grass	Carrot grass	<i>Parthenium hysterophorus</i>
Chandanbel	Conolvulus arvensis	<i>Field bind</i>

1.3.1 Chemical Method

Chemical weed control is essentially a technology of the twentieth century. Prior to 1900, no one seriously considered the possibility of using pesticides to selectively eliminate weeds from crops. Weeds were too physiologically connected to crop plants and yet too diverse to believe that they could be chemically eliminated without harming or killing useful plants. Commercial operations require chemical weed management, and herbicides are administered both before and after the crop emerges. Because most herbicides are tailored to specific soil types and weed

populations, no one chemical can be used globally. Herbicides are chemical compounds that are used to control weeds.

1.3.2 Cultural Method

Tillage, planting, fertiliser application, irrigation, and other cultural practices are used to create a favourable environment for the crop. These methods, when used correctly, aid in weed control. Although cultural methods alone cannot control weeds, they can help to reduce their population. As a result, they should be used in conjunction with other approaches. Tillage, fertilizer application, and irrigation are all important aspects of cultural methods. Aspects such as variety selection, sowing time, cropping system, farm cleanliness, and so on can also help control weeds.

Summer tillage, also known as off-season tillage, is an effective cultural method for controlling perennial weed populations in crop cultivation. Clod formation should be encouraged by pre-cropping tillage. These clods, which contain weed propagules, dehydrate as they dry. Following tillage operations, the clods should be broken up into small units to expose the shrivelled weeds to the hot sun even more.

Drip tape is buried in the subsurface near the planting bed in a buried drip irrigation system. This prevents weeds from getting water while still allowing moisture to reach the crops. This is most effective when the weather is dry. Due to a lack of adequate plant population, heavy weed infestation occurs, which is difficult to control later. To obtain a proper and uniform crop stand capable of competing with weeds, practices such as seed selection, proper sowing method, adequate seed rate, seed protection from soil borne pests and diseases, and so on are critical.

There is also a method for using solar energy to desiccate weeds. By covering a pre-soaked fallow field with a thin transparent plastic sheet, the soil temperature is raised by 5 – 10°C. The plastic sheet blocks long-wave back radiation from the soil, preventing energy loss and preventing moisture evaporation.

Intercropping suppresses weeds more effectively than sole cropping and thus allows for the use of crops as weed management tools. Green gramme and soybean are two short-duration pulses that effectively smother weeds without reducing the main crop yield. Cropping crops that choke out weeds, such as hemp, *Mucuna*

pruriens, and other crops, can be a very effective method of weed control in crop rotation. It's a way to avoid herbicides while still reaping the benefits of crop rotation.

This method has the following disadvantages:

1. Immediate and quick weed control is not possible
2. Weeds are kept suppressed
3. Perennial and problematic weeds cannot be controlled
4. Adoption is difficult

1.3.3 Mechanical Method

Weeding or interculturing can be accomplished using mechanical, manual, animal, or power-driven tools. The mechanical method of weed control is the most effective of all the methods. The mechanical method is said to keep the soil surface loose, allowing for better aeration and moisture conservation.

Manual weeding is precise, but it takes 900-1200 man-hours per hectare of land. Weeding operations cannot be completed in a short period of time due to a severe labour shortage during peak seasons (Nag and Dutta, 1979). Furthermore, the operation is inconvenient, causing drudgery due to the operator's awkward working posture. Back pain can cause musculoskeletal problems (Rainbird and Neil, 1995). It also depends on the weed infestation. Another major concern is the availability of labour.

In Indian agriculture, animal power is also important for mechanical weed control. Because of their simplicity of construction and lower cost, traditional animal-drawn weeders made by village artisans are widely used (Biswas *et al.*, 2000). During monsoons, shallow tillage and weeding operations are repeated in black soils with an animal drawn straight blade harrow to remove weeds. The cost of maintaining a pair of bullocks has increased in recent years. As a result, the use of animals in agriculture is decreasing.

Tractors are also used for inter-culturing and other light operations in the standing crop, such as spraying and dusting. Due to their higher weight and large turning radius, they are frequently unsuitable for such operations, compacting the soil and damaging the standing crops.

Weed control has been used mechanically or physically since man began to cultivate crops. Tillage, hoeing, hand weeding, digging, cheeling, sickling, mowing, flooding, and mulching are examples of mechanical methods.

Weeds are killed by tillage because they are removed from the soil. Plants may be weakened as a result of root and stem pruning injuries, lowering their competitiveness and regenerative capacity. Weeds are also buried by tillage. Ploughing, discing, harrowing, and levelling are examples of tillage operations that promote weed germination by increasing soil turnover and exposing seeds to sunlight, which can then be effectively destroyed later. Tillage damages and destroys both the top and underground growth of perennials.

For centuries, the hoe has been the most appropriate and widely used weeding tool. However, it is still a very useful tool for getting results quickly and cheaply. In row crops, it is used to supplement the cultivator. Hoeing is especially effective on annuals and biennials because weed growth is reduced. It killed the top growth of perennials but had little effect on the underground plant parts, resulting in re-growth.

This method has the following disadvantages:

1. Time-consuming
2. Possibility of crop damage
3. Requires ideal and optimum specific conditions

Anonymous (2017) stated that weed-related losses are classified as follows:

Table 1.2 Yield losses due to weeds in some important crops

Crop	Yield loss range (%)	Crop	Yield loss range (%)
Rice	9.1-51.4	Sugarcane	14.1-71.7
Wheat	6.3-34.8	Linseed	30.9-39.1
Maize	29.5-74.0	Cotton	20.7-61.0
Millets	6.2-81.9	Carrot	70.2-78.0
Groundnut	29.7-32.9	Peas	25.3-35.5

1.3.4 Biological Method

The method entails the use of natural enemies to control certain weeds. The goal is to reduce the soil population below the level of economic injury (Anderson, 1977), i.e. the non-injurious to man's interest level. This can be accomplished by biotic agents acting directly or indirectly.

1.4 PRACTICAL UTILITY OF THE RESEARCH PROBLEM

Weed removal is one of the major activities in agriculture. The chemical method of weed control is more prominent than manual and mechanical methods. Environmental degradation and pollution caused by chemicals are reduced by the use of mechanical weeders. However, its adverse effects on the environment are making farmers consider and accept mechanical methods of weed control. Chemical weeding is the most extensively used method of weed removal but these chemicals used for weeding are harmful to living organisms and toxic in nature. Research has been carried out to use some combination of various methods of weeding. The need to replace the use of herbicides with more sustainable weed control techniques encourages the definition of innovative physical weed control strategies. Mechanical and thermal means were used to control and remove weeds, which is one of the methods frequently used to remove weeds from agricultural fields.

Weeding with the use of tools like cutlass and hoe requires a high labour force in farming hence mechanical weeder is necessary to reduce the labour force. The low effective operation, low work effort and more time requirement for different types of hoe and cutlass can be overcome with the use of a mechanical weeder.

The conventional method of weeding takes more time. Generally assuming squatting and bending posture while performing the activity and maintaining the same posture for long hours may contribute towards developing musculoskeletal disorders. On the other side, manual weeding requires a massive labour force which is usually 900 to 1200 man-hour/hectares (Konda and Rao, 2017). The cost involved in weeding operation may account for about 25 % of the total labour cost (Yadav and Pund, 2007). In a country like India, weeding operation is mostly carried out manually with cutlass or hoe that call for high labour input. It is a very tedious and time-consuming process.

As the time available for weeding is limited, a developed finger weeder will be used to complete the weeding operation in due time at less cost. Therefore, effort will be made to develop a finger weeder for dry land crops, to evaluate its field performance along with the ergonomic aspects. Mechanical weeding maintains crop yields and reduces the cost of weed control. Mechanical weeding aerates the soil, stimulates crop growth, reduces pollution and breaks soil crust.

1.5 OBJECTIVES

1. To develop a manually operated finger weeder
2. To evaluate the performance of developed finger weeder.
3. To evaluate the ergonomic parameters of developed finger weeder.
4. To assess the economics of developed finger weeder

CHAPTER – II

REVIEW OF LITERATURE

A detailed review of literature is essential for any research endeavor. The purpose of the review of literature is to gain insight into the research conducted in the related field and understand the concepts, trends and identify appropriate research design, methods of measuring variables and techniques of analysis. The important and related information has been categorized under the following headings:

- 2.1 Weeds
- 2.2 Losses due to Weeds
- 2.3 Machine Factor
- 2.4 Drudgery in Weeding
- 2.5 Push-pull Strength of Agricultural Workers
- 2.6 Ergonomic Aspects
- 2.7 Anthropometry

2.1 WEEDS

Bogdan *et al.* (2006) developed an ideal network for weed management in maize fields under the soil-climatic conditions of Cluj-Napoca, Romania, from 2003 to 2005. Due to weed seed stock in the arable layer and meteorological circumstances that allowed weeds to grow alternately, as well as the establishment of issue species during the maize vegetative phase, when no tillage was undertaken, weed encroachment of maize crops has grown in the Cluj area. The combination of an acetochlore-based herbicide and a maize herbicide has good efficiency and durability in controlling the full weed spectrum from maize crops. The combination of the RELAY 90EC 2.2 l/ha pre-emergence florasulam-based herbicide and acid 2.4D: MUSTANG 0.6 l/ha post-emergence herbicide exhibited a control degree of 72 percent for the entire vegetative season. Variants treated with DUAL GOLD 960EC 1.5 l/ha before emergence had the highest average control degree. The complex herbicides OLTISAN M. 1 l/ha or RING 80 WG 25g/ha were employed on vegetation, with an average control degree of 73 percent and 75 percent, respectively.

Naidu (2012) suggested that weed identification could be the first step toward balancing the demand for weed management with the need for biodiversity and more

appropriate production practices. Knowing how to recognize weeds is crucial since it aids in evaluating the expected amount of difficulties, as weeds differ in their ability to reduce productivity and quality, as well as their ability to be useful. The Directorate of Weed Research (DWR) in Jabalpur has created a Weed Atlas for key weeds in important crops in 435 districts throughout 19 states, as well as a weed identification guide.

Rao and Chauhan (2015) reported that in India, the widely diverse agriculture and farming systems are plagued by several forms of weed problems. Weeds reduce crop yields by 10 to 80 percent, as well as lowering product quality and posing a health and environmental risk. Agriculture, forestry, and the aquatic environment are all hampered by invasive alien weeds. Weed control in India has always relied heavily on human weeding. However, rising labour prices and scarcity are prompting farmers to use labor-saving methods. Herbicides are one of them, with a 15 percent yearly growth rate. Indian farmers utilise integrated weed management (IWM), with variable degrees of acceptance from one farm to the next. IWM is promoted in crop production systems, as well as aquatic and forest environments, and encompasses preventative, mechanical, cultural, chemical, and biological techniques. Understanding weed ecology and biology, as well as the use of information technology, should all be part of developing and disseminating effective, cost-effective, and environmentally friendly IWM methods in India.

2.2 LOSSES DUE TO WEEDS

Malavia *et al.* (1998) indicated that weed was the main cause of yield loss in Gujarat. Aside from that, weeds deplete a significant quantity of plant nutrients and degrade soil quality.

Milberg and Hallgren (2004) undertook field trials testing pesticides in Sweden to investigate a large-scale pattern in cereal yield loss owing to weeds. They weighed the relative importance of variations in areas, crops, soils, and years. Weed biomass explained 31% of the variation in yield loss owing to weeds in a negative hyperbolic function. Spring-barley, spring-wheat, oats, winter-winter, and rye were the crops that were most and least damaged by weeds. Due to spatial heterogeneity of weeds, pests, and soil among trials, clay soil incurred the fewest yield losses while organogenic soil suffered the biggest yield losses when adjusted for weed abundance.

a) Reduction in crop yield

Weeds fight for nutrients, soil moisture, space, and sunlight with agricultural plants. In general, a one kilogram increase in weed growth equals a one kilogram decrease in crop growth.

b) Loss in crop quality

A crop that contains weed seeds should be discarded, especially if it is being raised for seed.

c) Weeds as reservoirs of pests and disease

Weeds are a type of organism that live in a community. As a result, they provide food for some animals and are vulnerable to a variety of pests and diseases.

d) Interference in crop handling

Weeds can make agricultural machinery operating more difficult, costly, and even impossible.

e) Reduction in land value

A heavy infestation of perennial weeds could render the land unfit for cultivation, resulting in a loss of monetary value. Due to heavy infestations of nutgrass (*Cyperus rotundus*) and other perennial grasses, thousands of hectares of cultivable land in rice-growing regions of India have been abandoned or are not being routinely farmed.

f) Loss of human efficiency

Weeds reduce human efficiency through physical discomfort caused by allergies and poisoning.

g) Limitation of crop choice

When certain weeds are heavily infested, it will limit the growth of a particular crop.

2.3 MACHINE FACTOR

Some study was conducted about different parts of weeder by different scientists have analyzed and reviewed below.

2.3.1 Handle Height of Weeder

Gite and Yadav (1990) performed an experiment of simulating weeder operation with healthy adult men in the laboratory. They suggested that for minimum physiological cost and muscular fatigue, the handle height of the weeder should be within 0.7 to 0.8 times of shoulder height. Considering this range and available anthropometric data, handle height should be 100 cm for Indian workers.

De Looze *et al.* (2000) found that the magnitudes and directions of forces did not differ between the cart and the bar pushing and pulling. Force direction was affected by the horizontal force level and handle height. As handle height and horizontal force level increased, the pushing force direction changed from 45° (SD 3.3°) downward to near horizontal, while the pulling force direction changed from pulling upward by 14° (SD 15.3°) to near horizontal. As a result, it was found that across conditions the changes in force exertion were frequently reflected in changes in shoulder torque and low back torque although of a much smaller magnitude.

Singh (2004) reported that the comfortable angle for a subject to apply the least force is 30°. The effect of subject height on the handle height in relation to the minimum force is given in Table 2.1.

Table 2.1 Subject height vs. handle height from ground at a point of minimum force (Singh, 2004)

Sr. No.	Subject	Subject height (m)	Handle angle with horizontal (degree)	A minimum force applied (N)	Handle height at minimum force (m)
1.	S1	1.76	30°	122.23	1.04
2.	S2	1.74	35°	126.54	1.02
3.	S3	1.66	40°	143.23	0.94

Gite and Yadav (2007) studied an optimum handle height for push-pull type manually operated dry land weeder. He compared four handle heights i.e., 0.6, 0.7, 0.8 and 0.9 of shoulder height (SH) for operating the weeder. Based on physiological

responses, working at 0.7 SH was found to be least strenuous while working at 0.9 SH was found to be most strenuous leading to tiredness in the subjects. Handle height of 0.6 SH proved too low for the subjects resulting in increased fatigue as compared to 0.7 SH and 0.8 SH. Based on the results, 100 cm handle height is recommended for a push-pull type manually operated dry land weeder. The weeding efficiency of wheel hoe was found to be 70 %.

Nkakini and Husseni (2014) developed a push-type manually operated wheel weeder with an adjustable long handle. The hoe performance from the tests on a field of Okra having an inter-row spacing of 800mm, showed that it could remove weed satisfactorily, and eliminate the drudgeries associated with the use of the short handle such as backache, pains at the spine and lower waist region.

2.3.2 Angle of Handle

Yadav *et al.* (2007) stated that the handle at an angle of 37° with horizontal and height of the handle was 955 mm. The height and length can be adjusted as per the need of the operator to suit his posture.

2.3.3 Blade Width and Angle

Biswas *et al.* (1989) studied four basic shapes of weeding tools (straight blade, curved blade, triangular blade and sweep blade) attached with an animal-drawn weeder at the Central Institute of Agricultural Engineering. They optimized the critical dimensions of the tools based on the minimum draft force required per unit working width at laboratory and field conditions as: (i) For straight blades: rake angle ranging from 20.6° to 22.5° , blade width in the range 15-50 mm, blade thickness as small as possible depending upon the mechanical strength and blade angle of 15° or less. (ii) For curved blades: the working width of 200 mm, a radius of curvature was 136.4 mm and rake angle ranged from 22.0° to 22.4° . (iii) For triangular blades: the optimum value of rake angle ranged from 21.6° to 21.9° and the approach angle ranged from 76.9° to 81.6° . (iv) For sweep: approach angle in the range 74.7° to 75.0° , wing width 50 mm or less and blade thickness less than 4 mm. Wing width and blade thickness should be minimal depending on the mechanical strength of the sweep.

Singh (2002) reported that the manual weeders had been classified into five groups, namely small tools, chopping hoes, pull-type weeders, pull-push weeders and push-type weeders. The weeders were provided with different types of blades such as

easy straight blades, v-shape blades, sweep type blades, flattened tines, saw-toothed blades etc. The critical dimensions of the tools were optimized based on the minimum draft force required per unit working width during operation. For straight blades, rake angle, blade width and blade angle ranged from 20.6-22.5°, 15-55 mm and 15° respectively. For curved blades of 200 mm working width optimum values of curvature and rake angle were 136.4 mm and 22-22.4°, respectively. Similarly for triangular blades, optimum values of rake angle and approach angle ranged from 21.6-21.9° and 76.9-81.6°. For sweeps, approach angle, wing width and blade thickness varied from 74.7-75°, 50 mm and less than 4 mm, respectively.

2.4 DRUDGERY IN WEEDING

Sharma *et al.* (2016) studied the performance of twin wheel hoe over the traditional method. The focus of the research was to study the ergonomic parameter on twin wheel hoe to reduce drudgery. According to the study, while using twin wheel hoe as compared to using traditional khurpi, they were comfortable and they worked at a faster rate. Weeding with wheel hoe revealed significantly higher work output than the traditional technology. The percentage increase in output was 86.3 % for twin wheel hoe. It means that the work output was near about twice, as compared to traditional implement. Weeding with traditional tools in strenuous posture caused severe pain in the shoulders, upper back, hands and fingers.

Tripathi *et al.* (2016) studied on reduce drudgery and increasing efficiency in weeding by introducing twin wheel hoe for weeding in crops. The heart rate of workers was recorded while using traditional khurpi and twin wheel hoe to know physiological cost and drudgery assessment of workers. He concluded that the average heart rate was increased by 18.88 % with the use of twin wheel hoe. The drudgery reduction was found to be 70.21 % when a twin wheel hoe was used. The physiological cost of weeding was reduced up to 21.42 % when compared to traditional practice. The twin wheel hoe saved time and increased the efficiency of farm workers. It reduced the labour cost.

Naik *et al.* (2018) studied the field performance of developed manual operated single wheel weeder. Various parameters such as field capacity, weeding efficiency, draft requirement and performance index of weeder were measured during the test. The performance of single wheel weeder was superior in terms of time and cost

required to that of conventional weeding using khurpi. Weeding with a single weeder reduce drudgery, labour and cost requirement.

Swarna *et al.* (2018) studied the three tyne wheel hoe to find out the efficacy of weeder in reducing drudgery among women engaged in weeding activity. Drudgery index, overall body discomfort, workload and musculoskeletal problem were measured while the worker doing the activity. The weeding index and weeding efficiency of the weeder were also measured. The workload during activity was determined based on energy expenditure. Three tyne wheel hoe was found useful in terms of saving time, human effort, increasing work capacity and productivity. It was found to be compatible, easy to handle and applicable in field situations as well as most efficient for weeding vegetable fields. It was also observed that the use of a weeder improved posture and improved the efficiency of the worker. The body discomfort was reduced with the use of a weeder because it involved standing posture eliminating muscular fatigue. The study proved that weeders were ergonomically sound, women-friendly, drudgery reducing and improved workers efficiency.

2.5 PUSH/PULL STRENGTH OF AGRICULTURAL WORKERS

Gite and Yadav (1985) stated that the muscles of the operator provided adequate power to operate the tool for pulling/pushing or swinging action. They also stated that the strength of female workers is approximately 50-67 % of male strength. Males can exert up to 500 N and females about 250 N. This is mainly due to females having smaller grip sizes and muscles.

Guruswami (1997) evaluated three manual weeding tools, peg type weeder, wheel hoe with sweep and wheel hoe with a blade. He concluded that all weeders could be advantageously used by the small and marginal farmers due to their low unit cost of operation, and can easily be pulled or pushed by an average worker.

Agrawal *et al.* (2010) carried out a study to collect data regarding isometric push/pull strength on male as well as female agricultural workers in the state of Madhya Pradesh. The purpose was to test a strength measurement setup developed at the CIAE in Bhopal. Data was collected on 1701 workers from 20 districts in Madhya Pradesh, representing various agro-climatic zones, of which 944 were male and 757 were female. Male subjects had a mean age, stature, and mass of 29.8 ± 9.5 years, 1649 ± 59 mm, and 51.2 ± 6.4 kg, while female subjects had a mean age, stature,

and mass of 33.7 ± 8.2 years, 1519 ± 54 mm, and 45.0 ± 7.3 kg, respectively. Male subjects had greater isometric push pull strength than female subjects. Male workers had isometric push and pull strength of 242.4 ± 56.4 N and 231.0 ± 42.5 N, respectively, in standing posture with both hands (in horizontal plane), while female workers had 175.5 ± 33.9 N and 159.4 ± 42.9 N, respectively. The subjects' mass had a positive relationship with their isometric push-pull strength. Male workers' 5th percentile push and pull strength values were 149.7 N and 161.2 N, respectively, and female workers' 5th percentile push and pull strength values were 119.7 N and 88.8 N, respectively. These values can be used to set design limits for manually operated farm tools and equipment, as well as for manual materials handling activities involving push/pull force based on movement frequency. The design limits of push and pull strengths for male and female workers, respectively, will be 45 and 48 N and 36 and 27 N, based on the ergonomic requirement of 30 percent of the 5th percentile strength for frequent exertions. Push/pull strength limits for occasional exertions can be 60 percent of maximum strength, i.e. 90 and 96 N for male workers and 72 and 54 N for female workers, respectively.

2.6 ERGONOMICS ASPECTS

Rangaswamy *et al.* (1993) and Kamal and Babatunde (1999) reported on manually operated weeder that having a field capacity greater than the traditional hoe, was tested on a small plot of land with crops planted in a row, the machine had a low output of about 0.02 ha/h because of a lot of rigour involved in its use. Farmers also experience a lot of rigour while using short handle hoes such as backaches or strains and spine problems at old age. Improving effectiveness in agricultural mechanization and less drudgery associated with the use of short handle hoe initiated the design of wheeled long handle hoe.

Yadav and Pund (2007) studied the wheeled hoe based on ergonomic factors. The performance of the developed weeder was evaluated upon the groundnut crop. The field capacity of the weeder was found to be 0.048 ha/h. It was observed that the cutting width was proportional to the field capacity. He also reported that the weeding efficiency was 92.5 %. The performance index was found to be 2611.7 it was observed that the developed weeder was not only suitable for groundnut crops but could also be used for other crops by adjusting the row spacing.

Goel *et al.* (2008) studied a manually operated weeder for dry land crops and evaluated its performance. It was compared with other available weeders namely wheel finger weeder, wheel hoe and conventional weeding by using trench hoe for groundnut crop at four levels of soil moisture content of 13.52, 11.63, 9.52, and 8.04 % (db). It was found that the heart rate, oxygen consumption rate and energy consumption rate increase with a decrease in soil moisture content for all the treatments. The highest performance index of 3689.74 was obtained with a developed weeder at 11.63 % moisture content. Lowest plant damage (2.46 to 7.96 %) and lower energy consumption rate (8.34 to 40.05 KJ/min) with highest performance index (678.66 to 3689.74) of developed weeder at different soil moisture content provide its superiority over other weeders.

Verma *et al.* (2013) conducted a study on the ergonomic evaluation of single wheel hoe for reducing the drudgery of the worker. BMI of each subject was measured to know the health status of women. The researchers concluded that the single wheel hoe was found useful in terms of saving time, human effort, increasing work capacity and productivity. The body discomfort of workers with the use of improved wheel hoe weeder eliminated muscular fatigue and excessive loading of intervertebral discs of backbone. The researchers stated that the single wheel hoe weeder was ergonomically sound, women-friendly, drudgery reducing and improved the efficiency of work of women.

Sam and Regeena (2015) studied on development and ergonomic evaluation of long handle weeders for uplands. In this study two long handle, weeders were designed and developed. It was observed that the working heart rate of the operator was found 136 beats/min and 125 beats/min.

Haribabu *et al.* (2015) evaluated ergonomically and mechanical parameters of the wheel hoe. The estimation of Oxygen Consumption Rate (OCR) by measuring the Energy Expenditure Rate (EER) is a fairly accurate and acceptable method. The heart rate of workers varied from 130.33 to 147.52 beats/min and the oxygen consumption rate of workers ranged from 1.389 to 1.738 L/min the weeding efficiency of wheel hoe was observed 75 %.

Mohanty and Mohanty (2015) studied the physical strain of four different types of manual weeders, including the Khurpi, Trench hoe, Wheel hoe, and Wheel

finger weeder, in terms of physiological parameters. During the weeding operation, the physical strain of various male and female agricultural workers was observed. Working heart rate (WHR), oxygen consumption rate (OCR), energy expenditure rate (EER), and relative cost of work load (RCWL) were measured with twelve (12) subjects ranging in age from 18 to 45 years. Mechanical parameters such as actual field capacity (FC) and highest performance index (PI) were measured as well. Selected subjects' physiological and anthropometric measures were also assessed in the lab. With male and female workers, four weeders were evaluated: Khurpi, Trench, Wheel hoe, and Wheel finger. In the instance of khurpi, the working heart rate was found to be as low as 85.6 beats per minute and as high as 130.8 beats per minute. Because these tools are used in a standing position in a push-pull mode, they recorded maximal physiological parameters during weeding activities. The actual field capacity was 0.0311 ha/h in the case of the wheel finger weeder, 0.0149 ha/h in the case of the wheel hoe, and 0.0038 ha/h (38 square metre) in the case of the Khurpi. The shoulder, arm elbow, mid-back, and lower back were found to be the most uncomfortable during wheel hoe and wheel finger weeder use.

Mohanty (2016) conducted an ergonomic study with female workers for various operations in the rice farming system using various farm equipment and machineries. Female agricultural employees doing diverse jobs in the rice cultivation system had their ergonomical characteristics including working heart rate, oxygen consumption rate, energy expenditure rate, and relative cost of work load (percent of VO₂max) evaluated. He concluded that the oxygen consumption was highest for operation of pre germinated paddy seeders (six rows) followed by 4 row paddy transplanters, grain threshing by beating on stone surfaces, water lifting by Tenda, and Bund pruning with shovel. Weeding, Transplanting, Sowing seeds with seeders, and threshing procedures for employees all have greater relative costs of work load. To reduce drudgery and exhaustion, female agricultural workers should be given enough rest breaks.

2.7 ANTHROPOMETRY

Gite *et al.* (2009) conducted anthropometric and strength survey of agricultural workers of India in requirement of Indian agriculture. A total of 75 body dimensions, 4 skin folds and 16 strength parameters were identified for inclusion in the survey considering the requirement of hand tools, animal drawn equipment,

tractor, power tiller, power operated machine, self propelled machines and work places. The data for 12525 agricultural workers (8025 male and 4500 female) from 12 states were collected. For body measurement, the equipment used was either Harpenden Anthropometer or Sieber Hegner Anthropometer or IIT Kharagpur Anthropometer. The equipment used for measurement of strength parameter was strength measurement setup developed at CIAE, Bhopal.

Yadav *et al.* (2018) carried out an anthropometric survey for female agricultural workers of Gujarat State. A group of 382 female agricultural workers were selected and 38 body dimensions were precisely measured and recorded from each subject. The data measured were statically analyzed for mean, standard deviation, 5th and 95th percentile values which are used in design. In the study, a set of 19 body dimensions, which are having direct implication on agricultural tool/implement design were selected, and compared with data of different states of India and also with other countries female workers. The mean weight and stature of female agricultural workers were found to be 48 kg and 1522 mm, respectively. A large variation in anthropometric workers was observed in the anthropometric data of female workers of different states of India and other countries.

2.8 REVIEW SUMMARY

1. Handle height should be within 0.7 to 0.8 times of shoulder height (100 cm for Indian workers) and handle angle with horizontal should be 30° for minimum force application.
2. Push/Pull type weeder required single person for weeding operation.
3. Weed species create heavy financial losses in crop production across the world.
4. Weed management in India estimates that of the annual world output losses caused on by pests (insects, illnesses they spread, and weeds), weeds account for one third of them.
5. Human-powered equipment is inexpensive and affordable to all.
6. A wheel hoe that is operated manually Unlike a tractor or a power-operated weeder, the equipment does not require any outside force to work.

7. A mechanical hoe is one type of weeder that is both less labor-intensive and more effective at weeding.
8. Mechanical techniques are the most effective weed control strategy. As a result, it is essential to create a mechanical weeder that is small, light, compact, causes the least amount of plant damage, can be handled by just one person, and also reduces drudgery and fatigue.
9. To assess the worker's performance with respect to the developed weeder, an ergonomic study of the worker is required.

CHAPTER - III

MATERIALS AND METHODS

This chapter deals with the theoretical considerations, crop and functional parameters, procedures and methodology involved in the development of a manually operated finger weeder and its performance evaluation for the selected crops. The specification of each part of the developed manual weeder like handle, frame, finger disk, tines and ground wheel is given in this chapter.

To evaluate the performance parameters of developed finger weeder i.e. speed, draft required, effective field capacity, etc. three different operators were selected to operate the developed weeder.

3.1 THEORETICAL CONSIDERATIONS

Weeding is a process of uprooting unwanted plants at an early stage to ensure plant growth. The root crops require weeding, so that competition between main plants and their adjacent weeds is reduced and the main plant can grow to a profitable size. For each crop to get maximum productivity removal of unwanted plants or weeds are necessary. Generally, the weeding is done by

- a) Manual labour
- b) Chemical and herbicides
- c) Mechanical weeding

The mechanical weeders are mostly used in developed countries. Mechanical weeding is done either with machines that are operated in space available between the row-to-row spacing, along the rows of crops.

3.2 DESIGN CONSIDERATIONS

3.2.1 Crop Parameters

The package of practices and agronomical requirements of the selected crops were studied. The crops under study were blackgram and groundnut and it is grown in Rabi season, at the row spacing of 45 cm with a plant-to-plant spacing of 8 to 10 cm within the range of row spacing as well as plant spacing, it is mostly practiced with closer the rows and wider the plant spacing and vice versa, to facilitate the plants for



optimum growth. Mostly, they required 1 to 2 weeding operations in 15 to 20 days after sowing

Fig. 3.1 Experimental field of groundnut and blackgram crop

3.2.1.1 Type of crop

Groundnut and blackgram crops were selected for the experiment. The views of the experimental field are presented in Fig. 3.1.

3.2.1.2 Row and plant spacing

The row-to-row and plant-to-plant spacing were measured at the time of weeding with the help of measuring tape and scale. The details of these parameters are presented and discussed under section 4.1.1.2.



Fig. 3.2 Measurement of row-to-row spacing

3.2.1.3 Crop canopy

The canopy of the plant is an important aspect of crop growth. Measuring tape was used to measure the crop canopy, for which ten plants were selected at random to measure the breadth and length of groundnut and blackgram crops at regular intervals.



Fig. 3.3 Measurement of crop canopy

3.2.1.4 Crop height

One of the most important parameters in weeding consideration is plant height. The height of a randomly selected groundnut and blackgram crop was measured using a scale and steel tape.



Fig. 3.4 Measurement of crop height

3.2.2 Functional Parameters

1. The finger weeder device should be suitable for interculturing along the rows to control weeds.
2. The device should remove the unwanted plants at the desired depth and throw away them in such a way that the desired plants should not be disturbed.
3. The draft requirement for the operation should be within the limit of human power.
4. The device should be easily adjustable according to the height of the operators.
5. The design should be simple and easily repairable.
6. The cost of fabrication and operation should be affordable as well as economical.
7. Physiological parameters of crop plants.
8. Weeding should be done at the early growth stages of the weeds.
9. Local availability of the materials.
10. A reasonable amount of space and weight is required to allow moving it to the site.

3.3 DESIGN OF MAIN COMPONENTS

Most of the farmers of this region carry out their field operations with the help of either manual labour or mechanical weeder. This implement can be used for weeding purposes. Keeping in view this implement, the mechanical weeding device was considered to design and develop, suitable for operators. The detailed dimensions of the implement are as under

The developed mechanical finger weeder consists of.

1. Handle
2. Main frame
3. Finger disc
4. Tines
5. Ground wheel

3.3.1 Handle

The handle is one of the most important parts of the weeder. The handle was provided for controlling the movement and applying force on the finger weeder by the

operator. It was fabricated from 2 mm thick MS pipe with a circular cross-section. Rubber grips of 125 mm in length are provided at each end of the pipe for ease of handling and to minimize unexpected shocks. The desired height of the handle from the ground surface is obtained with the adjusting support with the help of the handle beam, the handle was connected to the main frame. The handle was fabricated from 25.5 mm diameter pipe (IS: 1976 - 1976). Handle consists of two MS round pipes having diameter 25.5 mm and 2 mm thickness. The length of each pipe is 1200 mm. A MS sheet plate was also attached with a provision to change the angle for the application of force. The overall length of the handle beam is 1400 mm. The dimension of the handle is depicted in Table 3.1. The view of the handle of the developed finger weeder is depicted in Fig. 3.5.

Table 3.1 Dimensions of handle

Sr. No.	Particular	Value (mm)
1.	Overall length of handle	1400
2.	Length of handle grip	125
3.	Grip diameter	33.30
4.	Pipe thickness	2
5.	Pipe diameter	25.5
6.	Length of handle	1200
7.	Lower end spacing between handle	250

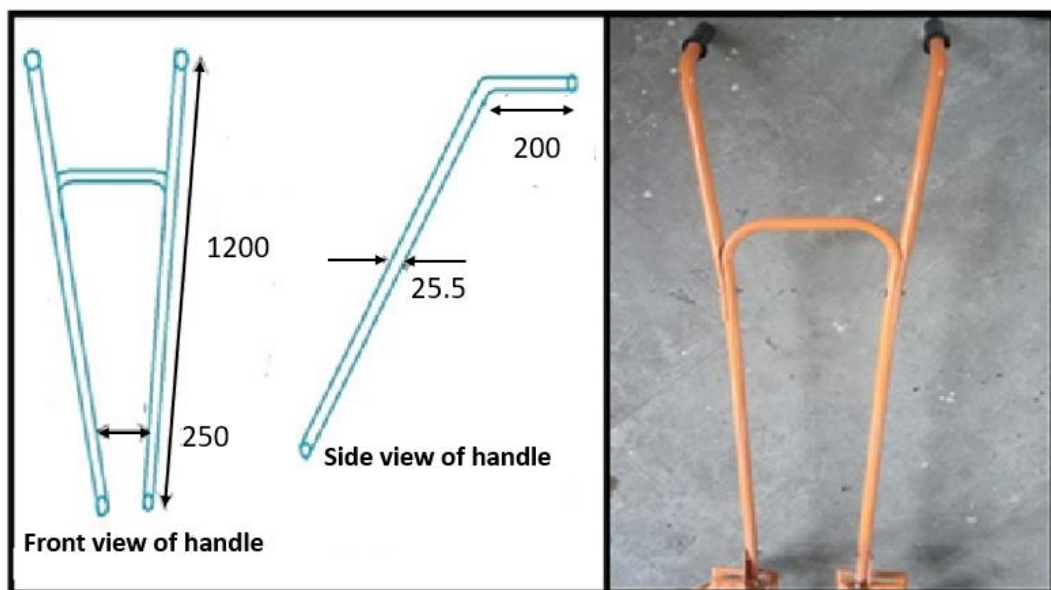

Fig.3.5 View of handle of developed finger weeder (all dimensions are in mm)

3.3.2 Frame

The component like tines and finger disc assembly is required to attach with a frame and looking to lower the cost of construction of finger weeder. The purpose of the frame is to support all the components required for the smooth operation of the developed finger weeder (handle, finger disc, tines, wheels, etc). The frame was fabricated from galvanized iron pipes with rectangular cross sections of 25×3 mm, 20×3 mm and a thickness of 2 mm, such that the overall dimensions of the frame are 700×350 mm, as shown in Fig. 3.6 and 3.7. Two MS flat end plates were welded on the frame, The purpose of providing MS flat plates was to attach the frame nuts and bolts were used to connect the handle to the frame and we can adjust the frame height up to (280 mm) according to crop height. The detailed dimensions of the main frame are given in Table 3.2

Table 3.2 Dimensions of the frame

Sr. No.	Particulars	Value (mm)
1.	Length	350
2.	Width	700
3.	Thickness	2
4.	Frame height	215
5.	Frame height from ground	420
6.	Frame adjustable height	65

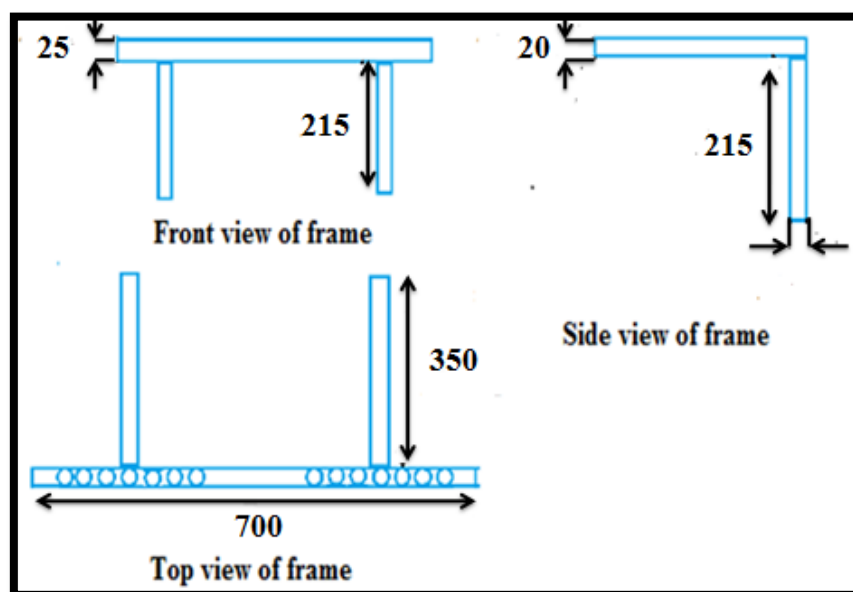

Fig. 3.6 Different views of frame (all dimensions are in mm)

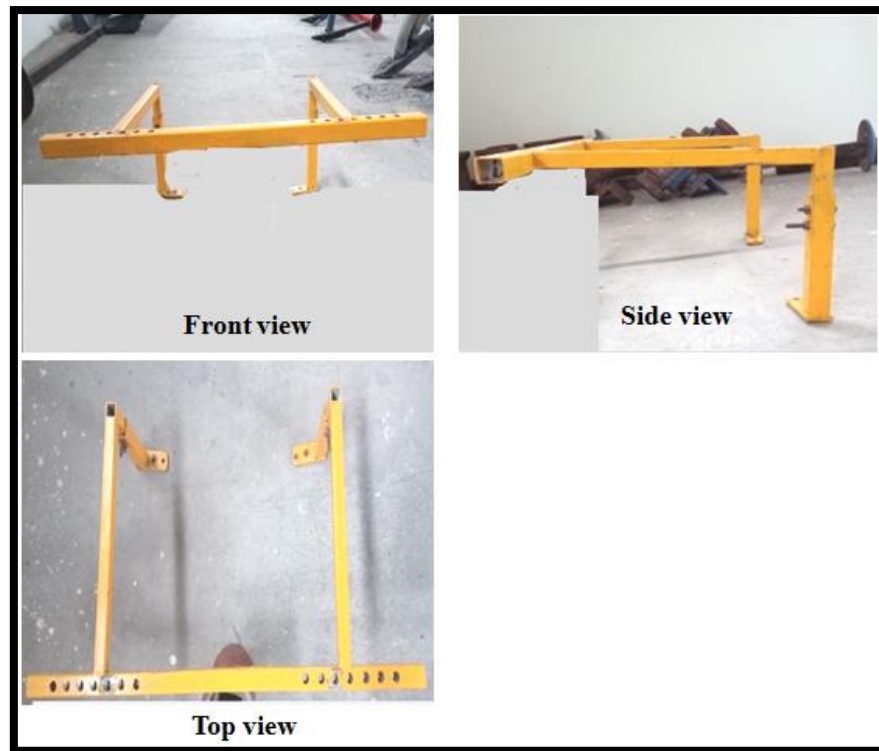

Fig. 3.7 Different views of frame of developed finger weeder

3.3.3 Finger disc

A finger disc was fixed on the mainframe which was fitted with a shaft by nut and bolt. The function of the finger disc is to dig up the layer of the soil and remove the weeds. The finger disc was made up of cast iron material. The concept of finger disc was considered, finger weeder is operated by push action and it allows moving of the finger disc by ground driven. The idea was only to penetrate the soil and uproots the weeds in the crop rows. It also removes the weeds growing near the crops. It consists of 12 fingers on each finger disc and 6 rectangular-shaped inclined flat finger discs attached to the bottom side of the finger disc. The fingers are detachable. Because of the bushing, the finger disc rotates freely on the shaft. The overall diameter of the finger disc and length of the finger is 381 mm and 114.3 mm. The diameter and thickness of the bottom disc are 282 mm and 3 mm. The fingers were provided with a sharpened lower end so they can penetrate the soil at a proper angle and get the desired depth during weeding. The inclined flat finger disc is also sharpened at the lower end so it can penetrate the soil at a proper angle and get the desired depth. A finger discs are adjustable and 30° working angle found with horizontal. The dimensions of the finger disc are given in Table 3.3 and a view of the finger disc of a developed finger weeder is depicted in Fig. 3.8 and 3.9.

Table 3.3 Dimensions of finger disc

Sr. No.	Particulars	Value (mm)	Sr. No.	Particulars	Value (mm)
1.	No. of finger disc	2	10.	Angle of flat finger disc	120 ⁰
2.	Overall diameter of finger disc	381	11.	Adjustable finger disc width	170
3.	Length of finger	114.3	12.	Shaft diameter	19
4.	Diameter of finger	12	13.	Shaft length	370
5.	Sharp side finger diameter	6	14.	Bushing inner diameter	19.25
6.	Shaft angle	150	15.	Bushing outer diameter	25
7.	Length of flat finger	65	16.	Bushing length	40
8.	Width of flat finger	20	17.	Inclined flat finger disc diameter	282
9.	Thickness of flat finger	3			

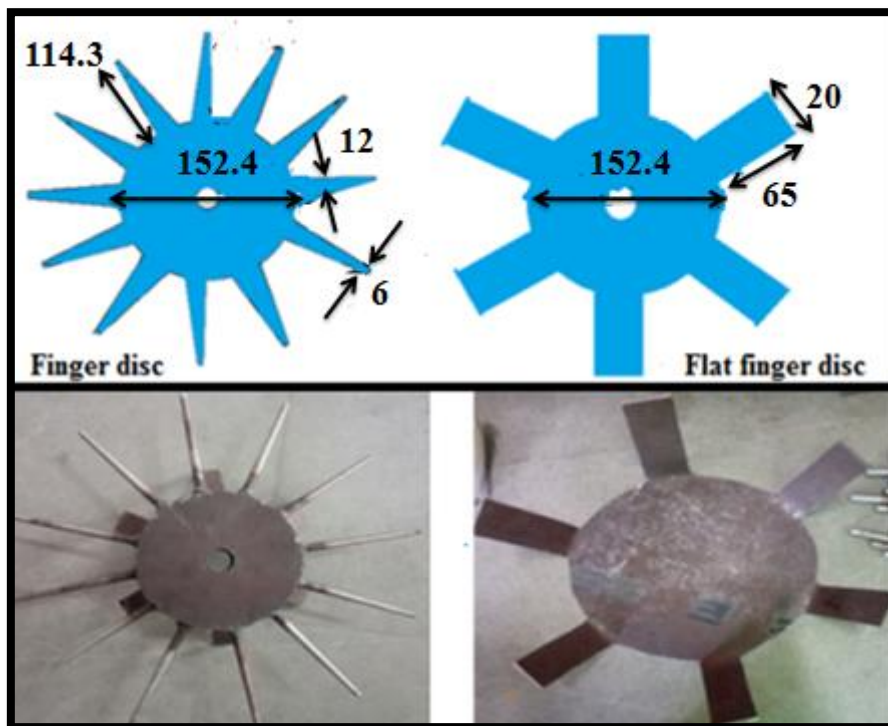

(a)

(b)

Fig. 3.8 (a) Finger disc (b) Flat finger disc (all dimensions are in mm)

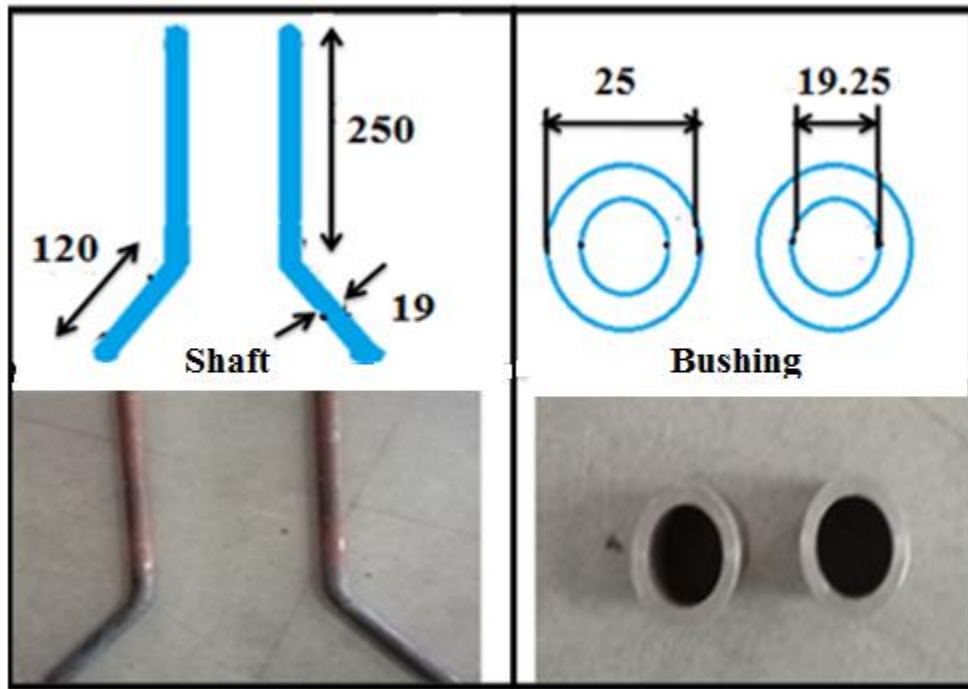

(c)

(d)

Fig. 3.9 (c) Shaft and (d) Bushing (all dimensions are in mm)



Fig. 3.10 View of finger disc attachment

3.3.4 Tines

The tines were fabricated from MS flat having a height of 250 mm, a width of coverage 120 mm and 3 mm thickness. A tines were fixed on the main frame which fitted by the nut and bolt. The function of the tines is to penetrate or lift off the soil and uproot the weeds. These tines are fabricated to work in the soil under the interaction of different soil forces. Therefore, the strong metal was selected to sustain the prevailing forces, as well as to support the load of the implement. The tines are sharpened at the lower end so that they may penetrate the soil at the right angle and get the desired depth when weeding. The tines have a 20-30 mm depth of cut and 15° working angle found. Fig. 3.11 shows the tines constructional specifications, whereas the tines are adjustable.

Table 3.4 Dimensions of tines

Sr. No.	Particulars	Value (mm)	Sr. No.	Particulars	Value (mm)
1	No. of tines	2	4.	Width of tines	120
2.	Height of tines from ground	250	5.	Thickness of tines	3
3.	Overall height of tines	250	6.	Adjustable width of tines	90

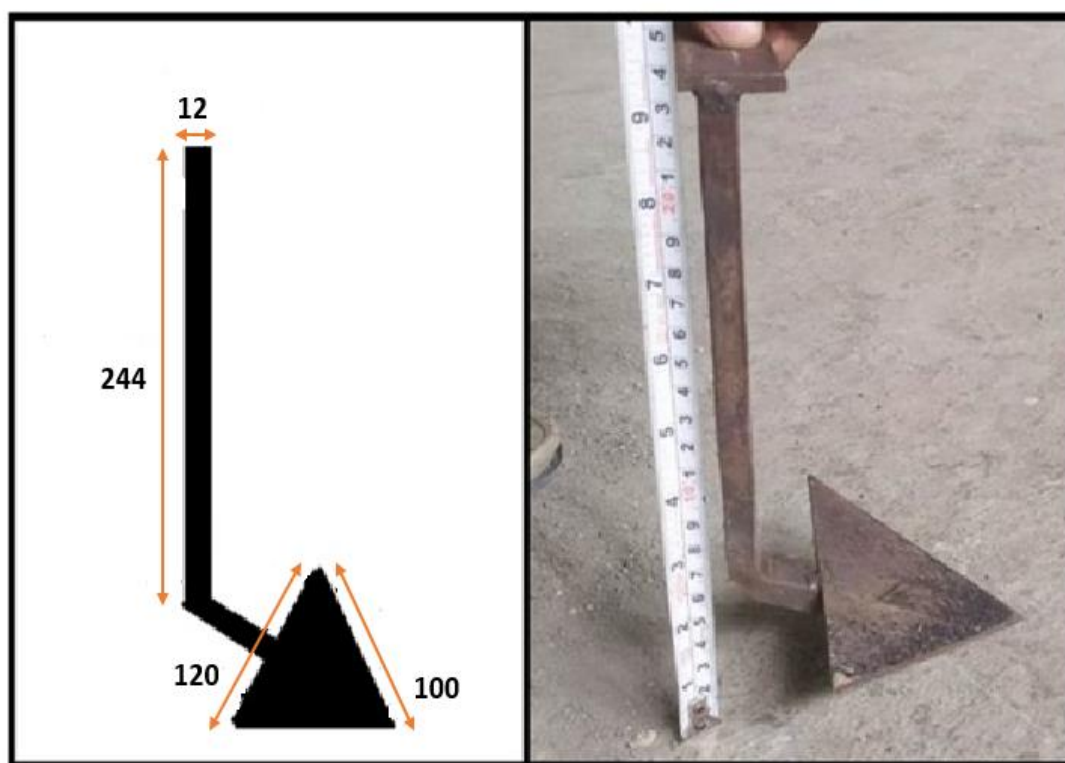
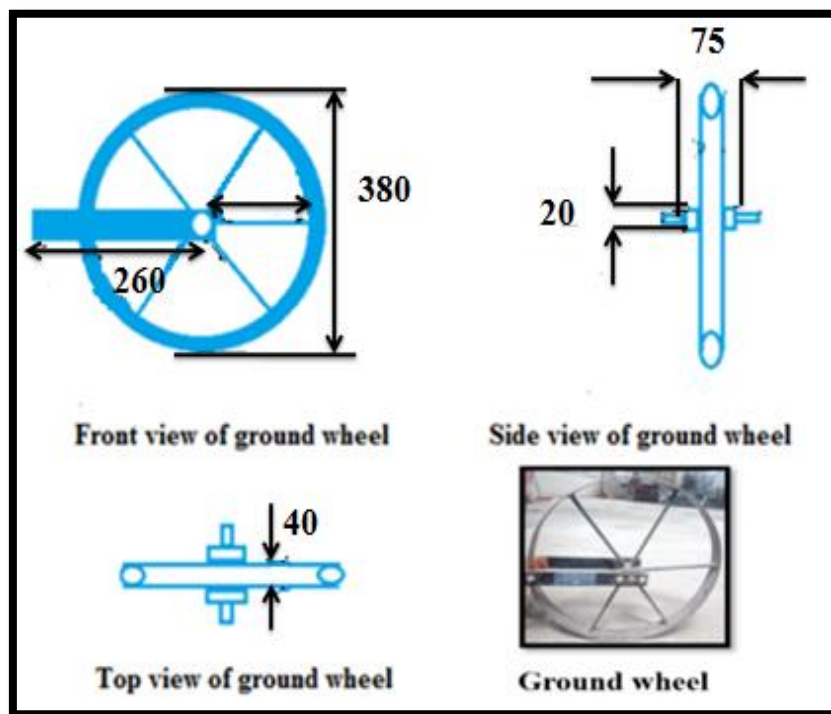

Fig. 3.11 View of tines of developed finger weeder (all dimensions are in mm)**3.3.5 Ground Wheels**

The ground wheel was fabricated from MS flat. The weeder consists of two wheels. The overall diameter and width of ground wheels are 380 mm and 40 mm and thickness of 3 mm. The wheel hub was made of mild steel having length, outer diameter and inner diameter of 75 mm, 20 mm and 10 mm, respectively. There are 6 spokes provided between the rim and wheel hub and two wheels are separated from each other. Fig. 3.12 shows the ground wheel constructional specifications.

Table 3.5 Dimensions of ground wheel

Sr. No.	Particulars	Value (mm)	Sr. No.	Particulars	Value (mm)
1	No. of ground wheels	2	6.	Hub outer diameter	20
2.	Overall diameter	380	7.	Hub inner diameter	10
3.	Width	40	8.	No. of spokes	6
4.	Thickness	3	9.	Diameter of spokes	8
5.	Hub length	75	10.	Length of spokes	180

**Fig. 3.12 View of ground wheel of developed finger weeder (all dimensions are in mm)**

3.3.6 Different Views of Developed Finger Weeder

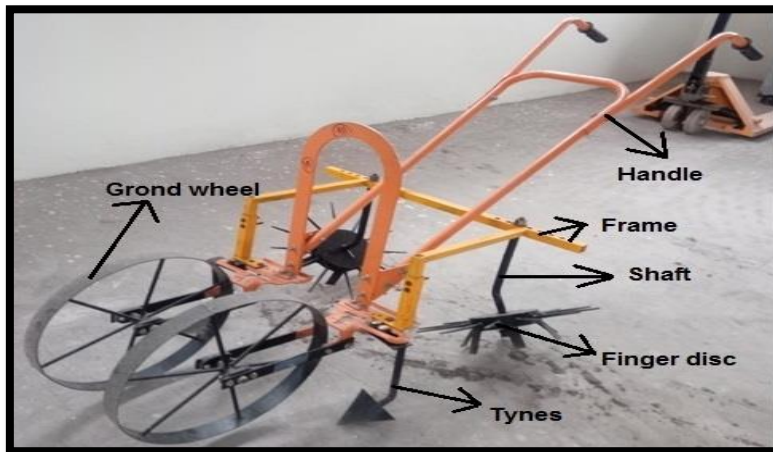

Fig. 3.13 Isometric view of developed finger weeder



Fig. 3.14 Top view of developed finger weeder



Fig. 3.15 Front view of developed finger weeder



Fig. 3.16 Side view of developed finger weeder

3.4 MATERIAL FOR CONSTRUCTION

Different sized MS flats, round bars and GI square pipe were used for the fabrication of the drive unit and frame. The tines of the weeding unit were fabricated from 3 mm thick M.S. plate.

3.5 EXPERIMENTAL PROCEDURE

The manually drawn finger weeder was tested in medium black soil at the field of Dept. of Agronomy and Pulse Research Station, JAU, Junagadh. The size of the test plot for each crop was kept at 0.05 ha. The weeding operation was carried out with the help of single labour. The observations like draft, speed, depth of cut, width of cut, etc are discussed in Chapter IV. The performance of the finger weeder was evaluated and compared with manual weeding in terms of parameters such as man-hours requirement, energy consumption and cost of operation.

3.5.1 Moisture Content of the Soil

The soil moisture content was determined on dry weight basis soil samples were collected randomly from the test field. The samples were weighed in a physical balance and were kept in a hot air oven maintained at a temperature of 105 °C for 24 hours. The samples were weighed after drying. The soil moisture was calculated by using the formula given below.

$$\text{M. C.} = \frac{(\text{wt. of wet soil} + \text{box}) - (\text{wt. of dry soil} + \text{box})}{(\text{wt. of dry soil} + \text{box}) - (\text{wt. of empty box})} \quad \dots (3.1)$$



Fig. 3.17 Measurement of soil moisture content

3.5.2 Bulk Density of Soil

The metallic core sampler was used to take the sample from a field having 100 mm diameter and 128 mm length. The samples were weighed and the weight of the samples was calculated from the moisture content, the ratio of the weight of soil to the volume gave the bulk density. The bulk density was calculated as illustrated in Appendix – B. Fig. 3.18 depicts the measurement of weight for bulk density. The bulk density of the soil at the time of field operation was determined by using the following formula.

$$\text{Bulk density (g/cc)} = W/V \quad \dots (3.2)$$

Where,

W=Wt. of soil (g)

V=Volume of soil (cm³)



Fig. 3.18 Measurement of bulk density of soil

3.5.3 Depth and Width of Cut

The depth of cut was determined by the vertical distance between the horizontal surfaces to the bottom of the disturbing part between rows. The width of cut was measured by the horizontal length of cut perpendicular to the row. Fig. 3.19 shows the measurement of the depth of cut using a depth gauge.



Fig. 3.19 Measurement of depth of cut using depth gauge

3.5.4 Draft Requirement

The draft requirement for the manually operated finger weeder device can be calculated based on the maximum push developed by humans. The horizontal component of push in the line of motion is considered a draft. The draft of the developed weeder was measured with the help of a load indicator arrangement fitted at the handle beam of the weeder. The angle between the line of push and the direction of travel was measured. Here, the draft can be measured directly by the load indicator which shows the amount of push applied in operation. The draft can be calculated as, the spring-type load indicator (0-100 kg) was mounted between the handle to measure the push supplied by the operator while operating the weeder in the forward direction. The load indicator measured the push in kilograms. The cross-sectional view of the telescopic arrangement spring type load indicator is depicted in Fig. 3.20.

$$\text{Draft (kg)} = P \cos \theta \quad \dots (3.3)$$

Where,

P = Push (kg)

θ = Angle of inclination (degree)



Fig 3.20 View of spring-type load indicator

3.5.5 Operating Speed

Outside the long boundary of the test plot, two points 10 m apart were marked approximately in the middle of the test run. The time required to travel the distance of 10 m was recorded and the speed of operation was calculated. A stopwatch was used to record the time taken by the implement to travel the marked distance during the operation. Then, it was determined in km/h. Speed was calculated with the help of the following formula.

$$\text{Speed of travel } \left(\frac{\text{km}}{\text{h}} \right) = \frac{\text{Length covered (m)}}{\text{Time taken to cover length (s)}} \times \frac{5}{18} \quad \dots (3.4)$$

3.5.6 Time Loss

a) In turning

The time taken in turning at the end of each row was observed and recorded. Then, the total time loss in turning per unit area worked out.

b) In adjustment

The time required for adjustment of the device was recorded and reported

3.5.7 Plant Damage

During the weeding operation, the plant damage was observed in terms of buried plants by soil mass as well as cutting of plant leaves/tops by rotating action of finger disc and tines the percentage of plant damage was then worked out. The number of damaged plants was recorded based on plant population in a unit area

before and after the weeding operation. It is expressed as a percentage. The details of these parameters are presented and discussed under section 4.3.2.5.

$$\text{Plant damage percentage (percentage)} = \frac{q}{p} \times 100 \quad \dots(3.5)$$

Where,

q = Number of damaged plants in sample plot

p = Total number of plants in sample plot

3.5.8 Weeding Efficiency

The unwanted plants removed by the operation of the device before and after the weeding operation in blackgram were counted for determining the weeding efficiency. In the same way, it was also calculated for Ground nut crop Fig. 3.21 and 3.22 shows the views of plots before and after weeding of crops under study. A row length of 10 m was considered and plants in a row before and after the weeding operation were counted. The weeding efficiency was calculated with the help of the following formula. (Tajuddin, 2006).

$$\text{Weeding efficiency(\%)} = \frac{X - Y}{X} \times 100 \quad \dots (3.6)$$

Where,

X = No. of weeds before operation,

Y = No. of weeds after operation



Fig. 3.21 Weed counting before and after weeding on blackgram field



Fig. 3.22 Weed counting before and after weeding on groundnut field

3.6 DETERMINATION OF POWER REQUIREMENT AND EFFICIENCY

The power requirement, field capacity and field efficiency for each crop were calculated with the help of formulae given below.

(a) Power

The amount of power required to operate the weeder was calculated with the help of the following formula.

$$\text{HP} = \frac{\text{Draft (kg)} \times \text{speed (m/s)}}{75} \quad \dots (3.7)$$

(b) Theoretical field capacity

Theoretical field capacity is the rate of coverage of an implement based on 100 percent of the time at rated speed and covering 100 percent of its rated breadth. It was calculated with the help of the following formula (Kepner *et al.*, 1982)

$$\text{Theoretical field capacity} \left(\frac{\text{ha}}{\text{h}} \right) = \frac{\text{Width of coverage (m)} \times \text{speed} \left(\frac{\text{km}}{\text{h}} \right)}{10} \quad \dots(3.8)$$

(c) Effective field capacity

The effective field capacity of the weeder is calculated by fixing the area of which had the fixed length and fixed width. This is the actual area covered by the weeder. The field capacity of the weeder was determined in terms of ha/h. It was calculated using the following formula.

$$\text{Effective field capacity} \left(\frac{\text{ha}}{\text{h}} \right) = \frac{\text{width of coverage (m)} \times \text{length of strip (m)}}{\text{time taken (hr)} \times 10000} \quad \dots(3.9)$$

(d) Field efficiency

The ratio of effective field capacity and theoretical field capacity expressed in percentage is known as field efficiency. The same was calculated using the following formula (IS: 7927-1975):

$$\text{Field efficiency (\%)} = \frac{\text{Effective field capacity}}{\text{Theoretical field capacity}} \times 100 \quad \dots (3.10)$$

(e) Energy Consumption

The finger weeder was operated manually in the field. The human energy utilized in the weeding operation in the field for weeder was evaluated using the following formula. (Chaudhary *et al.*, 2006)

$$E_m = 1.96 N_m T_m \quad \dots(3.11)$$

Where,

N_m = Number of labours spent on farm activity

T_m = Useful time spent by labour on a farm activity (h/ha)

E_m = Manual energy expended (MJ/ha)

3.7 ERGONOMIC EVALUATION

Physiological and subjective evaluations of each parameter were used to assess ergonomics. Heart rate, oxygen consumption rate and energy expenditure rate were determined during a physiological evaluation.

3.7.1 Physiological Evaluation**(a) Heart rate**

The heart rate is the number of heart contractions per minute multiplied by the speed of the heartbeat. It is expressed in bpm (beats per minute). It was measured using technology that detects the heartbeat directly and displays the reading in beats per minute (bpm) (Anon., 2016).

(b) Oxygen consumption rate

The amount of oxygen used by the body's tissues, commonly measured as oxygen uptake in the lungs, is known as the oxygen consumption rate. It rises in tandem with a rise in metabolic rate. It is expressed in liters per minute (l/min) or

milliliters per minute (ml/min), it was calculated by the following equation (Singh, 2012).

$$Y = (0.0114X) - 0.68 \quad \dots (3.12)$$

Where,

Y = Oxygen consumption, l/min

X = Heart rate, beat/min

(c) The energy expenditure

The energy expenditure rate indicates the level of body stress in relation to heavy work. It is used to assess the level of effort to work out the necessary rest period and to compare the efficiency of different tools (Upender *et al.*, 2018). Heart rate is one of the most accurate means of studying energy expenditure while performing any activity (Hasalkar *et al.*, 2004).

The energy expenditure was calculated by multiplying the oxygen used by the subject during the trial period by the calorific value of 20.93kJ/l of oxygen (Nag and Dutta, 1980). The energy cost of the subject thus obtained is graded as per the tentative classification of strain in different types of jobs given in the ICMR report as shown in Table 3.6 (Sen, 1969 and Sam, 2014).

$$\text{Energy expenditure (kJ/min)} = \text{Oxygen consumption (l/min)} \times \text{Calorific value of oxygen (kJ/l)} \quad \dots(3.13)$$

Table 3.6 Classification of manual jobs based on the physiological response of Indian male workers (Sen, 1969)

Grading of work	Physiological response		
	Heart rate (beats/min)	Oxygen uptake (l/min)	Energy expenditure (Kcal/min)
Very light	<75	<0.35	<1.75
Light	75-100	0.35-0.75	1.75-3.50
Moderately heavy	100-125	0.75-1.05	3.50-5.25
Heavy	125-150	1.05-1.40	5.25-7.00
Very Heavy	150-175	1.40-1.75	7.00-8.75
Extremely heavy	>175	>1.75	>8.75

3.7.2 Anthropometry Data

The design of an efficient workplace configuration workplace should be done by considering the anthropometric data users' population. The location of the hand and foot-operated control should be within easy reach of the operators. These data help to determine various parameters that affect the operator's physiological aspects. This anthropometric data was used for designing equipment. The anthropometric parameters which are mainly affected in weeding operations are given in Table 3.7

Table 3.7 Basic body dimensions of weeder operators

Sr. No	Parameters	S ₁	S ₂	S ₃
1.	Age (years)	24	23	22
2.	Sex	Female	Male	Male
3.	Weight (Kg)	50	72	65
4.	Stature (cm)	167.6	177.8	172.7
5.	Standing eye height (cm)	158	167.3	164.2
6.	Acromial height (cm)	140.5	147.2	144.3
7.	Elbow height (cm)	109.8	112.8	111.6
8.	Knee height (cm)	48.2	51	50.4
9.	Illicrystale height (cm)	98.5	101.8	100.2
10.	Bideltoid breadth (cm)	44.2	44.8	44.5
11.	Inside grip diameter (cm)	5	5.3	5.2
12.	Middle finger palm diameter(cm)	2.5	3	2.8
13.	Palm breadth without thumb (cm)	7.8	9.7	9.3
14.	Palm breadth with thumb (cm)	9.5	11.6	11.4
15.	Palm length (cm)	8.5	10.2	10.8
16.	Palm thickness (cm)	18	2.7	2.5
17.	Heart rate (bpm)	89	92	93
18.	Normal energy expenditure kcal/h	228.7	307.6	288



Fig. 3.23 Measurement of anthropometric

3.8 ECONOMICAL CONSIDERATIONS

3.8.1 Manual Weeding

The working capacity of human labour varies in the course of a day. Generally, it is higher in the morning and declines in the middle of the day. Again in the afternoon, it increases for a short period and then falls rapidly. It also depends upon the weather condition and kind of field work. The manual weeding of crop plants is mostly performed in a bending posture, which rapidly increases fatigue. During the experiment, the time required for manual weeding per unit area for each crop under study was observed and considered for the calculation of the cost of manual weeding. The prevailing rate of Rs. 300 per day of eight hours for the manual weeding operation was considered. Based on actual operating hours, the cost of operation by manual weeding was calculated.

3.8.2 Mechanical Weeding

3.8.2.1 Cost of operation

The cost of operation for a particular finger weeder was worked out by the straight-line method as given in Appendix IV. As the width of coverage and speed of operation for the blackgram and groundnut differs from each other, which affects the cost of operation was determined separately and the total cost of use of the finger weeder was worked out. The prevailing rate of Rs. 300 per day for eight hours for the operator was considered. The cost of operation (Rs) of the finger weeder in terms of a

hectare, as well as hour, was calculated considering fixed costs and variable costs involved in the operation. The cost of weeding operation performed for all treatments was worked out based on the prevailing input and fabrication price of the implements, machinery and rental wages of operator and labours if required. The cost of operation of a finger weeder is divided into two heads known as fixed cost and operation cost, where fixed cost is independent of operational use while variable cost varies proportionally with the amount of use. (Kamboj *et al.*, 2012). Cost of weeding operation for finger weeder was calculated in Rs/ha.

3.8.2.1.1 Fixed Cost

The fixed cost includes depreciation, interest on the capital cost, housing, insurance and taxes.

(a) Depreciation

It is a measure of the amount by which the value of the machine decreases with the elapsed time. According to Kepner *et al.* (2017), the annual depreciation was calculated by using the formula

$$D = \frac{C - S}{L \times H} \quad \dots(3.14)$$

Where,

D = Depreciation per hour

C = Capital investments (Rs.)

S = Salvage value, 10% of capital investment (Rs.)

L = Life of machine in hours or years

(b) Interest

Interest was calculated on the average investment of the machine taking into consideration the value of the machine in the first and last year. This is usually calculated on yearly basis. The annual interest on the investment can be calculated using the formula (Kepner *et al.*, 1978).

$$I = \frac{C+S}{2} \times \frac{i}{H} \quad \dots (3.15)$$

Where,

I = Interest per hour (Rs. /h)

i = 10 % per year

(c) Taxes and insurance

The insurance charge is generally considered as 1% of the initial cost of the machine and usually for a year.

(d) Housing

Housing cost was calculated based on the prevailing rates in the locality, but roughly, the housing cost is also considered either on actual expenditure or 1% of the initial cost of the machine per year.

3.8.2.1.2 Operating cost

Operation cost includes fuel, lubricants, repair and maintenance costs and wages.

(a) Repair and maintenance cost

The repair and maintenance cost are generally taken as 2.5% of the purchase price or capital investment per year (Kepner *et al.*, 2017 and Kamboj *et al.*, 2012).

$$\text{RM} = 2.5\% \times \text{Purchase price or capital investment per year} \quad \dots(3.16)$$

(b) Wages of operator

Actual wages paid to the worker were considered and that too on hour basis.

3.8.2.1.3 Total Cost of Weeding Per Hour

The total cost of weeding per hour of the developed finger weeder was calculated by summation of all the fixed costs per hour and all the variable costs per hour.

$$\text{Total Cost} \left(\frac{\text{Rs.}}{\text{h}} \right) = \text{Fixed cost} \left(\frac{\text{Rs.}}{\text{h}} \right) + \text{Variable cost} \left(\frac{\text{Rs.}}{\text{h}} \right) \quad \dots(3.17)$$

3.8.3 Economical Comparison of Mechanical Weeding with Manual Weeding

The requirement of man-hours, energy and cost of operation of a mechanical finger weeder was compared with a traditional weeding i.e., manual weeding observe the feasibility of mechanization of weeding operation and it is reported in Chapter IV.

CHAPTER - IV

RESULTS AND DISCUSSION

A manually operated weeding device was developed on the basis of crop and functional parameters. The developed units and parts were fabricated and assembled in the workshop. The working performance was evaluated in terms of depth and width of cut, field capacity, field efficiency, draft requirement, plant damage and weeding efficiency. The energy requirement and cost of operation were also worked out. The observations and interpretation of results obtained under actual field conditions are presented and discussed in this chapter.

4.1 DESIGN CONSIDERATIONS

4.1.1 Crop Parameters

The crops under study, the blackgram and groundnut are grown in Rabi season, at the row spacing range of 45 cm with a plant-to-plant spacing range of 8 to 10 cm. within the range of row spacing as well as plant spacing, it is mostly practiced with closer the rows and wider the plant spacing and vice versa, in order to facilitate the plants for optimum growth. Proper weeding operation in the row is possible manually or mechanically, which is necessary to maintain the proper plant growth for maximum yields.

4.1.1.1 Type of crop

For the Rabi season, there are varieties of crops to choose for the experiment, from that the field of groundnut and blackgrams were chosen.

4.1.1.2 Row and plant spacing

Row to row and plant to plant spacing was measured with the help of measuring tape. Table 4.1 present the row and plant spacing of the crop.

Table 4.1 Row and plant spacing of selected crops

Sr. No.	Crops	Row Spacing (cm)	Plant spacing (cm)
1.	Groundnut	45	8-10
2.	Blackgram	45	8-10

4.1.1.3 Crop canopy and crop height

Crop canopy and crop height was measured of a randomly selected plant. Table 4.2 present the crop canopy and crop height of groundnut and blackgram.

Table 4.2 Canopy and height of selected crops

Sr. No.	Crops	Length (cm)	Breadth (cm)	Height (cm)
1.	Groundnut	16.2	17.5	16.0
		14.9	15.3	14.3
		18.5	19.4	12.5
2.	Blackgram	8.9	9.3	18.3
		7.8	8.2	20.2
		10.2	10.4	16.5

4.1.2 Functional Parameters

1. Suitability of the finger weeder for varying row spacing as well as plant spacing
2. Removal of the unwanted plants from the row to maintain the desired plant growth.
3. Easily adjustable according to the operator.
4. Economical in fabrication and operation.

4.2 DESIGN OF MAIN COMPONENTS

The manually operated finger weeder was developed on the basis of crop and functional parameters, soil characteristics, as well as engineering aspects viz., push, soil resistance and power availability. It consisted of a handle, frame, tynes, finger disc and ground wheels. At the earlier stage of the development, all components were developed. As shown in section 3.3, the dimensions have been given in Chapter III.

4.2.1 Specification of Developed Finger Weeder

The specifications of the developed finger weeder are given in Table 4.3.

Table 4.3 Detailed specifications of the developed finger weeder

Sr. No.	Particulars	Value (mm)
1.	Name of the equipment	Manually drawn finger weeder
2.	Type of action and its detail	
	Action	Push type
	Power source	Manually operated (single person)
3.	Overall dimensions	
	Length	1720
	Width	920
	Height	1080
	Weight (Kg)	12
4.	Handle	
	Material of construction	MS pipe
	Diameter	25
	Length	1400
	Pipe thickness	2
	Handle grip	125
	Handle grip diameter	33
	Lower spacing between handle	250
5.	Frame	
	Material of construction	G.I. rectangular pipe
	Length	350
	Width	700
	Thickness	2
	Length of wheel housing plate	270
	Width of wheel housing plate	30
	Thickness of wheel housing plate	4
6.	Finger disc	
	No. of finger disc	2
	Overall diameter of finger disc	381

	Length of finger	114.3
	Diameter of finger	12
	Sharp side finger diameter	6
	Bottom disc diameter	280
	Length of rectangular strip	65
	Width of rectangular strip	20
	Thickness of rectangular strip	3
	Shaft diameter	19
	Shaft length	380
	Bushing inner diameter	19.25
	Bushing outer diameter	25
	Shaft angle	150
7.	Tines	
	No. of tines	2
	Height of tines from ground	230
	Overall height of tines	230
	Width of tines	120
	Thickness of tines	3
8.	Ground wheel	
	No. of ground wheels	2
	Overall diameter	380
	Width	40
	Thickness	3
	Hub length	75
	Hub outer diameter	20
	Hub inner diameter	10
	No. of spokes	6
	Diameter of spokes	8
	Length of spokes	180

4.3 PERFORMANCE EVALUATION OF DEVELOPED FINGER WEEDER

The manually operated finger weeder was tested for its working performance in the field plots of blackgram and groundnut. Pre-test observations were taken.

4.3.1 Pre-Test Observations

4.3.1.1 Moisture content of the soil

The oven dry gravimetric method was used to determine the moisture content of the soil. The soil moisture content of the groundnut and blackgram experimental field at the time of weeding was determined on a dry basis as 17.15 % and 20 % respectively (Appendix-A).

4.3.1.2 Bulk density

A core sampler approach was used to determine the bulk density of the soil at the time of weeding in both experimental fields. The bulk density was found as 1.64 grams per cubic centimeter for groundnut field and 1.65 grams per cubic centimeter for blackgram field. Appendix B contains the results related to average bulk density.

4.3.2 Field Observations

4.3.2.1 Depth and width of cut

At the time of weeding of groundnut and blackgram, the average depth of cut was found as 2.3 and 2.2 cm as shown in Table 4.4. The width of cut of the developed finger weeder was measured as 85 cm, whereas the width of cut is adjustable.

Table 4.4 Depth and width of cut of developed finger weeder

Sr. No.	Particular	I	II	III	Average
1.	Depth of cut ingroundnut (cm)	2.5	2.0	2.5	2.3
2.	Depth of cut in blackgram (cm)	2.3	2.5	2.0	2.2
3.	Width of cut (cm)	85	85	85	85

4.3.2.2 Draft of implement

During the operation, the draft values were observed for different operators and it was found to be 10.2 kg, 10.5 kg and 11.2 kg for O₁, O₂ and O₃ respectively in case of groundnut field and 10.8 kg, 11.5 kg and 11.8 kg in case of blackgram field. The higher moisture content of soil resulted in a higher draft. It is based on the fact that an increase in soil moisture increases cohesion forces which further increases the requirement of force.

The developed weeder draft was calculated by measuring draft with the help of a load indication system mounted on the handle beam. The highest value of draft required to operate the finger weeder was observed to be 11.8 kg in blackgram field and 11.2 kg in groundnut field. The maximum pushing force for Indian agricultural work ranges from 25 to 30 kg (Gite and Yadav, 1985).

The draft required to operate the weeder was calculated and evaluated. The influence of weeder and operators, as well as their interaction, on draft is explored in the Table 4.4. Draft is a dependent parameter. Hence, when finger disc and tynes were attached individually to the developed finger weeder and operated in each experimental plot displayed different reading of draft in spring type load indicator. The inclination angle was found to be 37 degrees. The mean value of the draft calculated with respect to different operators for each field is also shown in Table 4.5.

Table 4.5 Mean value of draft requirement of different operators

Operators	Draft (kg)	
	Groundnut	Blackgram
O ₁	10.2	10.8
O ₂	10.5	11.5
O ₃	11.2	11.8
Average	10.6	11.3

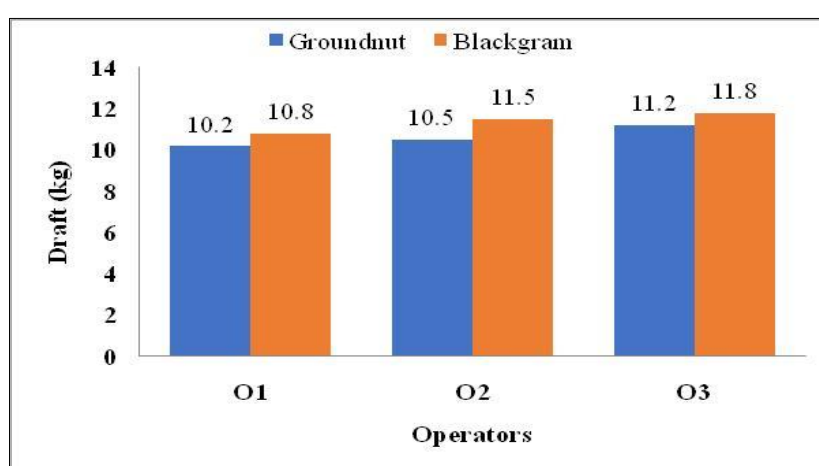

Fig. 4.1 Effect of different operators on draft

Fig. 4.1 shows that the highest draft was applied by operator O₃. The draft requirement indicates how much force was required to operate the weeder. The

maximum draft was found to be 11.8 kg by operator O₃ in blackgram field and 11.2 kg by operator O₃ in groundnut field. The minimum draft applied by the operator was 10.2 kg while working by operator O₁ in groundnut field and 10.8 kg while working by operator O₁ in blackgram field.

4.3.2.3 Operating speed

The finger weeder was operated in the field. The forward speed of the implement was calculated by observing the time travel of 10-meter distance. For measuring the speed of travel, the implement was started well before the first point marker and it was ensured that the speed was uniform throughout the marked space and then the implement was operated at a fixed distance. A stopwatch was used to record the time taken by the implement to travel the marked distance during the operation. Speed was calculated in km/h. During the operation, the speed values were observed for different operators and it was found to be 0.55 km/h, 0.52 km/h and 0.40 km/h for O₁, O₂ and O₃ respectively in case groundnut field as well as blackgram field. The higher draft of the implement resulted in lowest speed. Speed depends on the draft, if the draft will be high then the speed will be reduced

The highest value of speed required to operate the finger weeder was observed to be 0.55 km/h in blackgram field as well as in groundnut field. The speed required to operate the weeder was calculated and evaluated. The influence of weeder and operators, as well as their interaction, on speed is explored in the Table 4.6. The mean value of the speed calculated with respect to different operators for each field is also shown in Table 4.7.

Table 4.6 Operating speed during weeding on blackgram and groundnut field

Sr. No.	Crops	Row length(m)	Time taken(sec)	Speed (km/h)	Average Speed (km/h)
1.	Blackgram	10	65	0.55	0.48
		10	72	0.50	
		10	90	0.40	
2.	Groundnut	10	65	0.55	0.48
		10	72	0.50	
		10	90	0.40	

Table 4.7 Mean values of the speed in relation to the operators in groundnut field and blackgram

Operators	Speed (km/h)	
	Groundnut	Blackgram
O ₁	0.55	0.55
O ₂	0.50	0.50
O ₃	0.40	0.40
Average	0.48	0.48

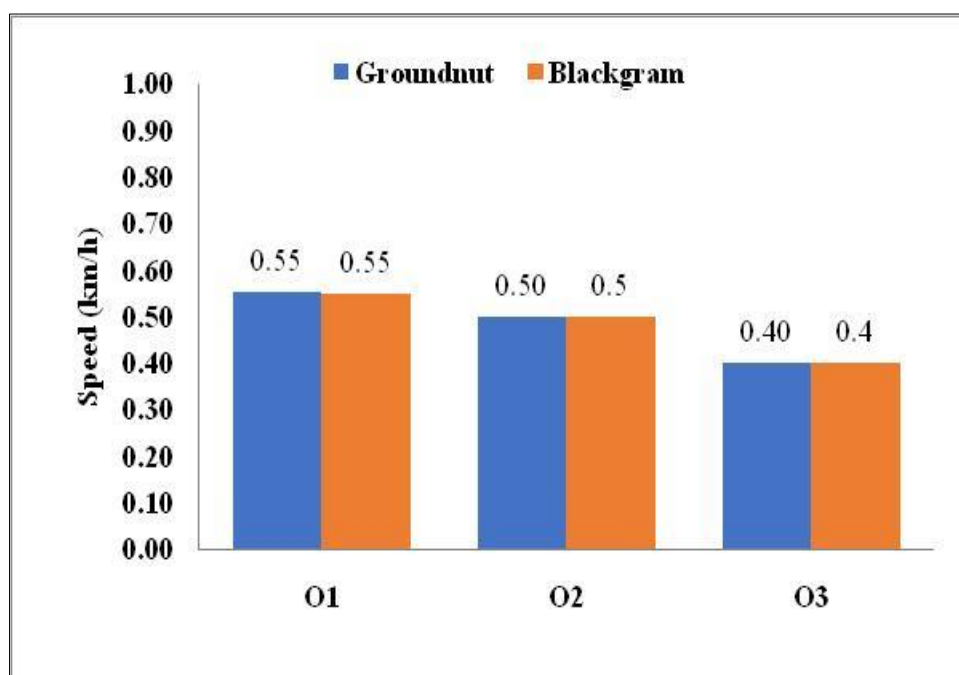

Fig. 4.2 Effect of different operators on speed in groundnut and blackgram field

The result of speed was shown in Fig. 4.2, among all the three operators O₁, O₂ and O₃ the maximum speed was found by operator O₁ which was having 0.55 km/h. The minimum speed was 0.40 km/h found by operator O₃ on the groundnut field as well as blackgram field.

4.3.2.4 Time loss in turning and adjustment

The time loss in turning and adjustment was observed and worked out. It was found to be 8.33 sec and 9.4sec (Average) for the 10-meter length of a row in the field of blackgram and groundnut crops respectively.

4.3.2.5 Plant damage

The number of plants damaged was recorded on the basis of plant population in a unit area before and after the weeding operation. Plant damage is expressed as a percentage. Table 4.8 present the plant damage percent. The plant damage percentages are determined as per the methods described in section 3.5.7.

Table 4.8 Shows the plant damage percent on groundnut and blackgram field

Sr. No.	Crops	No. of plant before weeding per unit area	No. of damaged plant after weeding per unit area	Plant damage (%)
1.	Groundnut	7	0	0.00
		9	1	11.11
		8	1	12.50
2.	Blackgram	25	2	8.00
		20	1	5.00
		22	3	13.60

4.3.2.6 Weeding efficiency

Weeds uprooted by the weeding operation before and after weeding were counted to obtain weeding efficiency. The weeding efficiency was calculated. Mean values of weeding efficiency with respect to different operators are shown in Table 4.9. Operator O₁ had the highest weeding efficiency (82.22 %), while operator O₂ had the lowest (76.92 %) in the groundnut field. In the blackgram field, operator O₃ had the highest effective field efficiency of 78.66 %, while operator O₁ had the lowest field efficiency of 70.58 %. The average value of weeding efficiency is depicted in Table 4.9.

Table 4.9 Mean value of weeding efficiency in groundnut and blackgram field

Operators	Weeding efficiency (%)	
	Groundnut	Blackgram
O ₁	82.22	70.58
O ₂	76.92	72.83
O ₃	81.25	78.66
Average	80.13	74.02

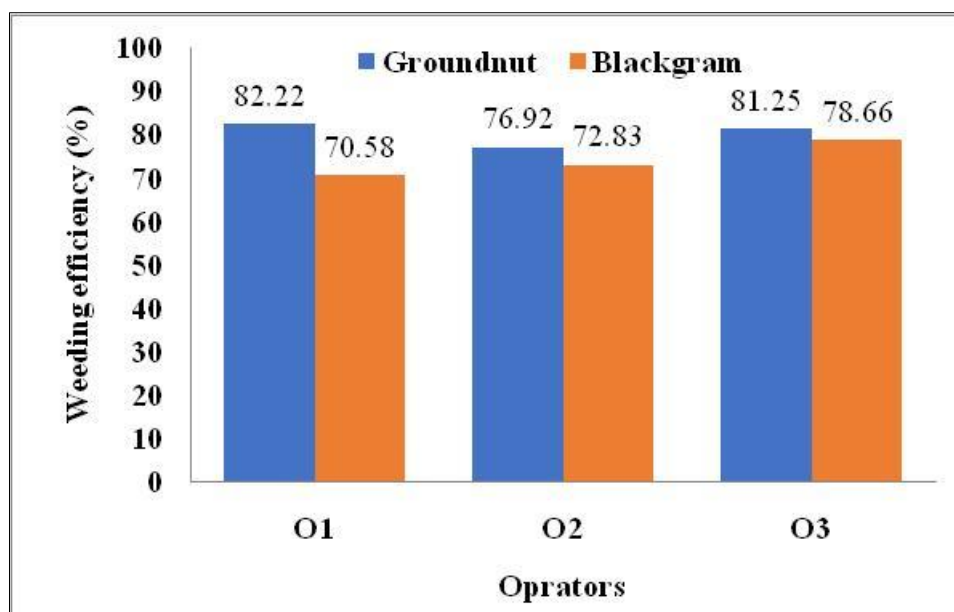

Fig. 4.3 Effect of different operators on weeding efficiency in groundnut and blackgram field

A graphical representation of weeding efficiency is shown in Fig. 4.3. It shows that the weeding efficiency was found to be highest for operator O₁ followed by O₂ and O₃. The maximum value of weeding efficiency was 82.22 % while working with Operator O₁. The minimum value of weeding efficiency was 76.92 % while working with Operator O₂ in the groundnut field.

It is also shown that the weeding efficiency was found to be highest for operator O₃ followed by O₁ and O₂. The maximum value of weeding efficiency was 78.66 % while working with Operator O₃. The minimum value of weeding efficiency was 70.58 % while working with Operator O₁ in the blackgram field.

4.4 POWER REQUIREMENT AND EFFICIENCY

The power requirement, field capacities and field efficiencies for each crop were calculated with the help of formula given in section 3.6.

(a) Power requirement

The power required to operate the weeder was calculated by taking into consideration draft and the speed of the operation. The power required by the operator was calculated and evaluated. During the operation, the power requirement were observed for different operators and it was found to be 0.020 hp, 0.019 hp and 0.016 hp for O₁, O₂ and O₃ respectively in case groundnut field and 0.022 hp, 0.021 hp and

0.17 hp in blackgram field. The higher power of the implement resulted in lowest draft and highest speed because power depends on the speed and draft.

The highest value of power required to operate the finger weeder was observed to be 0.020 hp in case of groundnut field and 0.022 hp in blackgram field. The power required to operate the weeder was calculated and evaluated. The influence of weeder and operators, as well as their interaction, on power is explored in the Table 4.9. The mean value of the power calculated with respect to different operators for each field is also shown in Table 4.10.

Table 4.10 Mean value of power calculated with respect to groundnut and blackgram field

Operators	Power required (hp)	
	Groundnut	Blackgram
O ₁	0.020	0.022
O ₂	0.019	0.021
O ₃	0.016	0.017
Average	0.018	0.020

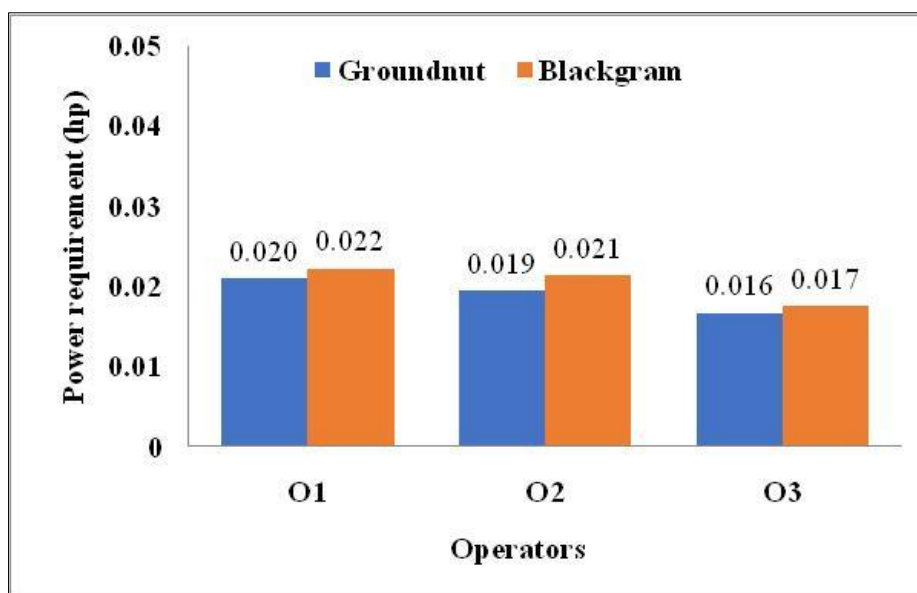

Fig. 4.4 Effect of operators on power requirement in groundnut and blackgram field

Graphical representation of power requirement is shown in Fig.4.4, it shows that the power required for operation was highest by operator O₁ followed by O₂ and

O₃. The maximum value of power required was found to be 0.020 hp while working with operator O₁ whereas the least value was found to be 0.016 hp while working with operator O₃ on groundnut field. It is also shown that the power required for operation was highest by operator O₁ followed by O₂ and O₃. The maximum value of power required was found to be 0.022 hp while working with operator O₁ whereas the least value was found to be 0.017 hp while working with operator O₃ on blackgram field.

(b) Theoretical field capacity

The theoretical field capacity of the developed finger weeder was evaluated. The values of theoretical field capacity with respect to different operators are shown in Table 4.10.

During the operation, the theoretical field capacity were observed for different operators and it was found to be 0.047 ha/h, 0.043 ha/h and 0.034 ha/h for O₁, O₂ and O₃ respectively in case groundnut field as well as blackgram field. The higher theoretical field capacity of the implement resulted in highest speed.

The highest value of theoretical field capacity to operate the finger weeder was observed to be 0.047 ha/h in case of groundnut field as well as blackgram field. The theoretical field capacity to operate the weeder was calculated and evaluated. The influence of weeder and operators, as well as their interaction, on theoretical field capacity is explored in the Table 4.11. The mean value of the speed calculated with respect to different operators for each field is also shown in Table 4.10.

Table 4.11 Mean value of theoretical field capacity groundnut and blackgram field

Operators	Theoretical field capacity ha/h	
	Groundnut	Blackgram
O ₁	0.047	0.047
O ₂	0.043	0.043
O ₃	0.034	0.034
Average	0.041	0.041

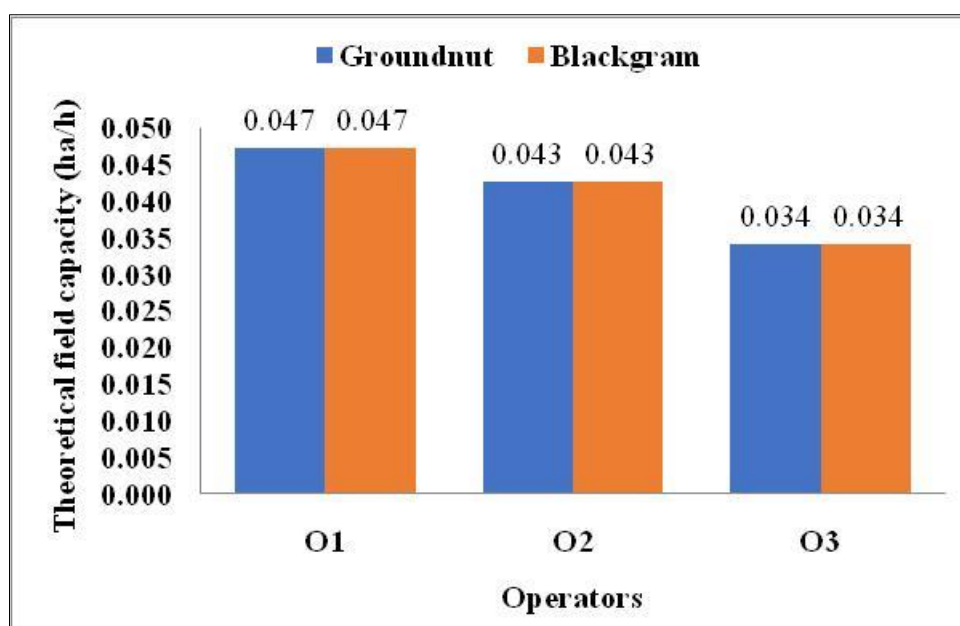

Fig. 4.5 Effect of operators on theoretical field capacity in groundnut and blackgram field

Graphical representation of theoretical field capacity is shown in Fig. 4.5. The theoretical field capacity was found highest for operator O₁ (0.047 ha/h) followed by operator O₃ and operator O₂ on the groundnut field as well as blackgram field.

(c) Effective field capacity

The effective field capacity of the weeder was calculated on the basis of the actual area covered by the weeder.

During the operation, the effective field capacity were observed for different operators and it was found to be 0.038 ha/h, 0.036 ha/h and 0.033 ha/h for O₁, O₂ and O₃ respectively in case groundnut field and 0.037 ha/h, 0.035 ha/h and 0.031 ha/h in blackgram field. Effective field capacity is less than the theoretical field capacity because we consider time losses in effective field capacity. The higher effective field capacity of the implement resulted in lowest draft and highest speed because it depends upon the area covered and time travel.

The highest value of effective field capacity to operate the finger weeder was observed to be 0.038 ha/h in case of groundnut field and 0.037 ha/h in blackgram field. The effective field capacity to operate the weeder was calculated and evaluated. The influence of weeder and operators, as well as their interaction, on effective field

capacity is explored in the Table 4.12. The mean value of the speed calculated with respect to different operators for each field is also shown in Table 4.11.

Table 4.12 Mean value of effective field capacity on groundnut and blackgram field

Operators	Effective field capacity ha/h	
	Groundnut	Blackgram
O ₁	0.038	0.037
O ₂	0.036	0.035
O ₃	0.033	0.031
Average	0.036	0.035

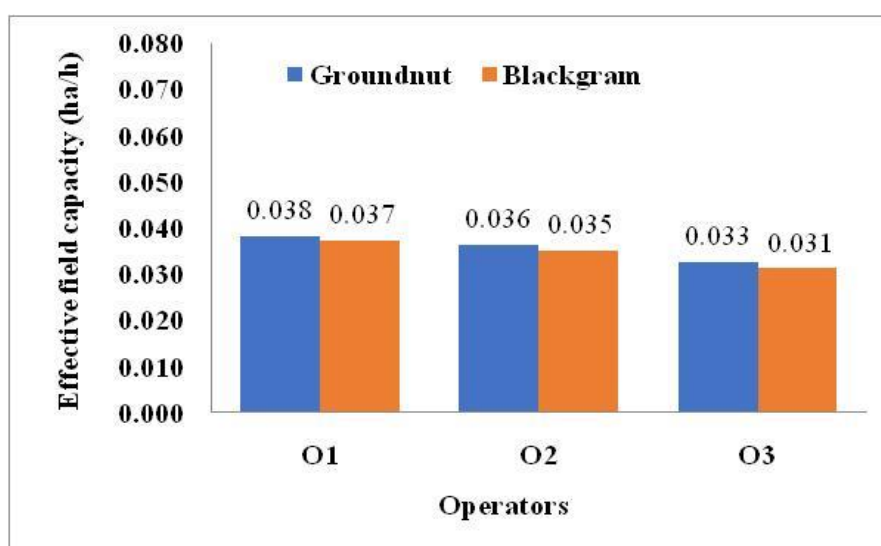

Fig. 4.6 Effect of operators on effective field capacity in groundnut and blackgram field

Graphical representation of effective field capacity is shown in Fig. 4.6, it is shown that the effective field capacity for the operation was highest by operator O₁ followed by O₂ and O₃. The maximum value of effective field capacity was found to be 0.038 ha/h while working with operator O₁ whereas the least value was found to be 0.033 ha/h while working with operator O₃ on groundnut field.

It is shown that the effective field capacity for the operation was highest by operator O₁ followed by O₂ and O₃. The maximum value of effective field capacity was found to be 0.037 ha/h while working with operator whereas the least value was found 0.031 ha/h while working with operator O₃ on blackgram field.

(d) Field efficiency

The ratio of effective field capacity and theoretical field capacity expressed in percentage is known as field efficiency.

During the operation, the field efficiency were observed for different operators and it was found to be 81.25 %, 85.71%, 95.74% for O₁, O₂ and O₃ respectively in case groundnut field and 79.26 %, 82,75 % and 91.83 % in blackgram field.

The highest value of field efficiency to operate the finger weeder was observed to be 95.74 % in case of groundnut field and 91.83 % in blackgram field. The field efficiency to operate the weeder was calculated. The influence of weeder and operators, on field efficiency is explored in the Table 4.13. The mean value of the speed calculated with respect to different operators for each field is also shown in Table 4.13.

Table 4.13 Mean value of field efficiency on groundnut and blackgram field

Operators	Field efficiency (%)	
	Groundnut	Blackgram
O ₁	81.25	79.26
O ₂	85.71	82.75
O ₃	95.74	91.83
Average	87.5	84.62

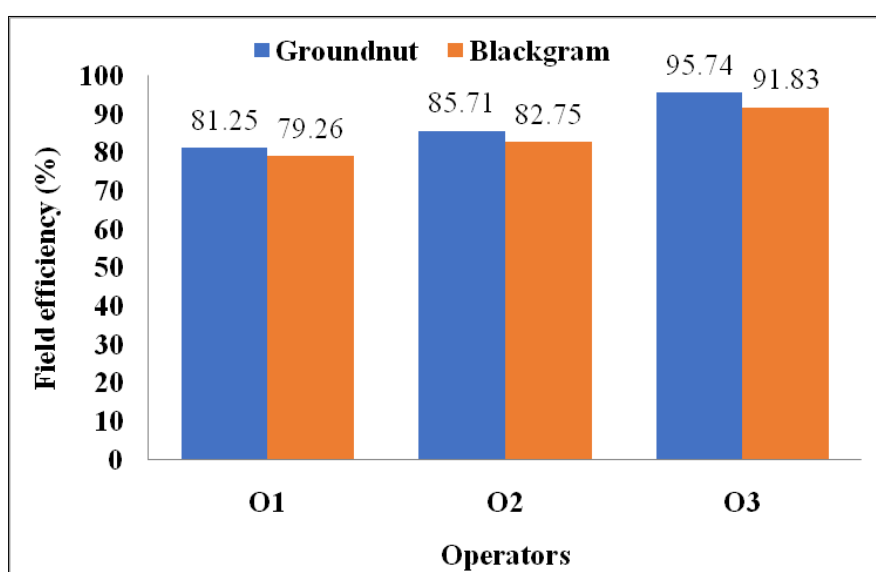

Fig. 4.7 Effect of operators on field efficiency in groundnut and blackgram field

A graphical representation of field efficiency is shown in Fig. 4.7. It is shown that the field efficiency was found to be highest for operator O₃ followed by O₂ and O₁. The maximum value of field efficiency was 95.74 % while working with operator O₃. The minimum value of field efficiency was found to be 81.25 % while working with operator O₁ on the groundnut field. The maximum value of field efficiency was 91.83 % while working with operator O₃ and minimum value of field efficiency was found to be 79.26 % while working with operator O₁ on the blackgram field.

4.5 ERGONOMIC EVALUATION

The ergonomic evaluation was done by physiological and subjective evaluation of each parameter. Under physiological evaluation, determination of heart rate, oxygen consumption rate and energy expenditure rate was considered.

4.5.1 Physiological Evaluation

(a) Heart rate

Before and after each experiment, the heart rate was measured. The operator's heart rate was measured using the iCare oxygen monitor app on the mobile phone. The heart rate is measured by placing the index finger on the back camera and the thumb on the device's screen until the reading shows, then pressing it until the test is finished. It was found from Table 4.14 that operator O₂ was having the highest heart rate 91 bpm whereas operator O₁ with the least heart rate 88 bpm after work on the groundnut field. In the blackgram field operator, O₃ had the highest heart rate 93 bpm, while operator O₁ had the lowest heart rate 89 bpm.

Table 4.14 Mean value of heart rate before and after work on groundnut and blackgram field

Operators	Heart rate bpm before work (bpm)		Heart rate bpm after work (bpm)	
	Groundnut	Blackgram	Groundnut	Blackgram
O ₁	71	72	88	89
O ₂	73	75	91	92
O ₃	75	77	90	93
Avgerage	73.00	74.66	89.66	91.33

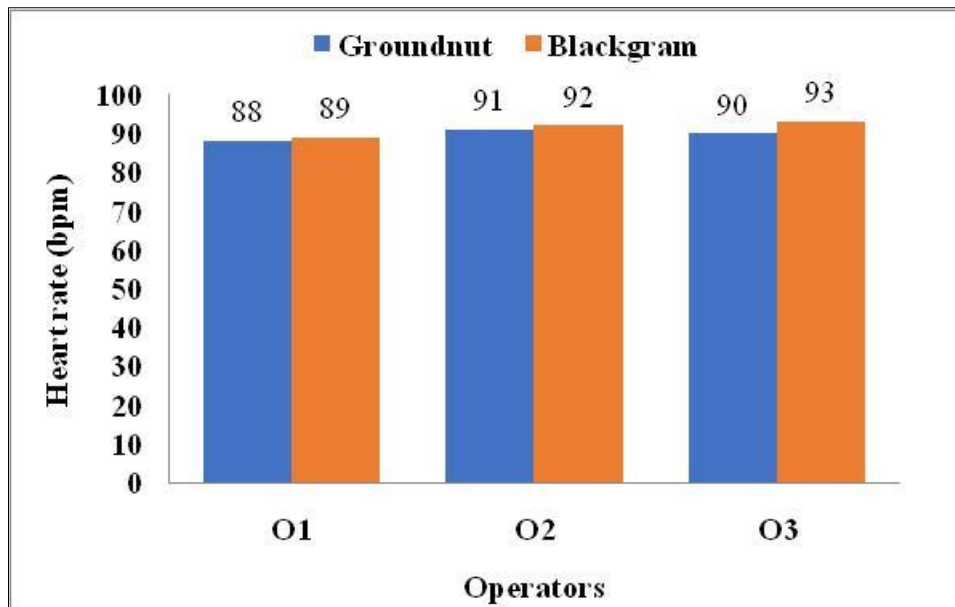

Fig. 4.8 Effect of different operators on heart rate in groundnut and blackgram field after work

Graphical representation of the heart rate of operators is shown in Fig. 4.8, it is shown that the heart rate was found highest for operator O₂. The maximum value of heart rate was 91 bpm while working operator O₂. The minimum value of heart rate was 88 bpm while working with operator on the groundnut field. It is also shown that the heart rate was found highest for operator O₃. The maximum value of heart rate was 93 bpm while working with operator O₃ on blackgram field. The minimum value of heart rate was 89 bpm while working operator O₁ on the blackgram field.

(b) Oxygen consumption rate

The oxygen consumption rate is defined as the amount of oxygen consumed by the tissues of the body, usually measured as the oxygen uptake in the lung. It increases with an increase in metabolic rate. It was measured in l/min or ml/min (Anon., 2016). It was calculated by the following equation given in section 3.7.1 (Singh, 2012).

From Table 4.14, it was found that operator O₂ was having the highest oxygen consumption rate (0.35 l/min) whereas the operator O₁ and O₃ with the least oxygen consumption rate (0.32 and 0.34 l/min) in the groundnut field. From Table 4.15, it was found that operator O₃ had the highest oxygen consumption rate (0.38) whereas operators O₁ and O₂ with the least oxygen consumption rate (0.33 and 0.36 l/min) in

the blackgram field. Oxygen consumption rate depends on the heart rate, if higher the heart rate then higher the oxygen consumption rate.

Table 4.15 Mean value of oxygen consumption rate on groundnut and blackgram field

Operators	Oxygen consumed l/min	
	Groundnut	Blackgram
O ₁	0.32	0.33
O ₂	0.35	0.36
O ₃	0.34	0.38
Avgerage	0.34	0.36

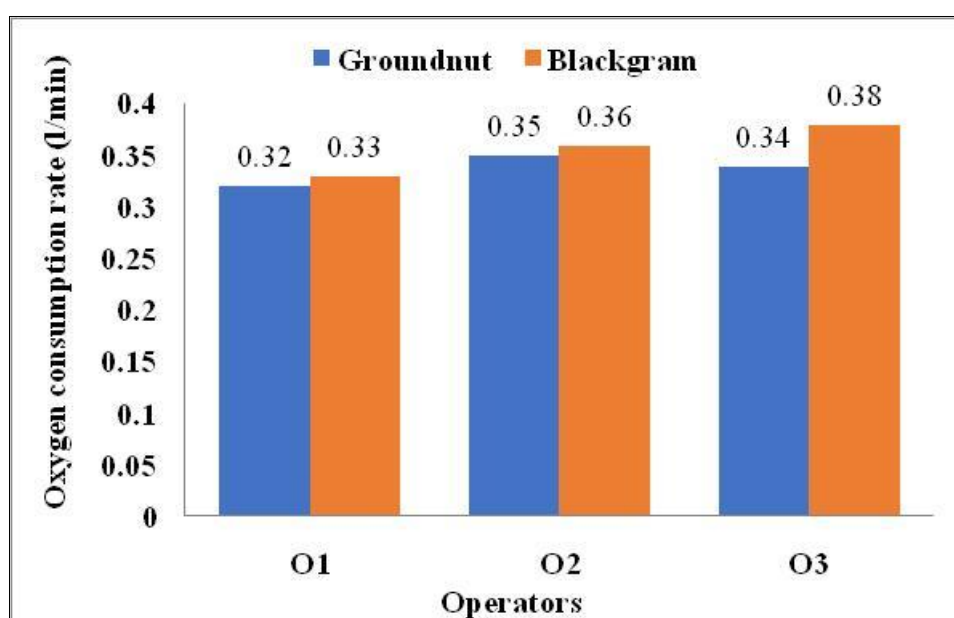

Fig. 4.9 Effect of different operators on oxygen consumption rate in groundnut and blackgram field

A graphical representation of the oxygen consumption rate of operators is shown in Fig. 4.9, it is shown that the oxygen consumption rate was found highest for operator O₂. The maximum value of oxygen consumption rate was found at 0.357 l/min while working operator O₂. The minimum value of oxygen consumption rate was found 0.323 l/min while working operator O₁ on the groundnut field. Fig 4.9, it is shown that the oxygen consumption rate was found highest for operator O₃. The maximum value of oxygen consumption rate was 0.380 l/min while working operator

O₃. The minimum value of oxygen consumption rate was 0.334 l/min while working operator O₁ on the blackgram field.

(c) Energy expenditure rate

The energy expenditure was calculated by multiplying the oxygen used by the subject during the trial period by the calorific value of 20.93 KJ/l of oxygen (Nag and Dutta, 1980).

It was presented in Table 4.16, that operator O₂ had the highest energy expenditure rate of 7.48 KJ/min whereas operator O₁ had the lowest energy expenditure rate of 6.76 KJ/min on the groundnut field. In the blackgram field operator, O₃ had the highest energy expenditure rate 7.95 KJ/min, while operator O₁ had the lowest energy expenditure rate 7.00 KJ/min.

Table 4.16 Mean value of energy expenditure rate on groundnut and blackgram field

Operators	Energy expenditure rate KJ/min.	
	Groundnut	Blackgram
O ₁	6.76	7.00
O ₂	7.48	7.71
O ₃	7.24	7.95
Avgerage	7.16	7.55

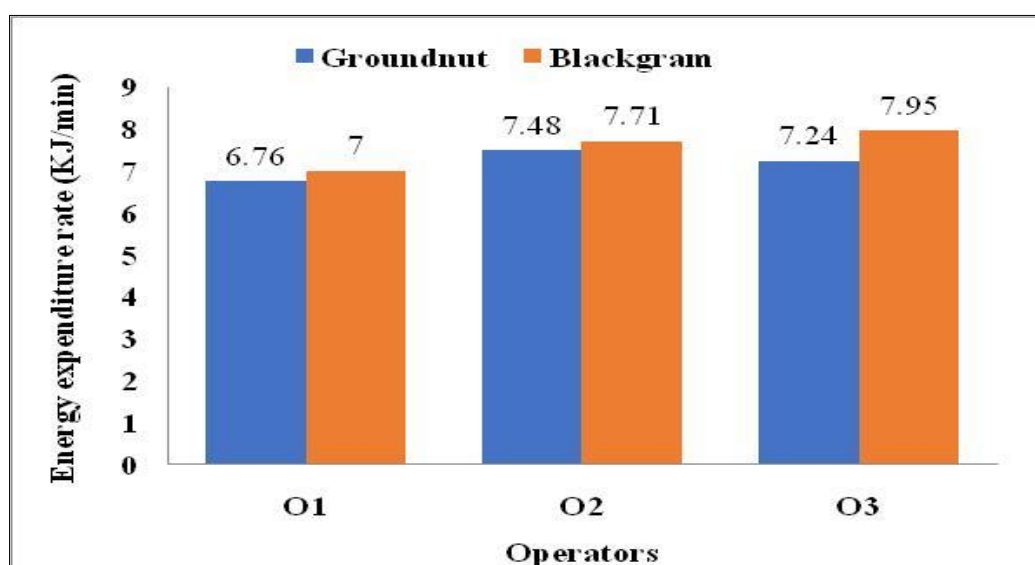

Fig. 4.10 Effect of different operators on energy expenditure rate in groundnut and blackgram field

A graphical representation of the energy expenditure rate of operators is shown in Fig. 4.10, it is shown that the energy expenditure rate was found highest for operator O₂. The maximum value of energy expenditure rate was 7.48 KJ/min while working operator O₂. The minimum value of energy expenditure rate was 6.76 KJ/min while working operator O₁ on the groundnut field. Fig 4.10, it is also shown that the energy expenditure rate was found highest for operator O₃. The maximum value of energy expenditure rate was 7.95 KJ/min while working operator O₃. The minimum value of energy expenditure rate was 7.00 KJ/min while working operator O₁ on the blackgram field.

4.5.2 Anthropometry Data

The design of an efficient workplace configuration should be done by considering the anthropometric data for the user's population. The location of the hand and foot-operated controls should be within easy reach of the operators. This data will help to determine various parameters that affect the operator's physiological aspects. The details of the basic anthropometric data are given in Table 3.7. The BMI of operator O₁, O₂ and O₃ was found to be 17.80 kg/m², 22.77 kg/m² and 21.79 kg/m² respectively. The calculation regarding the BMI index is given in Appendix E.

4.6 ECONOMICAL CONSIDERATIONS

4.6.1 Manual Weeding

Average man-hours required for manual weeding per hectare in the case of Blackgram and groundnut were observed to be 21.36 h/ha and 17.29 h/ha with the respective row-to-row spacing of 45 cm. The cost of manual weeding operation per hectare was worked out as Rs. 2142.85 and 2678.57 for the crops blackgram and groundnut respectively.

4.6.2 Mechanical Weeding

The weeding by finger weeder was aimed to reduce the labour cost of manual weeding. With the operation of the developed device, it is possible to reduce the labour cost in weeding operations.

4.6.2.1 Cost of operation

The cost of operation was calculated for weeding by finger weeder considering the prevailing rates of operators and labour etc. The cost of operation was calculated from

the summation of fixed cost and variable cost. The total cost of operation (Rs/ha) varies with that of the effective field capacity. The calculation and data both are given in Appendix-C. The cost of operation for weeding was calculated with respect to different operators is shown in Table 4.17. In the field, a manual push-type weeder was used. The higher effective field capacity of the implement resulted in lowest cost of operation because its depend upon the area covered and time travel.

During the operation, the cost of operation were observed for different operators and it was found to be 1031.73 Rs/ha, 1083.32 Rs/ha and 1212.29 Rs/ha for O₁, O₂ and O₃ respectively in case groundnut field and 1057.53 Rs/ha, 1122.01 Rs/ha and 1263.87 Rs/ha in blackgram field. The highest value of cost of operation to operate the finger weeder was observed to be 1212.29 Rs/ha in case of groundnut field and 1263 Rs/ha in blackgram field.

Table 4.17 Mean value of calculated cost of operation on groundnut and blackgram field

Parameters	Cost of operation (Rs/ha)	
	Groundnut	Blackgram
O ₁	1031.73	1057.53
O ₂	1083.32	1122.01
O ₃	1212.29	1263.87
Average	1109.11	1147.80

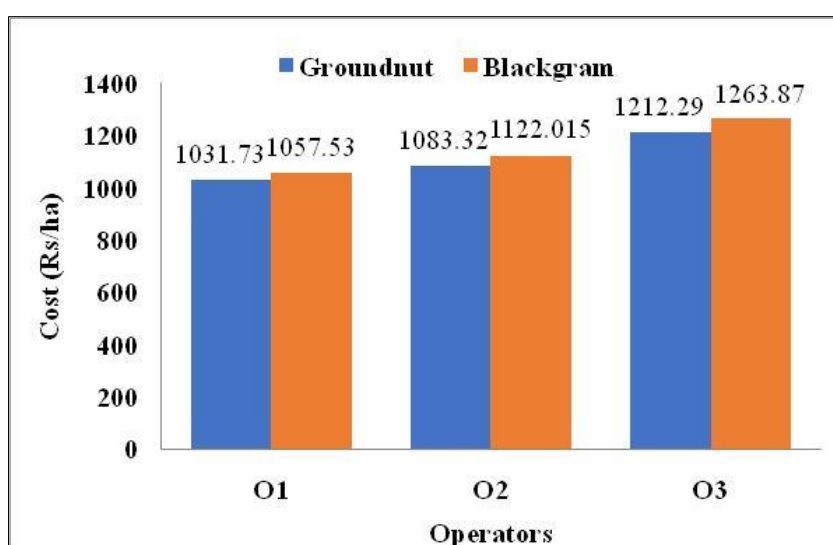

Fig. 4.11 Effect of different operators on cost of operation in groundnut and blackgram field

A graphical representation of the cost of operation is shown in Fig. 4.11. Operator O₃ had the highest cost of operation of 1212.29 Rs/ha and operator O₁ had the lowest cost of operation of 1031.73 Rs/ha in groundnut field. The minimum value of cost of operation was found to be 1057.53 Rs/ha while working with operator O₁ and maximum value of cost of operation was found 1263.87 Rs/ha while working with operator O₃ in the blackgram field.

4.6.3 Economical Comparison of Mechanical Weeding with Manual Weeding

The operational comparison of mechanical weeding with manual weeding method has been discussed in detail in terms of requirements and advantages of man-hours, energy and cost, are presented in Fig. 4.12, 4.13 and 4.14.

(a) Time

The value of operational time per hectare of finger weeder and hand weeding were calculated using the area of the experimental plot and the time taken for the operation. Calculation of operational time per hectare of finger weeder and hand weeding is given in Appendix-F. The values of operational time per hectare of finger weeder and hand weeding are given in Table 4.18. During the operation, the operational time was observed and it was found to be 28.10 man-h/ha in groundnut field and 29.08 man-h/ha in blackgram field by the finger weeder. The energy consumption by hand weeding was observed and it was found to be 285.71 man-h/ha in groundnut field and 228 man-h/ha in blackgram field. The value of operational time with respect to finger weeder and hand weeding for each field is shown in Table 4.18.

Table 4.18 Value of operational time of finger weeder and hand weeding

Parameters	Finger weeder		Hand weeding	
	Groundnut crop	Blackgram crop	Groundnut crop	Blackgram crop
Operational time (man-h/ha)	28.10	29.08	285.71	228.57

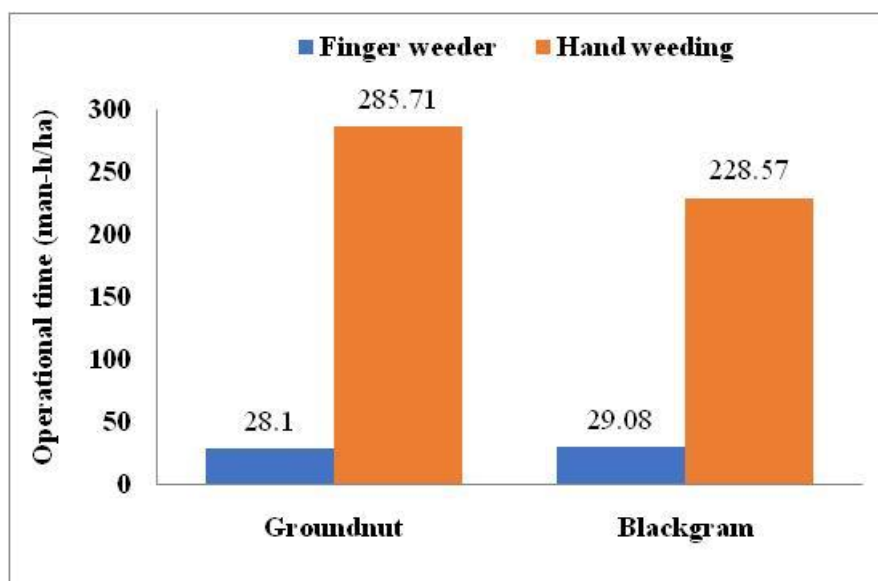

Fig. 4.12 Effect of operational time of finger weeder and hand weeding

A graphical representation of operational time is shown in Fig. 4.12. It is shown that the operational time was found to be maximum by hand weeding 285.71 man-h/ha in groundnut field. The minimum value operational time was 28.10 man-h/ha while working with finger weeder. The time taken was found highest for hand weeding followed by finger weeder, time taken is more in groundnut field due to the high weed density.

(b) Energy Consumption

The value of energy consumption of finger weeder was determined using operational time, the number of labours required for operation and the coefficient of human energy consumption. Similarly, values of energy consumption of hand weeding were determined considering operational time, number of labours required for operation and coefficient of human energy consumption.

The finger weeder is operated manually in the field. The human energy utilized in weeding operation in the field for weeder was evaluated. Manual energy expended or energy consumption is equal to the product of a number of labours used in the operation and the total operating time taken by the operator with a coefficient of human energy consumption. During the operation, the energy consumption were observed and it was found to be 55.07 MJ/ha in groundnut field and 58.40 MJ/ha in blackgram field by the finger weeder. The energy consumption by hand weeding were observed and it was found to be 559.99 MJ/ha in groundnut field and 446.88 MJ/ha in

blackgram field. The mean value of the energy consumption for finger weeder and hand weeding for the blackgram and groundnut field is shown in Table 4.19. Calculations of energy consumption of mechanical and hand weeding are given in Appendix-G. The values of energy consumption of finger weeder and hand weeding are given in table 4.19.

Table 4.19 Mean value of field efficiency on groundnut and blackgram field

Parameters	Energy consumption (MJ/ha)	
	Groundnut	Blackgram
Finger weeder	55.07	58.40
Hand weeding	559.99	446.88

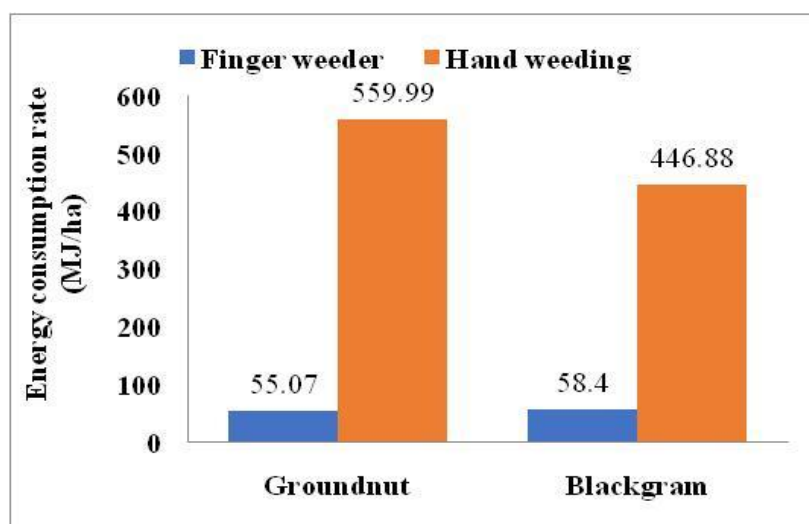

Fig. 4.13 Energy consumption in groundnut and blackgram field using finger weeder and hand weeding

A graphical representation of energy consumption is shown in Fig. 4.13 it is shown that the energy consumption was found to be maximum by hand weeding followed by finger weeder because its depend upon the number of labour required to area covered in time and hand weeding required more time for weeding then mechanical weeding, its also increase the drudgery and fatigue.

(c) Cost of Operation

The value of the cost of operation of the finger weeder was determined using fixed cost, the variable cost of operation and effective field capacity. Similarly, the value of the cost of operation of hand weeding was also determined. Calculations of

cost of operation of mechanical and hand weeding are given in appendix-C and appendix-D. The values of the cost of operation of finger weeder and hand weeding are given in Table 4.20. During the operation, cost of operation were observed and it was found to be 1109.11 Rs/ha in groundnut field and 1147.80 Rs/ha in blackgram field by the finger weeder. The cost of operation by hand weeding were observed and it was found to be 2678.57 Rs/ha in groundnut field and 2142.85 Rs/ha in blackgram field.

Table 4.20 Values of cost of operation of finger weeder and hand weeding

Parameter	Finger weeder		Hand weeding	
	Groundnut	Blackgram	Groundnut	Blackgram
Cost of operation (Rs/ha)	1109.11	1147.80	2678.57	2142.85

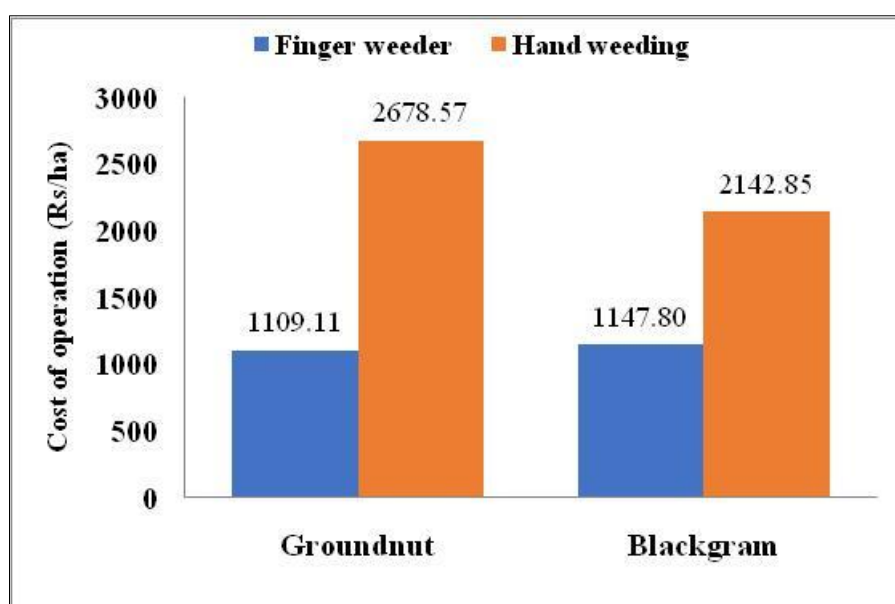

Fig. 4.14 Values of cost of operation of finger weeder and hand weeding

A graphical representation of the cost of operation is shown in Fig. 4.14. The cost of operation was found highest for hand weeding followed by finger weeder. The maximum value of the cost of operation was 2678.57 Rs/ha for hand weeding and 1147.80 Rs/ha for finger weeder. Cost of hand weeding is more because its required the maximum number of labour for weeding as compared to mechanical weeding.

CHAPTER - V

SUMMARY AND CONCLUSIONS

5.1 SUMMARY

The weeding operation was carried out to maintain the proper plant growth per hectare, if done manually as the present practices, required a high quantum of human energy. This results in high cost of production. It is required to reduce the high cost of human labour by introducing some mechanized way of weeding due to more weed density, plants do not grow better and ultimately reduce the crop yield. Therefore, weeding is necessary to maintain crop yield by manually/mechanically performed weeding operation at earlier growth stage of the row crops. Such crops require weeding within 15 to 20 days after their emergence.

Keeping in view the requirement of mechanized way of weeding of crops and functional parameters viz. inter row spacing of crop, required intra row spacing: root depth, plant canopy and plant height at the time of weeding soil characteristics as well as engineering aspects viz. speed of operation, depth of cut, width of cut, push, soil resistance and power availability, a weeding device was designed and developed at the Department of Farm Machinery and Power, College of Agricultural Engineering and Technology, JAU, Junagadh, Its construction includes the main components such as handle, frame, tynes, finger disc and ground wheels.

The evaluation of working performance of the developed finger weeder in the field leads to the following conclusions.

1. The design of main components such as handle, frame, finger disc, tynes and ground wheels observed dimensionally suitable to operate manually. The attachment and detachment on the implement was observed simple and easy.
2. The average depth of cut by tynes and finger disc was observed as 2.3 cm and 2.2 cm for the crop Groundnut and Black gram. The width of cut was 85 cm for all the crops under study.
3. The highest field capacities were observed as 0.047 and 0.038 ha/h with the field efficiencies 95.74 % respectively.
4. The highest draft requirement for the weeding operation with the designed device was found 11.8 kg.

5. The highest power required was found in operation as 0.022 hp.
6. The highest plant damage in terms of buried plants and cutting of plant leaves was found 13.60 %
7. The highest weeding efficiencies were found 82.22 %.
8. The comparative advantages of mechanized weeding over manual weeding in terms of percentage reduction in man hours of 28.10, 29.08 and 285.71, 228.57 man-hr/ha, energy of 49.74, 51.66 and 559.99, 446.88 MJ/ha and cost of operation were found as 1109.11, 1147.80 and 2678.57, 2142.88 Rs/ha respectively in case of groundnut and blackgram crops.
9. The highest heart rate, oxygen consumption rate and energy expenditure rate was found 93 bpm, 0.38 l/min and 7.95 KJ/min.
10. The developed unit performed the functional requirement satisfactorily. It can be easily attached or detached. The draft requirement in operation is within the limit. The damage to the plants is negligible. The field capacity of operation is quite satisfactory. The device proved quite useful to reduce the cost of production of crops by way of partial mechanized weeding operation.
11. Looking to the above conclusions, it can be recommended that developed push type manual dual wheel weeder can successfully be used for weeding.

BIBLIOGRAPHY

- Agrawal, K. N., Tiwari, P. S., Gite, L. P. and Bhushana babu, V. (2010). Isometric push/pull strength of agricultural workers of central India. *Agricultural Engineering International*. **12(1)**: 115-124.
- Anderson, W. P. (1977). *Weed science principles*. Second edition. West publishing company, USA, pp. 65-122.
- Anonymous (2020). Annual Report. Department of Agriculture, Cooperation & Farmers Welfare, Ministry of Agriculture & Farmers Welfare, Government of India, pp. 1-3. Available at [https://agricoop.nic.in/sites/default/files/ACFW %20English%20%20Annual%20Report%202019-20.pdf](https://agricoop.nic.in/sites/default/files/ACFW%20English%20%20Annual%20Report%202019-20.pdf) accessed on 25th November 2021.
- Anonymous. (2016) Heart Rate. Wikipedia: the free encyclopedia. [http://en.wikipedia.org/wiki/Heart rate](http://en.wikipedia.org/wiki/Heart_rate). Accessed on 14th December 2021.
- Anonymous. (2017). Crop-weed Association, Crop-weed competition and allelopathy. eagri.tnau.ac.in/eagri50/AGRO304/pdf/lec05.pdf. Accessed on 18th December 2021.
- Biswas, H. S. (1984). Weed control technique, CIAE Technical Bulletin No. CIAE / 84 / 46.
- Biswas, H. S. (1990). Soil tool interaction for mechanical control of weed in black soils. Unpublished Ph. D. Thesis, Indian Institute of Technology, Kharagpur.
- Biswas, H. S., Rajput, D. S. and Devanani, R. S. (1989). Animal drawn weeder for weed control in India, A resource book of the animal traction network for eastern and south Africa, Technical center for Agricultural and Rural Cooperation, Wageningen (Netherlands).
- Biswas, H. S., Rajput, D. S. and Devnani, R. S. (2000). Animal power for weed control. Starkey, P. and Simalenga, T. (eds): A resource book of the Animal Traction Network for Eastern and Southern Africa (ATNESA). Technical Centre for Agricultural and Rural Cooperation (CTA), Wageningen, The Netherlands.

- Bleeker, P., Van der weide, R., Kurstjens, D. and Cloutier, D. C. (2002). Experiences and experiments with new intra-row weeders. In *Proceedings of the 5th EWRS Workshop on Physical and Cultural Weed Control*. 97-100.
- Bogdan, I., Gus, P., Rusu, T., Pop, A., Vaju, A. and Morar, P. (2006). Research concerning weed control in maize crop. University of Agricultural Science and Veterinary Medicine of Cluj-Napoca. *ErcetariAgronomice in Moldova, Anul XXXX*, **1**:129.
- Chapanis, A. (1985). Some reflection on progress. *Proceedings of the Human Factor Society Annual Meeting*. **29**: 1-8.
- Chaudhary, V., Gangwar, B. and Pandey, D. (2006). Auditing of energy use and output of different cropping systems in India. *Agricultural Engineering International, The CIGR EJournal*, manuscript EE05 001 (VII). pp. 3.
- De Looze, M. P., Van Greuningen, K., Rebel, J., Kingma, I. andKuijjer, P. P. F. M. (2000). Forcedirection and physical load dynamic pushing and pulling.*Ergonomics*.**43(3)**: 377-390.
- Dighe, V. D. (2003). Development and performance evaluation of manually operated improved wheel hoe. Unpublished M. Tech. thesis, MPKV, Rahuri, India.
- Dixit, J. and Syed, I. (2008). Field evaluation of weeder for rain-fed crops in Kashmir valley. *Agricultural Mechanization in Asia, Africa & Latin America*. **39(1)**: 53.
- Gite, L. P. (1993). Ergonomics in India agriculture a review, paper presented in the international workshop on human and draught animal-powered crop protection held at Harare on 19-22 January.
- Gite, L. P. and Yadav, B. G. (1985). Ergonomic consideration in the design of mechanical weeders. *Proceedings on Design Course of Agricultural machines*, CIAE, Bhopal, India.
- Gite, L. P. and Yadav, B. G. (1990). Optimum handle height for push and pull type manually operated dry land weeder. *Ergonomics*.**33**: 1487-1494.
- Gite, L. P. and Yadav, B. G. (2007). Optimum handle height for push and pull type manually operated dry land weeder. *Ergonomics*.**33**: 1487-1494.

- Gite, L. P., Majumder, J., Mehta, C. R. and Khadatkar, A. (2009). Anthropometric and strength data of Indian agricultural workers for farm equipment design. CIAE. Bhopal, India.
- Goel, A. K., Behera, D., Behera, S. K., Mohanty B. K. and (2008). Development and ergonomic evaluation of manually operated weeder for dry land crops. *Agricultural Engineering International: CIGR Journal*.
- Guruswami (1997). Proceeding of the first workshop on design methodology of agricultural machinery CIAE, Bhopal pp.30
- Haribabu, B., Prakash, R. J., Kumar, D. A. and Prasad, P. (2015). Ergonomic evaluation of manual and power operated weeders in dry land condition. *International Journal of Agricultural Engineering*. **8(2)**: 169-174.
- Hasalkar, S., Renuka., B., Rajeshwari, S. and Nutan, B. (2004). Assessment of workload of weeding activity in crop production through heart rate. *Journal of Human Ecology*. **14(3)**: 165-167.
- International Journal for Modern Trends in Science and Technology*. **3**: 27-33.
- Kamal, A. R. and Babatunde, O. O. (1999). Development of push-type oscillatory power Weeder. *Journal of Agricultural Engineering and Technology*. **7**: 23-28.
- Kamboj, P., Khurana, R. and Dixit, A. (2012). Farm machinery services provided by selected cooperative societies. *Agricultural Engineering International: CIGR Journal*, **14(4)**:123.
- Kepner, R. A., Bainer, R., and Barger, E. L. (1982). Principle of Farm Machinery 3rd edition Westport, CT: AVI Publishing Company.
- Kepner, R.A., Bainer, R. and Barger, E. L. (1978). Principles of farm machinery. 3rd edition CBS Publicatios and Distributors, New Delhi.
- Kepner, R.A., Bainer, R. and Barger, E.L. (2017). Principles of farm machinery e book. 3rd edition, CBS Publications and Distributors, New Delhi. <https://content.kopykitab.com/ebooks/2017/10/11971/sample/sample11971.pdf>, accessed on 3rd December 2021.
- Konda Babu, P. and Govinda Rao, S. (2017). Manually operated dry land weeder.

- Malavia, D. D., Madhwadia, M. M., Sukhadia, N. M., Sagarika, B. K., Ramani, B. B. and Asodaria, K. B. (1998). Bulletin on weed research in Gujarat, Department of Agronomy, GAU. 3-4.
- Milberg, P. and Hallgren, E. (2004). Yield loss due to weeds in cereals and its large scale variability in Sweden. *Field Crops Research*. **86**: 199-209.
- Mohanty, G and Mohanty, S. K. (2015). Physical strain of workers with manual weeder. *Journal of Agricultural Technology*. **2(1-2)**: 38-43
- Mohanty, S. K. (2016). Occupation health complaints of female agricultural workers in rice cultivation system. *International Journal of Innovative Science, Engineering & Technol.* **3(2)**:495-502.
- Mukhopadhyay, S. K. (1992). Emerging problem and advances in weed management. Presidential Address at Agricultural Section. Indian Science Congress at Baroda.
- Nag, P. K. and Dutt, P. (1980). Circulo respiratory efficiency in some agricultural work. *Applied Ergonomics*. **11(2)**: 81-84
- Nag, P. K. and Dutta, A.(1979). Effective of some simple agricultural weeders with reference to physiological response. *Journal of Human Ergonomics*. **8(1)**:13-21.
- Naidu, V. S. G. R. (2012). Hand book on weed identification. Directorate of weed Science Research, Jabalpur, India, 354.
- Naik, R. K., Jha, S. K., Sarkar, S., and Ghorai, A. K. (2018). Performance evaluation of manualoperated single wheel weeder for jute crop. *International Journal of Agricultural Engineering*. **11(1)**: 49-53.
- Natrajan, M. (1987). Low cost and low risk improved agronomic practices to increase yield in field food crops. Improving food crop production on small farms in Africa. Food and Agricultural Organization, Rome, Italy, 367-372.
- Nkakini, S.O. and Husseni, A. (2014). Development and evaluation of wheel long-handle weeder. *The West Indian Journal of Engineering*, **37**:37-44.

- Rainbird, G.O. and Neil, D. (1995). Occupational disorders affecting agricultural workers in tropical developing countries. *Applied Ergonomics*, **26**: 187–193.
- Rangasamy, K., Balasubramaniam, M. and Swaminathan, K.R. (1993). Evaluation of power weeder performance. *Agricultural Mechanization in Asia, African and Latin America*. **24(4)**: 16-18.
- Rao, A. N. and Chauhan, B. S. (2015). Weeds and weed management in India – A review. *Weed-Science in the Asian-Pacific Region*. pp. 1-32.
- Sam, B. (2014). Ergonomic evaluation of paddy harvester and thresher with farm women. *International Journal of Science and Research*. **3(11)**: 1644-1648
- Sam, B., and Regeena, S. (2015). Development and ergonomic evaluation of long handle weeders for uplands. *International Journal of Research in Engineering and Social Sciences*. **5(6)**: 1-13.
- Sen, R. N. (1969). Tentative classification of strain in different types of jobs according to the physiological responses of young Indian workers in comfortable climates-ICMR report, Indian council of Medical Research. New Delhi.
- Sharma, B., Singh, S. R. K., Gupta, S., Shrivastava, M. K., and Verma, S. (2016). Improving efficiency and reduction in drudgery of farm women in weeding activity by twin wheel hoe. *Indian Research Journal of Extension Education*. **15(1)**: 76-80.
- Singh G. (2002). Design of hand weeder part-Proceeding of the first workshop on design methodology of agricultural machinery CIAE, Bhopal. pp.29-42
- Singh, H. (2004). Ergonomics studied on force exertion in operating wheel hand hoe summer school on advance in intercultural and plant protection equipment, Department of Farm Power and Machinery, PAU, Ludhiana, pp. 114-115.
- Singh, R. S., Singh, K., and Dubey, A. (2014). Custom hiring business model and decision support system of agricultural machinery. *Agricultural Engineering Today*. **38(4)**, 31-36.

- Singh, S. P. (2012). Physiological workload of farm women while evaluating sickles for paddy harvesting. *Agricultural Engineering International: CIGR Journal*. **14(1)**: 82-88
- Swarna, P., Laxmi, R. P., Reddy, P., and Kumar, P. G. (2018). Ergonomic study on drudgery reduction using three tyne wheel hoe for weeding activity. *Journal of Krsi Vigyan*. **6(2)**: 95-100.
- Tajuddin, A. (2006). Design, development and testing of engine operated weeder. *Agricultural Engineering Today*. **30(5-6)**: 25–29.
- Teronpi, A. (2017). Development and performance evaluation of push type weeder for women. Unpublished M.Tech. Thesis. CAET, Junagadh Agricultural University, Junagadh, Gujarat. <http://krishikosh.egranth.ac.in/handle/1/5810034408>, Accessed on 5th May 2021.
- Tripathi, S. P., Chundawat, G. S., Somvanshi, S. P. S., and Shrivastava, D. C. (2016). Drudgery reduction of farm women through twin wheel hoe for weeding in soyabean crop. *Research in Environmental and Life Science*. **9(7)**: 819-821.
- Upedar, K., Dash, R. C., Behara, D and Goel, A. K. (2018). Ergonomical evaluation of power weeder in wet land paddy condition. *International Journal of Current Microbiology and applied sciences*. **7(11)**: 855-862
- Verma, S., Gupta, S and Pachauri, C. P. (2013). An ergonomic study on evaluation of single wheel hoe in reducing drudgery. *Agriculture Update*. **8(4)**: 665-669.
- Vivek, D. R., Deshmukh, B. D. and Dinesh, D. (2013). Review paper on various aspects of weeders for economical cultivation. *International Journal of Modern Engineering Research*. **3(5)**: 3296-3299.
- Yadav, R. and Pund, S. (2007). Development and ergonomic evaluation of manual weeder. *Agricultural Engineering International: The CIGR Journal*.
- Yadav, R., Jakasania, R. G. and Vadher, A. L. (2018). Segmental proportions based on anthropometry of female agricultural workers, India. *Ergonomics International Journal*. **2(7)**

APPENDIX – A

SOIL MOISTURE CONTENT

Sr. No.	Wt. of wet soil sample + box	Wt. of dry soil sample + box	Wt. of empty box	Moisture content (%)	Average
1.	2589	2355.5	936.5	16.45	17.15%
2.	2595	2350.25	936.5	17.31	
3.	2589	2340.42	936.5	17.70	

Soil moisture content in groundnut field

$$(1) \text{ Moisture content (\% db)} = \frac{(\text{wt.of wet soil+box}) - (\text{wt.of dry soil+box})}{(\text{wt.of dry soil+box}) - (\text{wt.of empty box})}$$

$$= \frac{2589 - 2355.5}{2355.5 - 936.5}$$

$$= \frac{233.5}{1419} \times 100$$

$$= 16.45\%$$

$$(2) = \frac{2595 - 2350.25}{2350.5 - 936.5} \times 100$$

$$= \frac{244.75}{1414} \times 100$$

$$= 17.31\%$$

$$(3) = \frac{2589 - 2340.42}{2340.42 - 936.5} \times 100$$

$$= \frac{248.58}{1403.92} \times 100$$

$$= 17.70\%$$

So, the moisture content of soil was found to be 17.15%

Sr. No.	Wt. of wet soil sample + box	Wt. of dry soil sample + box	Wt. of empty box	Moisture content (%)	Average
1.	2599	2330.67	936.5	19.24	20%
2.	2594	2315.87	936.5	20.16	
3.	2594	231.21	936.5	20.57	

Soil moisture content in blackgram field

$$(1) \text{ Moisture content (\% db)} = \frac{(\text{wt. of wet soil+box}) - (\text{wt. of dry soil+box})}{(\text{wt of dry soil+bbox}) - (\text{wt. of empty box})}$$

$$= \frac{2599 - 2330.67}{2330.67 - 936.5}$$

$$= \frac{268.33}{1394.17} \times 100$$

$$= 19.24 \%$$

$$(2) = \frac{2594 - 2315.87}{2315.87 - 936.5} \times 100$$

$$= \frac{278.13}{1379.37} \times 100$$

$$= 20.16 \%$$

$$(3) = \frac{2594 - 2311.21}{2311.21 - 936.5} \times 100$$

$$= \frac{282.79}{1374.71} \times 100$$

$$= 20.57 \%$$

So, the moisture content of soil was found to be 20 %

APPENDIX – B

SOIL BULK DENSITY

Soil bulk density in groundnut field

Weight of soil sample

Sample 1 = 1652.5gm

Sample 2 = 1658.5gm

Sample 3 = 1652.5gm

$$\begin{aligned}\text{So, Weight of the soil sample} &= \frac{1652.5+1658.5+1652.5}{3} \\ &= 1654.5 \text{ gm}\end{aligned}$$

Volume of core sampler

Diameter of core sampler, d = 10 cm

Radius r = 5 cm

Height of core sampler = 12.8 cm

$$\begin{aligned}\text{So, Volume of core sampler} &= \pi \times r^2 \times h \\ &= 3.14 \times 5^2 \times 12.8 \\ &= 1004.8 \text{ cm}^3\end{aligned}$$

$$\begin{aligned}\text{Bulk density of soil sample} &= \frac{1654.5}{1004.8} \\ &= 1.64 \text{ gm/cm}^3\end{aligned}$$

Soil bulk density in blackgram field

Weight of soil sample

Sample 1 = 1662.5gm

Sample 2 = 1657.5gm

Sample 3 = 1657.5gm

$$\begin{aligned}\text{So, Weight of the soil sample} &= \frac{1662.5+1657.5+1657.5}{3} \\ &= 1659.16 \text{ gm}\end{aligned}$$

Volume of core sampler

Diameter of core sampler, $d = 10$ cm

Radius $r = 5$ cm

Height of core sampler = 12.8 cm

$$\begin{aligned}\text{So, Volume of core sampler} &= \pi \times r^2 \times h \\ &= 3.14 \times 5^2 \times 12.8 \\ &= 1004.8 \text{ cm}^3\end{aligned}$$

$$\begin{aligned}\text{Bulk density of soil sample} &= \frac{1659.16}{1004.8} \\ &= 1.65 \text{ gm/cm}^3\end{aligned}$$

APPENDIX – C

COST CALCULATION

Following assumption was made for cost estimation of finger weeder:

1. Initial cost of weeder = 7000₹
2. Expected life of weeder = 8 years
3. Annual working hour(H) = 600h/year, when working hour is 8 h /day
4. Salvage value(S) = 10% of initial cost
5. Rate of interest = 10% per annum
6. Labour required = 01
7. Repair and maintenance = 2.5% of initial cost
8. Housing, insurance and tax cost = 2% of initial cost

A. Fixed cost

$$\begin{aligned}
 \text{i. Depreciation (D) /h} &= \frac{C-S}{L \times H} \\
 &= \frac{7000-700}{8 \times 600} \\
 &= 1.3125 \text{ ₹/ h}
 \end{aligned}$$

Where,

D = Depreciation ₹/ h

C = Capital cost / new cost ₹

S = Salvage value 10 % of initial cost

L = Life of the implement year

H = Annual use of implement (h)

$$\begin{aligned}
 \text{ii. Interest (I) / h} &= \frac{(C+S) \times r}{2 \times H} \\
 &= \frac{7000+700}{2} \times \frac{0.10}{600} \\
 &= 0.641 \text{ ₹/h}
 \end{aligned}$$

Where,

r = rate of interest 10% per annum

H = Annual use of implement (h)

$$\text{iii. Housing, insurance and tax cost} = \frac{2\% \text{ of initial cost}}{\text{working hours}(H)}$$

$$= \frac{0.02 \times 7000}{600}$$

$$= 0.233 \text{ ₹/h}$$

$$\text{Total fixed cost} = 1.3125 + 0.641 + 0.233$$

$$= 2.1865 \text{ ₹/h}$$

B. Variable cost

i. Repair and maintenance cost = $\frac{2.5\% \text{ of initial cost}}{\text{working hours (H)}}$

$$= \frac{0.025 \times 7000}{600}$$

$$= 0.29 \text{ ₹/h}$$

ii. Wages of one operator per day of 8 h = 300 ₹

$$\text{Wages of one operator per hour} = 37.5 \text{ ₹/h}$$

$$\text{Total variable cost} = 0.29 + 37.5$$

$$= 37.79 \text{ ₹/h}$$

Total cost of operation = Total fixed cost + Total variable cost

$$= 2.1865 + 37.79$$

$$= 39.464 \text{ ₹/h}$$

Effective field capacity (avg.) = 0.0356 ha/h and 0.0344 ha/h

Therefore, **cost of operation for groundnut field** = $\frac{39.46}{0.0356}$

$$= 1109.11 \text{ ₹/ha}$$

Therefore, **cost of operation for blackgram field** = $\frac{39.46}{0.0344}$

$$= 1147.80 \text{ ₹/ha}$$

APPENDIX – D

COST OF HAND WEEDING

CALCULATION OF COST OF OPERATION FOR HAND WEEDING

Wages of one labour per day of 8 h = 300 ₹

Wages of one labour per hour = 37.5 ₹/h

Total number of labour required for operation = 6

Effective field capacity = 0.056 and 0.070 ha/h (for groundnut and blackgram field)

Therefore,

Cost of operation for hand weeding in groundnut field

$$\begin{aligned} &= \frac{37.5 \times 4}{4 \times 0.0140} \\ &= 2678.57 \text{ ₹/ha} \end{aligned}$$

Cost of operation for hand weeding in blackgram field

$$\begin{aligned} &= \frac{37.5 \times 6}{4 \times 0.0175} \\ &= 2142.85 \text{ ₹/ha} \end{aligned}$$

APPENDIX – E

CALCULATION OF BMI INDEX

OPERATOR	WEIGHT (kg)	HEIGHT (m)	BMI (kg/m ²)
O ₁	50	1.676	17.80
O ₂	72	1.778	22.77
O ₃	65	1.727	21.79

$$\begin{aligned}\text{For operator O}_1, \text{ BMI} &= \frac{\text{Weight of operator}}{(\text{Height of operator})^2} \\ &= \frac{50}{1.676^2} \\ &= 17.80 \text{ kg/m}^2\end{aligned}$$

$$\begin{aligned}\text{For operator O}_2 &= \frac{72}{1.778^2} \\ &= 22.77 \text{ kg/m}^2\end{aligned}$$

$$\begin{aligned}\text{For operator O}_3 &= \frac{65}{1.727^2} \\ &= 21.79 \text{ kg/m}^2\end{aligned}$$

APPENDIX – F

CALCULATION OF OPERATIONAL TIME

$$\text{Operational time (man-h/ha)} = \frac{T}{A} \times N$$

Where,

T = Total time taken for operation, h

A = Area of experimental plot, ha

N = Number of labours

1. For mechanical weeding (Groundnut field)

$$T = 0.072 \text{ h}$$

$$A = 0.00255 \text{ ha}$$

$$N = 1$$

Therefore,

$$\begin{aligned} \text{Operational time (man-h/ha)} &= \frac{0.072}{0.00255} \times 1 \\ &= 28.10 \text{ man-h/ha} \end{aligned}$$

(Operational time in blackgram field)

$$T = 0.074 \text{ h}$$

$$A = 0.00255 \text{ ha}$$

$$N = 1$$

Therefore,

$$\begin{aligned} \text{Operational time (man-h/ha)} &= \frac{0.074}{0.00255} \times 1 \\ &= 29.08 \text{ man-h/ha} \end{aligned}$$

2. For hand weeding (Groundnut field)

$$T = 2.5 \text{ h}$$

$$A = 0.035 \text{ ha}$$

$$N = 4$$

Therefore,

$$\begin{aligned}\text{Operational time (man-h/ha)} &= \frac{2.5}{0.035} \times 4 \\ &= 285.71 \text{ man-h/ha}\end{aligned}$$

(Operational time in blackgram field)

$$T = 2 \text{ h}$$

$$A = 0.035 \text{ ha}$$

$$N = 4$$

Therefore,

$$\begin{aligned}\text{Operational time (man-h/ha)} &= \frac{2}{0.035} \times 4 \\ &= 228 \text{ man-h/ha}\end{aligned}$$

APPENDIX- G

CALCULATION OF ENERGY CONSUMPTION

$$\text{Energy consumption (MJ/ha)} = 1.96 \times N \times O_t$$

Where,

N = Number of labours for operation

O_t = Operational time, h/ha

1. For mechanical weeding (Groundnut field)

$$N = 1$$

$$O_t = 28.1 \text{ h/ha}$$

Therefore,

$$\begin{aligned} \text{Energy consumption (MJ/ha)} &= 1.96 \times N \times O_t \\ &= 1.96 \times 1 \times 28.1 \\ &= 55.076 \text{ MJ/ha} \end{aligned}$$

(energy consumption in blackgram field)

$$N = 1$$

$$O_t = 29.80 \text{ h/ha}$$

Therefore,

$$\begin{aligned} \text{Energy consumption (MJ/ha)} &= 1.96 \times N \times O_t \\ &= 1.96 \times 1 \times 29.80 \\ &= 58.40 \text{ MJ/ha} \end{aligned}$$

2. For hand weeding (Groundnut field)

$$N = 4$$

$$O_t = 71.4 \text{ h/ha}$$

Therefore,

$$\begin{aligned} \text{Energy consumption (MJ/ha)} &= 1.96 \times N \times O_t \\ &= 1.96 \times 4 \times 71.4 \\ &= 559.99 \text{ MJ/ha} \end{aligned}$$

(energy consumption in blackgram field)

$$N = 4$$

$$O_t = 57 \text{ h/ha}$$

Therefore,

$$\begin{aligned}\text{Energy consumption (MJ/ha)} &= 1.96 \times N \times O_t \\ &= 1.96 \times 4 \times 57.14 \\ &= 446.88 \text{ MJ/ha}\end{aligned}$$

APPENDIX- H

CALCULATION OF WEED CONTROL EFFICIENCY

$$\text{Weed control efficiency (\%)} = \frac{N_1 - N_2}{N_1} \times 100$$

Where,

N_1 = number of weeds before operation

N_2 = number of weeds after operation

1. Weeding by finger weeder

Sr. No.		N_1	N_2	Weeding efficiency (%)	Mean (%)
1.	Groundnut crop	45	8	82.22	80.13
2.		52	12	76.92	
3.		48	9	81.25	
4.	Black gram crop	85	25	70.58	74.023
5.		81	22	72.83	
6.		75	16	78.66	

2. For hand weeding

$N_1 = 620$

$N_2 = 12$

Therefore,

$$\begin{aligned} \text{Weed control efficiency} &= \frac{620 - 12}{620} \times 100 \\ &= 98.06\% \end{aligned}$$